

**Silicon NPN Power Transistors**

**2SC2591 2SC2592**

**DESCRIPTION**

- With TO-220 package
- Complement to type 2SA1111/1112
- Good linearity of  $h_{FE}$
- High  $V_{CEO}$

**APPLICATIONS**

- For audio frequency, high power amplifiers application

**PINNING**

PIN	DESCRIPTION
1	Emitter
2	Collector;connected to mounting base
3	Base

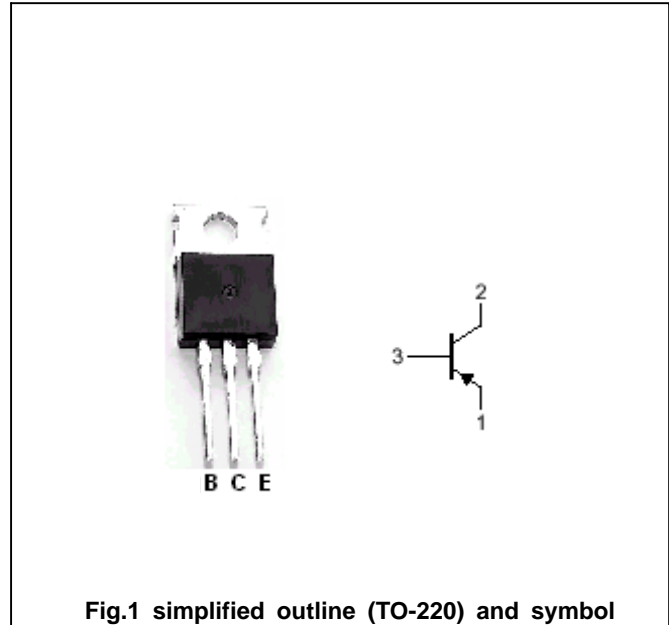

Fig.1 simplified outline (TO-220) and symbol

**Absolute maximum ratings( $T_a=25$  )**

SYMBOL	PARAMETER	CONDITIONS	VALUE	UNIT
$V_{CBO}$	Collector-base voltage	2SC2591	150	V
		2SC2592	180	
$V_{CEO}$	Collector-emitter voltage	2SC2591	150	V
		2SC2592	180	
$V_{EBO}$	Emitter-base voltage	Open collector	5	V
$I_C$	Collector current		1	A
$I_{CM}$	Collector current-peak		1.5	A
$P_C$	Collector power dissipation	$T_C=25$	20	W
$T_j$	Junction temperature		150	
$T_{stg}$	Storage temperature		-55~150	

## Silicon NPN Power Transistors

## 2SC2591 2SC2592

## CHARACTERISTICS

T<sub>j</sub>=25 unless otherwise specified

SYMBOL	PARAMETER	CONDITIONS	MIN	TYP.	MAX	UNIT
V <sub>CEO</sub>	Base-emitter breakdown voltage	2SC2591	150			V
		2SC2592	180			
V <sub>EBO</sub>	Emitter-base breakdown voltage	I <sub>E</sub> =10 μA, I <sub>C</sub> =0	5			V
V <sub>CEsat</sub>	Collector-emitter saturation voltage	I <sub>C</sub> =0.5A; I <sub>B</sub> =50mA		0.5	2.0	V
V <sub>BEsat</sub>	Base-emitter saturation voltage	I <sub>C</sub> =0.5A; I <sub>B</sub> =50mA		1.0	2.0	V
I <sub>CBO</sub>	Collector cut-off current	V <sub>CB</sub> =120V; I <sub>E</sub> =0			1	μA
I <sub>EBO</sub>	Emitter cut-off current	V <sub>EB</sub> =4V; I <sub>C</sub> =0			1	μA
h <sub>FE-1</sub>	DC current gain	I <sub>C</sub> =150mA; V <sub>CE</sub> =10V	90		330	
h <sub>FE-2</sub>	DC current gain	I <sub>C</sub> =500mA; V <sub>CE</sub> =5V	50			
C <sub>OB</sub>	Output capacitance	I <sub>E</sub> =0; V <sub>CB</sub> =10V; f=1MHz		20		pF
f <sub>T</sub>	Transition frequency	I <sub>C</sub> =50mA; V <sub>CE</sub> =10V		200		MHz

◆ h<sub>FE-1</sub> Classifications

Q	R	S
90-155	130-220	185-330

Silicon NPN Power Transistors

2SC2591 2SC2592

PACKAGE OUTLINE

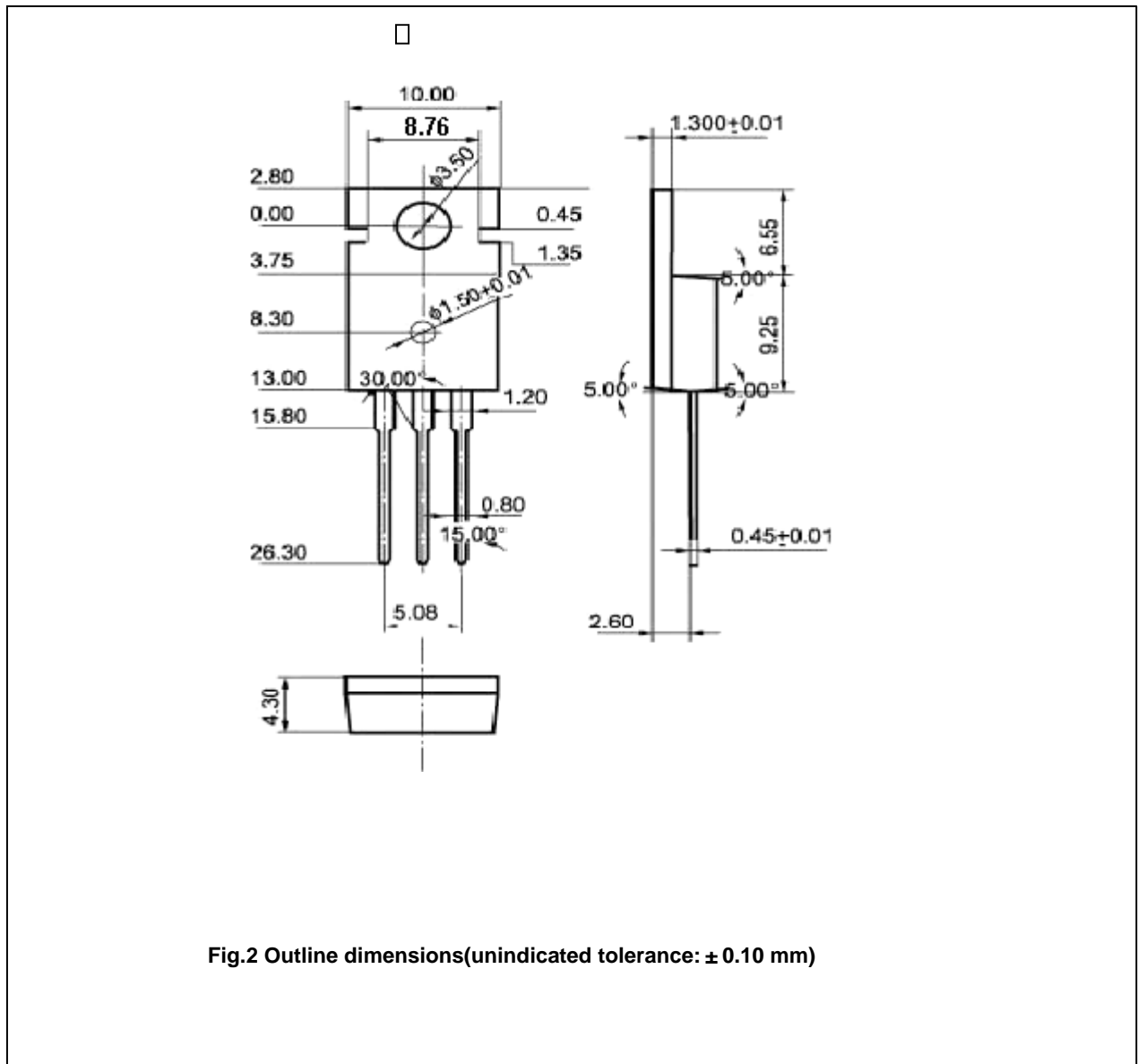

Fig.2 Outline dimensions(unindicated tolerance: ± 0.10 mm)