

TITLE
TRANSFORMER, ADSL
CUSTOMER PREMISES

SCHOTT
 CORPORATION
 1000 PARKERS LAKE ROAD
 WAYZATA, MN 55391

PART NUMBER
31442
 REV 2 PAGE 1 END
 12-16-98

SPECIFICATIONS

TEMPERATURE CLASS 105°C
 Designed to meet UL1950/IEC-950 requirements.

1. INDUCTANCE: @ 0.1Vrms, 10 KHz
 1-3-2-4 = 366.3 TO 447.7 μH
2. LEAKAGE INDUCTANCE: @ 0.1Vrms, 100 KHz
 1-3-2-4 W/ 8-6-7-5 SHORTED = 10 μH MAX
3. IWC: @ 0.1Vrms, 100 KHz,
 1-3-2-4 TO 8-6-7-5 = 25 pF MAX
4. TURNS RATIO: 1-3 : 2-4 : 8-6 : 7-5 = 1 : 1 : 1 : 1 ± 2%
5. DC RESISTANCE: OHMS MAX
 1-3, 2-4 = 0.5
 8-6, 7-5 = 0.5
6. LONGITUDINAL BALANCE:
 @ 100 KHz , 100 OHM = -60 dB MIN
7. DIELECTRIC STRENGTH: 1500Vrms, 1 minute
 (1800 Vrms 1 second Schott production test)
 1-2-3-4 TO 5-6-7-8
 ALL WINDINGS TO CORE
8. HARMONIC DISTORTION:
 @ 100 KHz, 15 Vp-p, 100 OHM = -80 dB MIN

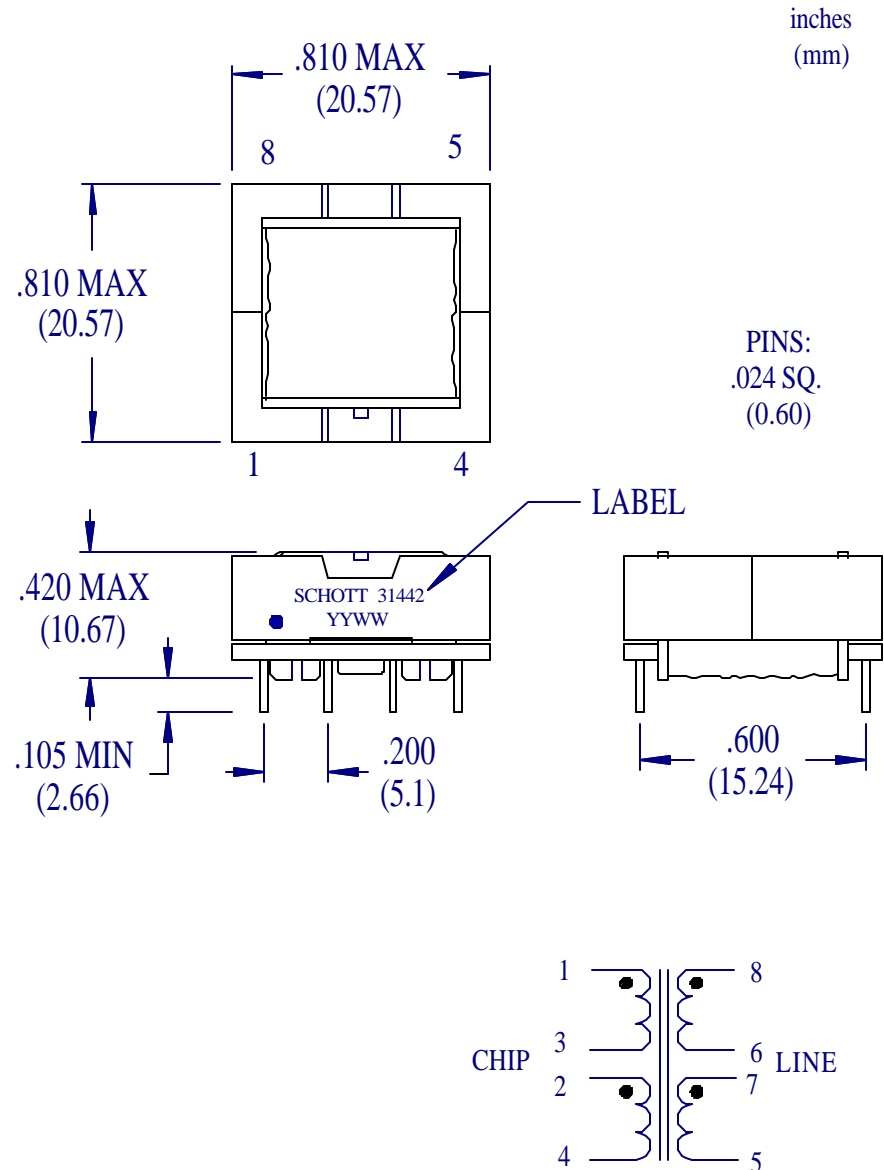

inches
(mm)

PINS:
 .024 SQ.
 (0.60)

TOLERANCES	2 PLACE	3 PLACE	ANGLE
UNLESS OTHERWISE NOTED	+ .02	+ .005	+ °