

GENERAL DESCRIPTION

The CM1117 series of adjustable and fixed voltage regulators are designed to provide 1A for applications requiring high efficiency. All internal circuitry is designed to operate down to 1V input to output differential and the dropout voltage is fully specified as a function of load current.

The CM1117 offers current limiting and thermal protection. The on chip trimming adjusts the reference voltage accuracy to 1%.

FEATURES

- ◆ Three Terminal Adjustable or Fixed Voltages: 1.8V, 2.5V, 3.3V, and adjustable.
- ◆ Output Current of 1A
- ◆ Low dropout voltage: 1V Typ.
- ◆ Line Regulation: 0.2% Max
- ◆ Load Regulation: 0.4% Max
- ◆ Fast Transient Response
- ◆ Thermal Protection
- ◆ SOT-223 and TO-252 package available

APPLICATIONS

- ◆ High Efficiency Linear Regulators
- ◆ Post Regulators for Switching Supplies
- ◆ Battery Chargers
- ◆ Active SCSI Terminators
- ◆ Post Regulator for Switching DC/DC Converter
- ◆ Battery Powered Instrumentation

PIN CONFIGURATION



ORDERING INFORMATION

Package Type		Operating Temperature Range (T _A)	Output Voltage
TO-252	SOT-223		
CM1117DCN252	CM1117DCM223	0°C ~ +125°C	1.8V
CM1117KCN252	CM1117KCM223	0°C ~ +125°C	2.5V
CM1117SCN252	CM1117SCM223	0°C ~ +125°C	3.3V
CM1117CN252	CM1117CM223	0°C ~ +125°C	ADJ.
CM1117GDCN252*	CM1117GDGM223*	0°C ~ +125°C	1.8V
CM1117GKCN252*	CM1117GKGM223*	0°C ~ +125°C	2.5V
CM1117GSCN252*	CM1117GSGM223*	0°C ~ +125°C	3.3V
CM1117GCN252*	CM1117GCM223*	0°C ~ +125°C	ADJ.

*Note: G : Suffix for Pb Free Product

ABSOLUTE MAXIMUM RATINGS

Input Voltage +18V
 Operating Junction Temperature Range, T_J 0°C to +125°C
 Storage Temperature -65°C to +150°C
 Lead Temperature (10 sec.) 260°C

THERMAL INFORMATION

Parameter		Maximum	Unit
Thermal Resistance (θ_{jc})	SOT-223	15	°C/W
	TO-252	50	
Thermal Resistance (θ_{ja})	SOT-223	136	°C/W
	TO-252	80	
Internal Power Dissipation (P_D) ($\Delta T = 100^\circ\text{C}$, No Heatsink)	SOT-223	900	mW
	TO-252	1500	
Maximum Junction Temperature		150	°C
Maximum Lead Temperature (10 Sec)		300	°C

BLOCK DIAGRAM

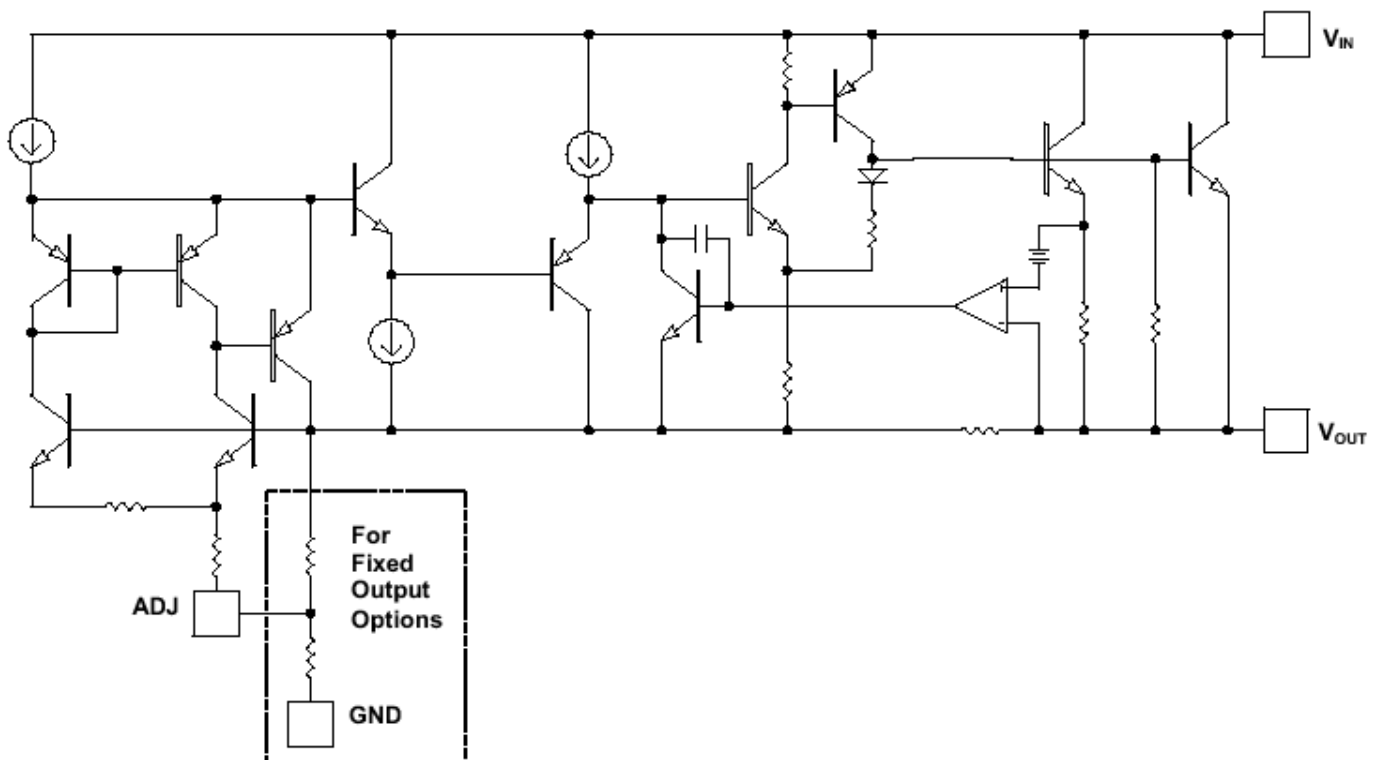

ELECTRICAL CHARACTERISTICS

Electrical Characteristics at $I_{OUT} = 10mA$, and $T_J = +25^\circ C$; unless otherwise noted

Symbol	Parameter	Conditions	Min (Note 2)	Typ (Note 1)	Max (Note 2)	Units
V_{REF}	Reference Voltage	CM1117-ADJ $I_{OUT}=10mA$, $V_{IN}-V_{OUT}=2V$, $T_J=25^\circ C$ $10mA \leq I_{OUT} \leq 1A$, $1.4V \leq V_{IN}-V_{OUT} \leq 10V$	1.238	1.250	1.262	V
V_{OUT}	Output Voltage	CM1117 -1.8 $I_{OUT}=10mA$, $V_{IN}=3.8V$, $T_J=25^\circ C$ $0 \leq I_{OUT} \leq 1A$, $3.2V \leq V_{IN}-V_{OUT} \leq 10V$	1.764	1.8	1.836	V
		CM1117 -2.5 $I_{OUT}=10mA$, $V_{IN}=4.5V$, $T_J=25^\circ C$ $0 \leq I_{OUT} \leq 1A$, $3.9V \leq V_{IN}-V_{OUT} \leq 10V$	2.45	2.500	2.55	V
		CM1117 -3.3 $I_{OUT}=10mA$, $V_{IN}=5V$, $T_J=25^\circ C$ $0 \leq I_{OUT} \leq 1A$, $4.75V \leq V_{IN}-V_{OUT} \leq 10V$	3.234	3.300	3.366	V
ΔV_{OUT}	Line Regulation (Note 3)	CM1117 -ADJ $I_{OUT}=10mA$, $1.5V \leq V_{IN}-V_{OUT} \leq 13.75V$		0.035	0.2	%
		CM1117 -1.8 $I_{OUT}=0mA$, $3.2V \leq V_{IN} \leq 10V$		1	6	mV
		CM1117 -2.5 $I_{OUT}=0mA$, $3.9V \leq V_{IN} \leq 10V$		1	6	mV
		CM1117 -3.3 $I_{OUT}=0mA$, $4.75V \leq V_{IN} \leq 10V$		1	6	mV
ΔV_{OUT}	Load Regulation (Note 3)	CM1117 -ADJ $V_{IN}-V_{OUT}=3V$, $10mA \leq I_{OUT} \leq 1A$		0.2	0.4	%
		CM1117 -1.8 $V_{IN}=3.2V$, $0 \leq I_{OUT} \leq 1A$		1	10	mV
		CM1117 -2.5 $V_{IN}=3.9V$, $0 \leq I_{OUT} \leq 1A$		1	10	mV
		CM1117 -3.3 $V_{IN}=4.75V$, $0 \leq I_{OUT} \leq 1A$		1	10	mV
$V_{IN}-V_{OUT}$	Dropout Voltage (Note 4)	$I_{OUT} = 100mA$		1.10	1.20	V
		$I_{OUT} = 500mA$		1.15	1.25	V
		$I_{OUT} = 1A$ (TO-252)		1.20	1.30	V
I_{LIMIT}	Current Limit	$V_{IN}-V_{OUT}=5V$, $T_J=25^\circ C$	1000	1200	1500	mA
	Minimum Load Current (Note 5)	CM1117 -ADJ $V_{IN}=15V$		1.7	5	mA
	Quiescent Current	CM1117 -1.8, $V_{IN} \leq 15V$		5	10	mA
CM1117 -2.5, $V_{IN} \leq 15V$			5	10	mA	
CM1117 -3.3, $V_{IN} \leq 15V$			5	10	mA	
	Thermal Regulation	$T_A=25^\circ C$, 30ms Pulse		0.01	0.1	%/W
	Ripple Regulation	$f_{RIPPLE}=120Hz$, $V_{IN}-V_{OUT}=3V$ $V_{RIPPLE}=1V_{PP}$	60	75		dB
	Adjust Pin Current			60	120	μA
	Adjust Pin Current Change	$10mA \leq I_{OUT} \leq 1A$ $1.4V \leq V_{IN}-V_{OUT} \leq 10V$		0.2	5	μA
	Temperature Stability			0.5		%
	Long Term Stability	$T_A=125^\circ C$, 1000Hrs		0.3		%
	RMS Output Noise	(% of V_{OUT}), $10Hz \leq f \leq 10kHz$		0.003		%
	Thermal Resistance Junction-to-Case	3-Lead SOT-223		15.0		$^\circ C/W$
		3-Lead TO-252		3.0		$^\circ C/W$
					10	
	Thermal Resistance Junction-to-Ambient (No heat sink; No air flow)	3-Lead SOT-223		136		$^\circ C/W$
		3-Lead TO-252 (Note 6)		79		$^\circ C/W$
					92	

Note 1: Typical Values represent the most likely parametric norm.

Note 2: All limits are guaranteed by testing or statistical analysis.

Note 3: Load and line regulation are measured at constant junction room temperature.

Note 4: The dropout voltage is the input/output differential at which the circuit ceases to regulate against further reduction in input voltage. It is measured when the output voltage has dropped 100mV from the nominal value obtained at $V_{IN} = V_{OUT} + 1.5V$.

Note 5: The minimum output current required to maintain regulation.

Note 6: Minimum pad size of $0.038in^2$

Application Hints

Like any linear voltage regulator, CM1117 requires external capacitors to ensure stability. The external capacitors must be carefully selected to ensure performance.

Input Capacitor

An input capacitor of at least $10\mu F$ is required. Ceramic or Tantalum can be used. The value can be increase without upper limit.

Output Capacitor

An output capacitor is required for stability. It must be placed no more than 1 cm away from the V_{OUT} pin, and connected directly between V_{OUT} and GND pins. The minimum value is $22\mu F$ but may be increase without limit.

Thermal Considerations

It is important that the thermal limit of the package is not exceeded. The CM1117 has built-in thermal protection. When the thermal limit is exceeded, the IC will enter protection, and V_{OUT} will be pulled to ground. The power dissipation for a given application can be calculated as following:

The power dissipation (P_D) is

$$P_D = I_{OUT} * [V_{IN} - V_{OUT}]$$

APPLICATION CIRCUIT

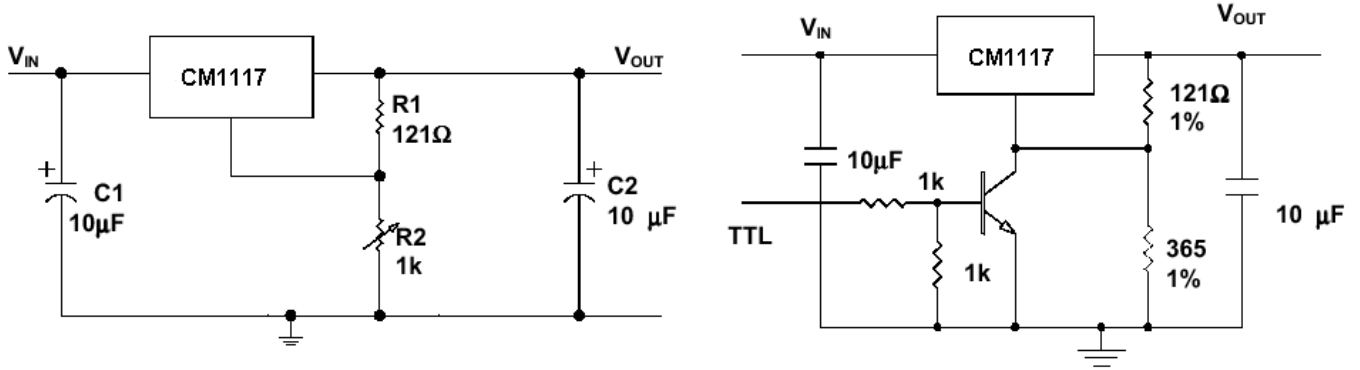

Adjustable Regulator
 $V_{OUT} = 1.25V (1 + R2/R1)$

5V Regulator with Shutdown

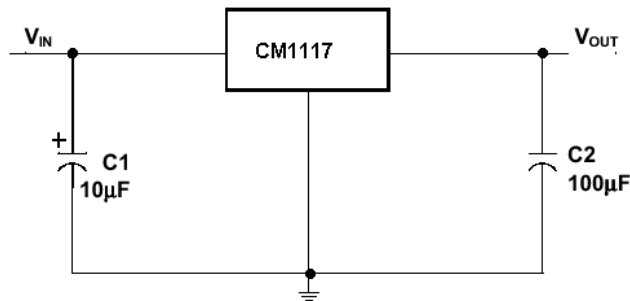

Fixed Voltage Regulator

PACKAGE DIMENSION

SOT-223 (M223)

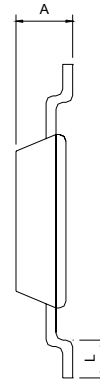
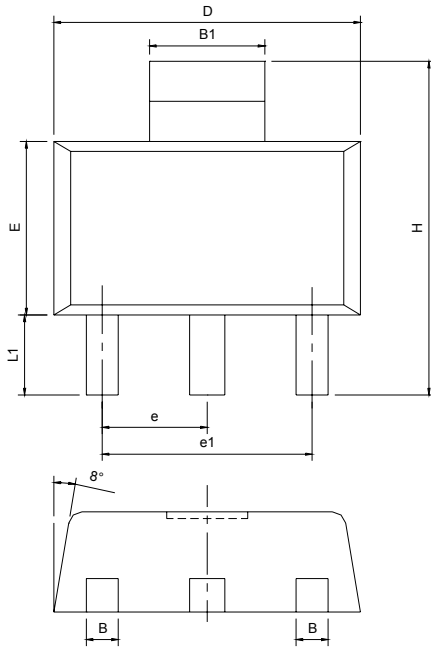

SYMBOLS	DIMENSIONS IN MILLIMETERS			DIMENSIONS IN INCHES		
	MIN	NOM	MAX	MIN	NOM	MAX
A	1.50	---	1.80	0.0591	---	0.0709
B	0.80	---	0.838	0.0236	---	0.033
B1	2.895	---	3.15	0.114	---	0.124
D	6.299	---	6.708	0.248	---	0.264
E	3.30	---	3.708	0.1299	---	0.146
e	---	2.30BSC	---	---	0.0906	---
e1	---	4.00BSC	---	---	0.1575	---
H	6.70	---	7.30	0.2638	---	0.2874
L	---	0.91MIN	---	---	0.0358MIN	---
L1	---	2.08MAX	---	---	0.0799MAX	---
θ	---	---	13°	---	---	13°

TO-252 (N252)

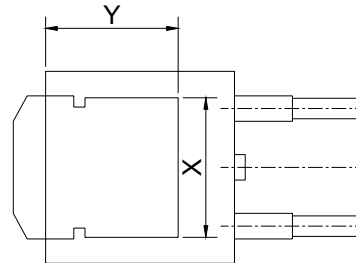
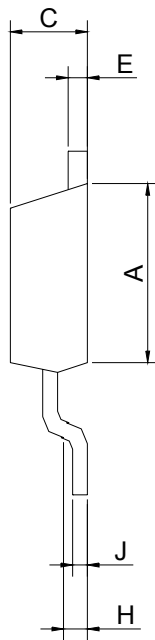
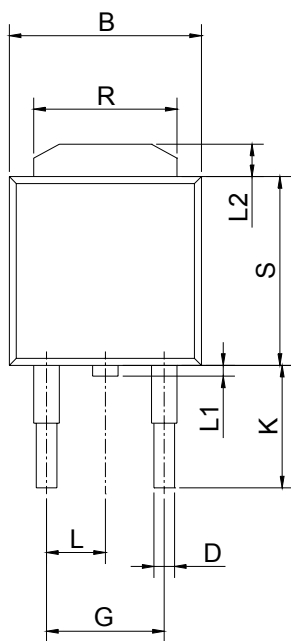

SYMBOLS	DIMENSIONS IN MILLIMETERS			DIMENSIONS IN INCHES		
	MIN	NOM	MAX	MIN	NOM	MAX
A	5.97	---	6.35	0.235	---	0.250
B	6.35	---	6.73	0.250	---	0.265
C	2.19	---	2.38	0.086	---	0.094
D	0.69	---	0.88	0.027	---	0.035
E	0.46	---	0.58	0.018	---	0.023
d	4.58BSC			0.180BSC		
H	0.87	---	1.01	0.034	---	0.040
J	0.46	---	0.58	0.018	---	0.023
K	2.60	---	2.89	0.102	---	0.114
L	2.29BSC			0.090BSC		
R	4.45	---	5.46	0.175	---	0.215
S	5.33	---	5.59	0.210	---	0.220
L1	0.64	---	1.02	0.025	---	0.040
L2	1.52	---	2.03	0.060	---	0.080
X	4.12	---	4.56	0.162	---	0.179
Y	5.11	---	5.72	0.201	---	0.225

IMPORTANT NOTICE

Champion Microelectronic Corporation (CMC) reserves the right to make changes to its products or to discontinue any integrated circuit product or service without notice, and advises its customers to obtain the latest version of relevant information to verify, before placing orders, that the information being relied on is current.

A few applications using integrated circuit products may involve potential risks of death, personal injury, or severe property or environmental damage. CMC integrated circuit products are not designed, intended, authorized, or warranted to be suitable for use in life-support applications, devices or systems or other critical applications. Use of CMC products in such applications is understood to be fully at the risk of the customer. In order to minimize risks associated with the customer's applications, the customer should provide adequate design and operating safeguards.

HsinChu Headquarter

5F, No. 11, Park Avenue II,
Science-Based Industrial Park,
HsinChu City, Taiwan
TEL: +886-3-567 9979
FAX: +886-3-567 9909

Sales & Marketing

7F-6, No.32, Sec. 1, Chenggong Rd., Nangang
District, Taipei City 115, Taiwan
TEL: +886-2-2788 0558
FAX: +886-2-2788 2985
