

**10 AMPERES COMPLEMENTARY
SILICON POWER TRANSISTORS 60,80 VOLTS**

FEATURES

- * ...for general purpose power amplification and switching such as output or driver stages in applications such as switching regulators, converter and power amplifiers.
- * Low Collector-Emitter Saturation Voltage
 $V_{CE(sat)} = 1.0 \text{ V (max.) @8.0A}$
- * Fast Switching Speeds
- * Complementary Pairs Simplifies Designs

MAXIMUM RATINGS AND ELECTRICAL CHARACTERISTICS

Ratings at 25°C ambient temperature unless otherwise specified.

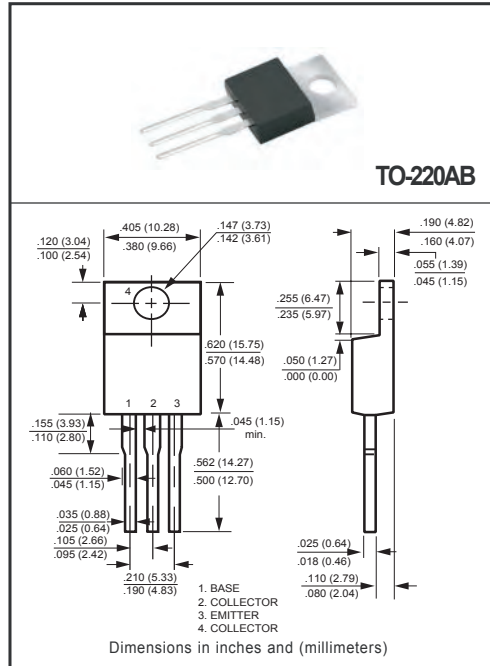

MAXIMUM RATINGS (@ TA = 25°C unless otherwise noted)

RATINGS	SYMBOL	D44H or D45H		UNITS
		8	10, 11	
Collector-Emitter voltage	V_{CEO}	60	80	V
Emitter-Base voltage	V_{EB}	5		V
Collector current-Continuous -Peak (Note 1)	I_C	10 20		A
Collector Power dissipation @ $T_C=25^\circ\text{C}$ @ $T_A=25^\circ\text{C}$	P_d	5.0 1.67		W
Thermal Resistance	$R_{\theta JA}$	75		°C/W
	$R_{\theta JC}$	2.5		
Lead Temperature for Soldering Purposes: 1/8" from case for 5 sec.	T_L	260		°C
Operating and Storage Junction Temperature Range	T_J, T_{stg}	-55 to +150		°C

Notes: 1. Pulse Width $\leq 6.0\text{mS}$, Duty Cycle $\leq 50\%$
2. "Fully RoHS Compliant", "100% Sn Plating (Pb-free)".

ELECTRICAL CHARACTERISTICS (@ TA = 25°C unless otherwise noted)

CHARACTERISTICS	SYMBOL	MIN	TYP	MAX	UNITS	
Collector cutoff current ($V_{CE} = \text{Rated } V_{CE0}, V_{BE} = 0$)	I_{CES}	-	-	10	μA	
Emitter cutoff current ($V_{EB} = 5\text{Vdc}$)	I_{EBO}	-	-	100	μA	
DC current gain ($V_{CE} = 1.0\text{V}, I_C = 2.0\text{Adc}$)	D44H10, D45H10	h_{FE}	35	-	-	-
	D44H8,11 D45H8,11		60	-	-	-
DC current gain ($V_{CE} = 1.0\text{V}, I_C = 4.0\text{Adc}$)	D44H10, D45H10	h_{FE}	20	-	-	-
	D44H8,11 D45H8,11		40	-	-	-
Collector-emitter saturation voltage ($I_C = 8.0\text{Adc}, I_B = 0.4\text{Adc}$) ($I_C = 8.0\text{Adc}, I_B = 0.8\text{Adc}$)	D44H/D45H8,11	$V_{CE(sat)}$	-	-	1.0	V
	D44H/D45H10		-	-	1.0	V
Base-emitter saturation voltage ($I_C = 8.0\text{Adc}, I_B = 0.8\text{Adc}$)	$V_{BE(sat)}$	-	-	1.5	V	
Collector Capacitance ($V_{CB} = 10\text{V}, f_{test} = 1.0\text{MHz}$)	D44H Series	C_{cb}	-	130	-	pF
	D45H Series		-	230	-	pF
Gain Bandwidth Product ($I_C = 0.5\text{Adc}, V_{CE} = 10\text{Vdc}, f = 20\text{MHz}$)	D44H Series	f_T	-	50	-	MHz
	D45H Series		-	40	-	MHz
Delay and Rise Times ($I_C = 5.0\text{Adc}, I_{B1} = 0.5\text{Adc}$)	D44H Series	$t_d + t_r$	-	300	-	nS
	D45H Series		-	135	-	nS
Storage Time ($I_C = 5.0\text{Adc}, I_{B1} = I_{B2} = 0.5\text{Adc}$)	D44H Series	t_s	-	500	-	nS
	D45H Series		-	500	-	nS
Fall Time ($I_C = 5.0\text{Adc}, I_{B1} = I_{B2} = 0.5\text{Adc}$)	D44H Series	t_f	-	140	-	nS
	D45H Series		-	100	-	nS

VD 2007-11

RATING AND CHARACTERISTICS CURVES (D44H and D45H Series)

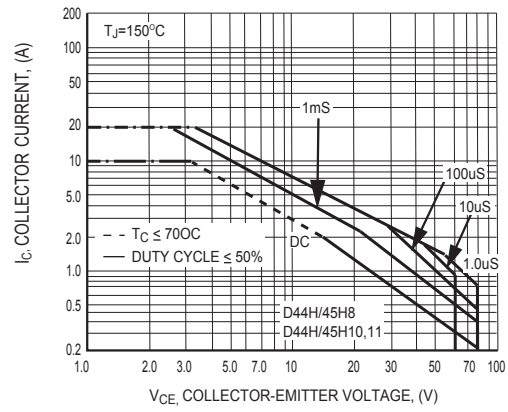

Figure Maximum Rated Forward Bias Safe Operating Area

DISCLAIMER NOTICE

Rectron Inc reserves the right to make changes without notice to any product specification herein, to make corrections, modifications, enhancements or other changes. Rectron Inc or anyone on its behalf assumes no responsibility or liability for any errors or inaccuracies. Data sheet specifications and its information contained are intended to provide a product description only. "Typical" parameters which may be included on RECTRON data sheets and/ or specifications can and do vary in different applications and actual performance may vary over time. Rectron Inc does not assume any liability arising out of the application or use of any product or circuit.

Rectron products are not designed, intended or authorized for use in medical, life-saving implant or other applications intended for life-sustaining or other related applications where a failure or malfunction of component or circuitry may directly or indirectly cause injury or threaten a life without expressed written approval of Rectron Inc. Customers using or selling Rectron components for use in such applications do so at their own risk and shall agree to fully indemnify Rectron Inc and its subsidiaries harmless against all claims, damages and expenditures.