

## Features

- Specified from 50 MHz to 20 GHz
- Usable up to 26 GHz
- Low Insertion Loss
- High Isolation
- Low Parasitic Capacitance and Inductance
- RoHS Compliant Surmount™ Package
- Rugged, Fully Monolithic
- Glass Encapsulated Construction
- Up to +38 dBm C.W. Power Handling<sup>1</sup> @ +25°C
- Silicon Nitride Passivation
- Polymer Scratch Protection

## Description

MA-COM's MASW-004103-1365 is a Surmount™ broadband monolithic SP4T switch using series and shunt connected silicon PIN diodes. This part is designed for use as a moderate signal, high performance switch in applications up to 20 GHz. This *Surface Mount* chip scale configuration is optimized for broadband performance with minimal associated parasitics usually associated with hybrid MIC designs incorporating beam lead and PIN diodes that require chip and wire assembly.

The MASW-004103-1365 is fabricated using M/A-COM's patented HMIC™ (Heterolithic Microwave Integrated Circuit) process, US Patent 5,268,310. This process allows the incorporation of silicon pedestals that form series and shunt diodes or vias by imbedding them in low loss, low dispersion glass. By using small spacing between elements, this combination of silicon and glass gives HMIC devices low loss and high isolation performance through low millimeter frequencies.

Selective backside metalization is applied producing a Surface Mount device. The topside is fully encapsulated with silicon nitride and has an additional polymer layer for scratch and impact protection. These protective coatings prevent damage to the junction and the anode airbridge during handling and assembly.

1. Power Handling Testing performed @ 2GHz

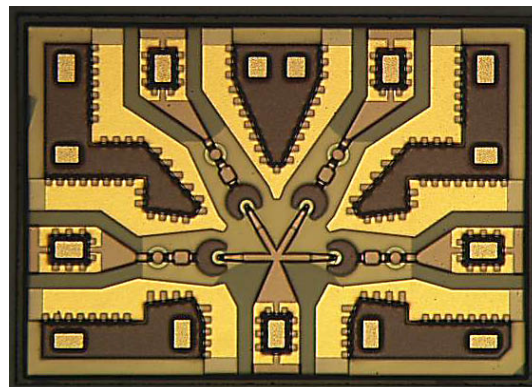

Functional Schematic

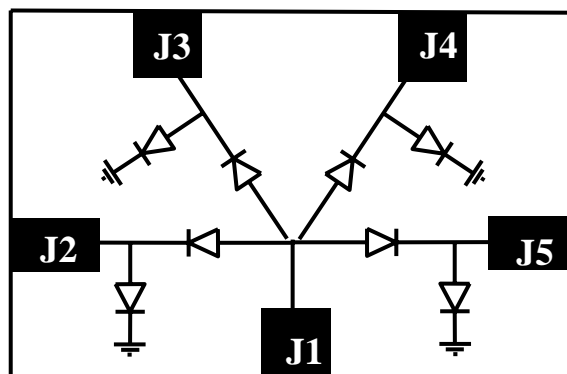

Pin Configuration <sup>2</sup>

Pin	Function
J1	RFC
J2	RF1
J3	RF2
J4	RF3
J5	RF4

2. The exposed pad centered on the chip bottom must be connected to RF and DC ground.

## Ordering Information <sup>3</sup>

Part Number	Package
MASW-004103-13650G	GEL PACK
MASW-004103-13650P	POCKET TAPE

3. Reference Application Note M513 for reel size information.

**ADVANCED:** Data Sheets contain information regarding a product M/A-COM Technology Solutions is considering for development. Performance is based on target specifications, simulated results, and/or prototype measurements. Commitment to develop is not guaranteed.  
**PRELIMINARY:** Data Sheets contain information regarding a product M/A-COM Technology Solutions has under development. Performance is based on engineering tests. Specifications are typical. Mechanical outline has been fixed. Engineering samples and/or test data may be available. Commitment to produce in volume is not guaranteed.

• **North America** Tel: 800.366.2266 / Fax: 978.366.2266  
 • **Europe** Tel: 44.1908.574.200 / Fax: 44.1908.574.300  
 • **Asia/Pacific** Tel: 81.44.844.8296 / Fax: 81.44.844.8298  
 Visit [www.macomtech.com](http://www.macomtech.com) for additional data sheets and product information.

M/A-COM Technology Solutions Inc. and its affiliates reserve the right to make changes to the product(s) or information contained herein without notice.

## HMIC™ Silicon PIN Diode SP4T Switch 50 MHz - 20 GHz

Preliminary - Rev. V2P

**Electrical Specifications:  $T_A = 25^\circ\text{C}$ ,  $P_{IN} = 0 \text{ dBm}$ ,  $Z_0 = 50 \Omega$ , 20mA/-15V**

Parameter	Conditions	Units	Min.	Typ.	Max.
Insertion Loss	6 GHz	dB	—	0.5	—
	13 GHz		—	0.8	—
	20 GHz		—	1.2	—
Isolation	6 GHz	dB	—	56	—
	13 GHz		—	41	—
	20 GHz		—	33	—
Input Return Loss	6 GHz	dB	—	22	—
	13 GHz		—	18	—
	20 GHz		—	16	—
Output to Output Isolation	6 GHz	dB	—	53.5	—
	13 GHz		—	41.5	—
	20 GHz		—	31.5	—
Switching Speed <sup>4</sup>	—	ns	—	20	—
Voltage Rating <sup>5</sup>	—	V	—	—	80
Input 0.1dB Compression Point	2 GHz	dB	—	36	—

4. Typical Switching Speed measured from 10% to 90 % of detected RF signal driven by TTL compatible drivers.

5. Maximum reverse leakage current in either the shunt or series PIN diodes shall be 0.5 uA maximum @ -80 volts.

### Functional Schematic

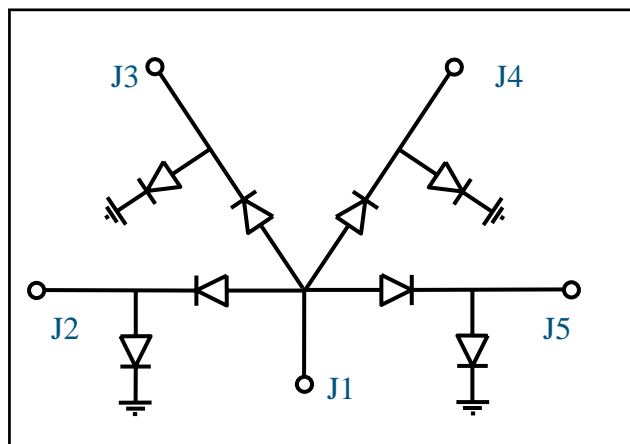

### Absolute Maximum Ratings<sup>6,7</sup>

Parameter	Absolute Maximum
Operating Temperature	-65 °C to +125 °C
Storage Temperature	-65 °C to +150 °C
Junction Temperature	+175 °C
Applied Reverse Voltage	-80 V
RF CW Incident Power	38dBm CW @ 2GHz, 25°C 33dBm CW @ 20GHz, 25°C
Bias Current +25°C	± 50 mA

**Max Operating Conditions for combination RF Pwr, DC Bias, & Temp: 33dBm CW @ 20mA per Diode @ 85°C @ 2GHz**

- Exceeding any one or combination of these limits may cause permanent damage to this device.
- M/A-COM does not recommend sustained operation near

### Handling Procedures

Please observe the following precautions to avoid damage:

### Static Sensitivity

These devices are rated at Class 1A Human Body. Proper ESD control techniques should be used when handling these devices.

### Typical Performance Curves

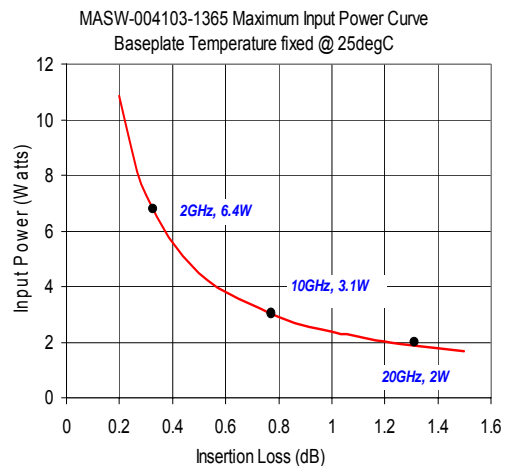
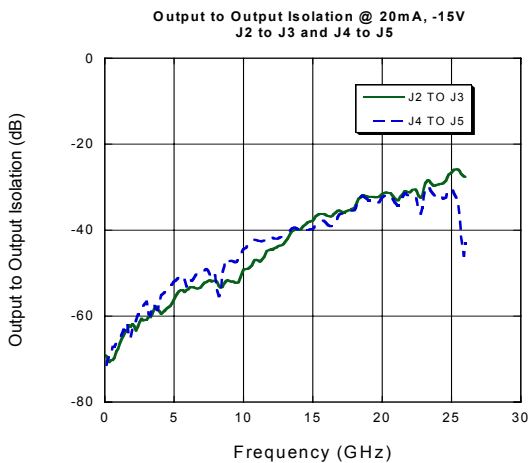
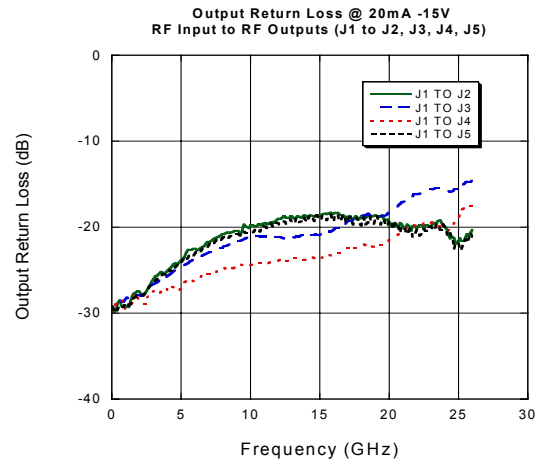
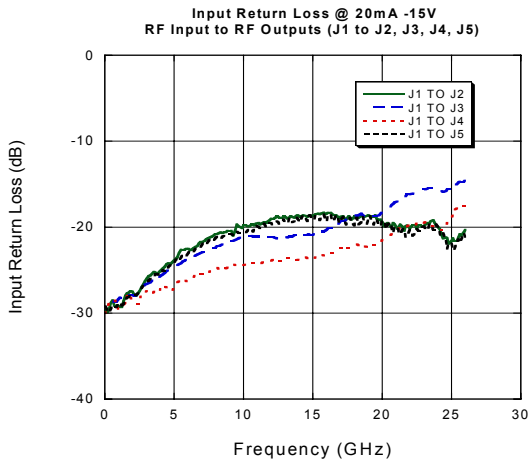
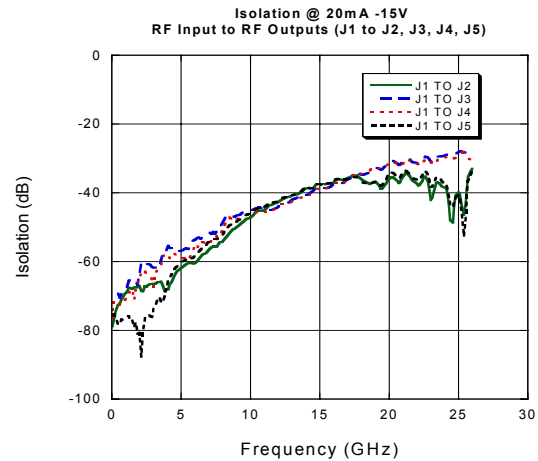
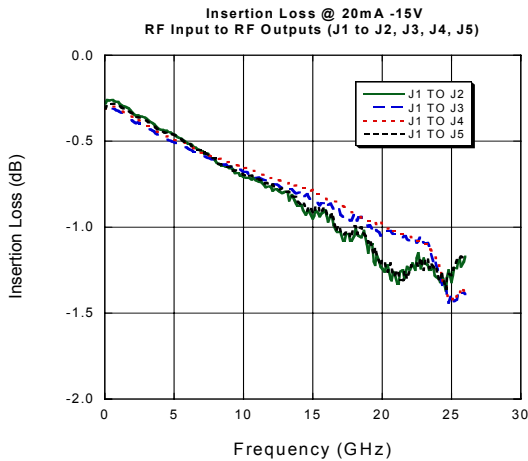

**ADVANCED:** Data Sheets contain information regarding a product M/A-COM Technology Solutions is considering for development. Performance is based on target specifications, simulated results, and/or prototype measurements. Commitment to develop is not guaranteed.  
**PRELIMINARY:** Data Sheets contain information regarding a product M/A-COM Technology Solutions has under development. Performance is based on engineering tests. Specifications are typical. Mechanical outline has been fixed. Engineering samples and/or test data may be available. Commitment to produce in volume is not guaranteed.

- **North America** Tel: 800.366.2266 / Fax: 978.366.2266
- **Europe** Tel: 44.1908.574.200 / Fax: 44.1908.574.300
- **Asia/Pacific** Tel: 81.44.844.8296 / Fax: 81.44.844.8298

Visit [www.macomtech.com](http://www.macomtech.com) for additional data sheets and product information.

M/A-COM Technology Solutions Inc. and its affiliates reserve the right to make changes to the product(s) or information contained herein without notice.

## Bias Control

Optimal operation of the MASW-004103-1365 is achieved by simultaneous application of negative DC voltage and current to the low loss switching arm and positive DC voltage and current to the remaining switching arms as shown in the applications circuit below. DC return is achieved via R2 on the RFC path.

In the low loss state, the series diode must be forward biased with current and the shunt diode reverse biased with voltage. In the isolated arm, the shunt diode is forward biased with current and the series diode is reverse biased with voltage.

## Driver Connections

Control Level (DC Currents and Voltages)				Condition of RF Output	Condition of RF Output	Condition of RF Output	Condition of RF Output
J2	J3	J4	J5	J1-J2	J1-J3	J1-J4	J1-J5
-15V at -20mA <sup>8</sup>	+20mA	+20mA	+20mA	Low Loss	Isolation	Isolation	Isolation
+20mA	-15V at -20mA <sup>8</sup>	+20mA	+20mA	Isolation	Low Loss	Isolation	Isolation
+20mA	+20mA	-15V at -20mA <sup>8</sup>	+20mA	Isolation	Isolation	Low Loss	Isolation
+20mA	+20mA	+20mA	-15V at -20mA <sup>8</sup>	Isolation	Isolation	Isolation	Low Loss

8. The voltage applied to the off arm can vary as long as 20mA is applied through the shunt diode on the off arm.

## Application Circuit

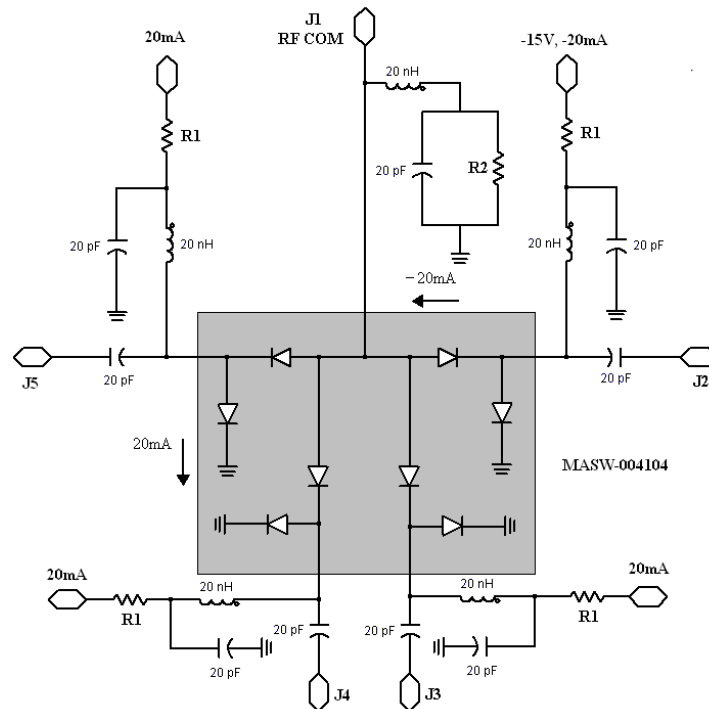

# MASW-004103-1365



HMIC™ Silicon PIN Diode SP4T Switch  
50 MHz - 20 GHz

Preliminary - Rev. V2P

## Outline Drawing Footprint

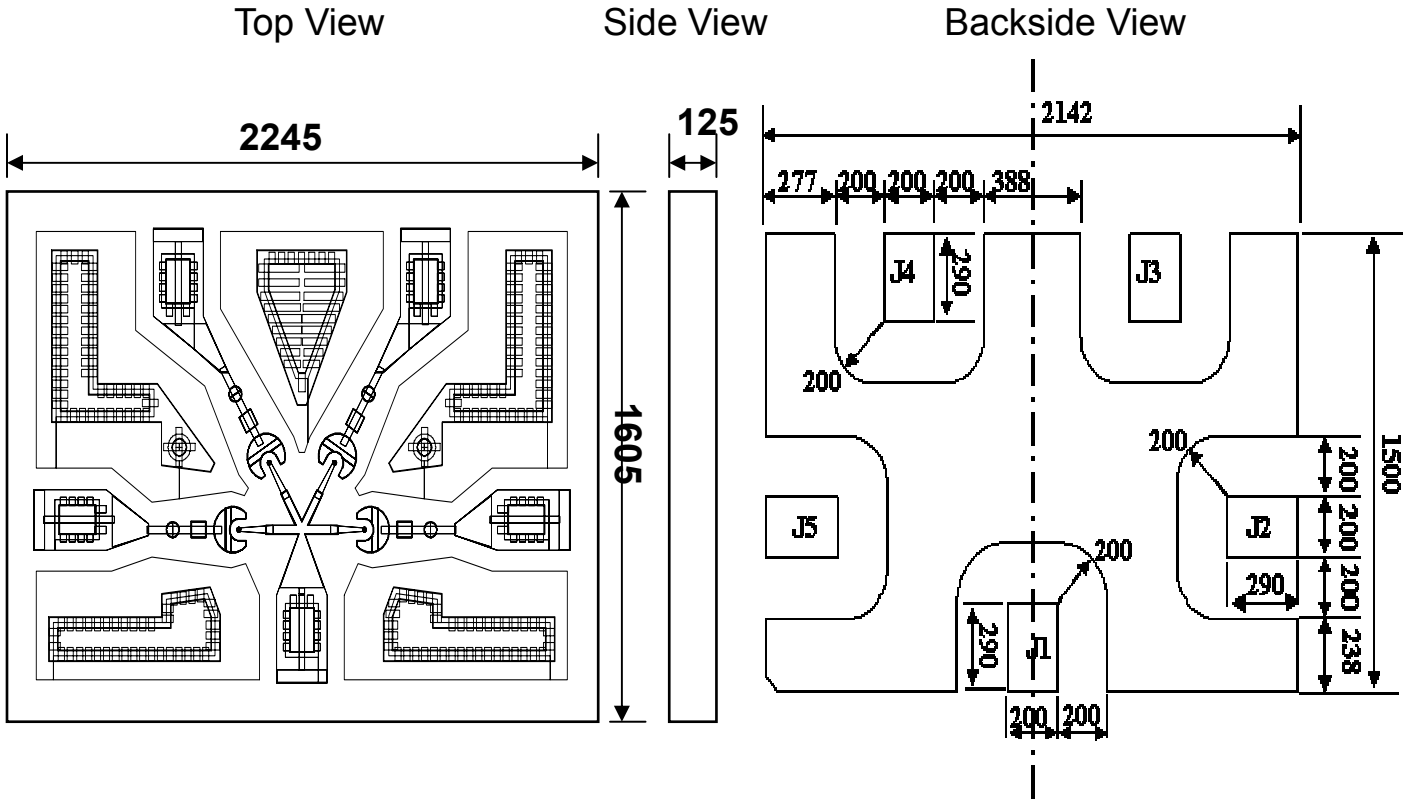

Units in μm

Backside view shows the back metal that is the foot print of the chip and all dimension are +/-0.5um

Ground radius is 200um centered on the I/O Pad.

MASW-004103-1365				
DIM	Inches		mm	
	MIN	MAX	MIN	MAX
Width	0.06220	0.06417	1.580	1.630
Length	0.08740	0.08937	2.220	2.270
Thickness	0.00394	0.00591	0.100	0.150

**ADVANCED:** Data Sheets contain information regarding a product M/A-COM Technology Solutions is considering for development. Performance is based on target specifications, simulated results, and/or prototype measurements. Commitment to develop is not guaranteed.  
**PRELIMINARY:** Data Sheets contain information regarding a product M/A-COM Technology Solutions has under development. Performance is based on engineering tests. Specifications are typical. Mechanical outline has been fixed. Engineering samples and/or test data may be available. Commitment to produce in volume is not guaranteed.

- **North America** Tel: 800.366.2266 / Fax: 978.366.2266
- **Europe** Tel: 44.1908.574.200 / Fax: 44.1908.574.300
- **Asia/Pacific** Tel: 81.44.844.8296 / Fax: 81.44.844.8298

Visit [www.macomtech.com](http://www.macomtech.com) for additional data sheets and product information.

M/A-COM Technology Solutions Inc. and its affiliates reserve the right to make changes to the product(s) or information contained herein without notice.

## Handling Procedures

Attachment to a circuit board is made simple through the use of standard surface mount technology. Mounting pads are conveniently located on the bottom surface of these devices and are removed from the active junction locations. These devices are well suited for solder attachment onto hard and soft substrates. The use of 80Au/20Sn, or RoHS compliant solders is recommended. For applications where the average power is  $\leq 1W$ , conductive silver epoxy may also be used. Cure per manufacturers recommended time and temperature. Typically 1 hour at 150°C.

When soldering these devices to a hard substrate, a solder re-flow method is preferred. A vacuum tip pick-up tool and a force of 60 to 100 grams applied to the top surface of the device while placing the chip is recommended. When soldering to soft substrates, such as Duroid, it is recommended to use a soft solder at the circuit board to mounting pad interface to minimize stress due to any TCE mismatches that may exist. Position the die so that its mounting pads are aligned with the circuit board mounting pads. Solder reflow should not be performed by causing heat to flow through the top surface of the die to the back. Since the HMIC glass is transparent, the edges of the mounting pads can be visually inspected through the die after attachment is completed.

Typical re-flow profiles for Sn60/Pb40 and RoHS compliant solders is provided in [Application Note M538](#), "Surface Mounting Instructions" and can be viewed on the MA-COM Technology Solutions website @ [www.macomtech.com](http://www.macomtech.com)

## Pocket Tape Information

### Carrier Tape Dimensions

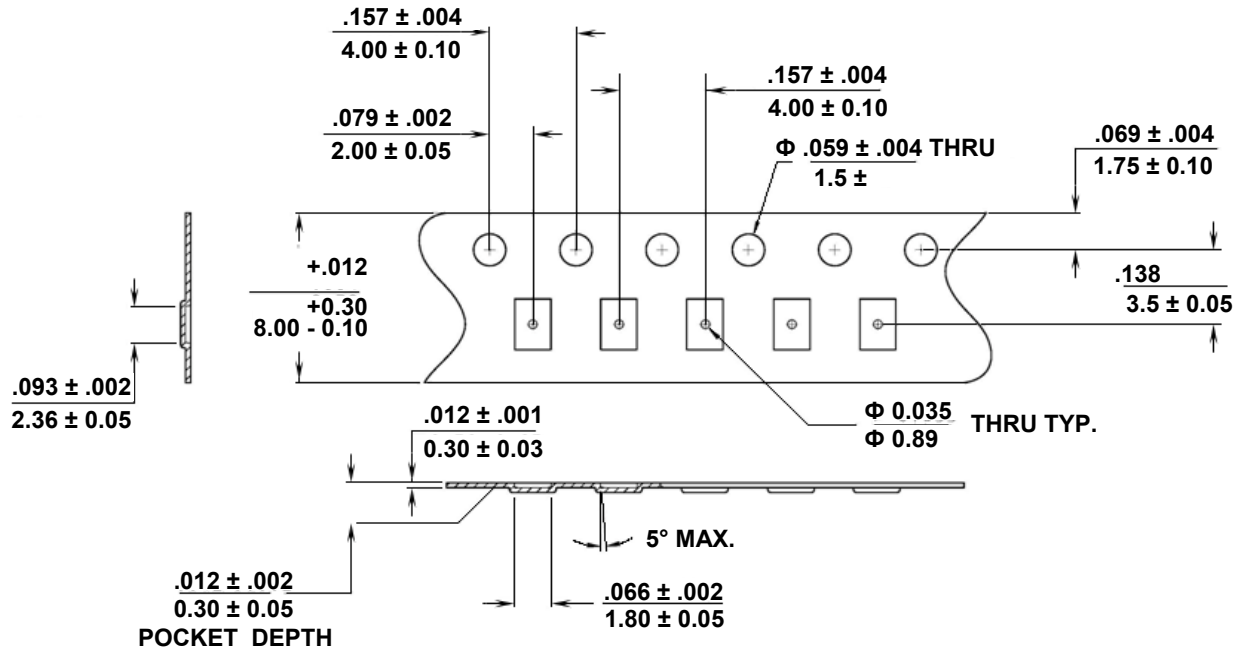

### Chip Orientation in Tape

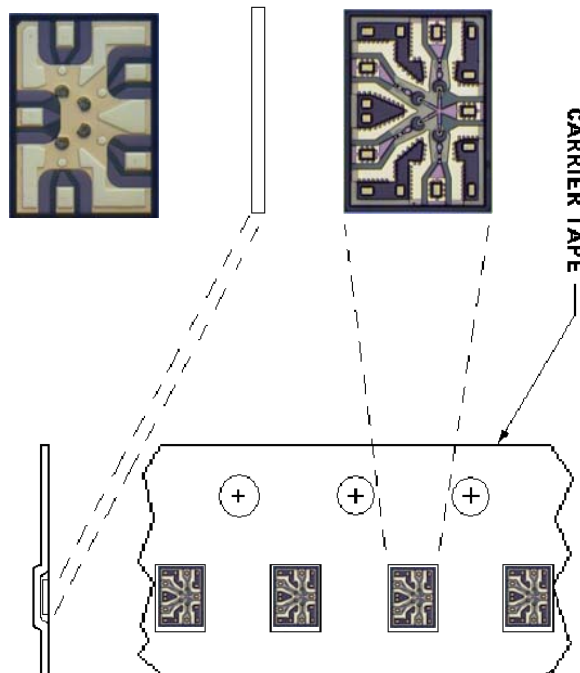

## Reel Information

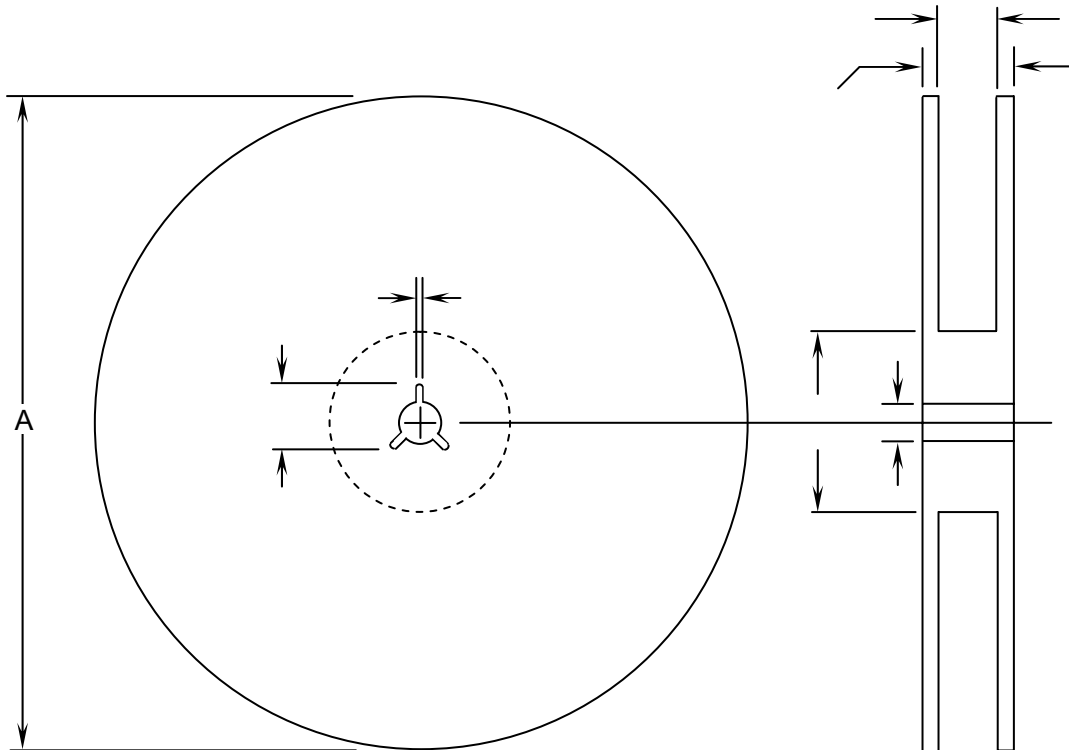

DIM	INCHES		MM	
	MIN.	MAX.	MIN.	MAX.
A	6.980	7.019	177.3	178.3
B	.059	.098	1.5	2.5
C	.504	.520	12.8	13.2
D	.795	.815	20.2	20.7
N	2.146	2.185	54.5	55.5
W <sub>1</sub>	.331	.337	8.4	8.55
W <sub>2</sub>	—	.567	—	14.4