



### Features

- Six and eight channels of ESD protection
- Provides  $\pm 15$  kV ESD protection on each channel per the IEC 61000-4-2 ESD requirements
- Channel loading capacitance of 1.6 pF typical
- Channel I/O to GND capacitance difference of 0.04pF typical
- Mutual capacitance of 0.13pF typical
- Minimal capacitance change with temperature and voltage
- Each I/O pin can withstand over 1000 ESD strikes
- SOIC and MSOP packages
- RoHs-compliant, lead-free packaging

### Applications

- IEEE1394 Firewire® ports at 400Mbps / 800Mbps
- DVI ports, HDMI ports in notebooks, set top boxes, digital TVs, LCD displays
- Serial ATA ports in desktop PCs and hard disk drives
- PCI Express ports
- General purpose high-speed data line ESD protection

### Product Description

The CM1216 family of diode arrays provide sESD protection for electronic components or sub-systems requiring minimal capacitive loading. These devices are ideal for protecting systems with high data and clock rates or for circuits requiring low capacitive loading. Each ESD channel consists of a pair of diodes in series which steer the positive or negative ESD current pulse to either the positive ( $V_P$ ) or negative ( $V_N$ ) supply rail. The CM1216 protects against ESD pulses up to  $\pm 15$ kV per the IEC 61000-4-2 standard.

This device is particularly well-suited for protecting systems using high-speed ports such as USB2.0, IEEE1394 (Firewire®, iLink™), Serial ATA, DVI, HDMI and corresponding ports in removable storage, digital camcorders, DVD-RW drives and other applications where extremely low loading capacitance with ESD protection are required in a small package footprint.

### Block Diagram

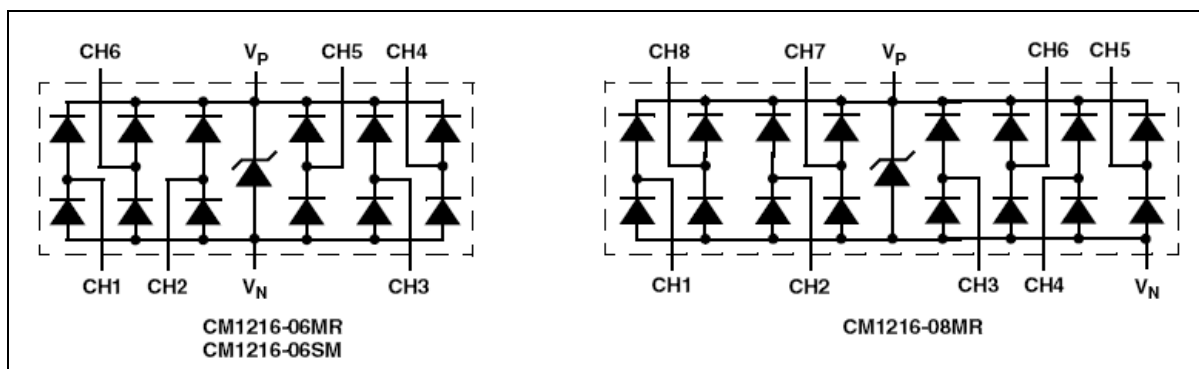

## Pin Configurations

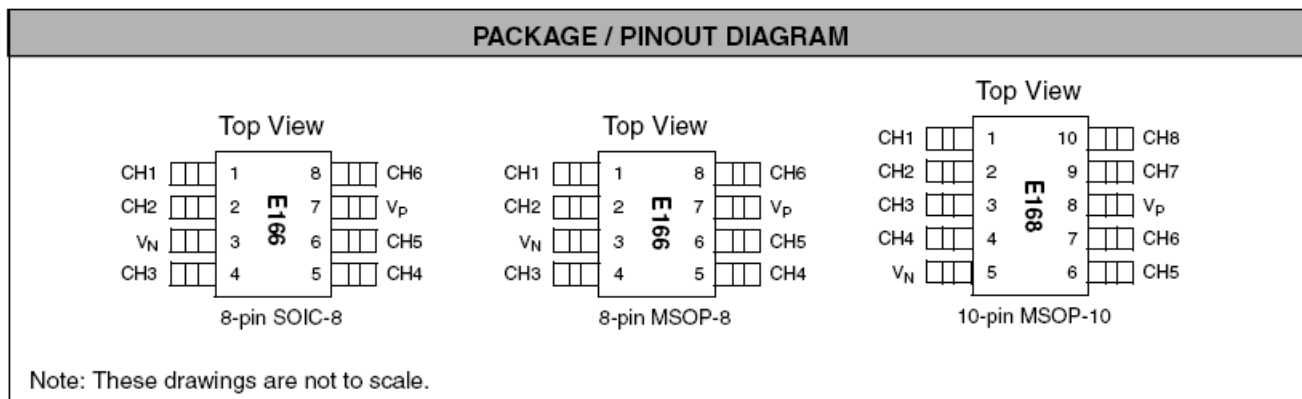

## Pin Information

<b>PIN DESCRIPTIONS</b>					
◆PIN NAME	MSOP-8	SOIC-8	MSOP-10	TYPE	DESCRIPTION
	PIN NO.	PIN NO.	PIN NO.		
CH1	1	1	1	I/O	ESD Channel
CH2	2	2	2	I/O	ESD Channel
CH3	4	4	3	I/O	ESD Channel
CH4	5	5	4	I/O	ESD Channel
$V_N$	3	3	5	GND	Negative voltage supply rail
CH5	6	6	6	I/O	ESD Channel
CH6	8	8	7	I/O	ESD Channel
$V_P$	7	7	8	PWR	Positive voltage supply rail
CH7	–	–	9	I/O	ESD Channel
CH8	–	–	10	I/O	ESD Channel

# CM1216

## Ordering Information

PART NUMBERING INFORMATION			
Pins	Package	Lead-free Finish	
		Ordering Part Number <sup>1</sup>	Part Marking
8	SOIC	CM1216-06SM	E166
8	MSOP	CM1216-06MR	E166
10	MSOP	CM1216-08MR	E168

Note 1: Parts are shipped in Tape and Reel form unless otherwise specified.

## Specifications

ABSOLUTE MAXIMUM RATINGS		
PARAMETER	RATING	UNITS
Operating Supply Voltage ( $V_P-V_N$ )	6	V
Diode Forward DC Current (Note 1)	20	mA
DC Voltage at any Channel Input	$(V_N-0.5)$ to $(V_P+0.5)$	V
Operating Temperature Range		
Ambient	-40 to +85	°C
Junction	-40 to +125	°C
Storage Temperature Range	-40 to +150	°C

## Standard Operating Conditions

STANDARD OPERATING CONDITIONS		
PARAMETER	RATING	UNITS
Temperature Range (Ambient)	-40 to +85	°C
Package Power Rating		
MSOP8 Package (CM1216-06MR)	400	mW
SOIC8 Package (CM1216-06SM)	600	mW
MSOP10 Package (CM1216-08MR)	400	mW

**ELECTRICAL OPERATING CHARACTERISTICS** NOTE 1

SYMBOL	PARAMETER	CONDITIONS	MIN	TYP	MAX	UNIT
$V_P$	Operating Supply Voltage ( $V_P-V_N$ )			3.3	5.5	V
$I_P$	Operating Supply Current	( $V_P-V_N$ ) = 3.3V			8	$\mu$ A
$V_F$	Diode Forward Voltage Top Diode Bottom Diode	$I_F = 20\text{mA}$ ; $T_A=25^\circ\text{C}$	0.6 0.6	0.8 0.8	0.95 0.95	V V
$I_{LEAK}$	Channel Leakage Current	$T_A = 25^\circ\text{C}$ ; $V_P=5\text{V}$ , $V_N=0\text{V}$		$\pm 0.1$	$\pm 1.0$	$\mu$ A
$C_{IN}$	Channel Input Capacitance	At 1 MHz, $V_P=3.3\text{V}$ , $V_N=0\text{V}$ , $V_{IN}=1.65\text{V}$ ;Note2		1.6	2.0	pF
$\Delta C_{IN}$	Channel Input Capacitance Matching			0.04		pF
$C_{MUTUAL}$	Mutual Capacitance	( $V_P-V_N$ ) = 3.3V		0.13		pF
$V_{ESD}$	ESD Protection Peak Discharge Voltage at any channel input, in system, contact discharge per IEC 61000-4- 2 standard	Notes 2 and 3; $T_A = 25^\circ\text{C}$	$\pm 15$			kV
$V_{CL}$	Channel Clamp Voltage Positive Transients Negative Transients	$I_{PP} = 1\text{A}$ , $t_p = 8/20\mu\text{S}$ ; $T_A=25^\circ\text{C}$		+9.0 -1.5		V V
$R_{DYN}$	Dynamic Resistance Positive transients Negative transients	$I_{PP} = 1\text{A}$ , $t_p = 8/20\mu\text{S}$ ; $T_A=25^\circ\text{C}$		0.6 0.4		$\Omega$ $\Omega$

Note 1: All parameters specified at  $T_A = -40^\circ\text{C}$  to  $+85^\circ\text{C}$  unless otherwise noted.

Note 2: Standard IEC 61000-4-2 with  $C_{Discharge} = 150\text{pF}$ ,  $R_{Discharge} = 330\Omega$ ,  $V_P = 3.3\text{V}$ ,  $V_N$  grounded.

Note 3: From I/O pins to  $V_P$  or  $V_N$  only.  $V_P$  bypassed to  $V_N$  with low ESR 0.2 $\mu$ F ceramic capacitor.

### Performance Characteristics

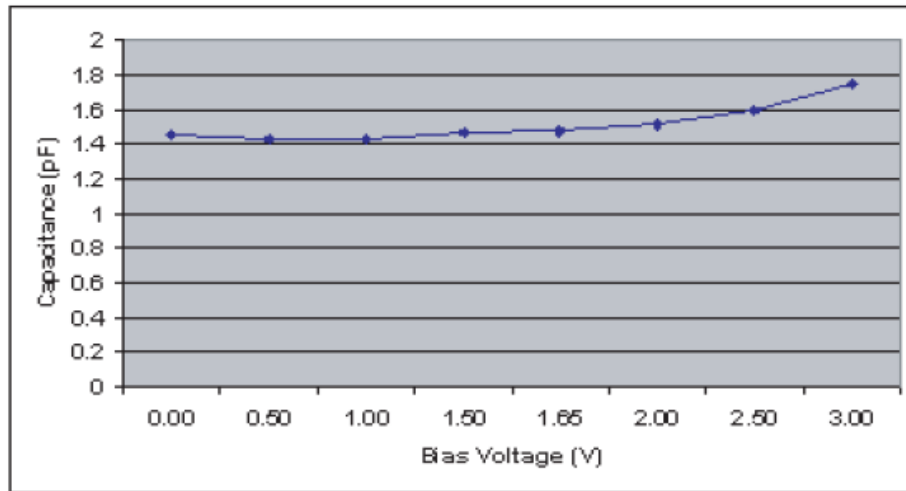

**Figure 1. Typical Variation of  $C_{IN}$  vs.  $V_{IN}$**   
( $f = 1\text{MHz}$ ,  $V_p = 3.3\text{V}$ ,  $V_N = 0\text{V}$ ,  $0.1\mu\text{F}$  chip capacitor between  $V_p$  and  $V_N$ ,  $T_A = 25\text{C}$ )

## Application Information

### Design Considerations

In order to realize the maximum protection against ESD pulses, care must be taken in the PCB layout to minimize parasitic series inductances on the Supply/Ground rails as well as the signal trace segment between the signal input (typically a connector) and the ESD protection device. Refer to Application of Positive ESD Pulse between Input Channel and Ground, which illustrates an example of a positive ESD pulse striking an input channel. The parasitic series inductance back to the power supply is represented by  $L_1$  and  $L_2$ . The voltage  $V_{CL}$  on the line being protected is:

$$V_{CL} = \text{Fwd voltage drop of } D_1 + V_{SUPPLY} + L_1 \times d(I_{ESD}) / dt + L_2 \times d(I_{ESD}) / dt$$

where  $I_{ESD}$  is the ESD current pulse, and  $V_{SUPPLY}$  is the positive supply voltage.

An ESD current pulse can rise from zero to its peak value in a very short time. As an example, a level 4 contact discharge per the IEC61000-4-2 standard results in a current pulse that rises from zero to 30 Amps in 1ns. Here  $d(I_{ESD})/dt$  can be approximated by  $\Delta I_{ESD}/\Delta t$ , or  $30/(1 \times 10^{-9})$ . So just 10nH of series inductance ( $L_1$  and  $L_2$  combined) will lead to a 300V increment in  $V_{CL}$ !

Similarly for negative ESD pulses, parasitic series inductance from the  $V_N$  pin to the ground rail will lead to drastically increased negative voltage on the line being protected.

The CM1213 has an integrated Zener diode between  $V_p$  and  $V_N$ . This greatly reduces the effect of supply rail inductance  $L_2$  on  $V_{CL}$  by clamping  $V_p$  at the breakdown voltage of the Zener diode. However, for the lowest possible  $V_{CL}$ , especially when  $V_p$  is biased at a voltage significantly below the Zener breakdown voltage, it is recommended that a 0.22µF ceramic chip capacitor be connected between  $V_p$  and the ground plane.

As a general rule, the ESD Protection Array should be located as close as possible to the point of entry of expected electrostatic discharges. The power supply bypass capacitor mentioned above should be as close to the  $V_p$  pin of the Protection Array as possible, with minimum PCB trace lengths to the power supply, ground planes and between the signal input and the ESD device to minimize stray series inductance.

### Additional Information

See also California Micro Devices Application Note AP209, "Design Considerations for ESD Protection", in the Applications section at [www.calmicro.com](http://www.calmicro.com).

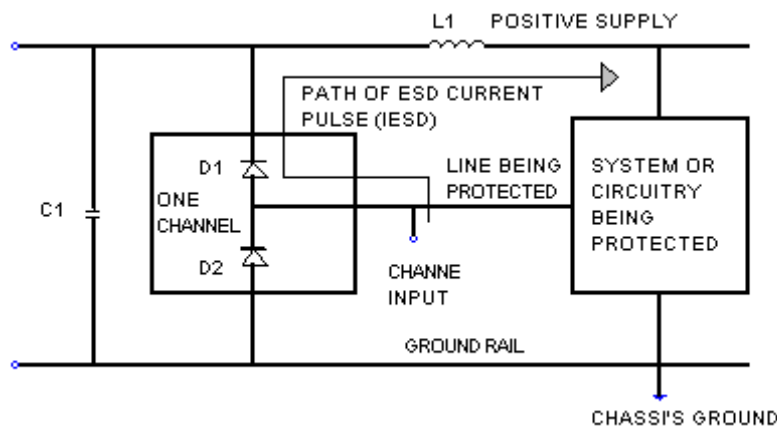

Figure 3. Application of Positive ESD Pulse between Input Channel and Ground

# CM1216

## Mechanical Details

The CM1216 is available in SOIC-8, MSOP-8, and MSOP-10 packages with a lead-free finishing.

### SOIC-8 Mechanical Specifications

The CM1216-06SM is supplied in an 8-pin SOIC package. Dimensions are presented below.

PACKAGE DIMENSIONS				
Package	SOIC			
Pins	8			
Dimensions	Millimeters		Inches	
	Min	Max	Min	Max
A	1.35	1.75	0.053	0.069
A <sub>1</sub>	0.10	0.25	0.004	0.010
B	0.33	0.51	0.013	0.020
C	0.19	0.25	0.007	0.010
D	4.80	5.00	0.189	0.197
E	3.80	4.19	0.150	0.165
e	1.27 BSC		0.050 BSC	
H	5.80	6.20	0.228	0.244
L	0.40	1.27	0.016	0.050
# per tape and reel	2500 pieces			
Controlling dimension: inches				

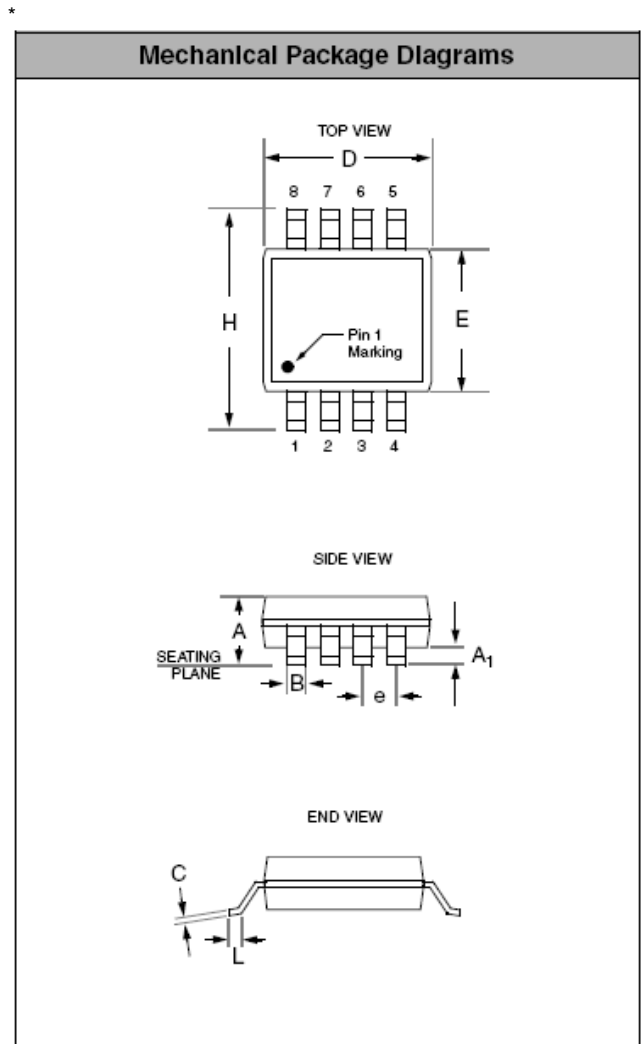

Package Dimensions for SOIC-8

**Tape and Reel Specifications**

PART NUMBER	PACKAGE SIZE (mm)	POCKET SIZE (mm) $B_0 \times A_0 \times K_0$	TAPE WIDTH W	REEL DIAMETER	QTY PER REEL	$P_0$	$P_1$
CM1216-06SM	4.90 X 6.00 X 1.55	5.30 X 6.50 X 2.10	12mm	330mm (13")	2500	4mm	8mm

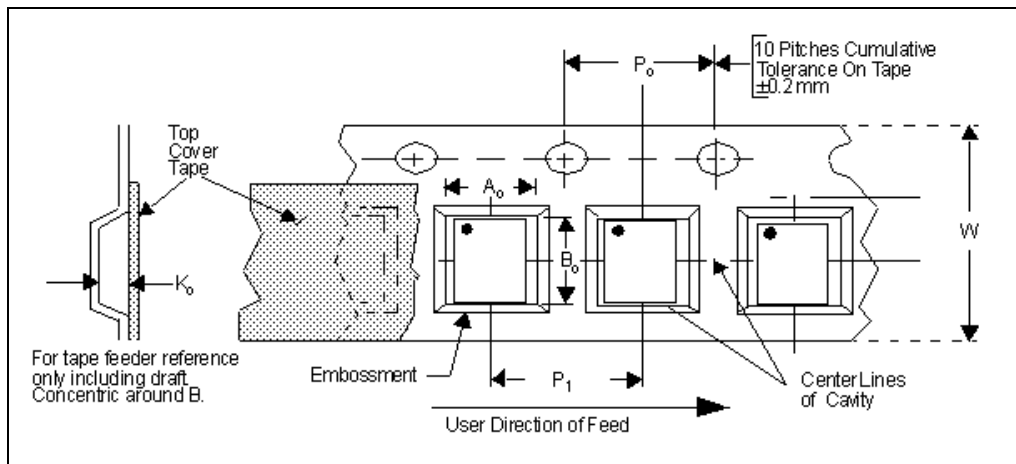



# CM1216

## Mechanical Details (Cont'd)

### MSOP-8 Mechanical Specifications:

The CM1216-06MR is supplied in an 8-pin MSOP package. Dimensions are presented below.

PACKAGE DIMENSIONS				
Package	MSOP			
Pins	8			
Dimensions	Millimeters		Inches	
	Min	Max	Min	Max
A	0.75	0.95	0.030	0.037
A1	0.05	0.15	0.002	0.006
B	0.28	0.38	0.011	0.015
C	0.13	0.23	0.005	0.009
D	2.90	3.10	0.114	0.122
E	2.90	3.10	0.114	0.122
e	0.65 BSC		0.026 BSC	
H	4.90 BSC		0.193 BSC	
L	0.40	0.70	0.016	0.028
# per tape and reel	4000 pieces			
Controlling dimension: millimeters				

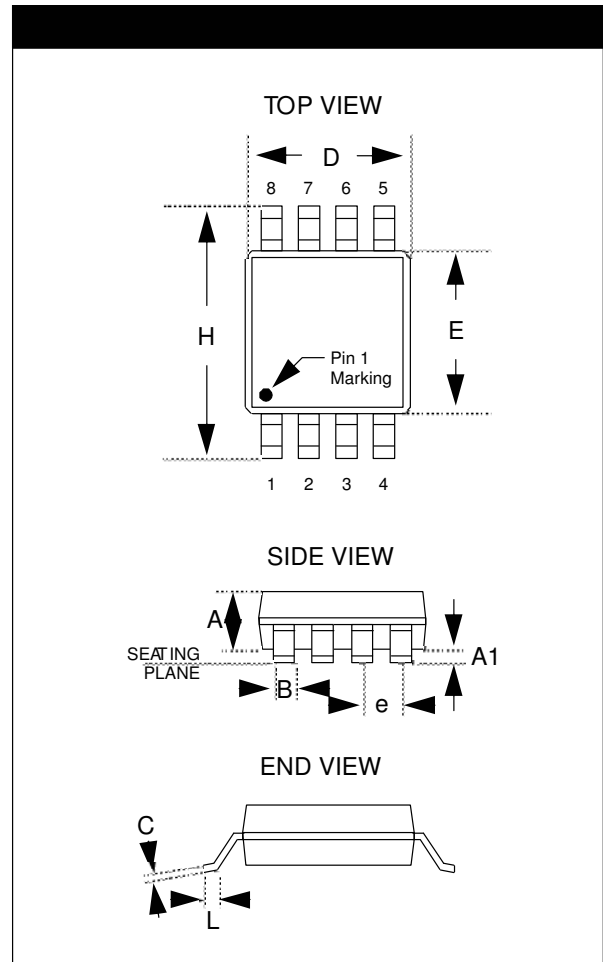

Package Dimensions for MSOP-8

**Tape and Reel Specifications**

PART NUMBER	PACKAGE SIZE (mm)	POCKET SIZE (mm) $B_0 \times A_0 \times K_0$	TAPE WIDTH W	REEL DIAMETER	QTY PER REEL	$P_0$	$P_1$
CM1213-06MR	3.00 X 3.00 X 0.85	3.3 X 5.3 X 1.3	12mm	330mm (13")	4000	4mm	8mm

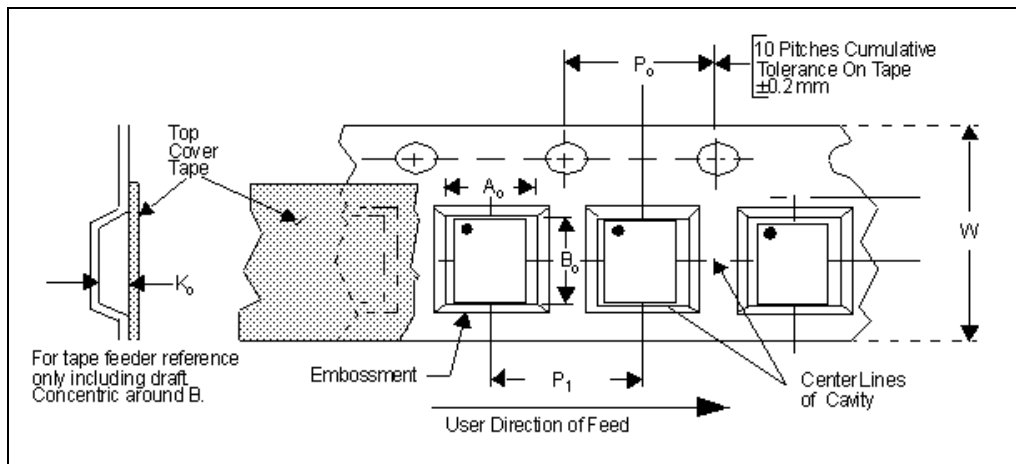

# CM1216

## Mechanical Details (cont'd)

### MSOP-10 Mechanical Specifications

The CM1213-08MR is supplied in a 10-pin MSOP package. Dimensions are presented below.

PACKAGE DIMENSIONS				
Package	MSOP			
Pins	10			
Dimensions	Millimeters		Inches	
	Min	Max	Min	Max
A	0.75	0.95	0.028	0.038
A1	0.05	0.15	0.002	0.006
B	0.17	0.33	0.007	0.013
C	0.13	0.23	0.005	0.009
D	2.90	3.10	0.114	0.122
E	2.90	3.10	0.114	0.122
e	0.50 BSC		0.0196 BSC	
H	4.90 BSC		0.193 BSC	
L	0.40	0.70	0.0137	0.029
# per tape and reel	4000			
Controlling dimension: inches				

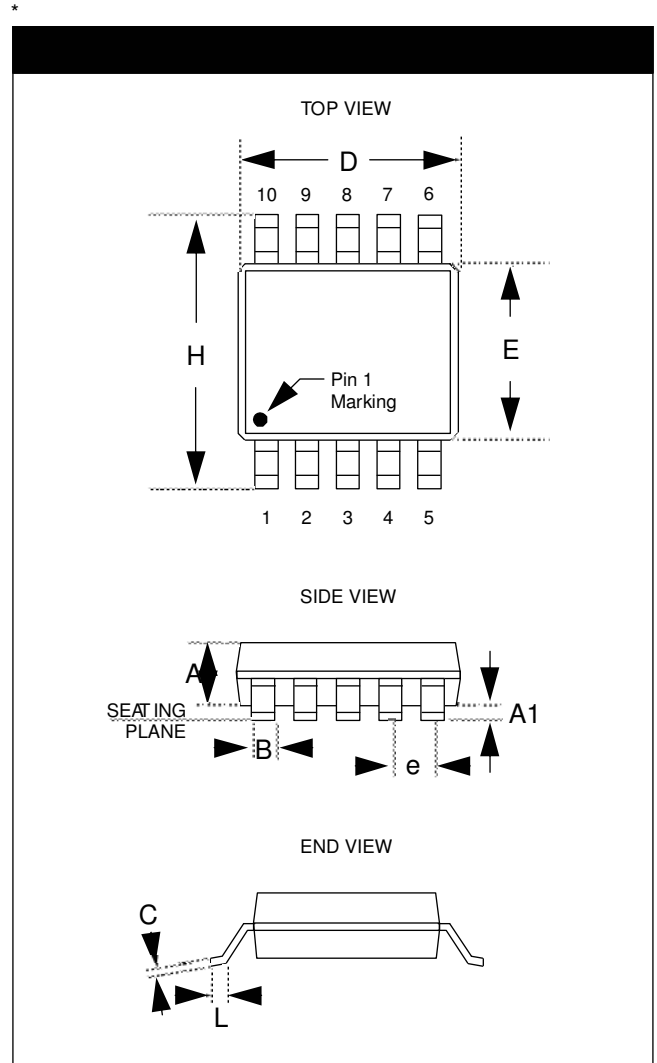

Package Dimensions for MSOP-10

Tape and Reel Specifications

PART NUMBER	PACKAGE SIZE (mm)	POCKET SIZE (mm) $B_0 \times A_0 \times K_0$	TAPE WIDTH W	REEL DIAMETER	QTY PER REEL	$P_0$	$P_1$
CM1216-08MR	3.00 X 3.00 X 0.85	3.3 X 5.3 X 1.3	12mm	330mm (13")	4000	4mm	8mm

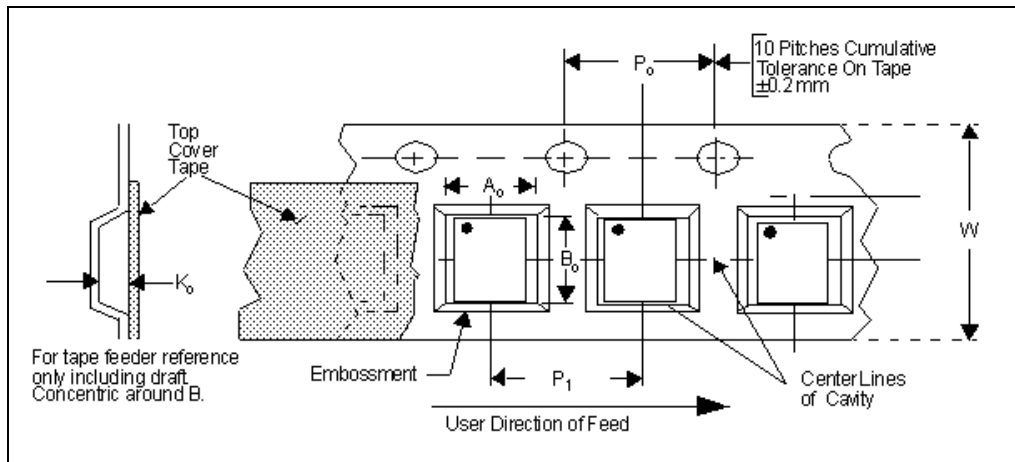

ON Semiconductor and  are registered trademarks of Semiconductor Components Industries, LLC (SCILLC). SCILLC reserves the right to make changes without further notice to any products herein. SCILLC makes no warranty, representation or guarantee regarding the suitability of its products for any particular purpose, nor does SCILLC assume any liability arising out of the application or use of any product or circuit, and specifically disclaims any and all liability, including without limitation special, consequential or incidental damages. "Typical" parameters which may be provided in SCILLC data sheets and/or specifications can and do vary in different applications and actual performance may vary over time. All operating parameters, including "Typicals" must be validated for each customer application by customer's technical experts. SCILLC does not convey any license under its patent rights nor the rights of others. SCILLC products are not designed, intended, or authorized for use as components in systems intended for surgical implant into the body, or other applications intended to support or sustain life, or for any other application in which the failure of the SCILLC product could create a situation where personal injury or death may occur. Should Buyer purchase or use SCILLC products for any such unintended or unauthorized application, Buyer shall indemnify and hold SCILLC and its officers, employees, subsidiaries, affiliates, and distributors harmless against all claims, costs, damages, and expenses, and reasonable attorney fees arising out of, directly or indirectly, any claim of personal injury or death associated with such unintended or unauthorized use, even if such claim alleges that SCILLC was negligent regarding the design or manufacture of the part. SCILLC is an Equal Opportunity/Affirmative Action Employer. This literature is subject to all applicable copyright laws and is not for resale in any manner.

## PUBLICATION ORDERING INFORMATION

### LITERATURE FULFILLMENT:

**Literature Distribution Center for ON Semiconductor**

**P.O. Box 5163, Denver, Colorado 80217 USA**

Phone: **303-675-2175 or 800-344-3860 Toll Free USA/Canada**

Fax: **303-675-2176 or 800-344-3867 Toll Free USA/Canada**

Email: [orderlit@onsemi.com](mailto:orderlit@onsemi.com)

N. American Technical Support: **800-282-9855**

**Toll Free USA/Canada**

Europe, Middle East and Africa Technical Support:

**Phone: 421 33 790 2910**

Japan Customer Focus Center

**Phone: 81-3-5773-3850**

**ON Semiconductor Website: [www.onsemi.com](http://www.onsemi.com)**

**Order Literature: <http://www.onsemi.com/orderlit>**

**For additional information, please contact your local Sales Representative**