



MASTER INSTRUMENT CORPORATION

**SINGLE-PHASE BRIDGE RECTIFIER
KBL005 THRU KBL10**

**VOLTAGE RANGE 50 to 1000 Volts
CURRENT 4.0 Amperes**

FEATURES

- l Low cost
- l This series is UL recognized under component index ,file number E127707
- l High forward surge current capability
- l Ideal for printed circuit board
- l High temperature soldering guaranteed:
260 °C/10 second, 0.375” (9.5mm) lead length at 5 lbs.(2.3kg) tension.

MECHANICAL DATA

- l Case: Transfer molded plastic
- l Terminal: Lead solderable per MIL-STD-202E method 208C
- l Mounting Postition: Any
- l Weight: 0.22ounce, 6.21gram

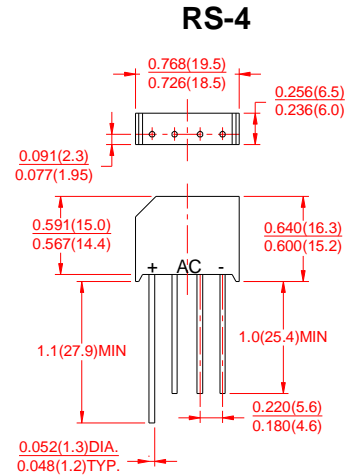

MAXIMUM RATINGS AND ELECTRICAL CHARACTERISTICS

Ratings at 25°C ambient temperature unless otherwise specified.
Single phase, half wave, 60Hz, resistive or inductive load.
For capacitive load derate current by 20%.

	SYMBOLS	KBL005	KBL01	KBL02	KBL04	KBL06	KBL08	KBL10	UNITS
Maximum Repetitive Peak Reverse Voltage	V_{RRM}	50	100	200	400	600	800	1000	Volts
Maximum RMS Voltage	V_{RMS}	35	70	140	280	420	560	700	Volts
Maximum DC Blocking Voltage	V_{DC}	50	100	200	400	600	800	1000	Volts
Maximum Average Forward Rectified Output Current, at	$T_C=50^{\circ}C$ (Note 2)	I_{AV}	4.0						Amps
	$T_A=50^{\circ}C$ (Note 3)		3.0						
Peak Forward Surge Current 8.3ms single half sine-wave superimposed on rated load (JEDEC Method)	I_{FSM}	200						Amps	
Rating for Fusing (t<8.3ms)	I^2t	166						A ² s	
Maximum Instantaneous Forward Voltage Drop per bridge element at 4.0A	V_F	1.0						Volts	
Maximum DC Reverse Current at rated DC blocking voltage per element	$T_A=25^{\circ}C$	I_R	10						μ Amps
	$T_A=100^{\circ}C$		1.0						mAmps
Typical Junction Capacitance (Note 1)	C_J	105						pF	
Typical Thermal Resistance (Note 2)	$R_{\theta JA}$	20						°C/W	
Operating and Storage Temperature Range	T_J, T_{STG}	-55 to +150						°C	

NOTES:

1. Measured at 1.0 MHz and applied reverse voltage of 4.0 Volts.
2. Unit mounted on 2.0”x1.6”x0.3” thick (5.0x4.0x0.08 cm) Al. plate.
3. P.C. Board mount with 0.5”x0.5” (12x12cm) copper pads 0.375” (9.5mm) lead length



MASTER INSTRUMENT CORPORATION

SINGLE-PHASE BRIDGE RECTIFIER
KBL005 THRU KBL10

VOLTAGE RANGE 50 to 1000 Volts
CURRENT 4.0 Amperes

RATINGS AND CHARACTERISTIC CURVES KBL005 THRU KBL10

