



SANYO Semiconductors

# DATA SHEET

## LA75525AVA

Monolithic Linear IC

For TV and VCR sets

### VIF/SIF Signal-Processing IC

#### Overview

The LA75525AVA is a completely adjustment-free NTSC VIF/SIF signal-processing IC for TV sets and VCRs. It supports IF frequencies of 45.75MHz. It integrates an automatic adjustment circuit for the VCO, an AFT circuit, and an audio carrier trap circuit on the same chip and requires the input of either a 4MHz or 3.58MHz reference signal.

#### Functions

- VIF block: VIF amplifier, buzz canceller, IF-VCO, PLL detector, IF-AGC, RF-AGC, digital AFT, equalizer amplifier
- 1stSIF block: 1stSIF amplifier, 1stSIF detector
- SIF block: Limiter amplifier, PLL FM detector
- Others: reference frequency changeover SW, AFT mute voltage SW

#### Specifications

Maximum Ratings at  $T_a = 25^\circ\text{C}$

Parameter	Symbol	Conditions	Ratings	Unit
Maximum supply voltage	$V_{CC\text{ max}}$		6	V
Circuit voltage	V12		$V_{CC}$	V
Circuit current	I5		-3	mA
	I9		-7	mA
	I24		-2	mA
Allowable power dissipation	$P_d\text{ max}$	$T_a \leq 75^\circ\text{C}$ , Mounted on a specified board *	500	mW
Operating temperature	$T_{opr}$		-20 to +75	$^\circ\text{C}$
Storage temperature	$T_{stg}$		-55 to +150	$^\circ\text{C}$

\* Specified board: 114.3mm×76.1mm×1.6mm, glass epoxy board.

■ Any and all SANYO Semiconductor Co.,Ltd. products described or contained herein are, with regard to "standard application", intended for the use as general electronics equipment (home appliances, AV equipment, communication device, office equipment, industrial equipment etc.). The products mentioned herein shall not be intended for use for any "special application" (medical equipment whose purpose is to sustain life, aerospace instrument, nuclear control device, burning appliances, transportation machine, traffic signal system, safety equipment etc.) that shall require extremely high level of reliability and can directly threaten human lives in case of failure or malfunction of the product or may cause harm to human bodies, nor shall they grant any guarantee thereof. If you should intend to use our products for applications outside the standard applications of our customer who is considering such use and/or outside the scope of our intended standard applications, please consult with us prior to the intended use. If there is no consultation or inquiry before the intended use, our customer shall be solely responsible for the use.

■ Specifications of any and all SANYO Semiconductor Co.,Ltd. products described or contained herein stipulate the performance, characteristics, and functions of the described products in the independent state, and are not guarantees of the performance, characteristics, and functions of the described products as mounted in the customer's products or equipment. To verify symptoms and states that cannot be evaluated in an independent device, the customer should always evaluate and test devices mounted in the customer's products or equipment.

SANYO Semiconductor Co., Ltd.

[www.semiconductor-sanyo.com/network](http://www.semiconductor-sanyo.com/network)

# LA75525AVA

## Recommended Operating Conditions at Ta = 25°C

Parameter	Symbol	Conditions	Ratings	Unit
Recommended supply voltage	V <sub>CC</sub>		5	V
Operation supply voltage	V <sub>CC op</sub>		4.5 to 5.5	V

## Electrical Characteristics at V<sub>CC</sub>=5V, S7, S9: Short

Parameter	Symbol	Conditions	Ratings			Unit
			min	typ	max	
<b>VIF Block</b>						
Circuit current (external trap)	I <sub>4</sub> (EXT)	External Trap	60	70	80	mA
Max RFAGC voltage	V <sub>14H</sub>		V <sub>CC</sub> -0.5	V <sub>CC</sub>		V
Min RFAGC voltage	V <sub>14L</sub>			0	0.5	V
Input sensitivity	V <sub>i</sub>	Video out2	34	40	46	dBμV
AGC range	GR		58	63		dB
Max allowable input	V <sub>i max</sub>		95	100		dBμV
No-signal state video output voltage (Ext TRAP)	V <sub>5</sub>		1.85	2.2	2.55	V
Sync signal edge voltage	V5tip		0.8	1.0	1.2	V
Video output level (External trap)	VOT		0.89	1.05	1.21	Vpp
Black noise threshold voltage	VBTH		0.40	0.65	0.90	V
Black noise clamp voltage	VBCL		1.2	1.5	1.8	V
Video S/N (External trap)	S/N(EXT)	External Trap	48	52		dB
C-S beat	IC-S	P/C = P/S = 10dB	38	43		dB
Frequency characteristics	Fc	6MHz	-3	-1.5		dB
Differential gain	DG			3	6.5	%
Differential phase	DP			3	5	deg
No-signal AFT voltage	V12	pin 15 to GND	2.0	2.5	3.0	V
Max AFT voltage	V12H		V <sub>CC</sub> -1	V <sub>CC</sub> -0.5	V <sub>CC</sub>	V
Min AFT voltage	V12L		0	0.18	1	V
AFT detection sensitivity	Sf		8.5	12.5	16.5	mV/kHz
AFT output resolution	Res-aft			3.125		kHz/bit
VIF input resistance	Ri			1.0		kΩ
VIF input capacity	Ci			3		pF
APC pull-in range (U)	Fpu		2.0	2.4		MHz
APC pull-in range (L)	Fpl			-2.4	-2.0	MHz
<b>1st SIF block: Pin 13 41.25MHz input</b>						
Conversion gain	VG	S = 40dBμ	37	43	49	dB
Output level	S <sub>O</sub>	S = 80dBμ	100	110	120	dBμV
SIF output gain	G <sub>bpf</sub>	Reference to SIF input (Pin 1)	0	3	6	dB
1st SIF max input	S <sub>i max</sub>		100	110		dBμV
1st SIF input resistance	R <sub>i</sub> (SIF)	41.25MHz		2		kΩ
1st SIF input capacity	C <sub>i</sub> (SIF)	41.25MHz		3		pF
<b>SIF block: Pin 13 41.25MHz input</b>						
Limiting sensitivity	V <sub>li</sub> (lim)		50	56	62	dBμV
FM detection output voltage	V <sub>O</sub> FM	+/-25kHz	420	600	780	mVrms
AMR	AMR		50	60		dB
Distortion factor	THD			0.3	0.8	%
SIF S/N	S/N(FM)		59	65		dB
<b>Control block</b>						
Inter carrier control voltage	V <sub>13</sub>				0.3	V
AFT mute level control voltage	V <sub>15</sub>				0.3	V
<b>Others</b>						
Reference clock input level	Reflev	4.0MHz	83	90	95	dBμV
Reference frequency SW threshold resistance value	R <sub>11</sub>		150	270		kΩ

# LA75525AVA

---

## A: IF system SW

The IF frequency becomes 45.75MHz when pin 10 is open.

## B: Split / Inter carrier SW

Inter-carrier is selected by setting the 1<sup>st</sup> SIF input (pin 13) to GND.

## C: Reference frequency changeover SW

The reference frequency becomes 4.0MHz when pin 11 is set to "C-①"

This frequency becomes 3.58MHz when this pin is set to "C-②"

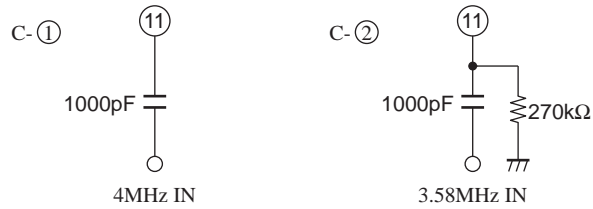

## D: AFT mute level

The AFT mute level becomes HI ( $V_{CC}$ ) when pin 15 is open.

This level becomes MIDDLE ( $V_{CC}/2$ ) when pin 15 is connected to GND.

\* For  $V_{CC} = 5\text{ V}$

# LA75525AVA

## Package Dimensions

unit : mm (typ)

3287

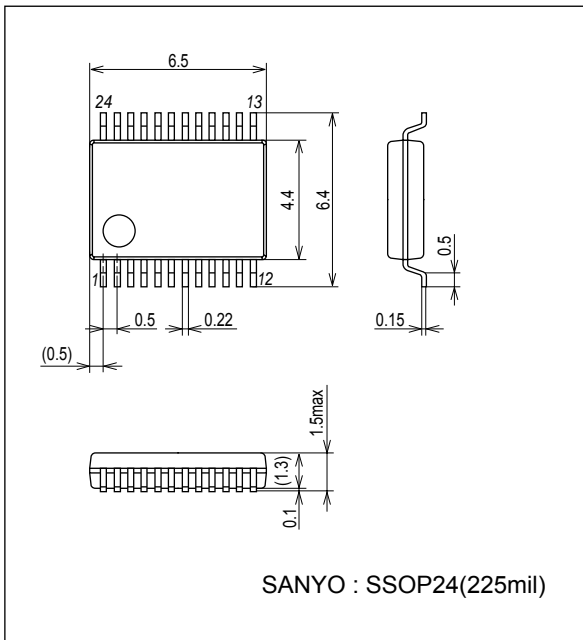

## Pin Assignment

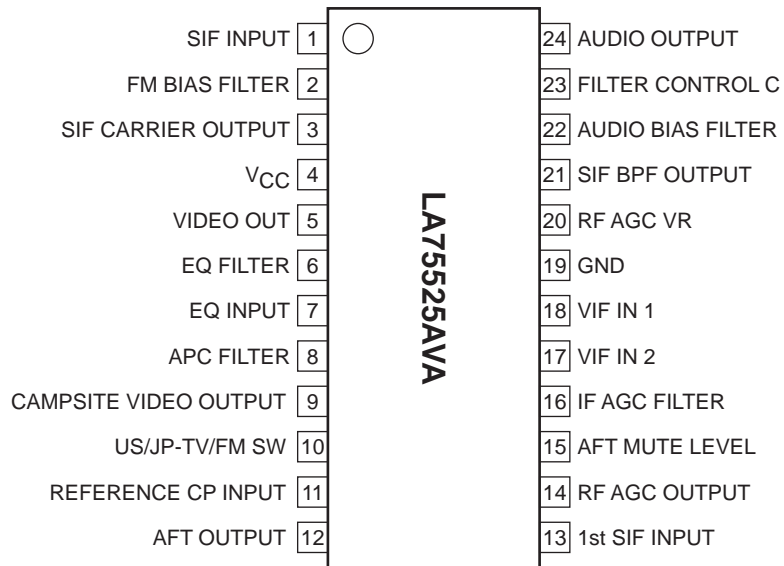

Top View

# LA75525AVA

## Block Diagram

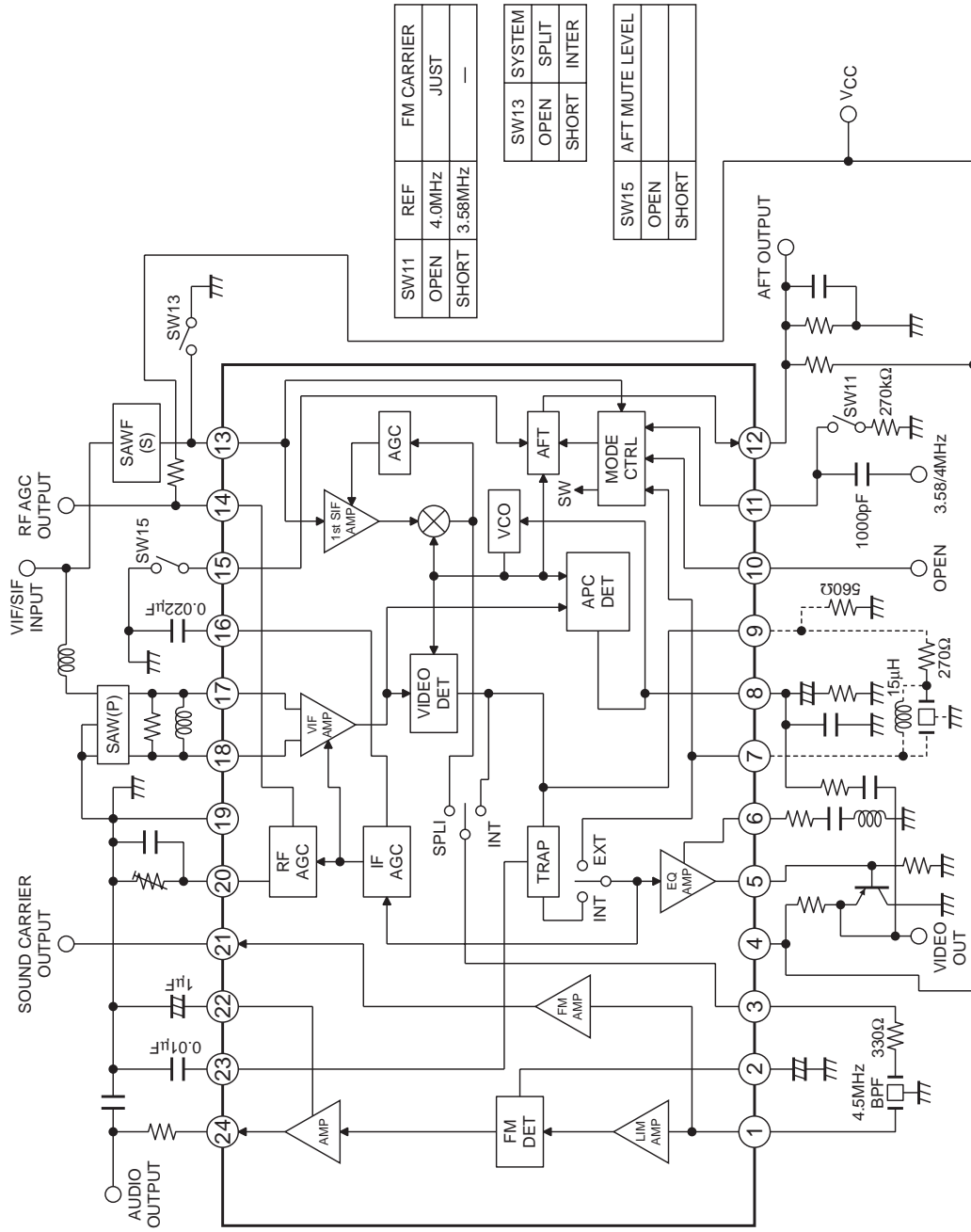

SW11	REF	FM CARRIER
OPEN	4.0MHz	JUST
SHORT	3.58MHz	—

SW13	SYSTEM
OPEN	SPLIT
SHORT	INTER

SW15	AFT MUTE LEVEL
OPEN	
SHORT	

# LA75525AVA

## Pin Function

Pin No.	Pin name	Function	Equivalent circuit
1	SIF INPUT	<p>SIF input. The input impedance is about 1kΩ. Since buzzing and buzz beating can occur if interference enters this input pin, care must be taken when design the pattern layout for this pin. Note that the video and chrominance signals are especially likely to interface with the audio signal. Also, the VIF carrier signal can also cause interference.</p> <p>By SW1, Gain at the time of Intercarrier and Split system is switched.</p>	
2	FM BIAS FILTER	<p>FM detector bias line filter input. Used to improve the FM detector signal-to-noise ratio. C1 should be at least 0.47μF, and 1μF is recommended. If the FM detector is not used, connect pin 2 to ground through a 2kΩ resistor. This stops the FM detector VCO.</p>	
3	SIF CARRIER OUTPUT	<p>SIF carrier output. A 200Ω resistor is inserted in series with an emitter-follower output.</p>	
4	VCC	Use the shortest distance possible when decoupling Capacitors VCC and ground.	
5 6 7	VIDEO OUT EQ FILTER EQ INPUT	<p>Equalizer circuit. This circuit is used to correct the video signal frequency characteristics. Pin 7 is the EQ amplifier input.</p> <p>Notes on equalizer amplifier is designed as a gain of about 0dB. when user for frequency characteristics correction, a capacitor, inductor, and resistor must be connected in series between pin 6 and ground.</p> <p>Approach used in the equalizer amplifier If Vi the input signal and VO is the output signal, then:</p> $\frac{R1}{2} + 1(Vi + Vin) = VO \times G$ <p>Where G is the voltage-follower amplifier gain. Assume: Vin: Imaginary short G ≈ 0. Vin ≈ 0.</p> <p>Then: <math>AV = \frac{VOG}{Vi} = \frac{R1}{Z} + 1</math></p> <p>R1 is the IC internal resistance, and is 1kΩ. In the application design, simply select Z to correspond to the desired characteristics. However, since the EQ amplifier gain will be maximum at the resonant point defined by Z, care is required to assure that distortion dose not occur.</p>	

Continued on next page.

# LA75525AVA

Continued from preceding page.

Pin No.	Pin name	Function	Equivalent circuit
8	APC FILTER	PLL detector APC filter connection. For this APC filter we recommend: R = 150Ω C = 0.47μF	
9	COMPOSIT VIDEO OUTPUT	Output for the video signal that includes the SIF carrier. A resistor must be inserted between pin 9 and ground to acquire adequate drive capability R2 ≥ 560Ω	
10	US/JP-TV/FM SW	Please use this pin only with OPEN.	
11	REFERENCE CP INPUT	Reference frequency input from this pin. The reference frequency is 3.58MHz, inserting 270kΩ between this pin to GND. The reference frequency is 4.0MHz, this pin leaving open.	
12	AFT OUTPUT	AFT output. AFT center voltage is generated by an external bleeder. The AFT gain is increased by increasing the resistance of this external bleeder resistor. However, this resistor must not exceed 390Ω. This circuit includes a control function that control the AFT voltage to naturally approach the center voltage during weak field reception.	

Continued on next page.

# LA75525AVA

Continued from preceding page.

Pin No.	Pin name	Function	Equivalent circuit
13	1st SIF INPUT	<p>First SIF input. ADC cut capacitor must be used in the input circuit.</p> <p>If a SAW filter is used: The first SIF sensitivity can be increased by inserting an inductor between the SAW filter and the IC to neutralize the SAW filter output capacitance and the IC input capacitance.</p> <p>When used in an intercarrier system: This pin (pin 13) maybe connect to GND.</p>	
	RF AGC OUTPUT	<p>RF AGC OUT PUT. This output controls the tuner RF AGC.</p> <p>A protective 200Ω resistor is inserted in series with the open collector out put. Determine the external bleeder resistor value in accordance with the specifications of the tuner.</p>	
15	AFT MUTE LEVEL	<p>The MUTE voltage of AFT is set up this pin. It becomes a voltage that generated by an external bleeder resistor, when this pin is connected with GND. It becomes a High voltage (<math>V_{CC}</math>) when this pin is leaving open.</p>	
16	IF AGC INPUT	<p>IF AGC filter connection.</p> <p>The signal peak-detected by the built-in AGC detector is converted to the AGC voltage at pin 16. Additionally, a second AGC filter (a lag-lead filter) used to create the dual time constants is provided internally in the IC.</p> <p>Use a 0.022μF capacitor as the external capacitor, and other characteristics.</p>	
17	VIF IN 2	VIF amplifier input.	
18	VIF IN 1	<p>The input circuit is a balanced circuit, and the input constants are: <math>R = 1.0k\Omega</math> <math>C = 3pF</math></p>	
19	GND	GND	

Continued on next page.



# LA75525AVA

Continued from preceding page.

Pin No.	Pin name	Function	Equivalent circuit
20	RF AGC VR	RF AGC VR connection. This pin sets the tuner RF AGC operating point. Also, the FM output and the video output can both be muted the same time by connecting this pin to GND.	
21	SIF BPF OUTPUT	The output to the external band-pass filter is passed through an internal 6dB amplifier before being output.	
22	AUDIO BIAS FILTER	Connection for a filter used to hold the FM detector output DC voltage fixed. Normally, a 1μF electrolytic capacitor should be used. The capacitance should be increased if the low band (around 50Hz) frequency characteristics need to be improved. The FM detector output level can be reduced and the FM dynamic range can be increased by inserting a resistor and a capacitor in series between pin 22 and GND.	
23	FILTER CONTROL C	Internal sound carrier TRAP are tuned using the capacitor connected to pin 23. A value between 0.47μF and 1μF is considered desirable taking video S/N, and AM and PM noise into consideration.	
24	AUDIO OUTPUT	Audio FM detector output. A 54kΩ resistor is inserted in series with an emitter-follower output. For applications that support mono: Create an external de-emphasis circuit. $t = C1 \times R1$	

- SANYO Semiconductor Co.,Ltd. assumes no responsibility for equipment failures that result from using products at values that exceed, even momentarily, rated values (such as maximum ratings, operating condition ranges, or other parameters) listed in products specifications of any and all SANYO Semiconductor Co.,Ltd. products described or contained herein.
- SANYO Semiconductor Co.,Ltd. strives to supply high-quality high-reliability products, however, any and all semiconductor products fail or malfunction with some probability. It is possible that these probabilistic failures or malfunction could give rise to accidents or events that could endanger human lives, trouble that could give rise to smoke or fire, or accidents that could cause damage to other property. When designing equipment, adopt safety measures so that these kinds of accidents or events cannot occur. Such measures include but are not limited to protective circuits and error prevention circuits for safe design, redundant design, and structural design.
- In the event that any or all SANYO Semiconductor Co.,Ltd. products described or contained herein are controlled under any of applicable local export control laws and regulations, such products may require the export license from the authorities concerned in accordance with the above law.
- No part of this publication may be reproduced or transmitted in any form or by any means, electronic or mechanical, including photocopying and recording, or any information storage or retrieval system, or otherwise, without the prior written consent of SANYO Semiconductor Co.,Ltd.
- Any and all information described or contained herein are subject to change without notice due to product/technology improvement, etc. When designing equipment, refer to the "Delivery Specification" for the SANYO Semiconductor Co.,Ltd. product that you intend to use.
- Information (including circuit diagrams and circuit parameters) herein is for example only; it is not guaranteed for volume production.
- Upon using the technical information or products described herein, neither warranty nor license shall be granted with regard to intellectual property rights or any other rights of SANYO Semiconductor Co.,Ltd. or any third party. SANYO Semiconductor Co.,Ltd. shall not be liable for any claim or suits with regard to a third party's intellectual property rights which has resulted from the use of the technical information and products mentioned above.

This catalog provides information as of April, 2009. Specifications and information herein are subject to change without notice.