

SI-8000JD Series

Surface-Mount, Separate Excitation Step-down Switching Mode Regulator ICs

Features

- Surface-mount package (TO263-5)
- Output current: 1.5A
- High efficiency: 77 to 88%
- Requires only 4 discrete components
- Internally-adjusted phase correction and output voltage
- Capable of downsizing a choke-coil due to IC's high switching frequency (125 kHz). (Compared with conventional Sanken devices)
- Built-in foldback-overcurrent and thermal protection circuits
- Output ON/OFF available (Circuit current at output OFF: 200 μ A max)
- Soft start available by ON/OFF pin Conditions

Lineup

Part Number	SI-8033JD	SI-8050JD	SI-8090JD	SI-8120JD
Vo(V)	3.3	5.0	9.0	12.0
Io(A)	1.5			

Absolute Maximum Ratings

Parameter	Symbol	Ratings	Unit	Conditions
DC Input Voltage	V _{IN}	43	V	
Output Current	I _o	1.5	A	
Power Dissipation*	P _D	3	W	When mounted on glass-epoxy board 40 × 40 mm (copper area 100%)
Junction Temperature	T _j	+125	°C	
Storage Temperature	T _{stg}	-40 to +125	°C	
Thermal Resistance (Junction to Case)	θ_{jc}	3	°C/W	
Thermal Resistance (Junction to Ambient Air)	θ_{ja}	33.3	°C/W	When mounted on glass-epoxy board 40 × 40 mm (copper area 100%)

*: Limited by thermal protection circuit

Applications

- Power supplies for telecommunication equipment
- Onboard local power supplies, etc.

Recommended Operating Conditions

Parameter	Symbol	Ratings				Unit	Conditions
		SI-8033JD	SI-8050JD	SI-8090JD	SI-8120JD		
DC Input Voltage Range	V _{IN1}	5.3 to 40	7 to 40	11 to 40	14 to 40	V	I _o =0 to 1A
	V _{IN2}	6.3 to 40	8 to 40	12 to 40	15 to 40		I _o =0 to 1.5A
DC Output Current Range*	I _o	0 to 1.5				A	V _{IN} ≥V _O +3V
Operating Junction Temperature Range	T _{top}	-30 to +125				°C	
Operating Temperature Range*	T _{op}	-30 to +125				°C	

*: Limited by Ta–Pd characteristics

Electrical Characteristics

(T_a=25°C)

Parameter	Symbol	Ratings												Unit
		SI-8033JD			SI-8050JD			SI-8090JD			SI-8120JD			
		min.	typ.	max.	min.	typ.	max.	min.	typ.	max.	min.	typ.	max.	
Output Voltage	V _o	3.234	3.30	3.366	4.90	5.00	5.10	8.82	9.00	9.18	11.76	12.00	12.24	V
	Conditions	V _{IN} =15V, I _o =0.5A			V _{IN} =20V, I _o =0.5A			V _{IN} =21V, I _o =0.5A			V _{IN} =24V, I _o =0.5A			
Efficiency	η	77			82			86			88			%
	Conditions	V _{IN} =15V, I _o =0.5A			V _{IN} =20V, I _o =0.5A			V _{IN} =21V, I _o =0.5A			V _{IN} =24V, I _o =0.5A			
Oscillation Frequency	f	125			125			125			125			kHz
	Conditions	V _{IN} =15V, I _o =0.5A			V _{IN} =20V, I _o =0.5A			V _{IN} =21V, I _o =0.5A			V _{IN} =24V, I _o =0.5A			
Line Regulation	Δ V _{OLINE}	25 80			40 100			50 120			60 130			mV
	Conditions	V _{IN} =8 to 30V, I _o =0.5A			V _{IN} =10 to 30V, I _o =0.5A			V _{IN} =15 to 30V, I _o =0.5A			V _{IN} =18 to 30V, I _o =0.5A			
Load Regulation	Δ V _{OLOAD}	10 30			10 40			10 40			10 40			mV
	Conditions	V _{IN} =15V, I _o =0.2 to 0.8A			V _{IN} =20V, I _o =0.2 to 0.8A			V _{IN} =21V, I _o =0.2 to 0.8A			V _{IN} =24V, I _o =0.2 to 0.8A			
Temperature Coefficient of Output Voltage	Δ V _o /ΔT _a	±0.5			±0.5			±1.0			±1.0			mV/°C
Overcurrent Protection Starting Current	I _{st}	1.6			1.6			1.6			1.6			A
	Conditions	V _{IN} =15V			V _{IN} =20V			V _{IN} =21V			V _{IN} =24V			
ON/OFF* Pin	Low Level Voltage	V _{SSL}			0.5			0.5			0.5			V
	Outflow Current at Low Voltage	I _{SSL}			100			100			100			
Quiescent Circuit Current	I _q	7			7			7			7			mA
		Conditions	V _{IN} =15V, I _o =0A			V _{IN} =20V, I _o =0A			V _{IN} =21V, I _o =0A			V _{IN} =24V, I _o =0A		
	I _{q(OFF)}	200			200			200			200			μ A
		Conditions	V _{IN} =15V, V _{ON/OFF} =0.3V			V _{IN} =20V, V _{ON/OFF} =0.3V			V _{IN} =21V, V _{ON/OFF} =0.3V			V _{IN} =24V, V _{ON/OFF} =0.3V		

*: Pin 5 is the ON/OFF pin. Soft start at power on can be performed with a capacitor connected to this pin.

The output can also be turned ON/OFF with this pin.

The output is stopped by setting the voltage of this pin to V_{SSL} or lower.

ON/OFF-pin voltage can be changed with an open-collector drive circuit of a transistor.

When using both the soft-start and ON/OFF functions together, the discharge current from C₃ flows into the ON/OFF control transistor. Therefore, limit the current securely to protect the transistor if C₃ capacitance is large.

The ON/OFF pin is pulled up to the power supply in the IC, so applying the external voltage is prohibited.

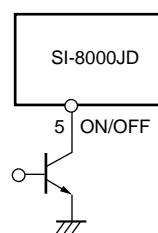

V_{OUT}. ON/OFF

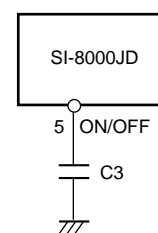

Soft Start

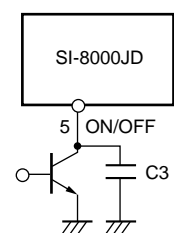

Soft Start +V_{OUT}. ON/OFF

External Dimensions (TO263-5)

(Unit : mm)

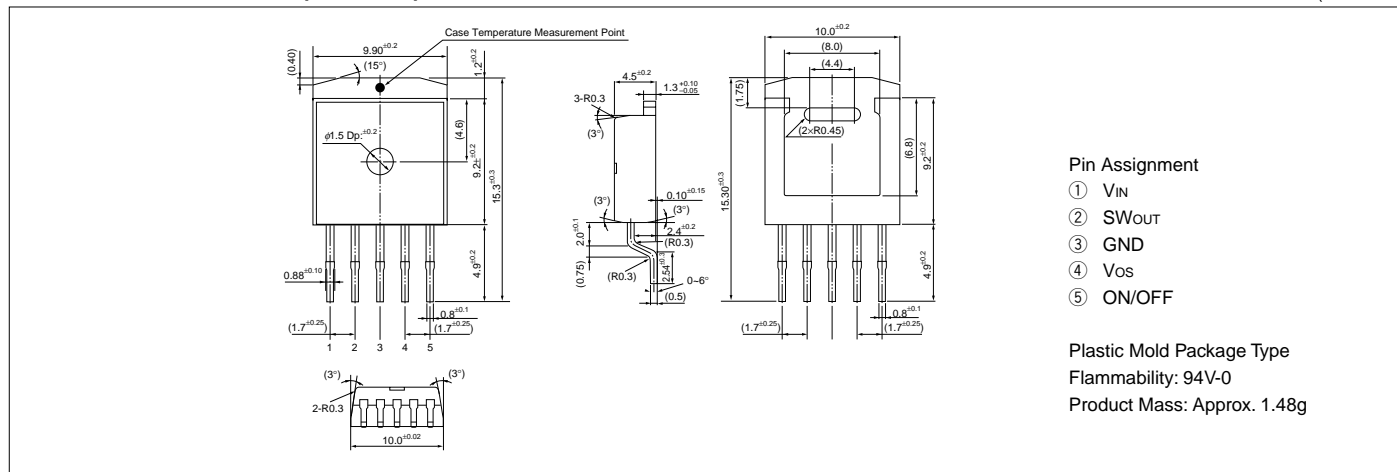

Block Diagram

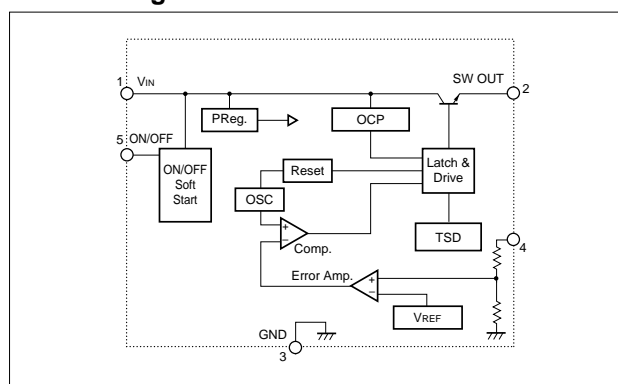

Typical Connection Diagram

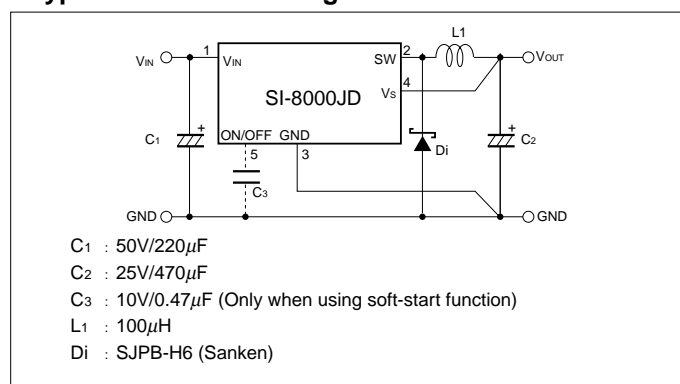

Reference Data

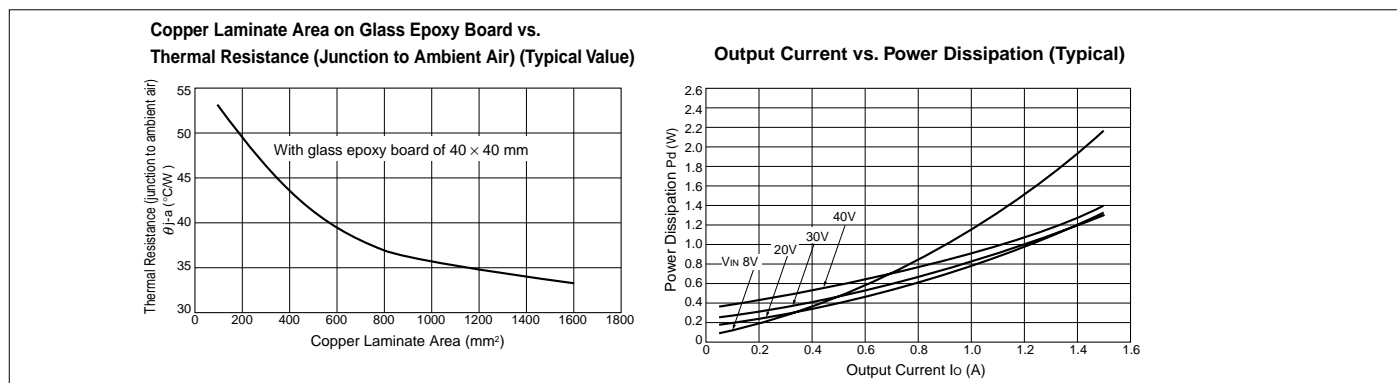

Ta-Pd Characteristics

