

# ±1°C Remote and Local Temperature Sensor with SMBus Serial Interface

## ■ FEATURES

- **Two channels:** measures both remote and local temperatures
- **No calibration required**
- **SMBus 2-wire serial interface**
- **Programmable under/over-temperature alarms**
- **SMBus alert response supported**
- **Accuracy:**
  - ±1°C (+60°C to +100°C, remote)
  - ±3°C (+60°C to + 100°C, local)
- **Average supply current during conversion of 320µA (typ)**
- **Supply range of +3V to +5.5V**
- **Small 8-lead SO package**

## ■ APPLICATIONS

Desktop and Notebook Computers	Central Office Telecom Equipment
Smart Battery Packs	Test and Measurement
LAN Servers	Multi-Chip Modules
Industrial Controllers	

## ■ DESCRIPTION

The SS8018 is a precise digital thermometer that reports the temperature of both a remote sensor and its own package. The remote sensor is a diode-connected transistor - typically a low-cost, easily mounted 2N3904 NPN type that replaces a conventional thermistor or thermocouple. Remote accuracy is ±1°C with no calibration needed. The remote channel can also measure the die temperature of other ICs, such as microprocessors, that contain an on-chip, diode-connected transistor.

The 2-wire serial interface accepts standard System Management Bus (SMBus) Write Byte, Read Byte, Send Byte, and Receive Byte commands to program the alarm thresholds and to read temperature data. The data format is 11bits plus sign, with each bit corresponding to 0.125°C, in two's-complement format. Measurements can be done automatically and autonomously, with the conversion rate programmed by the user or programmed to operate in a single-shot mode. The adjustable rate allows the user to control the supply current drain.

The SS8018 is available in a small 8-pin SOP surface-mount package.

## ■ ORDERING INFORMATION

SS8018XX

└─ PACKING TYPE  
TR: TAPE & REEL

Example: SS8018TR

→ SS8018 shipped in  
tape & reel packing

## ■ ABSOLUTE MAXIMUM RATINGS

VCC to GND.....	-0.3V to +6V
DXP to GND.....	-0.3V to VCC + 0.3V
DXN to GND.....	-0.3V to +0.8V
SMBCLK, SMBDATA, $\overline{\text{ALERT}}$ to GND.....	-0.3V to +6V
SMBDATA, $\overline{\text{ALERT}}$ Current.....	-1mA to +50mA
DXN Current.....	±1mA
ESD Protection (SMBCLK, SMBDATA, $\overline{\text{ALERT}}$ , human body model).....	2000V
ESD Protection (other pins, human body model).....	2000V
Continuous Power Dissipation ( $T_A = +70^\circ\text{C}$ ) .....	SOP
(derate 8.30mW/ $^\circ\text{C}$ above $+70^\circ\text{C}$ ).....	667mW
Operating Temperature Range.....	-20 $^\circ\text{C}$ to +120 $^\circ\text{C}$
Junction Temperature.....	+150 $^\circ\text{C}$
Storage temperature Range.....	-65 $^\circ\text{C}$ to +165 $^\circ\text{C}$
Lead Temperature (soldering, 10sec).....	+300 $^\circ\text{C}$

## ■ ELECTRICAL CHARACTERISTICS

(VCC = + 3.3V,  $T_A = 0^\circ\text{C}$  to +85 $^\circ\text{C}$ , unless otherwise noted.)

PARAMETER	CONDITIONS	MIN	TYP	MAX	UNITS
Temperature Error, Remote Diode (Note 1)	$T_R = +60^\circ\text{C}$ to $+100^\circ\text{C}$ , VCC = 3.0V to 3.6V	-1		+1	$^\circ\text{C}$
	$T_R = 0^\circ\text{C}$ to $+125^\circ\text{C}$ (Note 2)	-3		+3	
Temperature Error, Local Diode	$T_A = +60^\circ\text{C}$ to $+100^\circ\text{C}$	-3		+3	$^\circ\text{C}$
	$T_A = 0^\circ\text{C}$ to $+85^\circ\text{C}$ (Note 2)	-5		+5	
Supply-Voltage Range		3.0		5.5	V
Undervoltage Lockout Threshold	VCC input, disables A/D conversion, rising edge		2.8		V
Undervoltage Lockout Hysteresis			50		mV
Power-On Reset Threshold	VCC, falling edge		1.7		V
POR Threshold Hysteresis			50		mV
Standby Supply Current	Logic inputs forced to VCC or GND	SMBus static		3	$\mu\text{A}$
		Hardware or software standby, SMBCLK at 10kHz		4	
Average Operating Supply Current	Auto-convert mode. Logic inputs forced to VCC or GND	0.5 conv/sec		35	$\mu\text{A}$
		8.0 conv/sec		320	
Conversion Time	From stop bit to conversion complete (both channels)		125		ms
Conversion Rate Timing	Conversion-Rate Control Byte=04h, 1Hz		1		sec
Remote-Diode Source Current	DXP forced to 1.5V	High level		176	$\mu\text{A}$
		Low level		11	

## ■ ELECTRICAL CHARACTERISTICS (cont.)

(VCC = + 3.3V, T<sub>A</sub> = 0 to +85°C, unless otherwise noted.)

PARAMETER	CONDITIONS	MIN	TYP	MAX	UNITS
SMBus Interface					
Logic Input High Voltage	$\overline{\text{STBY}}$ , SMBCLK, SMBDATA; V <sub>CC</sub> = 3V to 5.5V	2.4			V
Logic Input Low Voltage	$\overline{\text{STBY}}$ , SMBCLK, SMBDATA; V <sub>CC</sub> = 3V to 5.5V			0.8	V
Logic Output Low Sink Current	$\overline{\text{ALERT}}$ , SMBDATA forced to 0.4V	6			mA
$\overline{\text{ALERT}}$ Output High Leakage Current	$\overline{\text{ALERT}}$ forced to 5.5V			1	μA
Logic Input Current	Logic inputs forced to VCC or GND	-2		2	μA
SMBus Input Capacitance	SMBCLK, SMBDATA		5		pF
SMBus Clock Frequency				100	kHz
SMBus Timeout	SMBCLK low time for interface reset		30		ms
SMBCLK Clock Low Time	t <sub>LOW</sub> , 10% to 10% points	4.7			μs
SMBCLK Clock High Time	t <sub>HIGH</sub> , 90% to 90% points	4			μs
SMBus Start-Condition Setup Time		4.7			μs
SMBus Repeated Start-Condition Setup Time	t <sub>SU: STA</sub> , 90% to 90% points	500			ns
SMBus Start-Condition Hold Time	t <sub>HD: STA</sub> , 10% of SMBDATA to 90% of SMBCLK	4			μs
SMBus Stop-Condition Setup Time	t <sub>SD: STO</sub> , 90% of SMBCLK to 10% of SMBDATA	4			μs
SMBus Data Valid to SMBCLK Rising-Edge Time	t <sub>SU: DAT</sub> , 10% or 90% of SMBDATA to 10% of SMBCLK	800			ns
SMBus Data-Hold Time	t <sub>HD: DAT</sub>	300			ns
SMBCLK Falling Edge to SMBus Data-Valid Time	Master clocking in data			1	μs

**Note 1:** A remote diode is any diode-connected transistor from Table1. T<sub>R</sub> is the junction temperature of the remote of the remote diode. See Remote Diode Selection for remote diode forward voltage requirements.

**Note 2:** Guaranteed by design but not 100% tested.

## ■ PIN DESCRIPTIONS

PIN	NAME	FUNCTION
1	VCC	Supply Voltage Input, 3V to 5.5V. Bypass to GND with a 0.1μF capacitor.
2	DXP	Combined Current Source and A/D Positive Input for remote-diode channel. Do not leave DXP floating; tie DXP to DXN if no remote diode is used. Place a 2200pF capacitor between DXP and DXN for noise filtering.
3	DXN	Combined Current Sink and A/D Negative Input.
4	$\overline{\text{THERM}}$	Open-drain output. Requires pull-up to VCC.
5	GND	Ground
6	$\overline{\text{ALERT}}$	SMBus Alert (interrupt) Output, open drain
7	SMBDATA	SMBus Serial-Data Input / Output, open drain
8	SMBCLK	SMBus Serial-Clock Input

## ■ BLOCK DIAGRAM

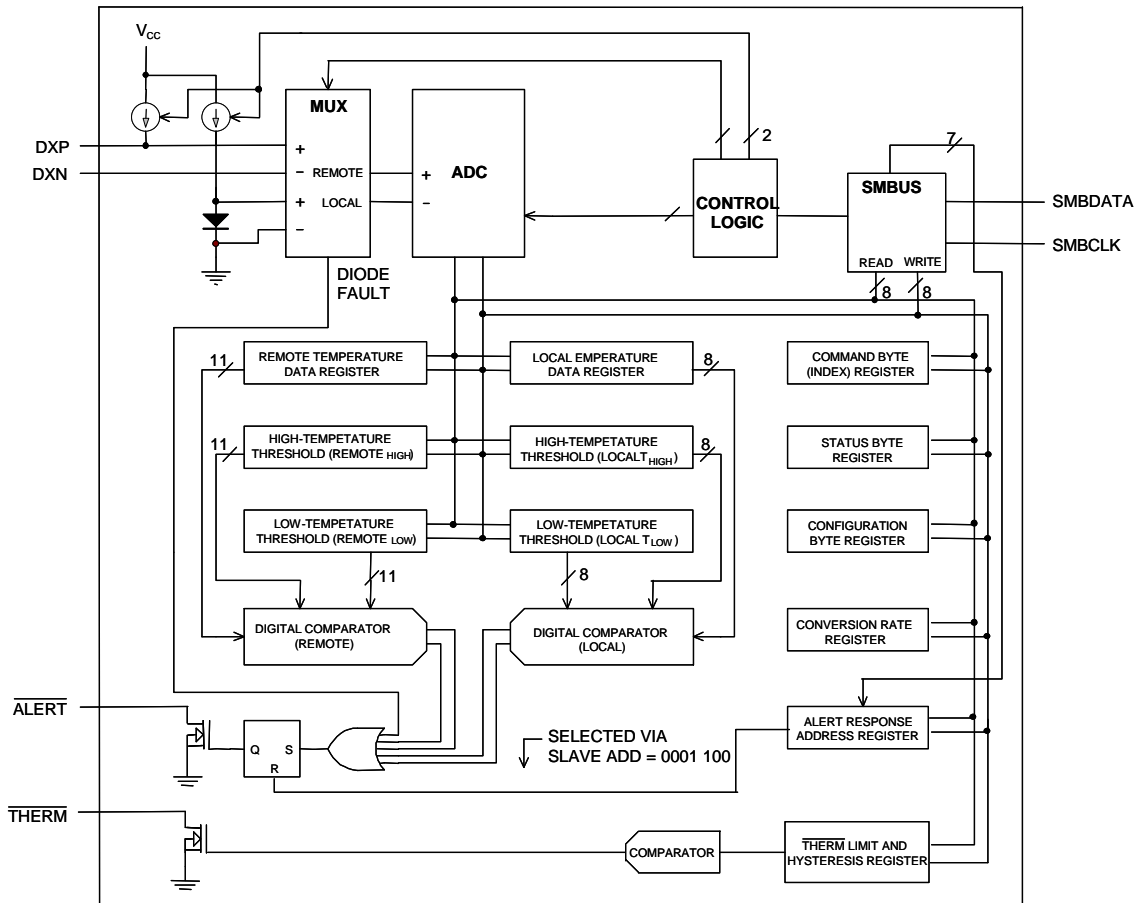

## ■ PIN CONFIGURATION

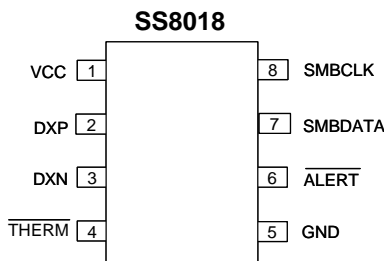

## ■ TYPICAL APPLICATION

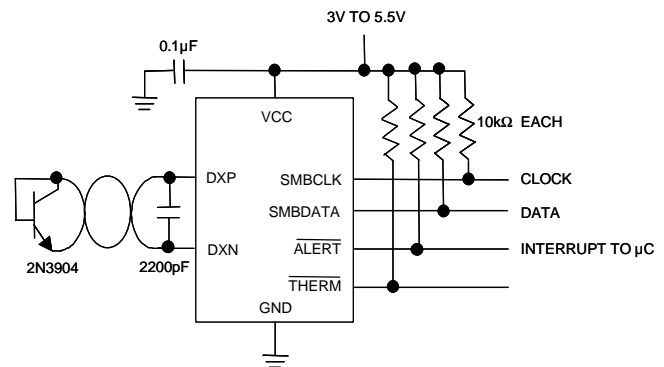

## APPLICATIONS INFORMATION

The SS8018 is a temperature sensor designed to work in conjunction with an external microcontroller ( $\mu\text{C}$ ) or other intelligence in thermostatic, process-control or monitoring applications. The  $\mu\text{C}$  is typically a power-management or keyboard controller, generating SMBus serial commands by “bit-banging” general-purpose input-output (GPIO) pins or via a dedicated SMBus interface block.

Essentially a serial analog-to-digital converter (ADC) with a sophisticated front end, the SS8018 contains a switched current source, a multiplexer, an ADC, an SMBus interface and associated control logic (Figure 1). Temperature data from the ADC is loaded into two data registers, where it is automatically compared with data previously stored in several over/under-temperature alarm registers.

### ADC and Multiplexer

The ADC is an averaging type that integrates over a 60ms period (each channel, typical), with excellent noise rejection.

The multiplexer automatically steers bias currents through the remote and local diodes, measures their forward voltages, and computes their temperatures. Both channels are automatically converted once the conversion process has started, either in free-running or single-shot mode. If one of the two channels is not used, the device still performs both measurements, and the user can simply ignore the results of the unused channel. If the remote diode channel is unused, tie DXP to DXN rather than leaving the pins open.

The worst-case DXP-DXN differential input voltage range is 0.25V to 0.95V.

Excess resistance in series with the remote diode causes about  $+0.6^\circ\text{C}$  error per ohm. Likewise,  $240\mu\text{V}$  of offset voltage forced on DXP-DXN causes about  $1^\circ\text{C}$  error.

### A/D Conversion Sequence

If a Start command is written (or generated automatically in the free-running auto-convert mode), both channels are converted, and the results of both measurements are available after the end of conversion. A BUSY status bit in the status byte shows that the device is actually performing a new conversion; however, even if the ADC is busy, the results of the previous conversion are always available.

### Remote Diode Selection

Temperature accuracy depends on having a good-quality, diode-connected small-signal transistor. The SS8018 can also directly measure the die temperature

of CPUs and other integrated circuits having on-board temperature-sensing diodes.

The transistor must be a small-signal type with a relatively high forward voltage; otherwise, the A/D input voltage range can be violated. The forward voltage must be greater than 0.25V at  $10\mu\text{A}$ ; check to ensure this is true at the highest expected temperature. The forward voltage must be less than 0.95V at  $300\mu\text{A}$ ; check to ensure this is true at the lowest expected temperature. Large power transistors don't work at all. Also, ensure that the base resistance is less than  $100\Omega$ . Tight specifications for forward-current gain (+50 to +150, for example) indicate that the manufacturer has good process controls and that the devices have consistent  $V_{be}$  characteristics.

**Table 1. Remote-Sensor Transistor Manufacturers**

MANUFACTURER	MODEL NUMBER
Philips	PMBS3904
Motorola(USA)	MMBT3904
National Semiconductor (USA)	MMBT3904

Note: Transistors must be diode-connected (base shorted to collector).

### Thermal Mass and Self-Heating

Thermal mass can seriously degrade the SS8018's effective accuracy. The thermal time constant of the SOP package is about 140 seconds in still air. For the SS8018 junction temperature to settle to within  $+1^\circ\text{C}$  after a sudden  $+100^\circ\text{C}$  change requires about five time constants or 12 minutes. The use of smaller packages for remote sensors, such as SOT23s, improves the situation. Take care to account for thermal gradients between the heat source and the sensor, and ensure that stray air currents across the sensor package do not interfere with measurement accuracy. Self-heating does not significantly affect measurement accuracy. Remote-sensor self-heating due to the diode current source is negligible. For the local diode, the worst-case error occurs when auto-converting at the fastest rate and simultaneously sinking maximum current at the  $\overline{\text{ALERT}}$  output. For example, at an 8Hz rate and with  $\overline{\text{ALERT}}$  sinking 1mA, the typical power dissipation is  $V_{CC} \times 320\mu\text{A}$  plus  $0.4\text{V} \times 1\text{mA}$ . Package R(J-A) is about  $120^\circ\text{C}/\text{W}$ , so with  $V_{CC} = 3.3\text{V}$  and no copper PC board heat-sinking, the resulting temperature rise is:

$$dT = 1.45\text{mW} \times 120^\circ\text{C}/\text{W} = 0.17^\circ\text{C}$$

Even with these contrived circumstances, it is difficult to introduce significant self-heating errors.

### ADC Noise Filtering

The ADC is an integrating type with inherently good noise rejection. Micro-power operation places constraints on high-frequency noise rejection; therefore, careful PC board layout and proper external noise filtering are required for high-accuracy remote measurements in electrically noisy environments.

High-frequency EMI is best filtered at DXP and DXN with an external 2200pF capacitor. This value can be increased to about 3300pF (max), including cable capacitance. Higher capacitance than 3300pF introduces errors due to the rise time of the switched current source.

Nearly all noise sources tested cause the ADC measurements to be higher than the actual temperature, typically by +1°C to 10°C, depending on the frequency and amplitude.

### PC Board Layout

Place the SS8018 as close as practical to the remote diode. In a noisy environment, such as a computer motherboard, this distance can be 4 in. to 8 in. (typical) or more as long as the worst noise sources (such as CRTs, clock generators, memory buses, and ISA/PCI buses) are avoided.

Do not route the DXP-DXN lines next to the deflection coils of a CRT. Also, do not route the traces across a fast memory bus, which can easily introduce +30°C error, even with good filtering; otherwise, most noise sources are fairly benign.

Route the DXP and DXN traces in parallel and in close proximity to each other, away from any high-voltage traces such as +12V<sub>DC</sub>. Leakage currents from PC board contamination must be dealt with carefully, since a 10MΩ leakage path from DXP to ground causes about +1°C error.

Connect guard traces to GND on either side of the DXP-DXN traces (Figure 2). With guard traces in place, routing near high-voltage traces is no longer an issue.

Route through as few vias and cross-unders as possible to minimize copper/solder thermocouple effects.

When introducing a thermocouple, make sure that both the DXP and the DXN paths have matching thermocouples. In general, PC board-induced thermocouples are not a serious problem. A copper-solder thermocouple exhibits 3μV/°C, and it takes about 240μV of voltage error at DXP-DXN to cause a +1°C measurement error. So, most parasitic thermocouple errors are swamped out.

Use wide traces. Narrow ones are more inductive and

tend to pick up radiated noise. The 10 mil widths and spacing recommended on Figure 2 aren't absolutely necessary (as they offer only a minor improvement in leakage and noise), but try to use them where practical.

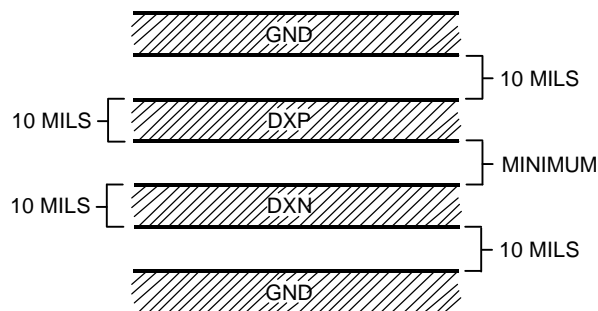

**Figure 2. Recommended DXP/DXN PC Traces**

Keep in mind that copper can't be used as an EMI shield, and only ferrous materials such as steel work will. Placing a copper ground plane between the DXP-DXN traces and traces carrying high-frequency noise signals does not help reduce EMI.

### PC Board Layout Checklist

- Place the SS8018 close to a remote diode.
- Keep traces away from high voltages (+12V bus).
- Keep traces away from fast data buses and CRTs.
- Use recommended trace widths and spacing.
- Place a ground plane under the traces
- Use guard traces flanking DXP and DXN and connecting to GND.
- Place the noise filter and the 0.1μF VCC bypass capacitors close to the SS8018.

### Twisted Pair and Shielded Cables

For remote-sensor distances longer than 8 in., or in particularly noisy environments, a twisted pair is recommended. Its practical length is 6 feet to 12feet (typical) before noise becomes a problem, as tested in a noisy electronics laboratory. For longer distances, the best solution is a shielded twisted pair like that used for audio microphones. Connect the twisted pair to DXP and DXN and the shield to GND, and leave the shield's remote end un-terminated.

Excess capacitance at DX limits practical remote sensor distances (see Typical Operating Characteristics). For very long cable runs, the cable's parasitic capacitance often provides noise filtering, so the 2200pF capacitor can often be removed or reduced in value. Cable resistance also affects remote-sensor accuracy; 1Ω series resistance introduces about + 0.6°C error.

### Low-Power Standby Mode

Standby mode disables the ADC and reduces the supply-current drain to about 10µA. Enter standby mode by forcing high to the  $\overline{\text{RUN/STOP}}$  bit in the configuration byte register. Software standby mode behaves such that all data is retained in memory, and the SMB interface is alive and listening for reads and writes.

Software standby mode is not a shutdown mode. With activity on the SMBus, extra supply current is drawn (see Typical Operating Characteristics). In software standby mode, the G781 can be forced to perform A/D conversions via the one-shot command, despite the  $\overline{\text{RUN/STOP}}$  bit being high. If software standby command is received while a conversion is in progress, the conversion cycle is truncated, and the data from that conversion is not latched into either temperature reading register. The previous data is not changed and remains available.

Supply-current drain during the 125ms conversion period is always about 320µA. Slowing down the conversion rate reduces the average supply current (see Typical Operating Characteristics). In between conversions, the instantaneous supply current is about 25µA due to the current consumed by the conversion rate timer. In standby mode, supply current drops to about 3µA. At very low supply voltages (under the power-on-reset threshold), the supply current is higher due to the address pin bias currents. It can be as high as 100µA, depending on ADD0 and ADD1 settings.

### SMBus Digital Interface

From a software perspective, the SS8018 appears as a set of byte-wide registers that contain temperature data, alarm threshold values, or control bits. A standard SMBus 2-wire serial interface is used to read temperature data and write control bits and alarm threshold data. Each A/D channel within the device responds to the same SMBus slave address for normal reads and writes.

The SS8018 employs four standard SMBus protocols: Write Byte, Read Byte, Send Byte, and Receive Byte (Figure 3). The shorter Receive Byte protocol allows quicker transfers, provided that the correct data register was previously selected by a Read Byte instruction. Use caution with the shorter protocols in multi-master systems, since a second master could overwrite the com-

mand byte without informing the first master.

The temperature data format is 11bits plus sign in twos-complement form for remote channel, with each data bit representing 0.125°C (Table 2, Table 3), transmitted MSB first.

**Table 2. Temperature Data Format (Two's-Complement)**

TEMP. (°C)	DIGITAL OUTPUT			
	DATA BITS			
	SIGN	MSB	LSB	EXT
+127.875	0	111	1111	111
+126.375	0	111	1110	011
+25.5	0	001	1001	100
+1.75	0	000	0001	110
+0.5	0	000	0000	100
+0.125	0	000	0000	001
-0.125	1	111	1111	111
-1.125	1	111	1110	111
-25.5	1	110	0110	100
-55.25	1	100	1000	110
-65.000	1	011	1111	000

**Table 3. Extended Temperature Data Format**

EXTENDED RESOLUTION	DATA BITS
0.000°C	0000 0000
0.125°C	0010 0000
0.250°C	0100 0000
0.375°C	0110 0000
0.500°C	1000 0000
0.625°C	1010 0000
0.750°C	1100 0000
0.875°C	1110 0000

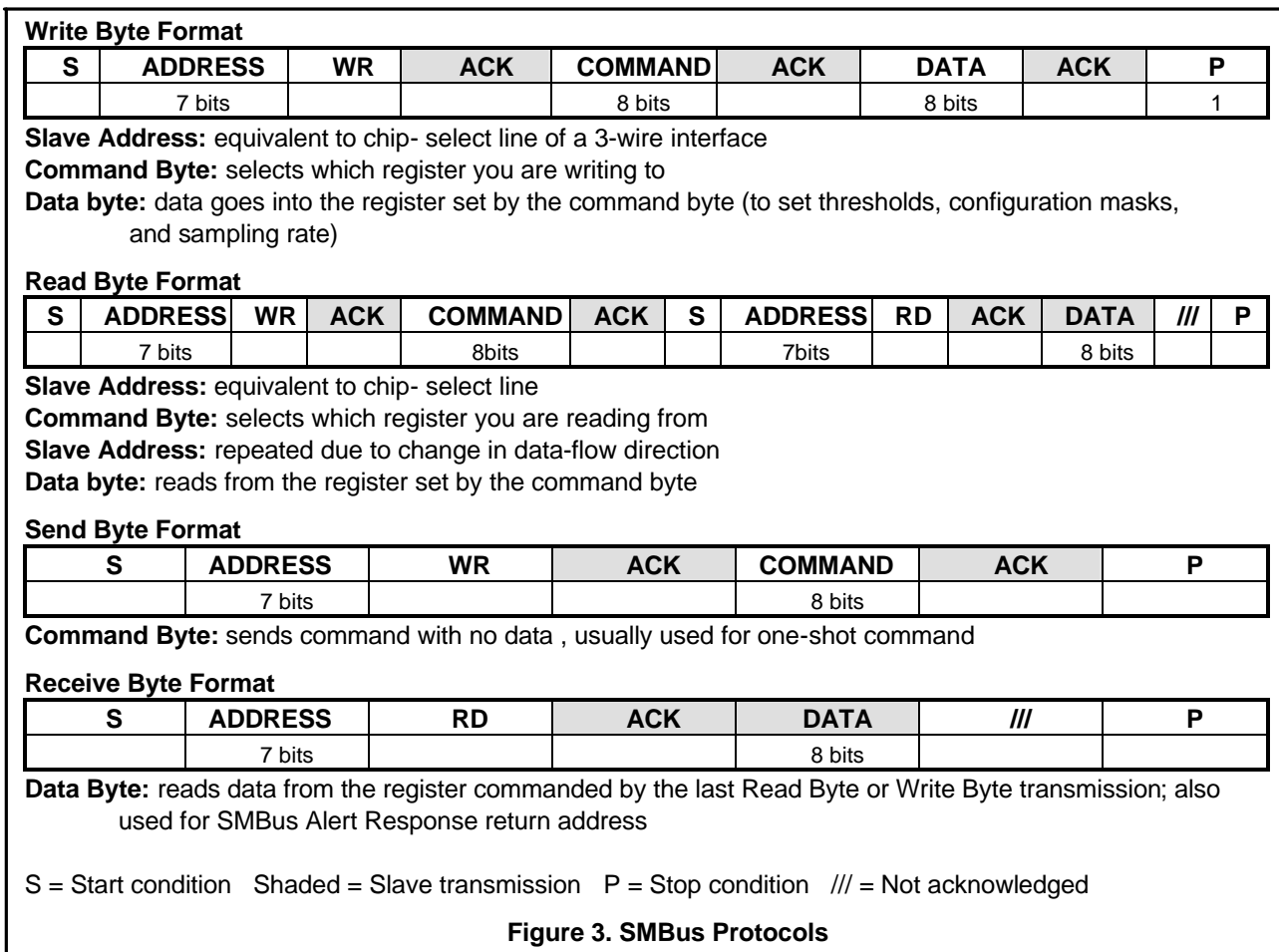



**Slave Address**

The SS8018 appears to the SMBus as one device having a common address for both ADC channels. The SS8018 device address is set to 1001100.

The SS8018 also responds to the SMBus Alert Response slave address (see the Alert Response Address section).

**One-Shot Register**

The One-shot register is to initiate a single conversion and comparison cycle when the device is in standby mode and auto conversion mode. The write operation to this register causes one-shot conversion and the data written to it is irrelevant and is not stored.

**Serial Bus Interface Reinitialization**

When SMBCLK is held low for more than 30ms (typical) during an SMBus communication, the SS8018 will reinitiate its bus interface and be ready for a new transmission.

**Alarm Threshold Registers**

Four registers store alarm threshold data, with high-temperature ( $T_{HIGH}$ ) and low-temperature ( $T_{LOW}$ ) registers for each A/D channel. If either measured temperature equals or exceeds the corresponding alarm threshold value, an  $\overline{ALERT}$  interrupt is asserted.

The power-on-reset (POR) state of both  $T_{HIGH}$  registers is full scale (01010101, or +85°C). The POR state of both  $T_{LOW}$  registers is 0°C.

**Diode Fault Alarm**

There is a fault detector at DXP that detects whether the remote diode has an open-circuit condition. At the beginning of each conversion, the diode fault is checked, and the status byte is updated. This fault detector is a simple voltage detector. If DXP rises above  $VCC - 1V$  (typical) due to the diode current source, a fault is detected and the device alarms through pulling  $\overline{ALERT}$  low while the remote temperature reading doesn't update in this condition. Note that the diode fault isn't checked until a conversion is initiated, so immediately after power-on reset the status byte indicates no fault is present, even if the diode path is broken.

If the remote channel is shorted (DXP to DXN or DXP to GND), the ADC reads 1000 0000(-128°C) so as not to trip either the  $T_{HIGH}$  or  $T_{LOW}$  alarms at their POR settings.

 **$\overline{ALERT}$  Interrupts**

The  $\overline{ALERT}$  interrupt output signal is latched and can only be cleared by reading the Alert Response address. Interrupts are generated in response to  $T_{HIGH}$  and  $T_{LOW}$  comparisons and when the remote diode is disconnected (for fault detection). The interrupt does not halt automatic conversions; new temperature data continues to be available over the SMBus interface after  $\overline{ALERT}$  is asserted. The interrupt output pin is open-drain so that devices can share a common interrupt line. The interrupt rate can never exceed the conversion rate.

The interface responds to the SMBus Alert Response address, an interrupt pointer return-address feature (see Alert Response Address section). Prior to taking corrective action, always check to ensure that an interrupt is valid by reading the current temperature.

**Alert Response Address**

The SMBus Alert Response interrupt pointer provides quick fault identification for simple slave devices that lack the complex, expensive logic needed to be a bus master. Upon receiving an  $\overline{ALERT}$  interrupt signal, the host master can broadcast a Receive Byte transmission to the Alert Response slave address (0001 100). Then any slave device that generated an interrupt attempts to identify itself by putting its own address on the bus (Table 4).

The Alert Response can activate several different slave devices simultaneously, similar to the SMBus General Call. If more than one slave attempts to respond, bus arbitration rules apply, and the device with the lower address code wins. The losing device does not generate an acknowledge and continues to hold the  $\overline{ALERT}$  line low until serviced (implies that the host interrupt input is level-sensitive). Successful reading of the alert response address clears the interrupt latch.

**Table 4. Read Format for Alert Response Address (0001 100)**

BIT	NAME
7(MSB)	ADD7
6	ADD6
5	ADD5
4	ADD4
3	ADD3
2	ADD2
1	ADD1
0(LSB)	1

### Command Byte Functions

The 8-bit command byte register (Table 5) is the master index that points to the various other registers within the SS8018. The register's POR state is 0000 0000, so that a Receive Byte transmission (a protocol that lacks the command byte) that occurs immediately after POR returns the current local temperature data.

The one-shot command immediately forces a new conversion cycle to begin. In software standby mode ( $\overline{\text{RUN/STOP}}$  bit = high), a new conversion is begun, after which the device returns to standby mode. If a conversion is in progress when a one-shot command is received in auto-convert mode ( $\overline{\text{RUN/STOP}}$  bit = low) between conversions, a new conversion begins, the conversion rate timer is reset, and the next automatic conversion takes place after a full delay elapses.

### Configuration Byte Functions

The configuration byte register (Table 6) is used to mask interrupts and to put the device in software standby mode. The other bits are empty.

### Status Byte Functions

The status byte register (Table 7) indicates which (if any) temperature thresholds have been exceeded. This byte also indicates whether or not the ADC is converting and whether there is an open circuit in the remote diode DXP-DXN path. After POR, the normal state of all the flag bits is zero, assuming none of the alarm conditions are present. The status byte is cleared by any successful read of the status, unless the fault persists. Note that the  $\overline{\text{ALERT}}$  interrupt latch is not automatically cleared when the status flag bit is cleared.

When reading the status byte, you must check for internal bus collisions caused by asynchronous ADC timing, or else disable the ADC prior to reading the status byte (via the  $\overline{\text{RUN/STOP}}$  bit in the configuration byte). In one-shot mode, read the status byte only after the conversion is complete, which is approximately 125ms max after the one-shot conversion is commanded.

**Table 5. Command-Byte Bit Assignments**

REGISTER	COMMAND	POR STATE	FUNCTION
RLTS	00h	0000 0000*	Read local temperature. It returns latest temperature
RRTE	01h	0000 0000*	Read remote temperature. It returns latest temperature
RSL	02h	N/A	Read status byte (flags, busy signal)
RCL	03h	0000 0000	Read configuration byte
RCRA	04h	0000 1000	Read conversion rate byte
RLHN	05h	0101 0101 (85)	Read local $T_{\text{HIGH}}$ limit
RLLI	06h	0000 0000	Read local $T_{\text{LOW}}$ limit
RRHI	07h	0101 0101 (85)	Read remote $T_{\text{HIGH}}$ limit
RRLS	08h	0000 0000	Read remote $T_{\text{LOW}}$ limit
WCA	09h	N/A	Write configuration byte
WCRW	0Ah	N/A	Write conversion rate byte
WLHO	0Bh	N/A	Write local $T_{\text{HIGH}}$ limit
WLLM	0Ch	N/A	Write local $T_{\text{LOW}}$ limit
WRHA	0Dh	N/A	Write remote $T_{\text{HIGH}}$ limit
WRLN	0Eh	N/A	Write remote $T_{\text{LOW}}$ limit
OSHT	0Fh	N/A	One-shot command (use send-byte format)
RTEXT	10h	0	Remote temperature extended byte
RTOFS	11h	0	Remote temperature offset high byte
RTOFSEXT	12h	0	Remote temperature offset extended byte
RLEXT	13h	0	Remote $T_{\text{HIGH}}$ limit extended byte
RHEXT	14h	0	Remote $T_{\text{LOW}}$ limit extended byte
RTTHERM	19h	0101 0101 (85)	Remote temperature $\overline{\text{THERM}}$ limit
LTHERM	20h	0101 0101 (85)	Local temperature $\overline{\text{THERM}}$ limit
THERMHYST	21h	0000 1010 (10)	$\overline{\text{THERM}}$ hysteresis
ALERTFQ	22h	0	$\overline{\text{ALERT}}$ fault queue code
MFGIO	FEh	0100 0111	Manufacturer ID
DEVID	FFh	0000 0001	Device ID

\*If the device is in standby mode at POR, both temperature registers read 0°C.

**Table 6. Configuration-Byte Bit Assignments**

BIT	NAME	POR STATE	FUNCTION
7 (MSB)	MASK	0	Masks all $\overline{\text{ALERT}}$ interrupts when high.
6	$\overline{\text{RUN/STOP}}$	0	Standby mode control bit. If high, the device immediately stops converting and enters standby mode. If low, the device converts in either one-shot or timer mode.
5-0	RFU	0	Reserved for future use

**Table 7. Status-Byte Bit Assignments**

BIT	NAME	FUNCTION
7 (MSB)	BUSY	A high indicates that the ADC is busy converting.
6	LHIGH*	A high indicates that the local high-temperature alarm has activated.
5	LLOW*	A high indicates that the local low-temperature alarm has activated.
4	RHIGH*	A high indicates that the remote high-temperature alarm has activated.
3	RLOW*	A high indicates that the remote low-temperature alarm has activated.
2	OPEN*	A high indicates a remote-diode continuity (open-circuit) fault.
1	RTHRM	A high indicates a remote temperature $\overline{\text{THERM}}$ alarm has activated.
0 (LSB)	LTHRM	A high indicates a local temperature $\overline{\text{THERM}}$ alarm has activated.

\*These flags stay high until cleared by POR, or until the status byte register is read.

**Table 8. Conversion-Rate Control Byte**

DATA	CONVERSION RATE (Hz)
00h	0.0625
01h	0.125
02h	0.25
03h	0.5
04h	1
05h	2
06h	4
07h	8
08h	16
09h to FFh	RFU

To check for internal bus collisions, read the status byte. If the least significant seven bits are ones, discard the data and read the status byte again. The status bits LHIGH, LLOW, RHIGH, and RLOW are refreshed on the SMBus clock edge immediately following the stop condition, so there is no danger of losing temperature-related status data as a result of an internal bus collision. The OPEN status bit (diode continuity fault) is only refreshed at the beginning of a conversion, so OPEN data is lost. The  $\overline{\text{ALERT}}$  interrupt latch is independent of the status byte register, so no false alerts are generated by an internal bus collision.

When auto-converting, if the THIGH and TLOW limits are close together, it's possible for both high-temp and low-temp status bits to be set, depending on the amount of time between status read operations (especially when converting at the fastest rate). In these circumstances, it's best not to rely on the status bits to indicate reversals in long-term temperature changes and instead use a current temperature reading to establish the trend direction.

For bit 1 and bit 0, a high indicates a temperature alarm happened for remote and local diode respectively. The  $\overline{\text{THERM}}$  pin also asserts. These two bits wouldn't be cleared when reading status byte.

#### Conversion Rate Byte

The conversion rate register (Table 8) programs the time interval between conversions in free-running auto-convert mode. This variable rate control reduces the supply current in portable-equipment applications. The conversion rate byte's POR state is 08h (16Hz). The SS8018 looks only at the 4 LSB bits of this register, so the upper 4 bits are "don't care" bits, which should be set to zero. The conversion rate tolerance is  $\pm 25\%$  at any rate setting.

Valid A/D conversion results for both channels are available one total conversion time (125ms, typical) after initiating a conversion, whether conversion is initiated via the  $\overline{\text{RUN/STOP}}$  bit, one-shot command, or initial power-up.

**POR AND UVLO**

The SS8018 has a volatile memory. To prevent ambiguous power-supply conditions from corrupting the data in memory and causing erratic behavior, a POR voltage detector monitors VCC and clears the memory if VCC falls below 1.7V (typical, see Electrical Characteristics table). When power is first applied and VCC rises above 1.7V (typical), the logic blocks begin operating, although reads and writes at VCC levels below 3V are not recommended. A second VCC comparator, the ADC UVLO comparator, prevents the ADC from converting until there is sufficient headroom (VCC= 2.8V typical).

**ALERT Fault Queue**

To suppress unwanted ALERT triggering the G781 embedded a fault queue function. The ALERT won't assert until consecutive out of limit measurements have reached the queue number. The mapping of fault queue register (ALERTFQ, 22h) value to fault queue number is shown in the Table 9.

**Table 9. Alert Fault Queue**

ALERTFQ VALUE	FAULT QUEUE NUMBER
XXXX000X	1
XXXX001X	2
XXXX010X	3
XXXX011X	3
XXXX100X	4
XXXX101X	4
XXXX110X	4
XXXX111X	4

**Operation of The THERM Function**

A local and remote THERM limit can be programmed into the SS8018 to set the temperature limit above which the THERM pin asserts low and the bit 1, of status byte will be set to 1 corresponding to remote and local over temperature. These two bits won't be cleared to 0 by reading status byte if the over temperature condition remain. A hysteresis value is provided by writing the register 21h to set the temperature threshold to release the THERM pin alarm state, The releasing temperature is the value of register 19h, 20h minus the value in register 21h. The format of register 21h is 2's complement. The THERM signal is open drain and requires a pull-up resistor to power supply.

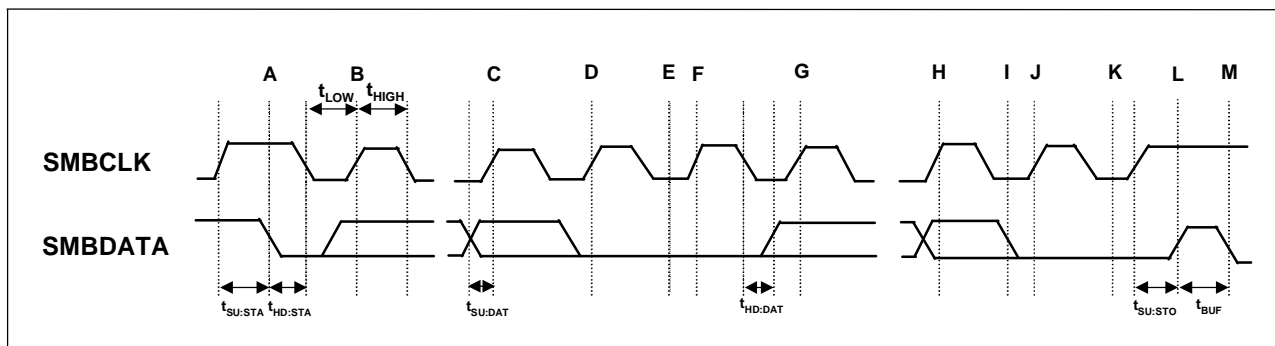
**Figure 4. SMBus Write Timing Diagram**

- |   |   |
|---|---|
| A = start condition                     | H = LSB of data clocked into slave        |
| B = MSB of address clocked into slave   | I = slave pulls SMBDATA line low          |
| C = LSB of address clocked into slave   | J = acknowledge clocked into master       |
| D = R/W bit clocked into slave          | K = acknowledge clocked pulse             |
| E = slave pulls SMBDATA line low        | L = stop condition data executed by slave |
| F = acknowledge bit clocked into master | M = new start condition                   |
| G = MSB of data clocked into slave      |   |

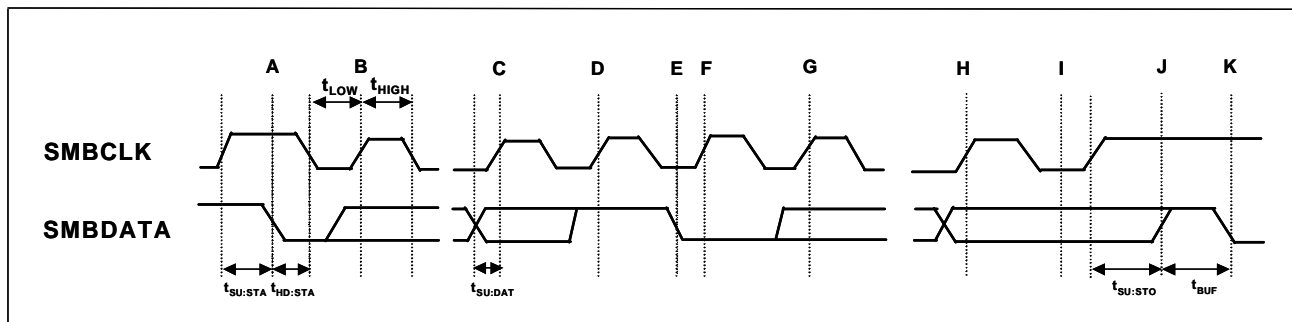
**Figure 5. SMBus Read Timing Diagram**

- |   |                                     |
|---|-------------------------------------|
| A = start condition                     | G = MSB of data clocked into master |
| B = MSB of address clocked into slave   | H = LSB of data clocked into master |
| C = LSB of address clocked into slave   | I = acknowledge clocked pulse       |
| D = R/W bit clocked into slave          | J = stop condition                  |
| E = slave pulls SMBDATA line low        | K = new start condition             |
| F = acknowledge bit clocked into master |                                     |

## ■ PHYSICAL DIMENSIONS

### 8 Pin SOP Package

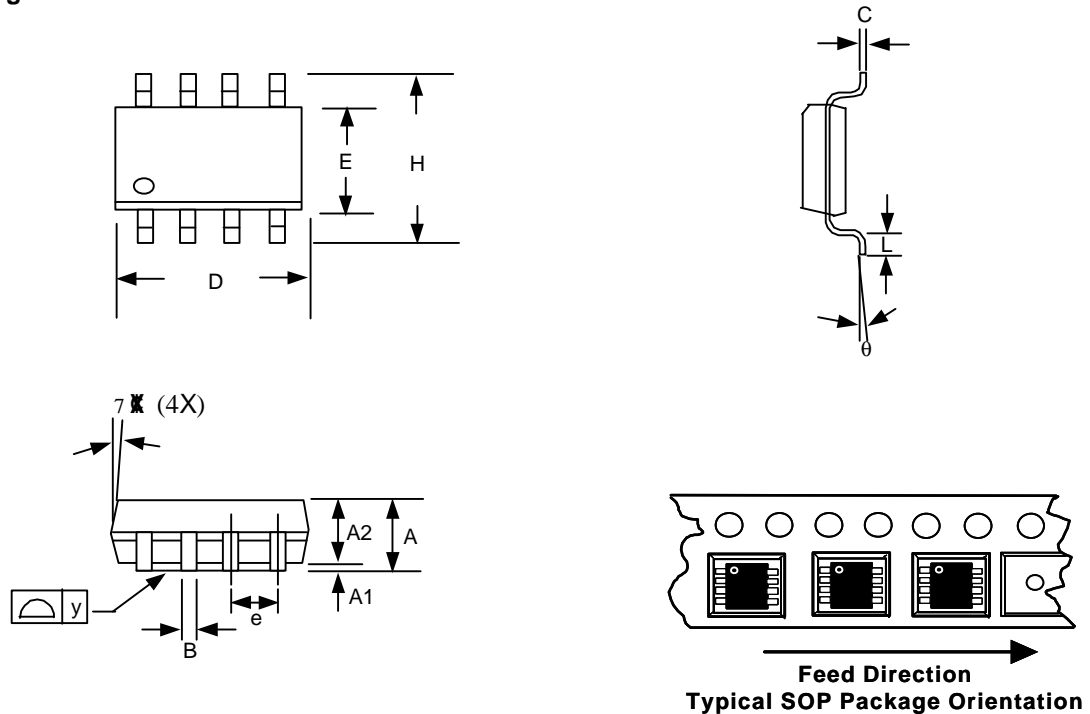

**Note:**

1. Package body sizes exclude mold flash and gate burrs
2. Dimension L is measured in gage plane
3. Tolerance 0.10mm unless otherwise specified
4. Controlling dimension is millimeter converted inch dimensions are not necessarily exact.

SYMBOL	DIMENSION IN MM			DIMENSION IN INCH		
	MIN.	NOM.	MAX.	MIN.	NOM.	MAX.
A	1.35	1.60	1.75	0.053	0.063	0.069
A1	0.10	-----	0.25	0.004	-----	0.010
A2	-----	1.45	-----	-----	0.057	-----
B	0.33	-----	0.51	0.013	-----	0.020
C	0.19	-----	0.25	0.007	-----	0.010
D	4.80	-----	5.00	0.189	-----	0.197
E	3.80	-----	4.00	0.150	-----	0.157
e	-----	1.27	-----	-----	0.050	-----
H	5.80	-----	6.20	0.228	-----	0.244
L	0.40	-----	1.27	0.016	-----	0.050
y	-----	-----	0.10	-----	-----	0.004
?	0°	-----	8°	0°	-----	8°

Information furnished by Silicon Standard Corporation is believed to be accurate and reliable. However, Silicon Standard Corporation makes no guarantee or warranty, express or implied, as to the reliability, accuracy, timeliness or completeness of such information and assumes no responsibility for its use, or for infringement of any patent or other intellectual property rights of third parties that may result from its use. Silicon Standard reserves the right to make changes as it deems necessary to any products described herein for any reason, including without limitation enhancement in reliability, functionality or design. No license is granted, whether expressly or by implication, in relation to the use of any products described herein or to the use of any information provided herein, under any patent or other intellectual property rights of Silicon Standard Corporation or any third parties.