

Recommended P.C.B Layout

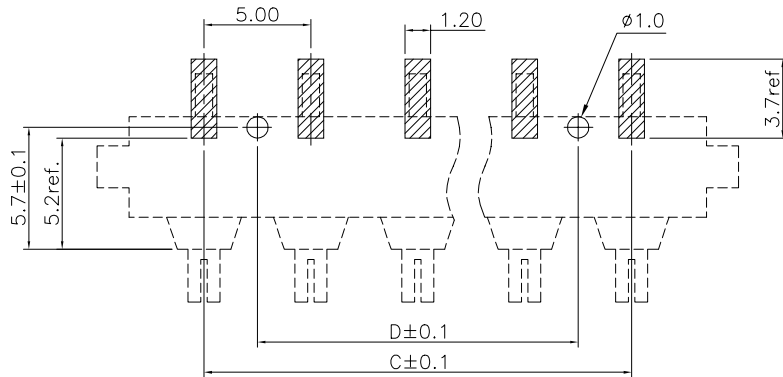

Dimensional Information

SUYIN P/NO.	SUYIN P/NO.(OLD.)	DIM.A	DIM.B	DIM.C	DIM.D
505110MB002XX00ZU	5010A-02GXX	15.0	12.0	5.0	
505110MB003XX00ZU	5010A-03GXX	20.0	17.0	10.0	5.0
505110MB004XX00ZU	5010A-04GXX	25.0	22.0	15.0	10.0
505110MB005XX00ZU	5010A-05GXX	30.0	27.0	20.0	15.0
505110MB006XX00ZU	5010A-06GXX	35.0	32.0	25.0	20.0
505110MB007XX00ZU	5010A-07GXX	40.0	37.0	30.0	25.0
505110MB008XX00ZU	5010A-08GXX	45.0	42.0	35.0	30.0
505110MB009XX00ZU	5010A-09GXX	50.0	47.0	40.0	35.0
505110MB010XX00ZU	5010A-10GXX	55.0	52.0	45.0	40.0

NOTE(I):

505110MB□□□□□□00ZU
1 2

- No. of pins.
- Plating
 - 'G1,-05u" gold over nickel.
 - 'G2,-Indicate gold flash.
 - 'G3,-10u" gold over nickel.
 - 'G4,-15u" gold over nickel.
 - 'G5,-30u" gold over nickel.
 - 'S1,-05u" Min. gold in contact area/
100u" Min. Tin in solder area.
 - 'S2,-Gold flash in contact area/
100u" Min. Tin in solder area.
 - 'S3,-10u" Min. gold in contact area/
100u" Min. Tin in solder area.
 - 'S4,-15u" Min. gold in contact area/
100u" Min. Tin in solder area.
 - 'S5,-30u" Min. gold in contact area/
100u" Min. Tin in solder area.

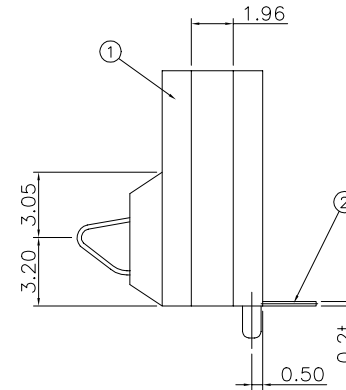

NO.	DESCRIPTION	MATERIAL	COLOR	REMARK
2	Terminal	Pho. Bronze		
1	Plastics	NY-6T	BLACK	UL94V-0

SUYIN
CONNECTOR

CUSTOMER COPY TITLE: BATTERY CONN. SPRING S.M.T TYPE

ECN (DCN) NO.	REV	DATE	DESCRIPTION	CHANGE	APPRO.	GENERAL TOLERANCE UNLESS OTHERWISE NOTED	ANGLE	DRAW	DESIGN	CHECK	APPRO.	PART NO.	PART NO. (OLD)	DRAWING NO.	SCALE	UNIT	mm	A4
							Angle ±2°		吳韋嘉	陳清照	宋權哲	505110MBXXXXX00ZU	5010A-XXGXX	505110MBXXXXX00ZU	4:1	mm		
	A		A1: 增加新料號; A2: 增加電鍍規格;			30 ~ 30 ±0.50			吳韋嘉	陳清照	宋權哲							
	0	98/06/25	NEW			10 ~ 10 ±0.30												
						~ 10 ±0.15												