

### FEATURES

- 13- or 16-bit user selectable temperature-to-digital converter
- Temperature accuracy: ±0.5°C from -40°C to +105°C
- No temperature calibration/correction required by user
- Power saving 1 sample per second (SPS) mode
- Fast first conversion on power-up of 6 ms
- I<sup>2</sup>C-compatible interface
- Operating temperature: -55°C to +150°C
- Operating voltage: 2.7 V to 5.5 V
- Critical overtemperature indicator
- Programmable overtemperature/undertemperature interrupt
- Low power consumption: 700 μW typical at 3.3 V
- Shutdown mode for lower power: 7 μW typical at 3.3 V
- 8-lead narrow SOIC RoHS-compliant package

### APPLICATIONS

- Medical equipment
- Environmental control systems
- Computer thermal monitoring
- Thermal protection
- Industrial process control
- Power system monitors
- Hand-held applications

### GENERAL DESCRIPTION

The ADT7410 is a high accuracy digital temperature sensor in a narrow SOIC package. It contains a band gap temperature reference and a 13 bit ADC to monitor and digitize the temperature to a 0.0625°C resolution. The ADC resolution, by default, is set to 13 bits (0.0625°C). This can be changed to 16 bits (0.0078°C) by setting Bit 7 in the configuration register (Register Address 0x03).

The ADT7410 is guaranteed to operate over supply voltages from 2.7 V to 5.5 V. Operating at 3.3 V, the average supply current is typically 210 μA. The ADT7410 has a shutdown mode that powers down the device and offers a shutdown current of typically 2 μA. The ADT7410 is rated for operation over the -55°C to +150°C temperature range.

Pin A0 and Pin A1 are available for address selection, giving the ADT7410 four possible I<sup>2</sup>C® addresses. The CT pin is an open-drain output that becomes active when the temperature exceeds a programmable critical temperature limit. The default critical temperature limit is 147°C. The INT pin is also an open-drain output that becomes active when the temperature exceeds a programmable limit. The INT and CT pins can operate in either comparator or interrupt mode.

### FUNCTIONAL BLOCK DIAGRAM

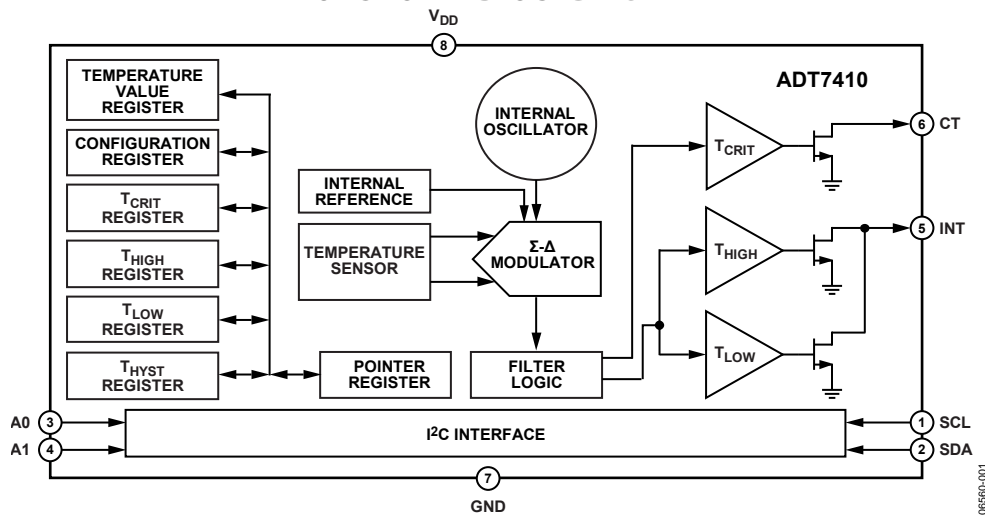

Figure 1.

#### Rev. 0

Information furnished by Analog Devices is believed to be accurate and reliable. However, no responsibility is assumed by Analog Devices for its use, nor for any infringements of patents or other rights of third parties that may result from its use. Specifications subject to change without notice. No license is granted by implication or otherwise under any patent or patent rights of Analog Devices. Trademarks and registered trademarks are the property of their respective owners.

**TABLE OF CONTENTS**

Features .....	1	Temperature Value Registers .....	13
Applications.....	1	Status Register.....	14
General Description .....	1	Configuration Register .....	14
Functional Block Diagram .....	1	T <sub>HIGH</sub> Setpoint Registers.....	15
Revision History .....	2	T <sub>LOW</sub> Setpoint Registers.....	15
Specifications.....	3	T <sub>CRIT</sub> Setpoint Registers.....	15
I <sup>2</sup> C Timing Specifications.....	4	T <sub>HYST</sub> Setpoint Register.....	16
Absolute Maximum Ratings.....	5	ID Register.....	16
ESD Caution.....	5	Serial Interface .....	17
Pin Configuration and Function Descriptions.....	6	Serial Bus Address.....	17
Typical Performance Characteristics .....	7	Writing Data .....	18
Theory of Operation .....	9	Reading Data.....	19
Circuit Information.....	9	Reset .....	19
Converter Details.....	9	General Call .....	19
Temperature Measurement .....	9	INT and CT Outputs.....	21
One-Shot Mode .....	10	Undertemperature and Overtemperature Detection .....	21
1 SPS Mode.....	10	Applications Information .....	23
Shutdown.....	11	Thermal Response Time .....	23
Fault Queue .....	11	Supply Decoupling .....	23
Temperature Data Format .....	12	Temperature Monitoring.....	23
Temperature Conversion Formulas .....	12	Outline Dimensions .....	24
Registers .....	13	Ordering Guide .....	24
Address Pointer Register .....	13		

**REVISION HISTORY****4/09—Revision 0: Initial Version**

## SPECIFICATIONS

$T_A = -55^{\circ}\text{C}$  to  $+150^{\circ}\text{C}$ ,  $V_{DD} = 2.7\text{ V}$  to  $5.5\text{ V}$ , unless otherwise noted.

Table 1.

Parameter	Min	Typ	Max	Unit	Test Conditions/Comments
TEMPERATURE SENSOR AND ADC					
Accuracy <sup>1</sup>			$\pm 0.5$	$^{\circ}\text{C}$	$T_A = -40^{\circ}\text{C}$ to $+105^{\circ}\text{C}$ , $V_{DD} = 2.7\text{ V}$ to $3.6\text{ V}$
			$\pm 0.7$	$^{\circ}\text{C}$	$T_A = -55^{\circ}\text{C}$ to $+150^{\circ}\text{C}$ , $V_{DD} = 2.7\text{ V}$ to $3.6\text{ V}$
			$\pm 0.8$	$^{\circ}\text{C}$	$T_A = -40^{\circ}\text{C}$ to $+105^{\circ}\text{C}$ , $V_{DD} = 4.5\text{ V}$ to $5.5\text{ V}$
			$\pm 1.0$	$^{\circ}\text{C}$	$T_A = -55^{\circ}\text{C}$ to $+150^{\circ}\text{C}$ , $V_{DD} = 2.7\text{ V}$ to $5.5\text{ V}$
ADC Resolution		13		Bits	Twos complement temperature value of the sign bit plus 12 ADC bits (power-up default resolution)
		16		Bits	Twos complement temperature value of the sign bit plus 15 ADC bits (Bit 7 = 1 in the configuration register)
Temperature Resolution					
13-Bit		0.0625		$^{\circ}\text{C}$	13-bit resolution (sign + 12-bit)
16-Bit		0.0078		$^{\circ}\text{C}$	16-bit resolution (sign + 15-bit)
Temperature Conversion Time		240		ms	Continuous conversion and one-shot conversion modes
Fast Temperature Conversion Time		6		ms	First conversion on power-up only
1 SPS Conversion Time		60		ms	Conversion time for 1 SPS mode
Temperature Hysteresis		0.02		$^{\circ}\text{C}$	Temperature cycle = $25^{\circ}\text{C}$ to $125^{\circ}\text{C}$ and back to $25^{\circ}\text{C}$
Repeatability		0.01		$^{\circ}\text{C}$	$T_A = 25^{\circ}\text{C}$
DC PSRR		0.1		$^{\circ}\text{C}/\text{V}$	$T_A = 25^{\circ}\text{C}$
DIGITAL OUTPUTS (OPEN DRAIN)					
High Output Leakage Current, $I_{OH}$		0.1	5	$\mu\text{A}$	CT and INT pins pulled up to $5.5\text{ V}$
Output High Current			1	mA	$V_{OH} = 5.5\text{ V}$
Output Low Voltage, $V_{OL}$			0.4	V	$I_{OL} = 2\text{ mA}$ @ $5.5\text{ V}$ , $I_{OL} = 1\text{ mA}$ @ $3.3\text{ V}$
Output High Voltage, $V_{OH}$	$0.7 \times V_{DD}$			V	
Output Capacitance, $C_{OUT}$		3		pF	
DIGITAL INPUTS					
Input Current			$\pm 1$	$\mu\text{A}$	$V_{IN} = 0\text{ V}$ to $V_{DD}$
Input Low Voltage, $V_{IL}$			0.4	V	
Input High Voltage, $V_{IH}$	$0.7 \times V_{DD}$			V	
SCL, SDA Glitch Rejection		50		ns	Input filtering suppresses noise spikes of less than 50 ns
Pin Capacitance		5	10	pF	
POWER REQUIREMENTS					
Supply Voltage	2.7		5.5	V	
Supply Current					
At $3.3\text{ V}$		210	250	$\mu\text{A}$	Peak current while converting, I <sup>2</sup> C interface inactive
At $5.5\text{ V}$		230	300	$\mu\text{A}$	Peak current while converting, I <sup>2</sup> C interface inactive
1 SPS Current					
At $3.3\text{ V}$		46		$\mu\text{A}$	$V_{DD} = 3.3\text{ V}$ , 1 SPS mode, $T_A = 25^{\circ}\text{C}$
At $5.5\text{ V}$		65		$\mu\text{A}$	$V_{DD} = 5.5\text{ V}$ , 1 SPS mode, $T_A = 25^{\circ}\text{C}$
Shutdown Current					
At $3.3\text{ V}$		2.0	15	$\mu\text{A}$	Supply current in shutdown mode
At $5.5\text{ V}$		4.4	25	$\mu\text{A}$	Supply current in shutdown mode
Power Dissipation Normal Mode		700		$\mu\text{W}$	$V_{DD} = 3.3\text{ V}$ , normal mode at $25^{\circ}\text{C}$
Power Dissipation 1 SPS		150		$\mu\text{W}$	Power dissipated for $V_{DD} = 3.3\text{ V}$ , $T_A = 25^{\circ}\text{C}$

<sup>1</sup> Accuracy includes lifetime drift.

# ADT7410

## I<sup>2</sup>C TIMING SPECIFICATIONS

$T_A = -55^{\circ}\text{C}$  to  $+150^{\circ}\text{C}$ ,  $V_{DD} = 2.7\text{ V}$  to  $5.5\text{ V}$ , unless otherwise noted. All input signals are specified with rise time ( $t_R$ ) = fall time ( $t_F$ ) =  $5\text{ ns}$  (10% to 90% of  $V_{DD}$ ) and timed from a voltage level of  $1.6\text{ V}$ .

**Table 2.**

Parameter	Min	Typ	Max	Unit	Test Conditions/Comments
SERIAL INTERFACE <sup>1, 2</sup>					See Figure 2
SCL Frequency	0		400	kHz	
SCL High Pulse Width, $t_{HIGH}$	0.6			$\mu\text{s}$	
SCL Low Pulse Width, $t_{LOW}$	1.3			$\mu\text{s}$	
SCL, SDA Rise Time, $t_R$			0.3	$\mu\text{s}$	
SCL, SDA Fall Time, $t_F$			0.3	$\mu\text{s}$	
Hold Time (Start Condition), $t_{HD:STA}$	0.6			$\mu\text{s}$	After this period, the first clock is generated
Setup Time (Start Condition), $t_{SU:STA}$	0.6			$\mu\text{s}$	Relevant for repeated start condition
Data Setup Time, $t_{SU:DAT}$	0.25			$\mu\text{s}$	$V_{DD} \geq 3.0\text{ V}$
	0.35			$\mu\text{s}$	$V_{DD} < 3.0\text{ V}$
Setup Time (Stop Condition), $t_{SU:STO}$	0.6			$\mu\text{s}$	
Data Hold Time, $t_{HD:DAT}$ (Master)	0			$\mu\text{s}$	
Bus-Free Time (Between Stop and Start Condition), $t_{BUF}$	1.3			$\mu\text{s}$	

<sup>1</sup> Sample tested during initial release to ensure compliance.

<sup>2</sup> All input signals are specified with input rise/fall times =  $3\text{ ns}$ , measured between the 10% and 90% points. Timing reference points at 50% for inputs and outputs. Output load =  $10\text{ pF}$ .

### Timing Diagram

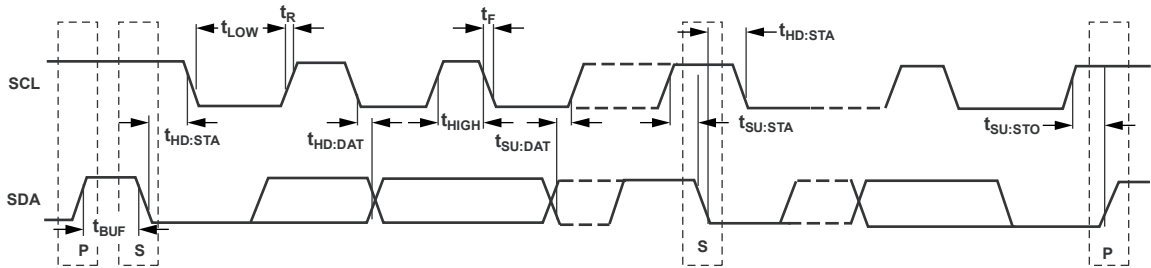

## ABSOLUTE MAXIMUM RATINGS

Table 3.

Parameter	Rating
V <sub>DD</sub> to GND	-0.3 V to +7 V
SDA Voltage to GND	-0.3 V to V <sub>DD</sub> + 0.3 V
SCL Output Voltage to GND	-0.3 V to V <sub>DD</sub> + 0.3 V
A0 Input Voltage to GND	-0.3 V to V <sub>DD</sub> + 0.3 V
A1 Input Voltage to GND	-0.3 V to V <sub>DD</sub> + 0.3 V
CT and INT Output Voltage to GND	-0.3 V to V <sub>DD</sub> + 0.3 V
ESD Rating (Human Body Model)	2.0 kV
Operating Temperature Range	-55°C to +150°C
Storage Temperature Range	-65°C to +160°C
Maximum Junction Temperature, T <sub>JMAX</sub>	150°C
8-Lead SOIC-N (R-8)	
Power Dissipation <sup>1</sup>	$W_{MAX} = (T_{JMAX} - T_A) / \theta_{JA}$
Thermal Impedance <sup>3</sup>	
θ <sub>JA</sub> , Junction-to-Ambient (Still Air)	121°C/W
θ <sub>JC</sub> , Junction-to-Case	56°C/W
IR Reflow Soldering	220°C
Peak Temperature (RoHS-Compliant Package)	260°C (0°C)
Time at Peak Temperature	20 sec to 40 sec
Ramp-Up Rate	3°C/sec maximum
Ramp-Down Rate	-6°C/sec maximum
Time from 25°C to Peak Temperature	8 minutes maximum

<sup>1</sup> Values relate to package being used on a standard 2-layer PCB. This gives a worst-case θ<sub>JA</sub> and θ<sub>JC</sub>. See Figure 3 for a plot of maximum power dissipation vs. ambient temperature (T<sub>A</sub>).

<sup>2</sup> T<sub>A</sub> = ambient temperature.

<sup>3</sup> Junction-to-case resistance is applicable to components featuring a preferential flow direction, for example, components mounted on a heat sink. Junction-to-ambient is more useful for air-cooled, PCB-mounted components.

Stresses above those listed under Absolute Maximum Ratings may cause permanent damage to the device. This is a stress rating only; functional operation of the device at these or any other conditions above those indicated in the operational section of this specification is not implied. Exposure to absolute maximum rating conditions for extended periods may affect device reliability.

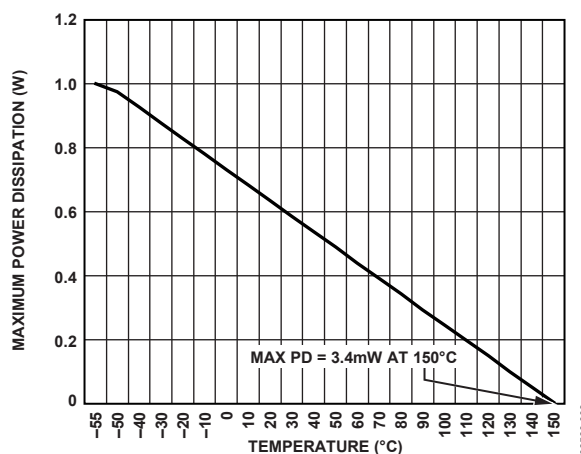

Figure 3. SOIC\_N Maximum Power Dissipation vs. Temperature

### ESD CAUTION



**ESD (electrostatic discharge) sensitive device.**

Charged devices and circuit boards can discharge without detection. Although this product features patented or proprietary protection circuitry, damage may occur on devices subjected to high energy ESD. Therefore, proper ESD precautions should be taken to avoid performance degradation or loss of functionality.

# ADT7410

## PIN CONFIGURATION AND FUNCTION DESCRIPTIONS

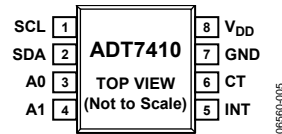

Figure 4. Pin Configuration

Table 4. Pin Function Descriptions

Pin No.	Mnemonic	Description
1	SCL	I <sup>2</sup> C Serial Clock Input. The serial clock is used to clock in and clock out data to and from any register of the ADT7410. Open-drain configuration. A pull-up resistor is required, typically 10 k $\Omega$ .
2	SDA	I <sup>2</sup> C Serial Data Input/Output. Serial data to and from the part is provided on this pin. Open-drain configuration. A pull-up resistor is required, typically 10 k $\Omega$ .
3	A0	I <sup>2</sup> C Serial Bus Address Selection Pin. Logic input. Connect to GND or V <sub>DD</sub> to set an I <sup>2</sup> C address.
4	A1	I <sup>2</sup> C Serial Bus Address Selection Pin. Logic input. Connect to GND or V <sub>DD</sub> to set an I <sup>2</sup> C address.
5	INT	Overtemperature and Undertemperature Indicator. Logic output. Power-up default setting is as an active low comparator interrupt. Open-drain configuration. A pull-up resistor is required, typically 10 k $\Omega$ .
6	CT	Critical Overtemperature Indicator. Logic output. Power-up default polarity is active low. Open-drain configuration. A pull-up resistor is required, typically 10 k $\Omega$ .
7	GND	Analog and Digital Ground.
8	V <sub>DD</sub>	Positive Supply Voltage (2.7 V to 5.5 V). The supply should be decoupled with a 0.1 $\mu$ F ceramic capacitor to ground.

# TYPICAL PERFORMANCE CHARACTERISTICS

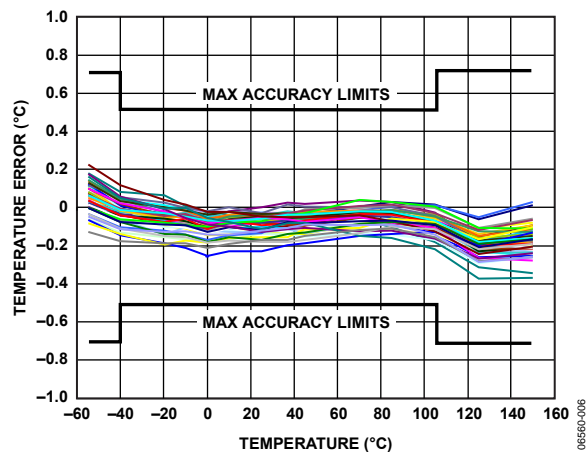

Figure 5. Temperature Accuracy at 3 V

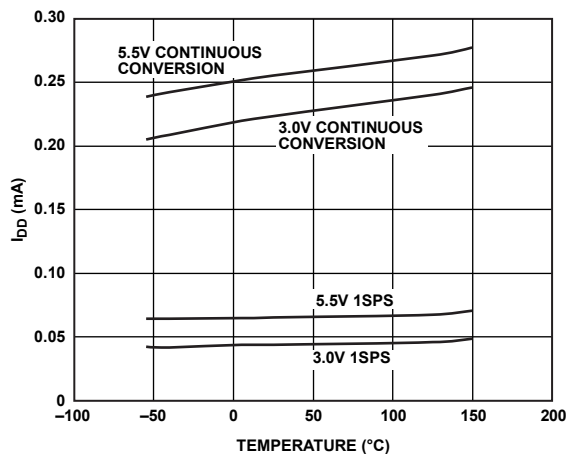

Figure 7. Operating Supply Current vs. Temperature

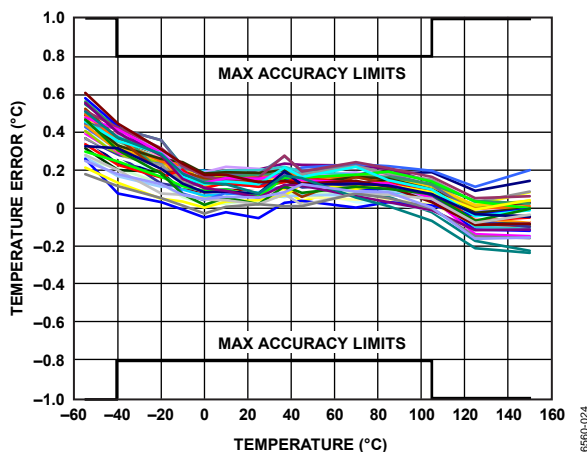

Figure 6. Temperature Accuracy at 5 V

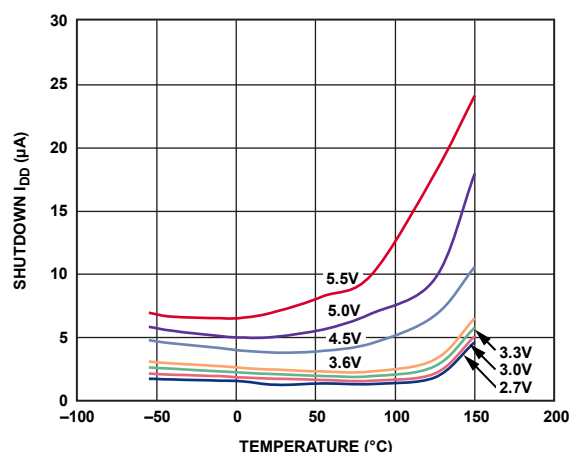

Figure 8. Shutdown Current vs. Temperature

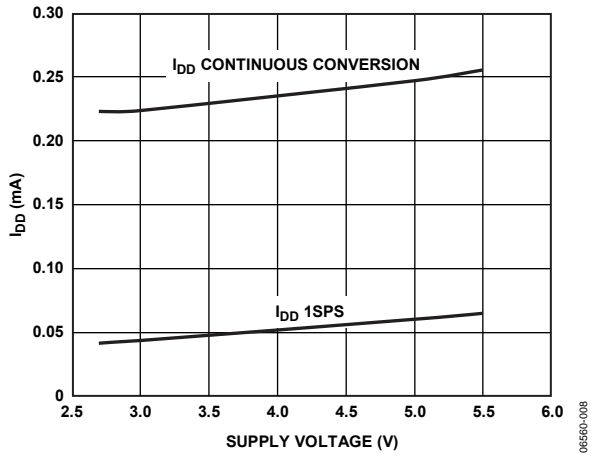

Figure 9. Average Operating Supply Current vs. Supply Voltage at 25°C

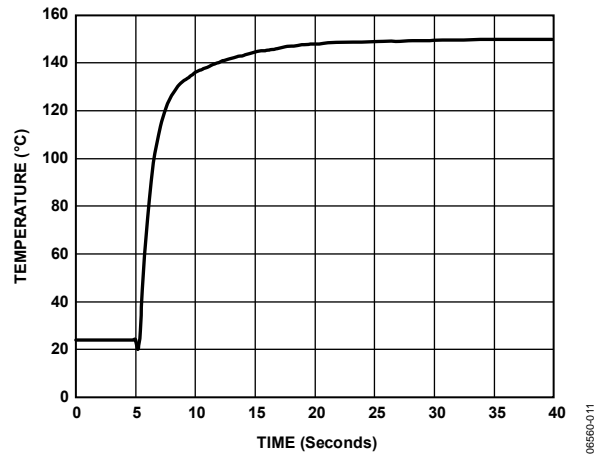

Figure 11. Response to Thermal Shock

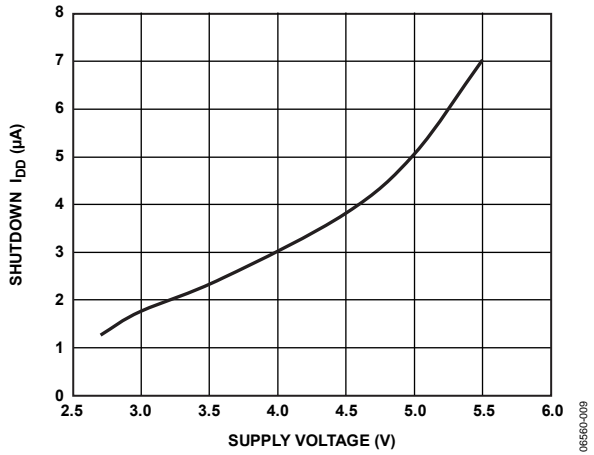

Figure 10. Shutdown Current vs. Supply Voltage at 25°C



## THEORY OF OPERATION

### CIRCUIT INFORMATION

The ADT7410 is a 13-bit digital temperature sensor that is extendable to 16 bits for greater resolution. An on-board temperature sensor generates a voltage proportional to absolute temperature, which is compared to an internal voltage reference and input to a precision digital modulator.

The on-board temperature sensor has excellent accuracy and linearity over the entire rated temperature range without needing correction or calibration by the user.

The sensor output is digitized by a sigma-delta ( $\Sigma$ - $\Delta$ ) modulator, also known as the charge balance type analog-to-digital converter. This type of converter utilizes time-domain oversampling and a high accuracy comparator to deliver 16 bits of resolution in an extremely compact circuit.

Configuration register functions consist of

- Switching between 13-bit and 16-bit resolution
- Switching between normal operation and full power-down
- Switching between comparator and interrupt event modes on the INT and CT pins
- Setting the active polarity of the CT and INT pins
- Setting the number of faults that activate CT and INT
- Enabling the standard one-shot mode and 1 SPS mode

### CONVERTER DETAILS

The  $\Sigma$ - $\Delta$  modulator consists of an input sampler, a summing network, an integrator, a comparator, and a 1-bit DAC. This architecture creates a negative feedback loop and minimizes the integrator output by changing the duty cycle of the comparator output in response to input voltage changes. The comparator samples the output of the integrator at a much higher rate than the input sampling frequency. This oversampling spreads the quantization noise over a much wider band than that of the input signal, improving overall noise performance and increasing accuracy.

The modulated output of the comparator is encoded using a circuit technique that results in  $I^2C$  temperature data.

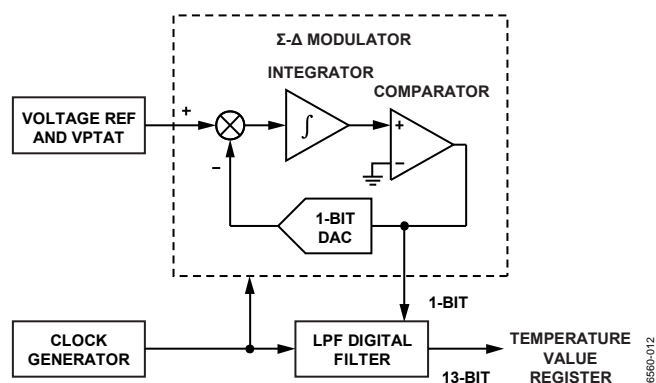

Figure 12.  $\Sigma$ - $\Delta$  Modulator

### TEMPERATURE MEASUREMENT

In normal mode, the ADT7410 runs an automatic conversion sequence. During this automatic conversion sequence, a conversion takes 240 ms to complete and the ADT7410 is continuously converting. This means that as soon as one temperature conversion is completed, another temperature conversion begins. Each temperature conversion result is stored in the temperature value registers and is available through the  $I^2C$  interface. In continuous conversion mode, the read operation provides the most recent converted result.

On power-up, the first conversion is a fast conversion, taking typically 6 ms. If the temperature exceeds 147°C, the CT pin asserts low. If the temperature exceeds 64°C, the INT pin asserts low. Fast conversion temperature accuracy is typically within  $\pm 5^\circ\text{C}$ .

The conversion clock for the part is generated internally. No external clock is required except when reading from and writing to the serial port.

The measured temperature value is compared with a critical temperature limit (stored in the 16-bit  $T_{\text{CRIT}}$  setpoint read/write register), a high temperature limit (stored in the 16-bit  $T_{\text{HIGH}}$  setpoint read/write register), and a low temperature limit (stored in the 16-bit  $T_{\text{LOW}}$  setpoint read/write register). If the measured value exceeds these limits, the INT pin is activated; and if it exceeds the  $T_{\text{CRIT}}$  limit, the CT pin is activated. The INT and CT pins are programmable for polarity via the configuration register, and the INT and CT pins are also programmable for interrupt mode via the configuration register.

## ONE-SHOT MODE

Setting Bit 5 to 1 and Bit 6 to 0 of the configuration register (Register Address 0x03) enables the one-shot mode. When this mode is enabled, the ADT7410 immediately completes a conversion and then goes into shutdown mode.

Wait for a minimum of 240 ms after writing to the one-shot bits before reading back the temperature from the temperature value register. This time ensures that the ADT7410 has time to power up and complete a conversion.

The one-shot mode is useful when one of the circuit design priorities is to reduce power consumption.

## 1 SPS MODE

In this mode, the part performs one measurement per second. A conversion takes only 60 ms, and it remains in the idle state for the remaining 940 ms period. This mode is enabled by writing 0 to Bit 5 and 1 to Bit 6 of the configuration register (Register Address 0x03).

## CT and INT Operation in One-Shot Mode

See Figure 13 for more information on one-shot CT pin operation for  $T_{CRIT}$  overtemperature events when one of the limits is exceeded. Note that in interrupt mode, a read from any register resets the INT and CT pins.

For the INT pin in the comparator mode, if the temperature drops below the  $T_{HIGH} - T_{HYST}$  value or goes above the  $T_{LOW} + T_{HYST}$  value, a write to the one-shot bits (Bit 5 and Bit 6 of the configuration register, Register Address 0x03) resets the INT pin.

For the CT pin in the comparator mode, if the temperature drops below the  $T_{CRIT} - T_{HYST}$  value, a write to the one-shot bits (Bit 5 and Bit 6 of the configuration register, Register Address 0x03) resets the CT pin. See Figure 13.

Note that when using one-shot mode, ensure that the refresh rate is appropriate to the application being used.

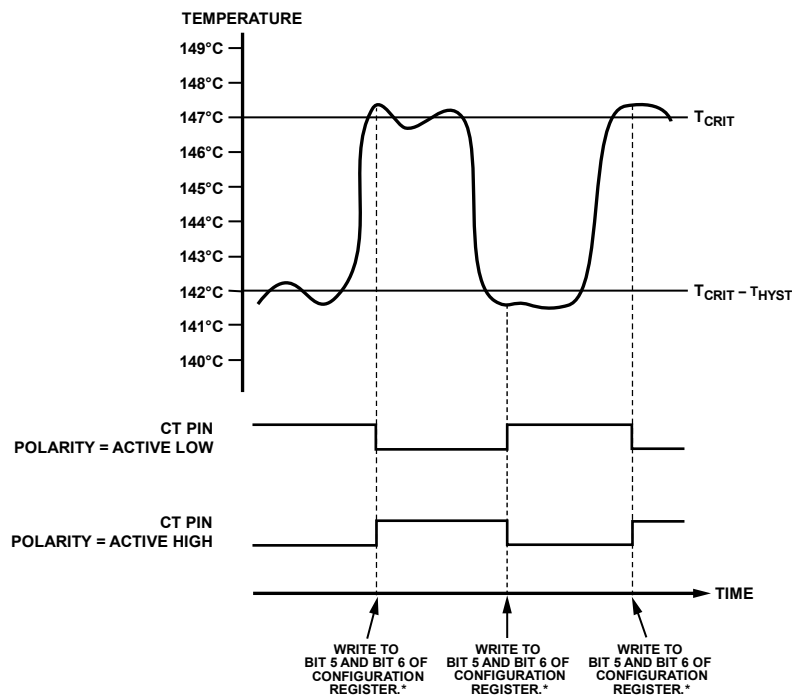

\*THERE IS A 240ms DELAY BETWEEN WRITING TO THE CONFIGURATION REGISTER TO START A STANDARD ONE-SHOT CONVERSION AND THE CT PIN GOING ACTIVE. THIS IS DUE TO THE CONVERSION TIME. THE DELAY IS 60ms IN THE CASE OF A 1 SPS CONVERSION.

06560-013

Figure 13. One-Shot CT Pin

## SHUTDOWN

The ADT7410 can be placed in shutdown mode by writing 1 to Bit 5 and 1 to Bit 6 of the configuration register (Register Address 0x03), in which case the entire IC is shut down and no further conversions are initiated until the ADT7410 is taken out of shutdown mode. The ADT7410 can be taken out of shutdown mode by writing 0 to Bit 5 and 0 to Bit 6 in the configuration register (Register Address 0x03). The ADT7410 typically takes 1 ms (with a 0.1  $\mu$ F decoupling capacitor) to come out of shutdown mode. The conversion result from the last conversion prior to shutdown can still be read from the ADT7410 even when it is in shutdown mode. When the part is taken out of shutdown mode, the internal clock is started and a conversion is initiated.

## FAULT QUEUE

Bit 0 and Bit 1 of the configuration register (Register Address 0x03) are used to set up a fault queue. The queue can facilitate up to four fault events to prevent false tripping of the INT and CT pins when the ADT7410 is used in a noisy temperature environment. The number of faults set in the queue must occur consecutively to set the INT and CT outputs. For example, if the number of faults set in the queue is four, then four consecutive temperature conversions must occur with each result exceeding a temperature limit in any of the limit registers before the INT and CT pins are activated. If two consecutive temperature conversions exceed a temperature limit and the third conversion does not, the fault count is reset back to zero.

## TEMPERATURE DATA FORMAT

One LSB of the ADC corresponds to 0.0625°C in 13-bit mode. The ADC can theoretically measure a temperature range of 255°C, but the ADT7410 is guaranteed to measure a low value temperature limit of -55°C to a high value temperature limit of +150°C. The temperature measurement result is stored in the 16-bit temperature value register and is compared with the high temperature limits stored in the T<sub>CRIT</sub> setpoint register and the T<sub>HIGH</sub> setpoint register. It is also compared with the low temperature limit stored in the T<sub>LOW</sub> setpoint register.

Temperature data in the temperature value register, the T<sub>CRIT</sub> setpoint register, the T<sub>HIGH</sub> setpoint register, and the T<sub>LOW</sub> setpoint register are represented by a 13-bit twos complement word. The MSB is the temperature sign bit. The three LSBs, Bit 0 to Bit 2, on power-up, are not part of the temperature conversion result and are flag bits for T<sub>CRIT</sub>, T<sub>HIGH</sub>, and T<sub>LOW</sub>. Table 5 shows the 13-bit temperature data format without Bit 0 to Bit 2.

The number of bits in the temperature data-word can be extended to 16 bits, twos complement, by setting Bit 7 to 1 in the configuration register (Register Address 0x03). When using a 16-bit temperature data value, Bit 0 to Bit 2 are not used as flag bits and are, instead, the LSB bits of the temperature value. The power-on default setting has a 13-bit temperature data value.

Reading back the temperature from the temperature value register requires a 2-byte read. Designers that use a 9-bit temperature data format can still use the ADT7410 by ignoring the last four LSBs of the 13-bit temperature value. These four LSBs are Bit 6 to Bit 3 in Table 5.

**Table 5. 13-Bit Temperature Data Format**

Temperature	Digital Output (Binary) Bits[15:3]	Digital Output (Hex)
-55°C	1 1100 1001 0000	0x1C90
-50°C	1 1100 1110 0000	0x1CE0
-25°C	1 1110 0111 0000	0x1E70
-0.0625°C	1 1111 1111 1111	0x1FFF
0°C	0 0000 0000 0000	0x000
+0.0625°C	0 0000 0000 0001	0x001
+25°C	0 0001 1001 0000	0x190
+50°C	0 0011 0010 0000	0x320
+125°C	0 0111 1101 0000	0x7D0
+150°C	0 1001 0110 0000	0x960

## TEMPERATURE CONVERSION FORMULAS

### 16-Bit Temperature Data Format

$$\text{Positive Temperature} = \text{ADC Code (dec)}/128$$

$$\text{Negative Temperature} = (\text{ADC Code (dec)} - 65,536)/128$$

where ADC Code uses all 16 bits of the data byte, including the sign bit.

$$\text{Negative Temperature} = (\text{ADC Code (dec)} - 32,768)/128$$

where Bit 15 (sign bit) is removed from the ADC code.

### 13-Bit Temperature Data Format

$$\text{Positive Temperature} = \text{ADC Code (dec)}/16$$

$$\text{Negative Temperature} = (\text{ADC Code (dec)} - 8192)/16$$

where ADC Code uses the first 13 MSBs of the data byte, including the sign bit.

$$\text{Negative Temperature} = (\text{ADC Code (dec)} - 4096)/16$$

where Bit 15 (sign bit) is removed from the ADC code.

### 10-Bit Temperature Data Format

$$\text{Positive Temperature} = \text{ADC Code (dec)}/2$$

$$\text{Negative Temperature} = (\text{ADC Code (dec)} - 1024)/2$$

where ADC Code uses all 10 bits of the data byte, including the sign bit.

$$\text{Negative Temperature} = (\text{ADC Code (dec)} - 512)/2$$

where Bit 9 (sign bit) is removed from the ADC code.

### 9-Bit Temperature Data Format

$$\text{Positive Temperature} = \text{ADC Code (dec)}$$

$$\text{Negative Temperature} = \text{ADC Code (dec)} - 512$$

where ADC Code uses all nine bits of the data byte, including the sign bit.

$$\text{Negative Temperature} = \text{ADC Code (dec)} - 256$$

where Bit 8 (sign bit) is removed from the ADC code.

## REGISTERS

The ADT7410 contains 14 registers:

- Nine temperature registers
- A status register
- An ID register
- A configuration register
- An address pointer register
- A software reset

All registers are eight bits wide. The temperature value registers, the status register, and the ID register are read-only. The software reset is a write-only register. On power-up, the address pointer register is loaded with 0x00 and points to the temperature value register MSB.

**Table 6. ADT7410 Registers**

Register Address	Description	Power-On Default
0x00	Temperature value most significant byte	0x00
0x01	Temperature value least significant byte	0x00
0x02	Status	0x00
0x03	Configuration	0x00
0x04	T <sub>HIGH</sub> setpoint most significant byte	0x20 (64°C)
0x05	T <sub>HIGH</sub> setpoint least significant byte	0x00 (64°C)
0x06	T <sub>LOW</sub> setpoint most significant byte	0x05 (10°C)
0x07	T <sub>LOW</sub> setpoint least significant byte	0x00 (10°C)
0x08	T <sub>CRIT</sub> setpoint most significant byte	0x49 (147°C)
0x09	T <sub>CRIT</sub> setpoint least significant byte	0x80 (147°C)
0x0A	T <sub>HYST</sub> setpoint	0x05 (5°C)
0x0B	ID	0xCX
0x2F	Software reset	0xFF

## ADDRESS POINTER REGISTER

This register is always the first register written to during a write to the ADT7410. It should be set to the address of the register to which the write or read transaction is intended. Table 7 shows the register address of each register on the ADT7410. The default value of the address pointer register is 0x00.

**Table 7. Address Pointer Register**

P7	P6	P5	P4	P3	P2	P1	P0
ADD7	ADD6	ADD5	ADD4	ADD3	ADD2	ADD1	ADD0

## TEMPERATURE VALUE REGISTERS

The temperature value most significant byte (MSB) and temperature value least significant byte (LSB) registers store the temperature measured by the internal temperature sensor. The temperature is stored in twos complement format with the MSB being the temperature sign bit. When reading from these registers, the eight MSBs (Bit 7 to Bit 15) are read first from Register Address 0x00 and then the eight LSBs (Bit 0 to Bit 7) are read from Register Address 0x01. Only the temperature value most significant byte (Register Address 0x00) needs to be loaded into the address pointer register as the address pointer autoincrements to the Temperature value least significant byte address (Register Address 0x01).

Bit 0 to Bit 2 are event alarm flags for T<sub>CRIT</sub>, T<sub>HIGH</sub>, and T<sub>LOW</sub>. When the ADC is configured to convert the temperature to a 16-bit digital value then Bit 0 to Bit 2 are no longer used as flag bits and are instead used as the LSB bits for the extended digital value.

**Table 8. Temperature Value MSB Register (Register Address 0x00)**

Bit	Default Value	Type	Name	Description
[8:14]	0000000	R	Temp	Temperature value in twos complement format
[15]	0	R	Sign	Sign bit, indicates if the temperature value is negative or positive

**Table 9. Temperature Value LSB Register (Register Address 0x01)**

Bit	Default Value	Type	Name	Description
[0]	0	R	T <sub>LOW</sub> flag/LSB0	Flags a T <sub>LOW</sub> event if the configuration register, Register Address 0x03[7] = 0 (13-bit resolution). When the temperature value is below T <sub>LOW</sub> , this bit is set to 1. Contains the Least Significant Bit 0 of the 15-bit temperature value if the configuration register, Register Address 0x03[7] = 1 (16-bit resolution).
[1]	0	R	T <sub>HIGH</sub> flag/LSB1	Flags a T <sub>HIGH</sub> event if the configuration register, Register Address 0x03[7] = 0 (13-bit resolution). When the temperature value is above T <sub>HIGH</sub> , this bit is set to 1. Contains the Least Significant Bit 1 of the 15-bit temperature value if the configuration register, Register Address 0x03[7] = 1 (16-bit resolution).
[2]	0	R	T <sub>CRIT</sub> flag/LSB2	Flags a T <sub>CRIT</sub> event if the configuration register, Register Address 0x03[7] = 0 (13-bit resolution). When the temperature value exceeds T <sub>CRIT</sub> , this bit is set to 1. Contains the Least Significant Bit 2 of the 15-bit temperature value if the configuration register, Register Address 0x03[7] = 1 (16-bit resolution).
[3:7]	00000	R	Temp	Temperature value in twos complement format.

# ADT7410

## STATUS REGISTER

This 8-bit read-only register reflects the status of the overtemperature and undertemperature interrupts that can cause the CT and INT pins to go active. It also reflects the status of a temperature conversion operation. The interrupt flags in this register are reset by a read operation to the status register and/or when the temperature value returns within the temperature limits, including hysteresis. The RDY bit is reset after a read from the

temperature value register. In one-shot and 1 SPS modes, the RDY bit is reset after a write to the one-shot bits.

## CONFIGURATION REGISTER

This 8-bit read/write register stores various configuration modes for the ADT7410, including shutdown, overtemperature and undertemperature interrupts, one-shot, continuous conversion, interrupt pins polarity, and overtemperature fault queues.

**Table 10. Status Register (Register Address 0x02)**

Bit	Default Value	Type	Name	Description
[0:3]	0000	R	Unused	Reads back 0.
[4]	0	R	T <sub>LOW</sub>	This bit is set to 1 when the temperature goes below the T <sub>LOW</sub> temperature limit. The bit clears to 0 when the status register is read and/or when the temperature measured goes back above the limit set in the setpoint T <sub>LOW</sub> + T <sub>HYST</sub> registers.
[5]	0	R	T <sub>HIGH</sub>	This bit is set to 1 when the temperature goes above the T <sub>HIGH</sub> temperature limit. The bit clears to 0 when the status register is read and/or when the temperature measured goes back below the limit set in the setpoint T <sub>HIGH</sub> – T <sub>HYST</sub> registers.
[6]	0	R	T <sub>CRIT</sub>	This bit is set to 1 when the temperature goes above the T <sub>CRIT</sub> temperature limit. This bit clears to 0 when the status register is read and/or when the temperature measured goes back below the limit set in the setpoint T <sub>CRIT</sub> – T <sub>HYST</sub> registers.
[7]	1	R	RDY	This bit goes low when the temperature conversion result is written into the temperature value register. It is reset to 1 when the temperature value register is read. In one-shot and 1 SPS modes, this bit is reset after a write to the one-shot bits.

**Table 11. Configuration Register (Register Address 0x03)**

Bit	Default Value	Type	Name	Description
[0:1]	00	R/W	Fault queue	These two bits set the number of undertemperature/overtemperature faults that can occur before setting the INT and CT pins. This helps to avoid false triggering due to temperature noise. 00 = 1 fault (default). 01 = 2 faults. 10 = 3 faults. 11 = 4 faults.
[2]	0	R/W	CT pin polarity	This bit selects the output polarity of the CT pin. 0 = active low. 1 = active high.
[3]	0	R/W	INT pin polarity	This bit selects the output polarity of the INT pin. 0 = active low. 1 = active high.
[4]	0	R/W	INT/CT mode	This bit selects between comparator mode and interrupt mode. 0 = interrupt mode 1 = comparator mode
[5:6]	00	R/W	Operation mode	These two bits set the operational mode for the ADT7410. 00 = continuous conversion (default). When one conversion is finished, the ADT7410 starts another. 01 = one shot. Conversion time is typically 240 ms. 10 = 1 SPS mode. Conversion time is typically 60 ms. This operational mode reduces the average current consumption. 11 = shutdown. All circuitry except interface circuitry is powered down.
[7]	0	R/W	Resolution	This bit sets up the resolution of the ADC when converting. 0 = 13-bit resolution. Sign bit + 12 bits gives a temperature resolution of 0.0625°C. 1 = 16-bit resolution. Sign bit + 15 bits gives a temperature resolution of 0.0078°C.

### T<sub>HIGH</sub> SETPOINT REGISTERS

The T<sub>HIGH</sub> setpoint MSB and T<sub>HIGH</sub> setpoint LSB registers store the overtemperature limit value. An overtemperature event occurs when the temperature value stored in the temperature value register exceeds the value stored in this register. The INT pin is activated if an overtemperature event occurs. The temperature is stored in twos complement format with the MSB being the temperature sign bit.

When reading from this register, the eight MSBs (Bit 15 to Bit 8) are read first from Register Address 0x04 and then the eight LSBs (Bit 7 to Bit 0) are read from Register Address 0x05. Only Register Address 0x04 (T<sub>HIGH</sub> setpoint MSB) needs to be loaded into the address pointer register as the address pointer auto-increments to Register Address 0x05 (T<sub>HIGH</sub> setpoint LSB).

The default setting for the T<sub>HIGH</sub> setpoint is 64°C.

### T<sub>LOW</sub> SETPOINT REGISTERS

The T<sub>LOW</sub> setpoint MSB and T<sub>LOW</sub> setpoint LSB registers store the undertemperature limit value. An undertemperature event occurs when the temperature value stored in the temperature value register is less than the value stored in this register. The INT pin is activated if an undertemperature event occurs. The temperature is stored in twos complement format with the MSB being the temperature sign bit.

When reading from this register, the eight MSBs (Bit 15 to Bit 8) are read first from Register Address 0x06 and then the eight LSBs (Bit 7 to Bit 0) are read from Register Address 0x07. Only the Register Address 0x06 (T<sub>LOW</sub> setpoint MSB) needs to be loaded into the address pointer register as the address pointer auto-increments to Register Address 0x07 (T<sub>LOW</sub> setpoint LSB).

The default setting for the T<sub>LOW</sub> setpoint is 10°C.

### T<sub>CRIT</sub> SETPOINT REGISTERS

The T<sub>CRIT</sub> setpoint MSB and T<sub>CRIT</sub> setpoint LSB registers store the critical overtemperature limit value. A critical overtemperature event occurs when the temperature value stored in the temperature value register exceeds the value stored in this register. The CT pin is activated if a critical overtemperature event occurs. The temperature is stored in twos complement format with the MSB being the temperature sign bit.

When reading from this register, the eight MSBs (Bit 15 to Bit 8) are read first from Register Address 0x08 and then the eight LSBs (Bit 7 to Bit 0) are read from Register Address 0x09.

Only the Register Address 0x08 (T<sub>CRIT</sub> setpoint MSB) needs to be loaded into the address pointer register as the address pointer auto-increments to Register Address 0x09 (T<sub>CRIT</sub> setpoint LSB).

The default setting for the T<sub>CRIT</sub> limit is 147°C.

**Table 12. T<sub>HIGH</sub> Setpoint MSB Register (Register Address 0x04)**

Bit	Default Value	Type	Name	Description
[15:8]	0x20	R/W	T <sub>HIGH</sub> MSB	MSBs of the overtemperature limit, stored in twos complement format.

**Table 13. T<sub>HIGH</sub> Setpoint LSB Register (Register Address 0x05)**

Bit	Default Value	Type	Name	Description
[7:0]	0x00	R/W	T <sub>HIGH</sub> LSB	LSBs of the overtemperature limit, stored in twos complement format.

**Table 14. T<sub>LOW</sub> Setpoint MSB Register (Register Address 0x06)**

Bit	Default Value	Type	Name	Description
[15:8]	0x05	R/W	T <sub>LOW</sub> MSB	MSBs of the undertemperature limit, stored in twos complement format.

**Table 15. T<sub>LOW</sub> Setpoint LSB Register (Register Address 0x07)**

Bit	Default Value	Type	Name	Description
[7:0]	0x00	R/W	T <sub>LOW</sub> LSB	LSBs of the undertemperature limit, stored in twos complement format.

**Table 16. T<sub>CRIT</sub> Setpoint MSB Register (Register Address 0x08)**

Bit	Default Value	Type	Name	Description
[15:8]	0x49	R/W	T <sub>CRIT</sub> MSB	MSBs of the critical overtemperature limit, stored in twos complement format.

**Table 17. T<sub>CRIT</sub> Setpoint LSB Register (Register Address 0x09)**

Bit	Default Value	Type	Name	Description
[7:0]	0x80	R/W	T <sub>CRIT</sub> LSB	LSBs of the critical overtemperature limit, stored in twos complement format.

# ADT7410

## T<sub>HYST</sub> SETPOINT REGISTER

This 8-bit read/write register stores the temperature hysteresis value for the T<sub>HIGH</sub>, T<sub>LOW</sub>, and T<sub>CRIT</sub> temperature limits. The temperature hysteresis value is stored in straight binary format using four LSBs. Increments are possible in steps of 1°C from 0°C to 15°C. The value in this register is subtracted from the T<sub>HIGH</sub> and T<sub>CRIT</sub> values and added to the T<sub>LOW</sub> value to implement hysteresis.

## ID REGISTER

This 8-bit read-only register stores the manufacturer ID in Bit 3 to Bit 7 and the silicon revision in Bit 0 to Bit 2.

**Table 18. T<sub>HYST</sub> Setpoint Register (Register Address 0x0A)**

Bit	Default Value	Type	Name	Description
[3:0]	0101	R/W	T <sub>HYST</sub>	Hysteresis value, from 0°C to 15°C. Stored in straight binary format. The default setting is 5°C.
[7:4]	0000	R/W	N/A	Not used.

**Table 19. ID Register (Register Address 0x0B)**

Bit	Default Value	Type	Name	Description
[2:0]	XXX	R	Revision ID	Contains the silicon revision identification number
[7:3]	11001	R	Manufacture ID	Contains the manufacturer identification number



## SERIAL INTERFACE

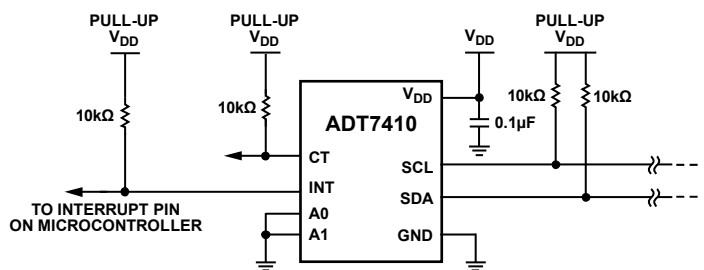

Figure 14. Typical I<sup>2</sup>C Interface Connection

Control of the ADT7410 is carried out via the I<sup>2</sup>C-compatible serial interface. The ADT7410 is connected to this bus as a slave and is under the control of a master device.

Figure 14 shows a typical I<sup>2</sup>C interface connection.

### SERIAL BUS ADDRESS

Like all I<sup>2</sup>C-compatible devices, the ADT7410 has a 7-bit serial address. The five MSBs of this address for the ADT7410 are set to 10010. Pin A1 and Pin A0 set the two LSBs. These pins can be configured two ways, low and high, to give four different address options. Table 20 shows the different bus address options available. The recommended pull-up resistor value on the SDA and SCL lines is 10 kΩ.

Table 20. I<sup>2</sup>C Bus Address Options

Binary							Hex
A6	A5	A4	A3	A2	A1	A0	
1	0	0	1	0	0	0	0x48
1	0	0	1	0	0	1	0x49
1	0	0	1	0	1	0	0x4A
1	0	0	1	0	1	1	0x4B

The serial bus protocol operates as follows:

1. The master initiates data transfer by establishing a start condition, defined as a high-to-low transition on the serial data line, SDA, while the serial clock line, SCL, remains high. This indicates that an address/data stream is going to follow. All slave peripherals connected to the serial bus respond to the start condition and shift in the next eight bits, consisting of a 7-bit address (MSB first) plus a read/write (R/W) bit. The R/W bit determines whether data is written to, or read from, the slave device.

2. The peripheral with the address corresponding to the transmitted address responds by pulling the data line low during the low period before the ninth clock pulse, known as the acknowledge bit. All other devices on the bus then remain idle while the selected device waits for data to be read from or written to it. If the R/W bit is a 0, the master writes to the slave device. If the R/W bit is a 1, the master reads from the slave device.
3. Data is sent over the serial bus in sequences of nine clock pulses, eight bits of data followed by an acknowledge bit from the receiver of data. Transitions on the data line must occur during the low period of the clock signal and remain stable during the high period as a low-to-high transition when the clock is high, which can be interpreted as a stop signal.
4. When all data bytes have been read or written, stop conditions are established. In write mode, the master pulls the data line high during the 10<sup>th</sup> clock pulse to assert a stop condition. In read mode, the master device pulls the data line high during the low period before the ninth clock pulse. This is known as a no acknowledge. The master takes the data line low during the low period before the 10<sup>th</sup> clock pulse, then high during the 10<sup>th</sup> clock pulse to assert a stop condition.

It is not possible to mix read and write in one operation because the type of operation is determined at the beginning and cannot subsequently be changed without starting a new operation.

## WRITING DATA

It is possible to write either a single byte of data or two bytes to the ADT7410, depending on which registers are to be written.

Writing a single byte of data requires the serial bus address, the data register address written to the address pointer register, followed by the data byte written to the selected data register. This is shown in Figure 15.

For the  $T_{HIGH}$  setpoint,  $T_{LOW}$  setpoint, and  $T_{CRIT}$  setpoint registers, it is possible to write to both the MSB and the LSB registers in

the same write transaction. Writing two bytes of data to these registers requires the serial bus address, the data register address of the MSB register written to the address pointer register, followed by the two data bytes written to the selected data register. This is shown in Figure 16.

If more than the required number of data bytes is written to a register, the register ignores these extra data bytes. To write to a different register, a start or repeated start is required.

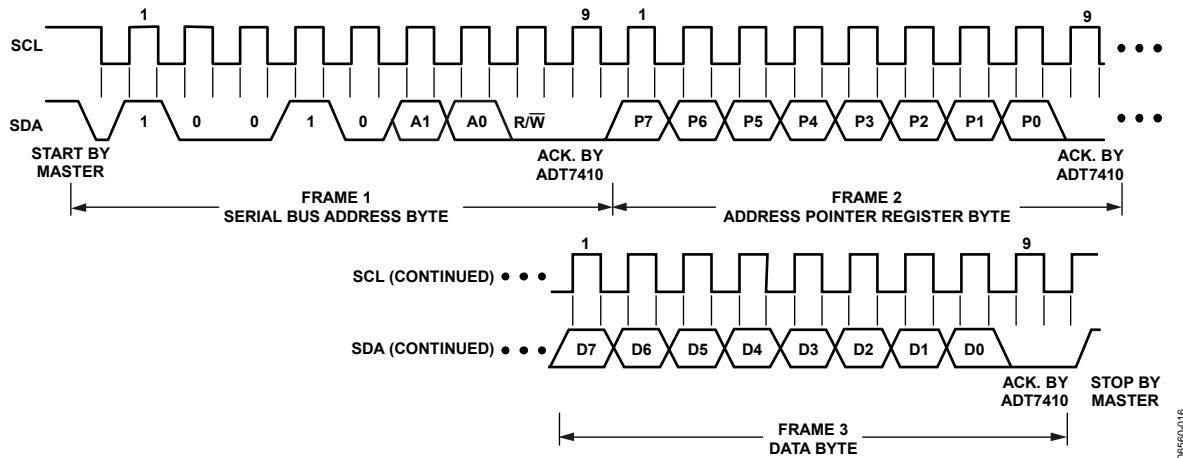

Figure 15. Writing to a Register Followed by a Single Byte of Data

06560-016

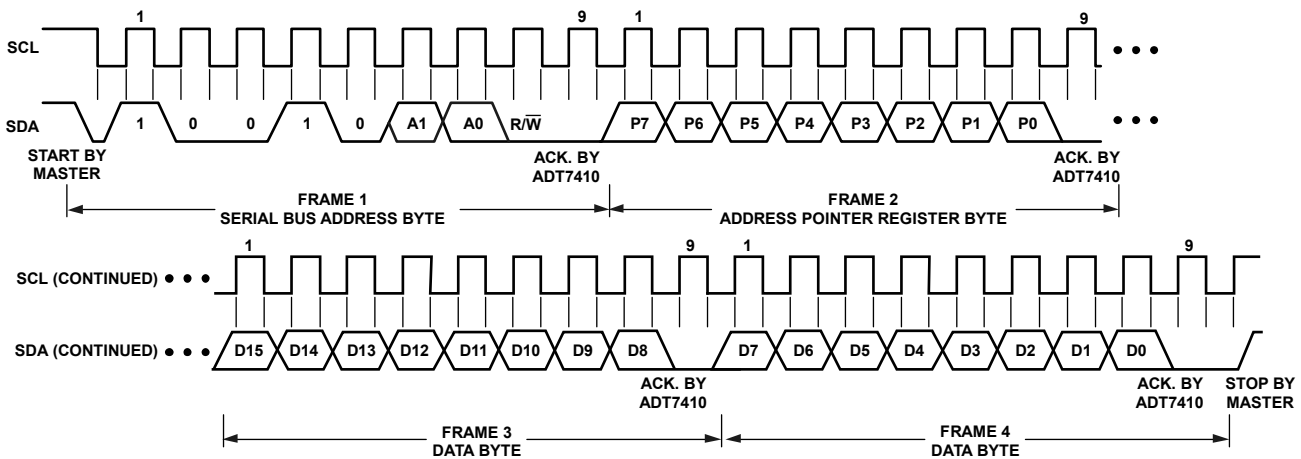

Figure 16. Writing to a Register Followed by Two Bytes of Data

06560-017

## READING DATA

Reading data from the ADT7410 is done in a single data byte operation for the configuration register, the status register, the  $T_{HYST}$  register, and the ID register. A two data byte read operation is needed for the temperature value register,  $T_{HIGH}$  setpoint register,  $T_{LOW}$  setpoint register, and the  $T_{CRIT}$  setpoint register. Reading back the contents of an 8-bit register similar to the configuration register is shown in Figure 17. Reading back the contents of the temperature value register is shown in Figure 18.

Reading back from any register first requires a single-byte write operation to the address pointer register to set up the address of the register that is going to be read from. In the case of reading back from the 2-byte registers, the address pointer automatically increments from the MSB register address to the LSB register address.

To read from another register, execute another write to the address pointer register to set up the relevant register address. Thus, block reads are not possible, that is, there is no I<sup>2</sup>C address pointer autoincrement except when reading back from a 16-bit register. If the address pointer register has previously been set up with the address of the register that is going to receive a read command, there is no need to repeat a write operation to set up the register address again.

## RESET

To reset the ADT7410 without having to reset the entire I<sup>2</sup>C bus, an explicit reset command is provided. This uses a particular address pointer word as a command word to reset the part and upload all default settings. The ADT7410 does not respond to the I<sup>2</sup>C bus commands (do not acknowledge) during the default values upload for approximately 200  $\mu$ s.

The reset command address word is 0x2F.

## GENERAL CALL

When a master issues a slave address consisting of seven 0s with the eighth bit (R/W bit) set to 0, this is known as the general call address. The general call address is for addressing every device connected to the I<sup>2</sup>C bus. The ADT7410 acknowledges this address and reads in the following data byte.

If the second byte is 0x06, the ADT7410 is reset, completely uploading all default values. The ADT7410 does not respond to the I<sup>2</sup>C bus commands (do not acknowledge) while the default values upload for approximately 200  $\mu$ s.

The ADT7410 does not acknowledge any other general call commands.

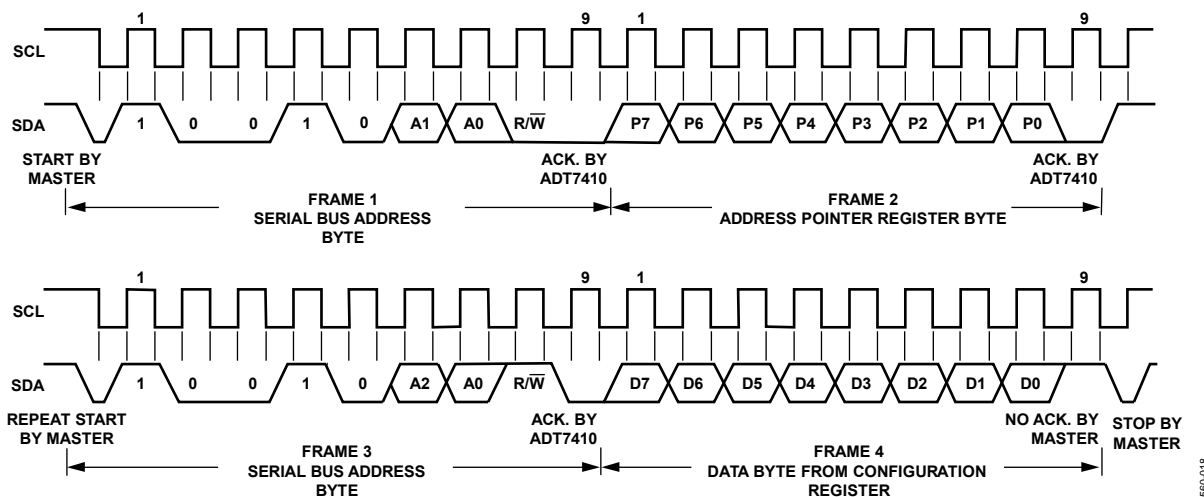
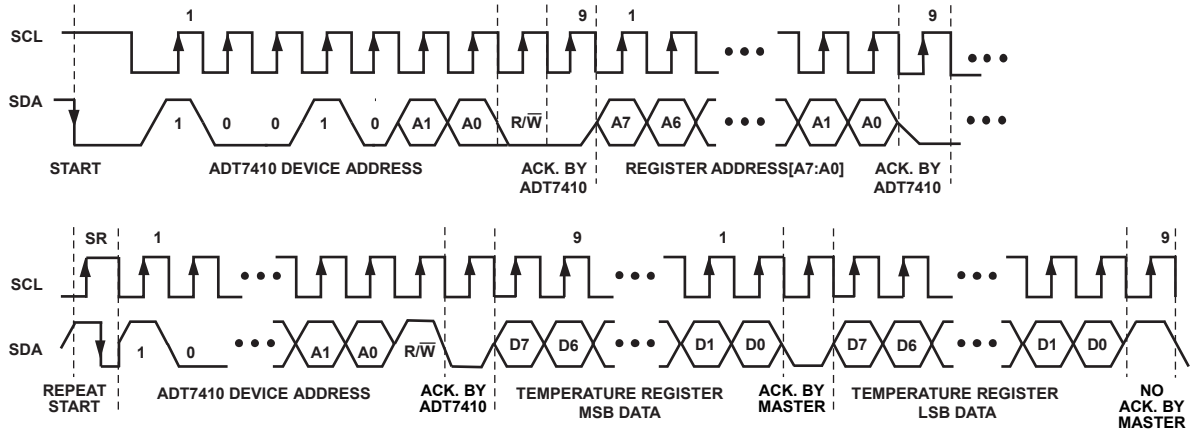

Figure 17. Reading Back Data from the Configuration Register

06560-018

# ADT7410



**NOTES**

1. A START CONDITION AT THE BEGINNING IS DEFINED AS A HIGH-TO-LOW TRANSITION ON SDA WHILE SCLK REMAINS HIGH.
2. A STOP CONDITION AT THE END IS DEFINED AS A LOW-TO-HIGH TRANSITION ON SDA WHILE SCLK REMAINS HIGH.
3. THE MASTER GENERATES THE NO ACKNOWLEDGE AT THE END OF THE READBACK TO SIGNAL THAT IT DOES NOT WANT ADDITIONAL DATA.
4. TEMPERATURE REGISTER MSB DATA AND TEMPERATURE REGISTER LSB DATA ARE ALWAYS SEPARATED BY A LOW ACK BIT.
5. THE R/W BIT IS SET TO A1 TO INDICATE A READBACK OPERATION.

Figure 18. Reading Back Data from the Temperature Value Register

08560-023

## INT AND CT OUTPUTS

The INT and CT pins are open-drain outputs, and both pins require a 10 k $\Omega$  pull-up resistor to  $V_{DD}$ .

### UNDERTEMPERATURE AND OVERTEMPERATURE DETECTION

The INT and CT pins have two undertemperature/overtemperature modes: comparator mode and interrupt mode. The interrupt mode is the default power-up overtemperature mode. The INT output pin becomes active when the temperature is greater than the temperature stored in the  $T_{HIGH}$  setpoint register or less than the temperature stored in the  $T_{LOW}$  setpoint register. How this pin reacts after this event depends on the overtemperature mode selected.

Figure 19 illustrates the comparator and interrupt modes for events exceeding the  $T_{HIGH}$  limit with both pin polarity settings. Figure 20 illustrates the comparator and interrupt modes for events exceeding the  $T_{LOW}$  limit with both pin polarity settings.

#### Comparator Mode

In comparator mode, the INT pin returns to its inactive status when the temperature drops below the  $T_{HIGH} - T_{HYST}$  limit or rises above the  $T_{LOW} + T_{HYST}$  limit.

Putting the ADT7410 into shutdown mode does not reset the INT state in comparator mode.

#### Interrupt Mode

In interrupt mode, the INT pin goes inactive when any ADT7410 register is read. Once the INT pin is reset, it goes active again only when the temperature is greater than the temperature stored in the  $T_{HIGH}$  setpoint register or less than the temperature stored in the  $T_{LOW}$  setpoint register.

Placing the ADT7410 into shutdown mode resets the INT pin in the interrupt mode.

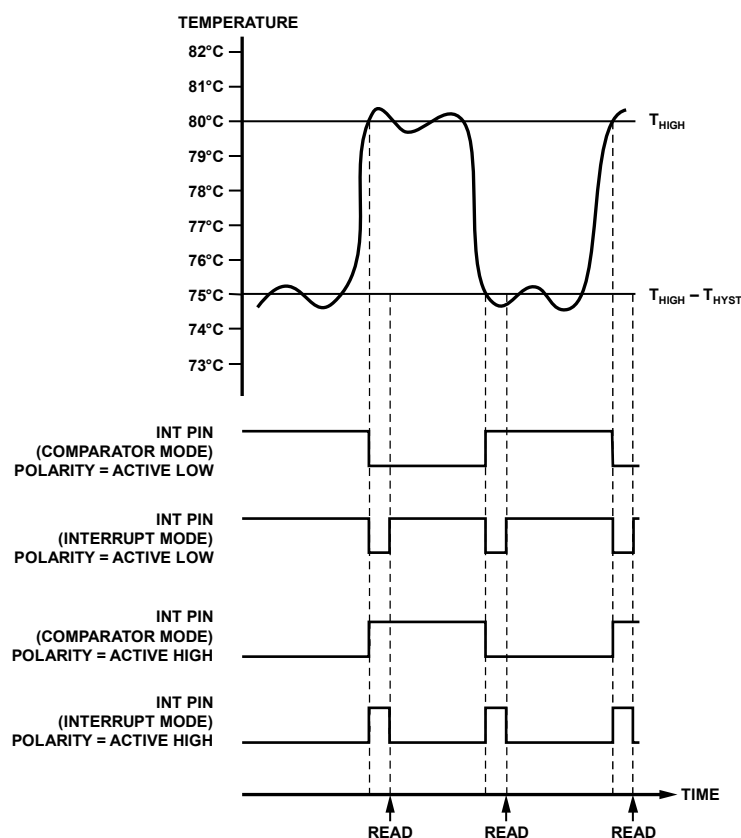

Figure 19. INT Output Temperature Response Diagram for  $T_{HIGH}$  Overtemperature Events

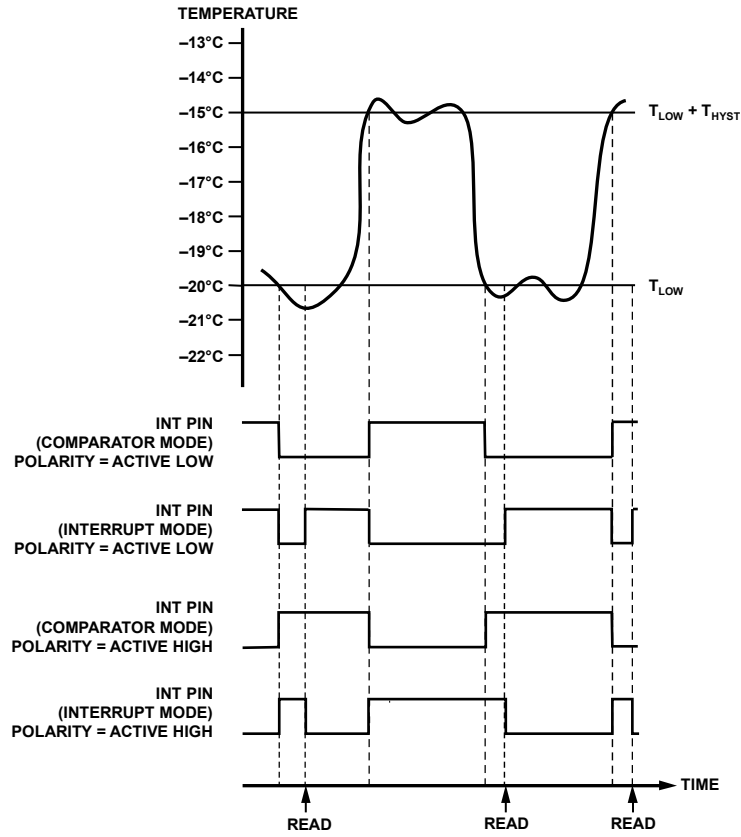

Figure 20. INT Output Temperature Response Diagram for  $T_{Low}$  Undertemperature Events

065560-021

## APPLICATIONS INFORMATION

### THERMAL RESPONSE TIME

The time required for a temperature sensor to settle to a specified accuracy is a function of the thermal mass of the sensor and the thermal conductivity between the sensor and the object being sensed. Thermal mass is often considered equivalent to capacitance. Thermal conductivity is commonly specified using the symbol,  $Q$ , and can be thought of as thermal resistance. It is commonly specified in units of degrees per watt of power transferred across the thermal joint. The time required for the part to settle to the desired accuracy is dependent on the thermal contact established in a particular application and the equivalent power of the heat source. In most applications, it is best to determine the settling time empirically.

### SUPPLY DECOUPLING

Decouple the ADT7410 with a 0.1  $\mu\text{F}$  ceramic capacitor between  $V_{\text{DD}}$  and GND. This is particularly important when the ADT7410 is mounted remotely from the power supply. Precision analog products, such as the ADT7410, require a well-filtered power source. Because the ADT7410 operates from a single supply, it might seem convenient to tap into the digital logic power supply. Unfortunately, the logic supply is often a switch-mode design, which generates noise in the 20 kHz to 1 MHz range. In addition, fast logic gates can generate glitches hundreds of millivolts in amplitude due to wiring resistance and inductance.

If possible, the ADT7410 should be powered directly from the system power supply. This arrangement, shown in Figure 21, isolates the analog section from the logic switching transients. Even if a separate power supply trace is not available, generous supply bypassing reduces supply-line induced errors. Local supply bypassing consisting of a 0.1  $\mu\text{F}$  ceramic capacitor is critical for the temperature accuracy specifications to be achieved. This decoupling capacitor must be placed as close as possible to the  $V_{\text{DD}}$  pin of the ADT7410.

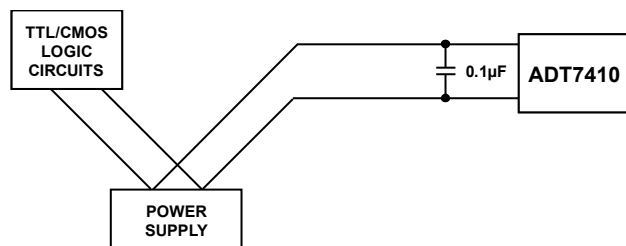

Figure 21. Use of Separate Traces to Reduce Power Supply Noise

### TEMPERATURE MONITORING

The ADT7410 is ideal for monitoring the thermal environment within electronic equipment. For example, the surface-mounted package accurately reflects the exact thermal conditions that affect nearby integrated circuits.

The ADT7410 measures and converts the temperature at the surface of its own semiconductor chip. When the ADT7410 is used to measure the temperature of a nearby heat source, the thermal impedance between the heat source and the ADT7410 must be considered.

When the thermal impedance is determined, the temperature of the heat source can be inferred from the ADT7410 output. As much as 60% of the heat transferred from the heat source to the thermal sensor on the ADT7410 die is discharged via the copper tracks, the package pins, and the bond pads. Of the pins on the ADT7410, the GND pin transfers most of the heat. Therefore, to measure the temperature of a heat source, it is recommended that the thermal resistance between the GND pin of the ADT7410 and the GND of the heat source be reduced as much as possible.

06560-022

## OUTLINE DIMENSIONS

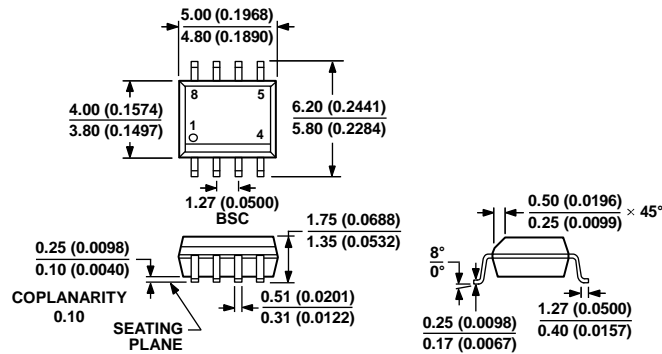

COMPLIANT TO JEDEC STANDARDS MS-012-A A  
 CONTROLLING DIMENSIONS ARE IN MILLIMETERS; INCH DIMENSIONS  
 (IN PARENTHESES) ARE ROUNDED-OFF MILLIMETER EQUIVALENTS FOR  
 REFERENCE ONLY AND ARE NOT APPROPRIATE FOR USE IN DESIGN.

Figure 22. 8-Lead Standard Small Outline Package [SOIC\_N]  
 Narrow Body  
 (R-8)

Dimensions shown in millimeters and (inches)

012407-A

## ORDERING GUIDE

Model	Temperature Range	Temperature Accuracy <sup>1</sup>	Package Description	Package Option
ADT7410TRZ <sup>2</sup>	-55°C to +150°C	±0.5°C	8-Lead SOIC_N	R-8
ADT7410TRZ-REEL <sup>2</sup>	-55°C to +150°C	±0.5°C	8-Lead SOIC_N	R-8
ADT7410TRZ-REEL7 <sup>2</sup>	-55°C to +150°C	±0.5°C	8-Lead SOIC_N	R-8
EVAL-ADT7410EBZ <sup>2</sup>			Evaluation Board	

<sup>1</sup> Maximum accuracy over the -40°C to +105°C temperature range.

<sup>2</sup> Z = RoHS Compliant Part.

Purchase of licensed I<sup>2</sup>C components of Analog Devices or one of its sublicensed Associated Companies conveys a license for the purchaser under the Philips I<sup>2</sup>C Patent Rights to use these components in an I<sup>2</sup>C system, provided that the system conforms to the I<sup>2</sup>C Standard Specification as defined by Philips.