

# High Speed, Matched-Impedance, Parallel Board-to-board Connector

## IT1 Series

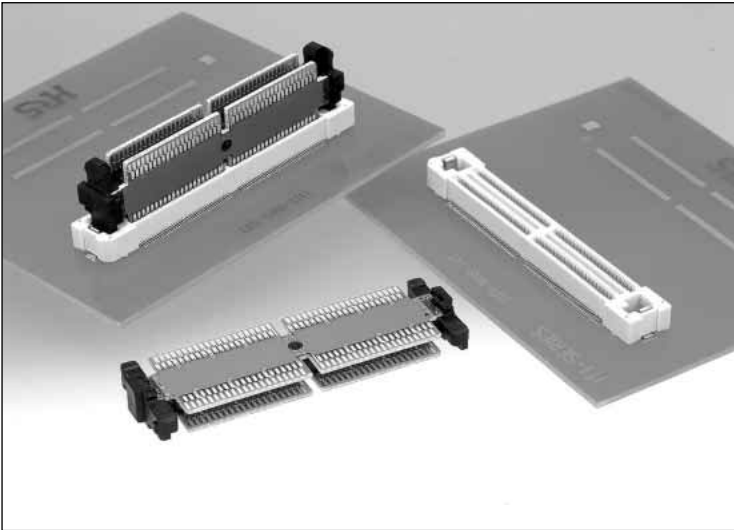

### IT1 Series Outline

High-speed matched-impedance parallel board-to-board connector designed for applications requiring board-to-board spacing with transmission speeds exceeding 1GHz. The connection system has matched impedance of 50 ohm or can be customized. Contacts are on 0.5mm pitch.

### ■ Features

#### 1. Impedance Matching using a 4-Layer Board

The innovative transmission module uses PC boards with a strip line design of transmission lines, providing matched impedance of 50 ohms, for standard product.

#### 2. Supports Multiple Connectors per board

Designed with a tolerance of  $\pm 0.2\text{mm}$  for both the X and Y-axis. The three-piece structure and the  $\pm 0.2\text{mm}$  tolerance allows 3 or more IT1's to be mounted on a single board.

#### 3. Customized Board-to-Board Distance

Board-to-board distance can be customized, from 16mm to 40mm.

Ground lines or additional traces can be added to support high level, high speed transmission or mixed power/signal applications.

#### 4. Signal to Ground Ratio

The standard signal-to-ground ratio is 10:2, which makes reliable matching of the characteristic impedance of each transmission line. This ratio also can be customized.

#### 5. Contact Reliability

Use of double contact points on each of the contacts assures highly reliable performance.

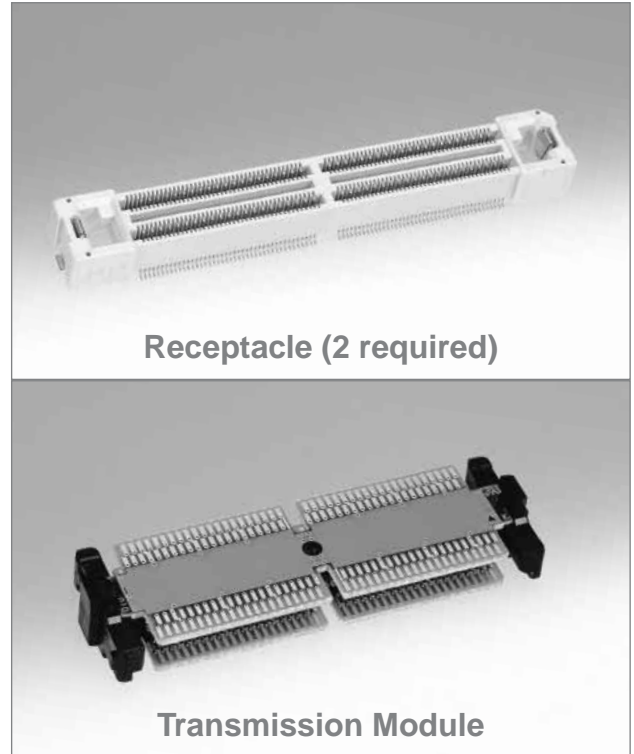

Receptacle (2 required)

Transmission Module

### ● Connection Cross-Sectional Diagram

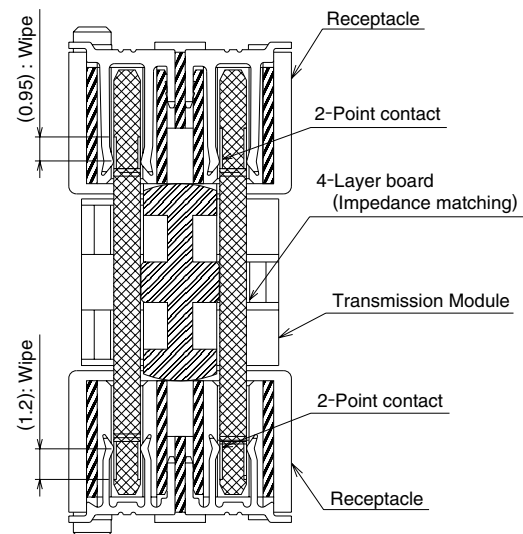

### ■ Applications

Routers, servers, base stations and other telecommunication equipment.

## Product Specifications

Rating	Current rating	0.4 A (Note 1)	Operation Temperature Range	-55°C to +85°C	Storage Temperature Range	-10°C to +60°C (Note 2)
	Voltage rating	50V AC	Operation Humidity Range	Relative humidity 95% max. (No condensation)	Storage Humidity Range	40% to 70% (Note 2)

Item	Specification	Conditions
1. Insulation resistance	100 M ohms min.	Measured at 100V DC
2. Withstanding voltage	No flashover or insulation breakdown	150 V AC/one minute
3. Contact resistance	100 m ohms max.	Measured at 100 mA
4. Vibration	No electrical discontinuity of 1 $\mu$ s or more. No damage, cracks, or parts dislocation.	Frequency of 10 to 55 Hz, 0.75mm single amplitude, for 10 cycles in each of 3 directions
5. Shock	No electrical discontinuity of 1 $\mu$ s. min. No damage, cracks, or parts dislocation	Acceleration of 490 m/s <sup>2</sup> , 11 ms duration, sine half-wave waveform, 3 cycles in each of the 3 axis.
6. Humidity	Contact resistance: 110 m ohms max. Insulation resistance: 100 M ohms min. No damage, cracks, or parts dislocation	96 hours/40°C/ humidity of 90% to 95%
7. Temperature cycle	Contact resistance: 110 m ohms max. Insulation resistance: 100 M ohms min. No damage, cracks, or parts dislocation	Temperature: -55°C → +15°C to +35°C → +85°C → +15°C to +35°C Duration: 30 → 2 to 3 → 30 → 2 to 3 (Minutes) 5 cycles
8. Durability (insertion/ withdrawal)	Contact resistance: 110 m ohms max. No damage, cracks, or parts dislocation.	20 cycles
9. Resistance to Soldering Heat	No deformation of components affecting performance.	Reflow: At the recommended temperature profile Manual soldering: 350°C for 3 seconds

Note1: If the connector is going to be used at a current in excess of the 0.4 A, please contact your Sales Representative.

Note2: The term "storage" refers to products stored for long period of time prior to mounting and use. Operating Temperature Range and Humidity range covers non-conducting condition of installed connectors in storage, shipment or during transportation.

Note3: Information contained in this catalog represents general requirements for this Series. Contact us for the drawings and specifications for a specific part number shown.

## Material

### Receptacles

Part	Material	Finish	Remarks
Insulator	LCP	Color : Beige	UL94V-0
Contacts	Phosphor bronze	Gold plating	—
Metal fittings	Phosphor bronze	Tin plating	—

### Transmission Module

Part	Material	Finish	Remarks
Insulator	PBT	Color : Black	UL94V-0
Board	FR-4	Contact portion : Gold plating	—

## Ordering information

### Receptacles

**IT 1 # - \* S - SV (\* \*)**

①      ②      ③      ④      ⑤      ⑥

### Transmission Module

**IT 1 - \* P / \* - \*H**

①      ③      ④      ⑦      ⑧

① Series name	: IT1	⑤ Lead	SV : Straight SMT
② Locating Post type Blank	: With Locating Post	⑥ Packaging	Blank : Tray (25) : Tray(connectors with attached tape for a vacuum board placement)
A	: Without Locating Post		
③ Number of contacts	: 168, 252	⑦ Number of ground contacts	: 28, 44
④ Connector	S : Receptacle Socket P : Transmission Plug Module	⑧ Board-to-board Distance:	19mm,23mm,30mm

IT1 Series High Speed, Matched Impedance, Parallel Board-to-board Connector System

■ Receptacles - 168 Contacts

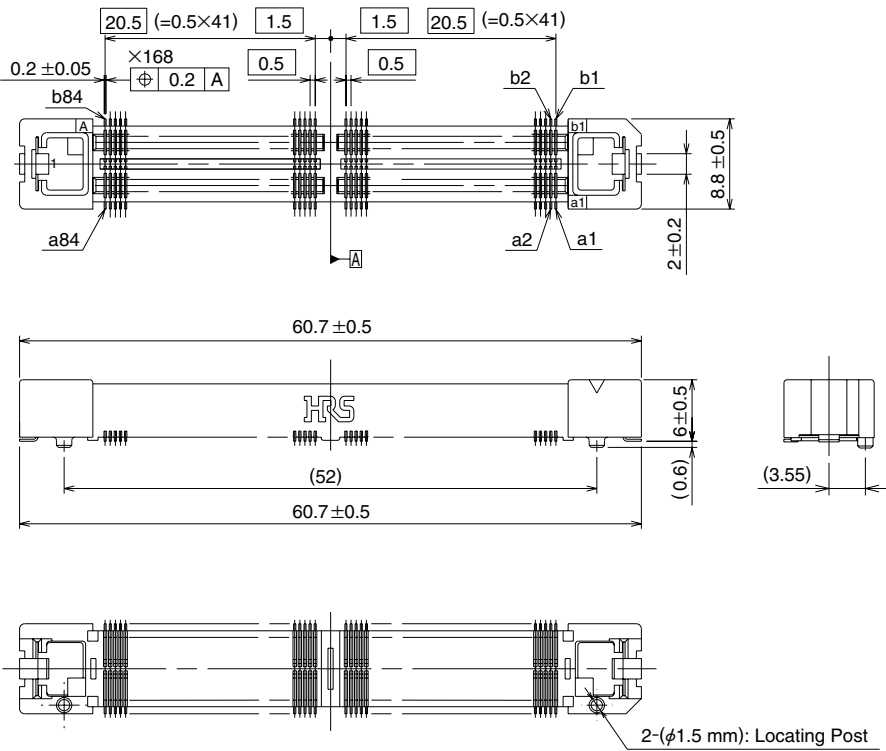

Part Number	CL No.	Locating Post Type	RoHS
IT1-168S-SV	641-0002-0	With Locating Post	YES
IT1A-168S-SV	641-0012-4	Without Locating Post	

◆ Recommended PCB mounting pattern

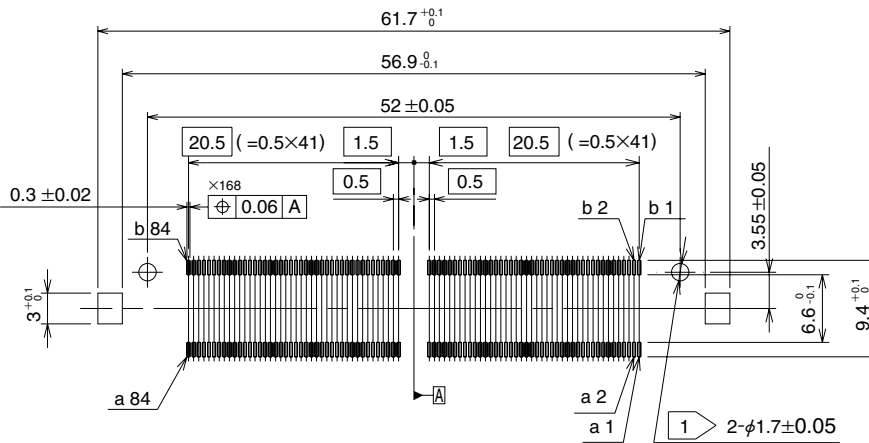

1 Not required for products without Locating Post.

## Receptacles - 252 Contacts

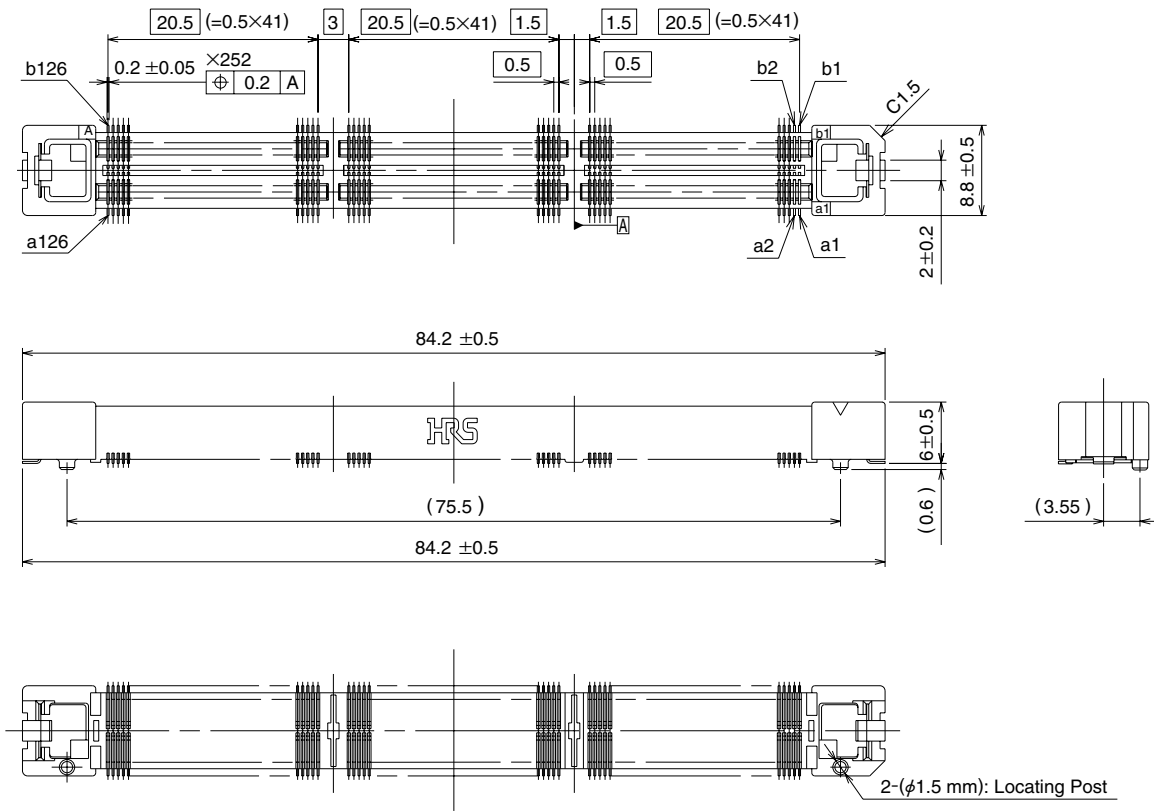

Part Number	CL No.	Locating Post Type	RoHS
IT1-252S-SV	641-0003-3	With Locating Post	YES
IT1A-252S-SV	641-0013-7	Without Locating Post	

## Recommended PCB mounting pattern

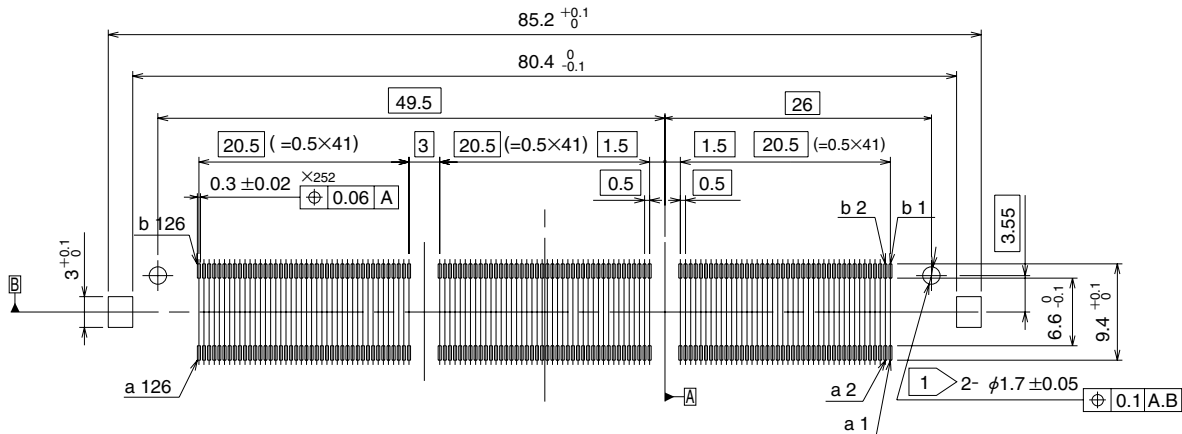

1 Not required for products without locating Post.

IT1 Series High Speed, Matched Impedance, Parallel Board-to-board Connector System

## Transmission Module - 168 Contacts

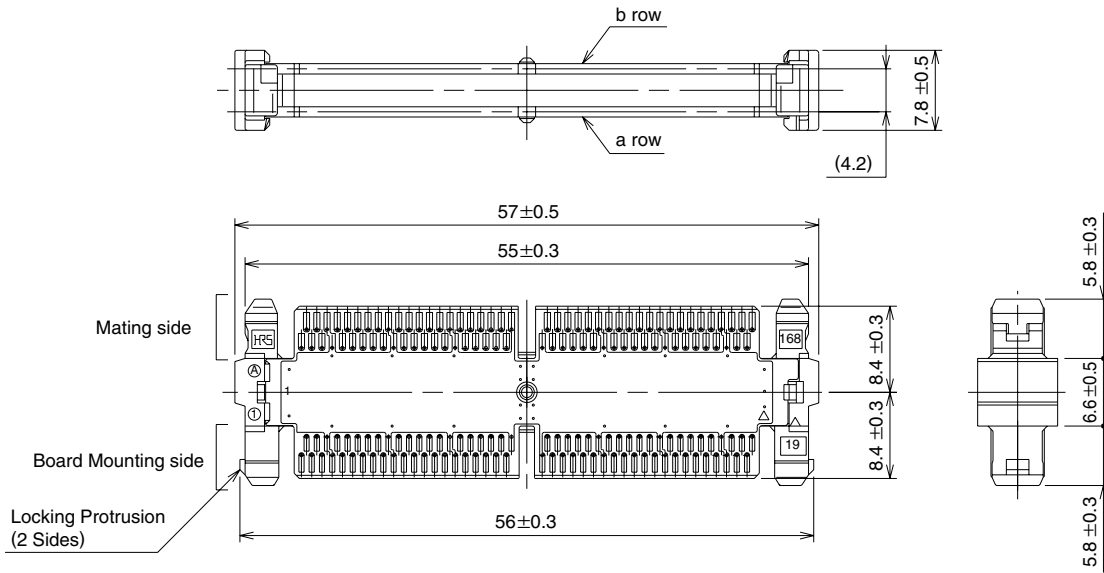

Part Number	CL No.	Board-to-board Distance	A	B	C	RoHS
IT1-168P/28-19H	641-0192-8	19mm	8.4	8.4	6.6	YES
IT1-168P/28-30H	641-0303-7	30mm	13.9	13.9	17.6	

## Connection Table

The connection table indicates contact numbers in the mated condition, as illustrated in Fig. 1.

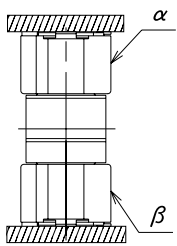

Fig. 1

		a row	
		α - β	α - β
Signal	a 1 - a84		a44 - a41
	a 2 - a83		
	a 3 - a82	Signal	
	a 4 - a81		
	a 5 - a80		a53 - a32
Ground	a 6 - a79	Ground	a54 - a31
	a 7 - a78		a55 - a30
Signal	a 8 - a77		a56 - a29
		Signal	
Ground	a17 - a68		a65 - a20
	a18 - a67	Ground	a66 - a19
Signal	a19 - a66		a67 - a18
	a20 - a65	Signal	a68 - a17
Ground	a29 - a56		a77 - a 8
	a30 - a55	Ground	a78 - a 7
Signal	a31 - a54		a79 - a 6
	a32 - a53	Signal	a80 - a 5
			a81 - a 4
			a82 - a 3
Ground	a41 - a44		a83 - a 2
	a42 - a43		a84 - a 1
Ground	a43 - a42		

		b row	
		α - β	α - β
Signal	b 1 - b84		b44 - b41
	b 2 - b83		
	b 3 - b82	Signal	
	b 4 - b81		
	b 5 - b80		b53 - b32
Ground	b 6 - b79	Ground	b54 - b31
	b 7 - b78		b55 - b30
Signal	b 8 - b77		b56 - b29
		Signal	
Ground	b17 - b68		b65 - b20
	b18 - b67	Ground	b66 - b19
Signal	b19 - b66		b67 - b18
	b20 - b65	Signal	b68 - b17
Ground	b29 - b56		b77 - b 8
	b30 - b55	Ground	b78 - b 7
Signal	b31 - b54		b79 - b 6
	b32 - b53	Signal	b80 - b 5
			b81 - b 4
			b82 - b 3
Ground	b41 - b44		b83 - b 2
	b42 - b43		b84 - b 1
Ground	b43 - b42		

## Transmission Module - 252 Contacts

### 2-row type

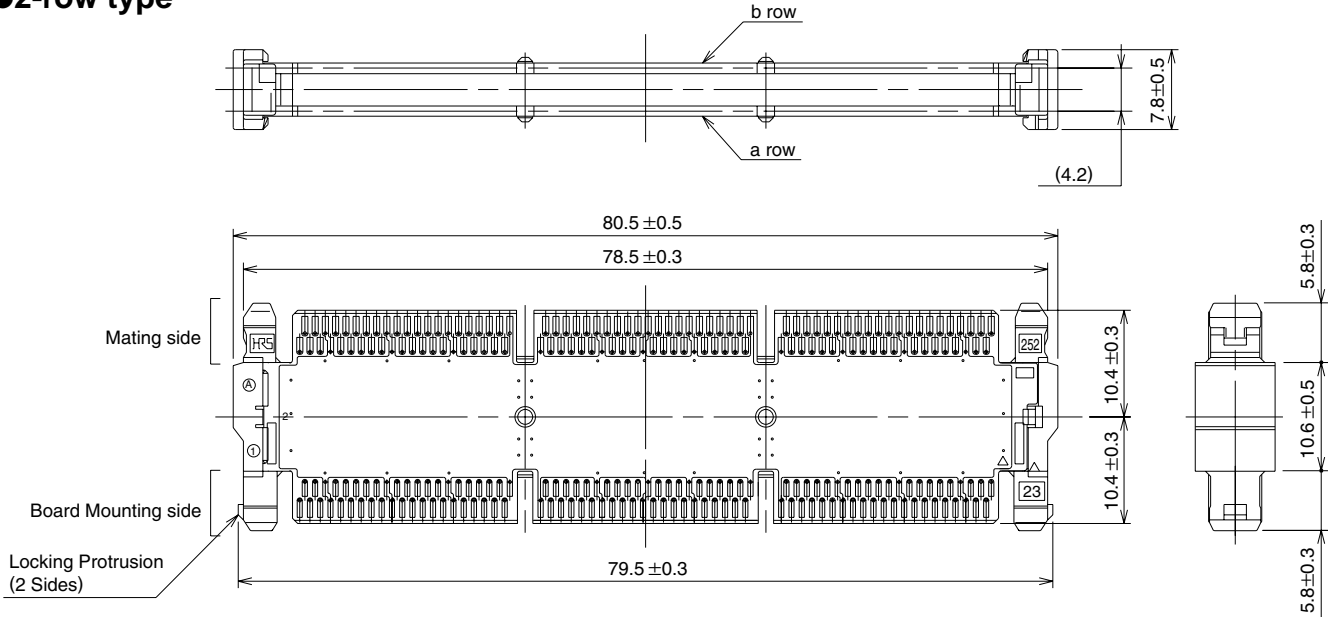

Part Number	CL No.	Board-to-board Distance	A	B	C	RoHS
IT1-252P/44-23H	641-0231-8	23mm	10.4	10.4	10.6	YES
IT1-252P/44-30H	641-0304-0	30mm	13.9	13.9	17.6	

## Connection Table

The connection table indicates contact numbers in the mated condition, as illustrated in Fig. 1.

Fig. 1: Cross-section diagram of the connector showing the a and b rows and the alpha-beta contact numbering system. The diagram shows two rows of contacts, labeled 'a' and 'b', with a central ground plane. The contact numbering is indicated by Greek letters alpha and beta.

a row				b row			
	$\alpha - \beta$		$\alpha - \beta$		$\alpha - \beta$		$\alpha - \beta$
Signal	a 1 - a126	Signal	a44 - a83	Signal	a86 - a41	Signal	b 1 - b126
	a 5 - a122		a53 - a74		a95 - a32		b 5 - b122
Ground	a 6 - a121	Ground	a54 - a73	Ground	a96 - a31	Ground	b 6 - b121
	a 7 - a120		a55 - a72		a97 - a30		b 7 - b120
Signal	a 8 - a119	Signal	a56 - a71	Signal	a98 - a29	Signal	b 8 - b119
	a17 - a110		a62 - a65		a107 - a20		b17 - b110
Ground	a18 - a109	Ground	a63 - a64	Ground	a108 - a19	Ground	b18 - b109
	a19 - a108		a64 - a63		a109 - a18		b19 - b108
Signal	a20 - a107	Signal	a65 - a62	Signal	a110 - a17	Signal	b20 - b107
	a29 - a98		a71 - a56		a119 - a 8		b29 - b98
Ground	a30 - a97	Ground	a72 - a55	Ground	a120 - a 7	Ground	b30 - b97
	a31 - a96		a73 - a54		a121 - a 6		b31 - b96
Signal	a32 - a95	Signal	a74 - a53	Signal	a122 - a 5	Signal	b32 - b95
	a41 - a86		a83 - a44		a126 - a 1		b41 - b86
Ground	a42 - a85	Ground	a84 - a43				b42 - b85
	a43 - a84		a85 - a42				b43 - b84
							b44 - b83
							b53 - b74
							b54 - b73
							b55 - b72
							b56 - b71
							b62 - b65
							b63 - b64
							b64 - b63
							b65 - b62
							b71 - b56
							b72 - b55
							b73 - b54
							b74 - b53
							b83 - b44
							b84 - b43
							b85 - b42
							b86 - b41
							b95 - b32
							b96 - b31
							b97 - b30
							b98 - b29
							b107 - b20
							b108 - b19
							b109 - b18
							b110 - b17
							b119 - b 8
							b120 - b 7
							b121 - b 6
							b122 - b 5
							b126 - b 1

IT1 Series High Speed, Matched Impedance, Parallel Board-to-Board Connector System

◆IT1 Series Extraction Tool

Part Number	CL No.	Remarks	RoHS
IT1-PICKER(1)	641-1001-3	2-piece Package	YES

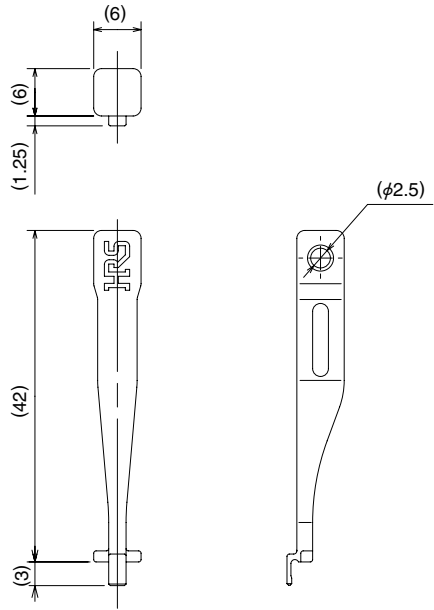

# Installation and Use Instruction Manual

## Table of Contents

<b>1. System Components</b> .....	A302
• Receptacles	
• Transmission Module Assembly	
• Extraction Tool	
<b>2. Recommended Design Guidelines</b> .....	A303
2-1 Recommended Solder Land Pattern	
2-2 Board-to-Board Spacer Heights	
<b>3. Connector Placement</b> .....	A304
3-1 Receptacle Packaging Types	
3-2 Receptacle Vacuum Pick-and-Place Areas	
3-3 Receptacle Board Placement	
3-4 Recommended Reflow Conditions	
3-5 Solder Repairs	
<b>4. Mating Procedure</b> .....	A307
<b>5. Un-mating of Connectors</b> .....	A308
<b>6. Removal of the Transmission Module from the stationary side.</b> ..	A309
<b>7. Precautions When Mounting Multiple Connectors</b> ..	A310
• Allowable Amount of Misalignment	
• Recommended Positional Location	



## ◆ Connector Handling Precautions

### 1. System components

#### ■ Receptacles

- **Contacts**  
Row A and row B contacts are arranged alternately starting with No.1 in row B. Placement on board is polarized.
- **Metal Fittings**  
Permanently inserted to provide lock with the Transmission Module and additional solder areas with the PCB.
- **Insulator body**  
Injection molded single unit provides protection and correct self-alignment of all components.

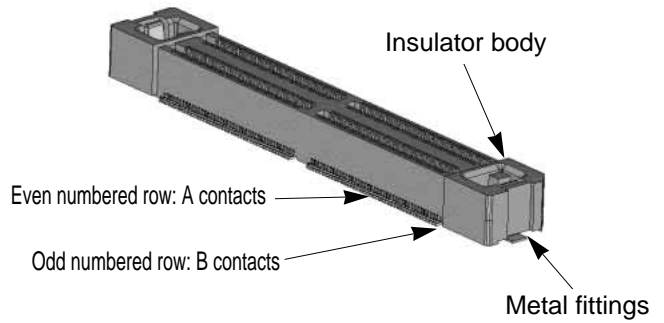

#### ■ Transmission Module Assembly

- Each Module has stationary side and a mating/un-mating side.
- When mounting multiple connectors, please keep uniform orientation of the stationary side.
- Transmission printed circuit boards used in the module are based on JIS standards and quality standards applicable to memory modules.

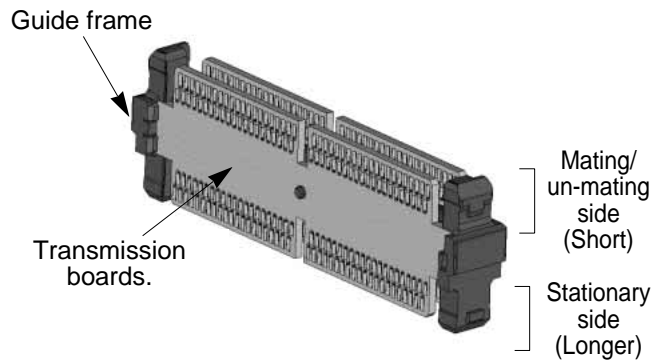

#### ■ Extraction Tool

- Used to release the transmission module from the stationary receptacle.

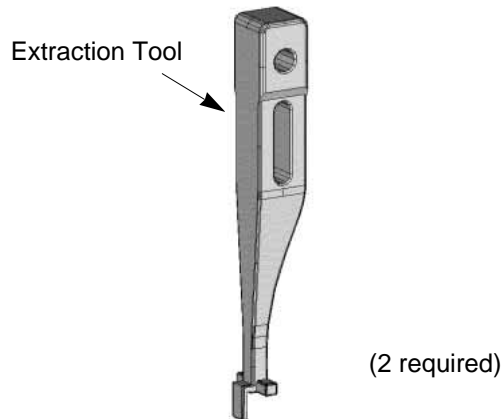

## Fully Connected Condition

The interconnection package consists of 3 main sub-assemblies: Two receptacles and the Transmission Module. The transmission module, held securely by the guide frame has a mating/un-mating side and a stationary side. Once the stationary side is inserted in the receptacle, it can not be removed without the use of extraction tool. The mating/un-mating side allows repeated re-insertion of the receptacle on this side only.

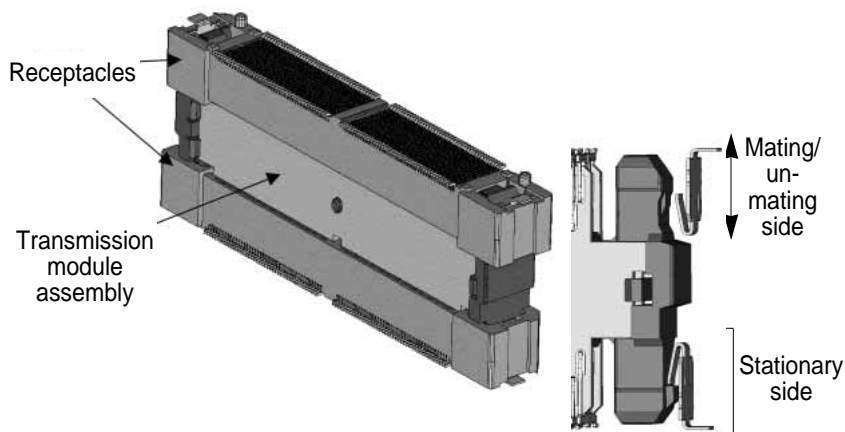

## 2. Recommended Design Guidelines

### 2-1 Solder Land Pattern

When placing the receptacles on the Printed Circuit Boards using automatic mounting equipment or manually, assure that the correct diameters of the holes (Fig. 1) are through the entire thickness of the board.

#### ◆ Locating post hole diameter ◆

The contacts of receptacle assembly are exposed on the bottom surfaces. The exposed areas of the contacts are a distance of 0.25 mm minimum from the surface of the Printed Circuit Board, on which the receptacle assembly is placed (Fig.2). Consideration should be taken not to place or assure insulation of conductive traces under the receptacle assemblies.

Refer to the separate drawings for recommended solder land pattern dimensions of the receptacle, and signals and ground connection diagram of the transmission module.

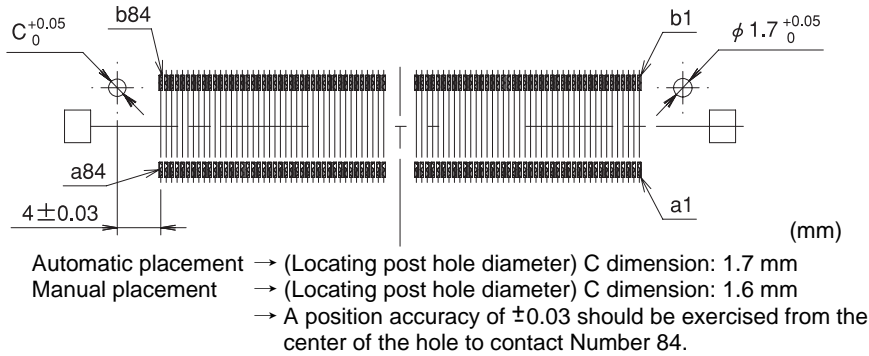

Fig. 1 IT1-168S-SV Recommended Solder Land Pattern

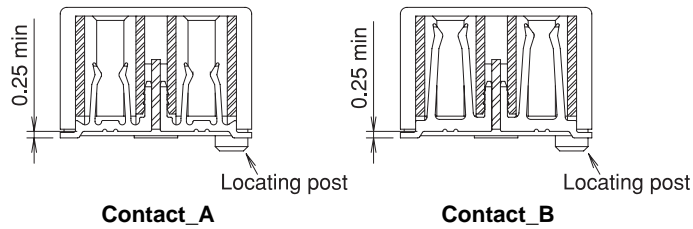

Fig. 2 Cross section of IT1 receptacle

### 2-2 Board-to-Board Spacer heights

The two parallel boards connected by the IT1 connectors should be fastened to additional spacers between them.

Fig. 3 indicates the connector height tolerance and the spacer's height.

When designing the spacer's height, consideration should be given to the solder paste thickness and any other features, which may affect the full mating of the connector.

Fig. 3 indicates design dimensions for the 19 mm board-to-board distance.

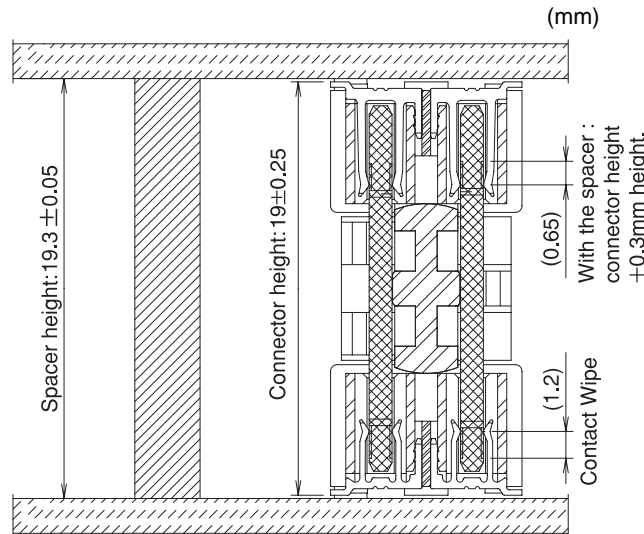

Fig. 3

**IT1 Series High Speed, Matched Impedance, Parallel Board-to-board Connector System**

**3. Connector Placement**

**3-1 Packaging Types**

- Two types of packaging are available: semi-hard tray and hard tray. Customers may specify a packaging type suitable for their automatic placement machines.
- \* Refer to the separate drawings for the detailed dimensions of the trays.

**• Semi-hard tray packaging**

168 contacts receptacle: 40 pieces per tray  
 252 contacts receptacle: 30 pieces per tray

**• Hard tray packaging**

168 contacts receptacle: 24 pieces per tray  
 252 contacts receptacle: 16 pieces per tray

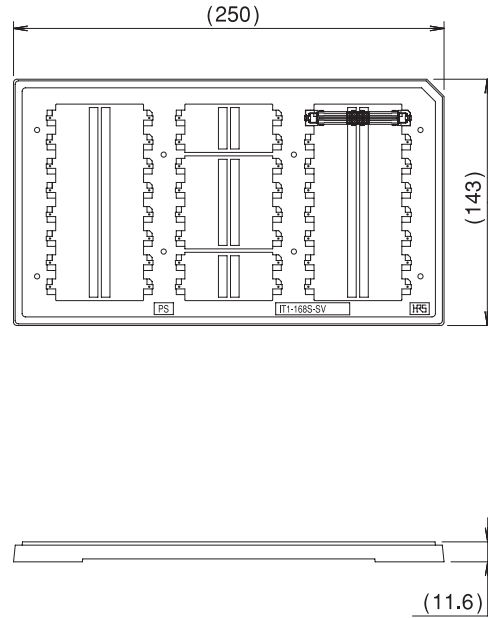
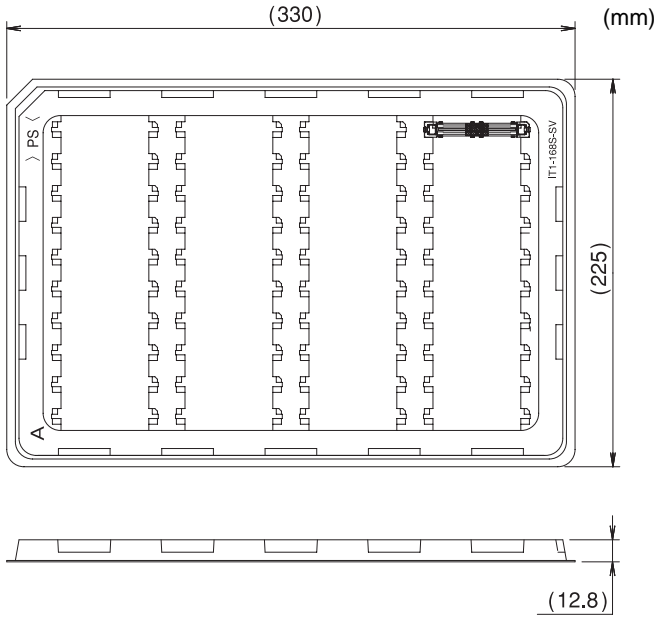

**3-2 Automatic placement - Vacuum Pick-and-Place Areas**

- Specify "Vacuum Pick-up Tape Specification".  
 The area and position of the pick-and-place surface are indicated in the diagrams below.

**• 168 contacts**

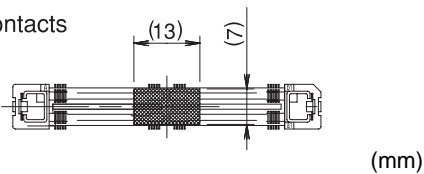

**• 252 contacts**

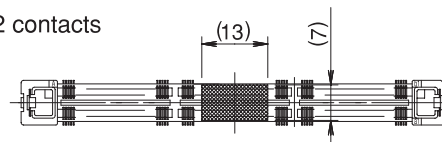

### 3-3 Receptacle Board Placement

- When using automatic placement equipment, verify the packaging type and the Pick-and-place areas.
- When placing manually, pay attention to the possibility of positional shift. Ref. Fig. 4.
- \* When placing multiple connectors, to assure positional accuracy, it is advised to use automatic placement equipment.

#### ◆ Precautions for Manual Placement ◆

The orientation posts serve as a prevention measure to avoid incorrect placement of the receptacle assemblies on the board. The contact terminals must be placed correctly over the corresponding solder pad as shown on Fig. 4-1.

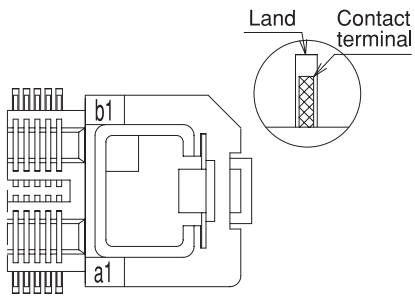

Fig. 4-1 = Correct

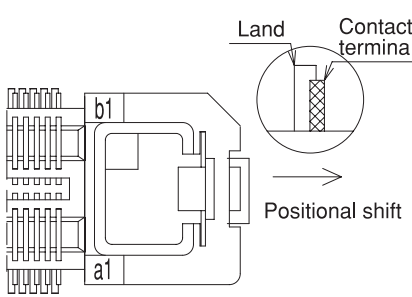

Fig. 4-2 = Incorrect

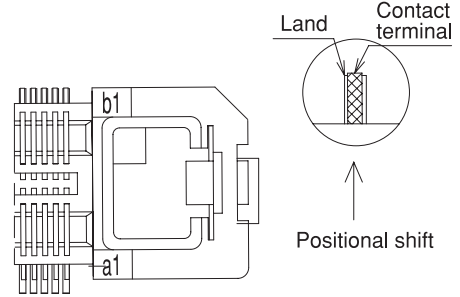
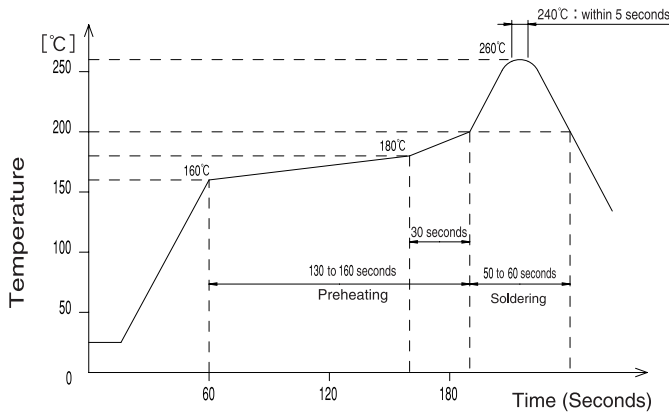

Fig. 4-3 = Incorrect

### 3-4 Recommended Reflow Conditions



#### Applicable Conditions

- Reflow system : IR reflow
- Solder : Paste type (Sn:96.5, AG:3.0, Cu:5.0)  
(Flux content 9wt%)
- Test board : Glass epoxy (FR-4), 85mm x 110mm x 1.6 mm
- Metal mask thickness : 0.15 mm

\* Shown recommended temperature profile.

### 3-5 Solder Repairs

Assure that flux is not reaching the contact areas of the connector.  
Wash the assembly as recommended below.

#### ◆Cleaning Conditions◆

<Organic Solvent Cleaning>

Solvent Type	Normal temperature	Heated
IPA (Isopropyl alcohol)	Good	Good

<Water Based Cleaning>

When using water based cleaning agents (e.g., terpene, and alkali saponifiers), select the cleaning agent based on the documentation issued by the various manufacturers, which describes its effects on metals and resins. Care should be taken not to leave moisture on the connectors.

<Cleaning Precautions>

Residual flux or cleaning agent remaining on the connectors when cleaning with organic solvents or water based cleaners may cause deterioration of the electrical performance. It is important to check that a thorough washing has been performed.

## 4. Mating Procedure

Follow the procedure described below.

- Note:
- The transmission module must be fully inserted into receptacle assembly already placed and soldered to a board.
  - The Transmission Module cannot be exposed to heat temperatures of the soldering process.

### Step 1

Receptacle Placement on the board – stationary side

Assure that the orientation posts are aligned with the holes on the board.

When specifying receptacle assemblies without the orientation posts exercise extra caution to assure correct orientation and connection with the solder pads.

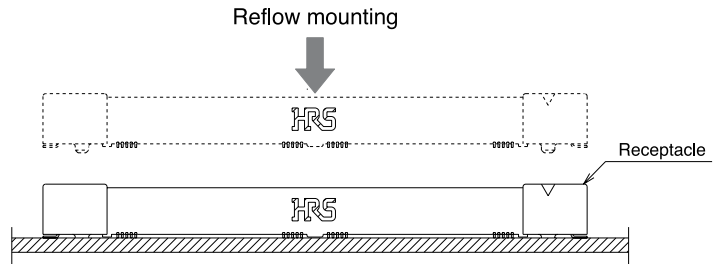

### Step 2

Insertion of the Transmission Module

Fully insert the Transmission Module in the board-installed receptacle assembly.

It is critical that the insertion is done straight and uniformly.

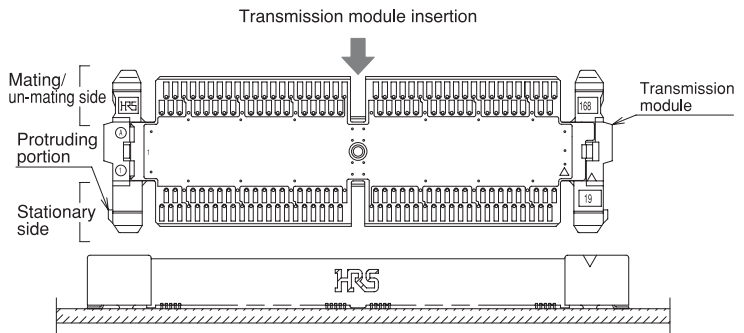

### Step 3

Mating/un-mating

Assure that the receptacle assembly is correctly aligned with the Transmission Module.

Fully insert the receptacle assembly on the Transmission Module.

It is critical that the insertion is done straight and uniformly.

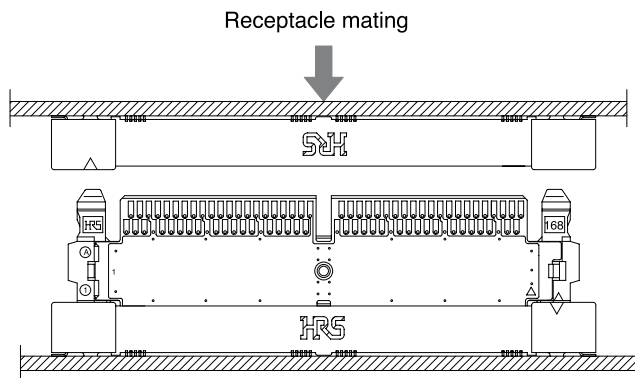

### Step 4

Connection completed

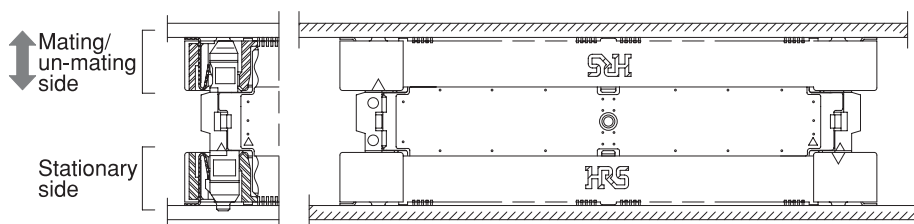

## HM Series High Speed, Matched Impedance, Parallel Board-to-Board Connector System

### 5. Un-mating of Connectors

#### Recommended Method

- Pull uniformly straight up.

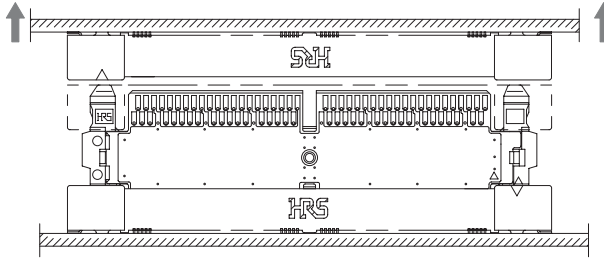

#### Prohibited un-mating Methods

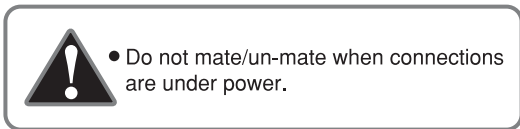
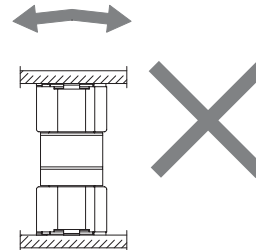
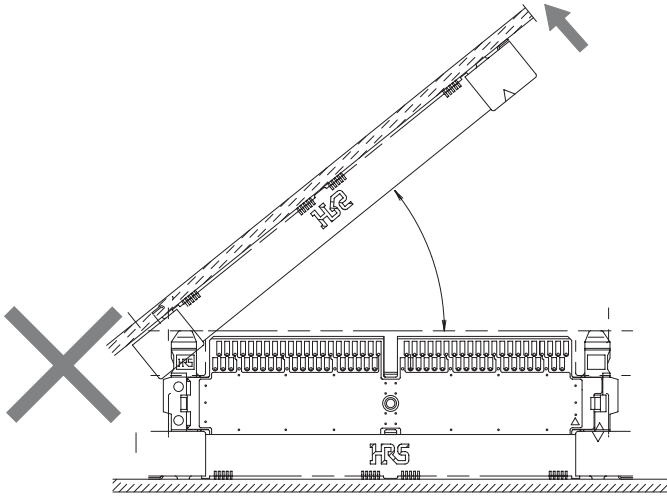
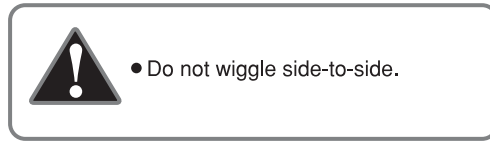
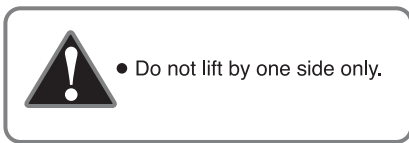

## 6. Removal of the Transmission Module - stationary side

- Requires use of dedicated extraction tool. Two are required.

### Step 1

- Fully insert the tools into each end of the receptacle assembly (Fig. 1) assuring that they will be over the hold areas of the Transmission Module frame. Ref. Fig. 2

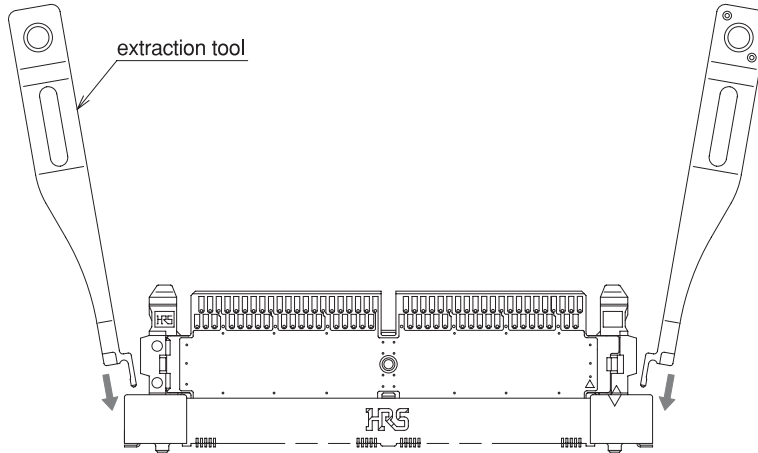

Fig. 1

### Step 2

- Pull out the transmission module holding the tools straight.

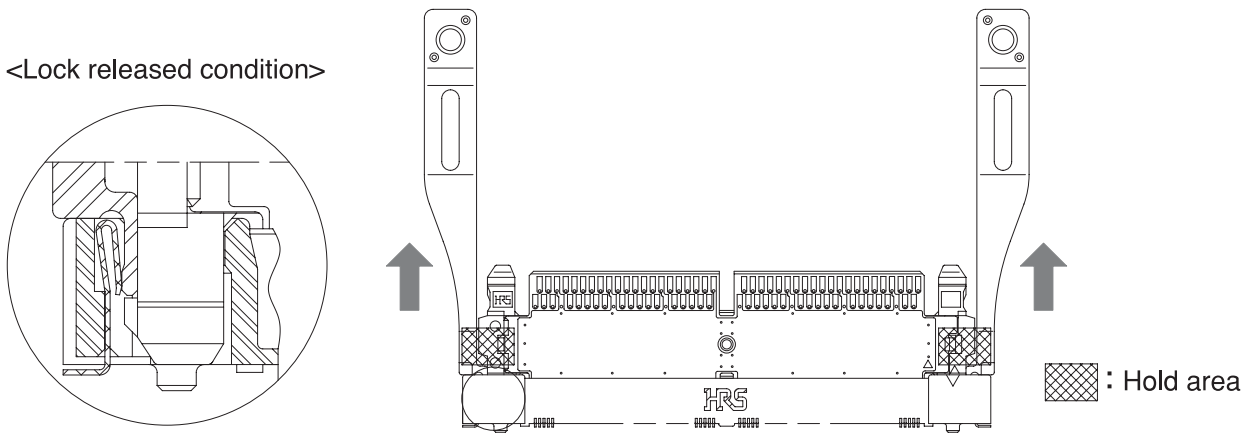
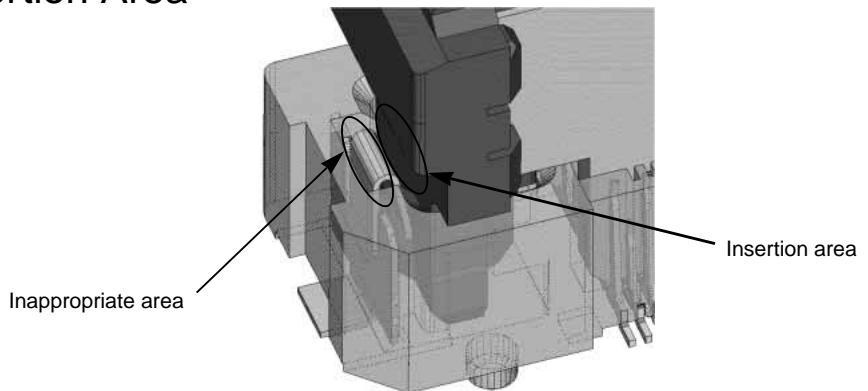

Fig. 2

### extraction tool Insertion Area





**H1 Series High Speed, Matched Impedance, Parallel Board-to-Board Connector System**

**7. Precautions When Mounting Multiple Connectors**

Note: Observe the requirements as listed in paragraph 7-1 and 7-2.

The mating/un-mating forces will increase with use of multiple assemblies. It is recommended that a dedicated tooling is used for mating / un-mating of multiple connector assemblies in a single operation.

**7-1 Allowable Amount of Misalignment**

Maximum allowable misalignment in X and Y directions is  $\pm 0.2$  mm total.  
 Refer to the drawings below.

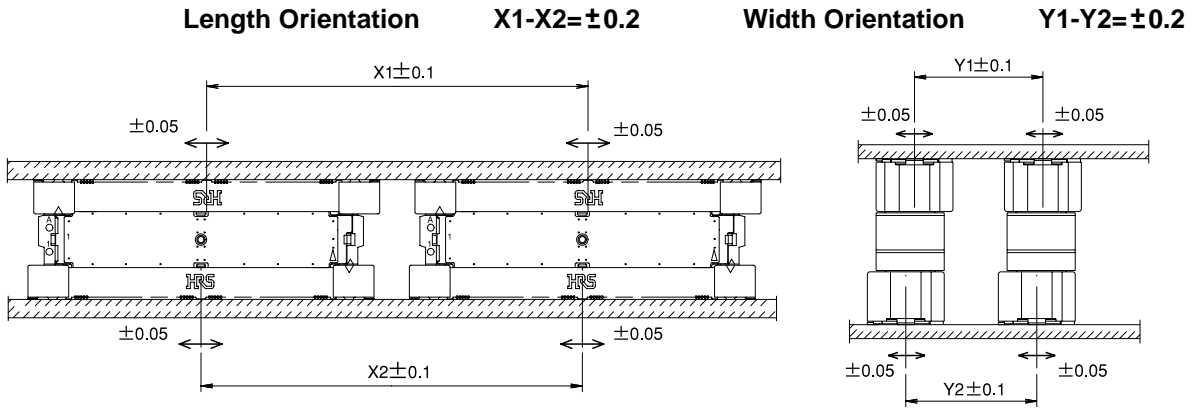

**7-2 Recommended Connector Placement**

It is recommended to leave min. of 30 mm space between the adjacent connector assemblies.

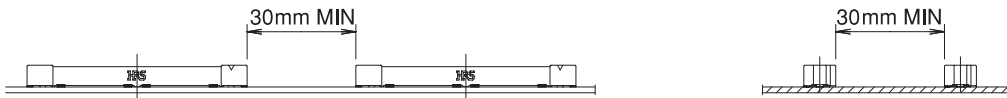

**7-3 Examples of Prohibited Placement Positions**

To assure reliability of solder joints and mating/ un-mating without damage, **DO NOT PLACE MULTIPLE CONNECTORS** as illustrated below.

