

PART NUMBER: CMC-2742WBL-25L

DESCRIPTION: electret condenser microphone

SPECIFICATIONS

directivity	omnidirectional	
sensitivity (S)	-42 ±3 db	f = 1KHz, 1Pa 0dB = 1V/Pa
sensitivity reduction (ΔS-Vs)	-3 dB	f = 1KHz, 1Pa Vs = 2.0 ~ 1.5 V dc
operating voltage	2 V dc (standard), 10 V dc (max.)	
output impedance (Zout)	2.2 KΩ	f = 1KHz, 1Pa
operating frequency (f)	100 ~ 20,000 Hz	
current consumption (IDSS)	0.5 mA max.	Vs = 2.0 V dc RL = 2.2KΩ
signal to noise ratio (S/N)	57 dBA	f = 1KHz, 1Pa A-weighted
operating temperature	-20 ~ +70° C	
storage temperature	-20 ~ +70° C	
dimensions	ø6.0 x 2.7 mm	
weight	0.22 g max.	
material	Al	
terminal	wire type (hand soldering only)	
RoHS	yes	
dustproof and waterproof level	IP57	

note: We use the "Pascal (Pa)" indication of sensitivity as per the recommendation of I.E.C. (International Electrotechnical Commission). The sensitivity of "Pa" will increase 20dB compared to the "ubar" indication. Example: -60dB (0dB = 1V/ubar) = -40dB (1V/Pa)

APPEARANCE DRAWING

tolerances not shown: ±0.3mm

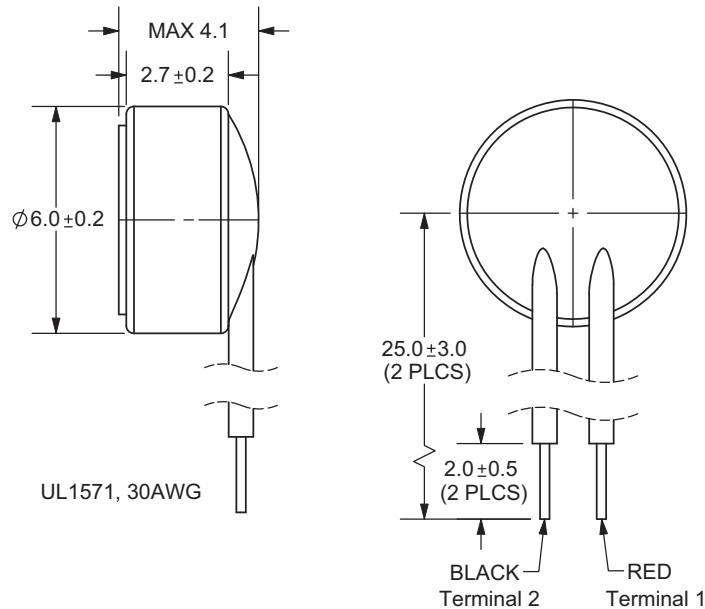

PART NUMBER: CMC-2742WBL-25L

DESCRIPTION: electret condenser microphone

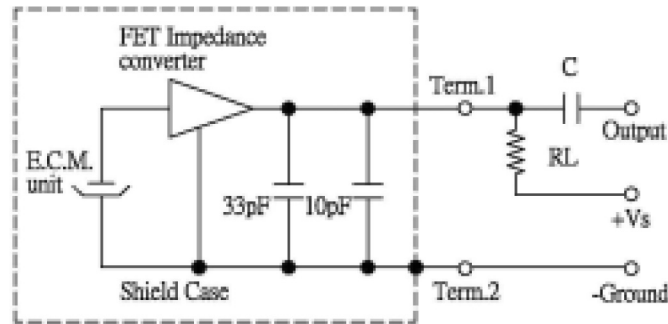
MEASUREMENT CIRCUIT
 $RL = 2.2K\Omega$

Schematic Diagram

FREQUENCY RESPONSE CURVE

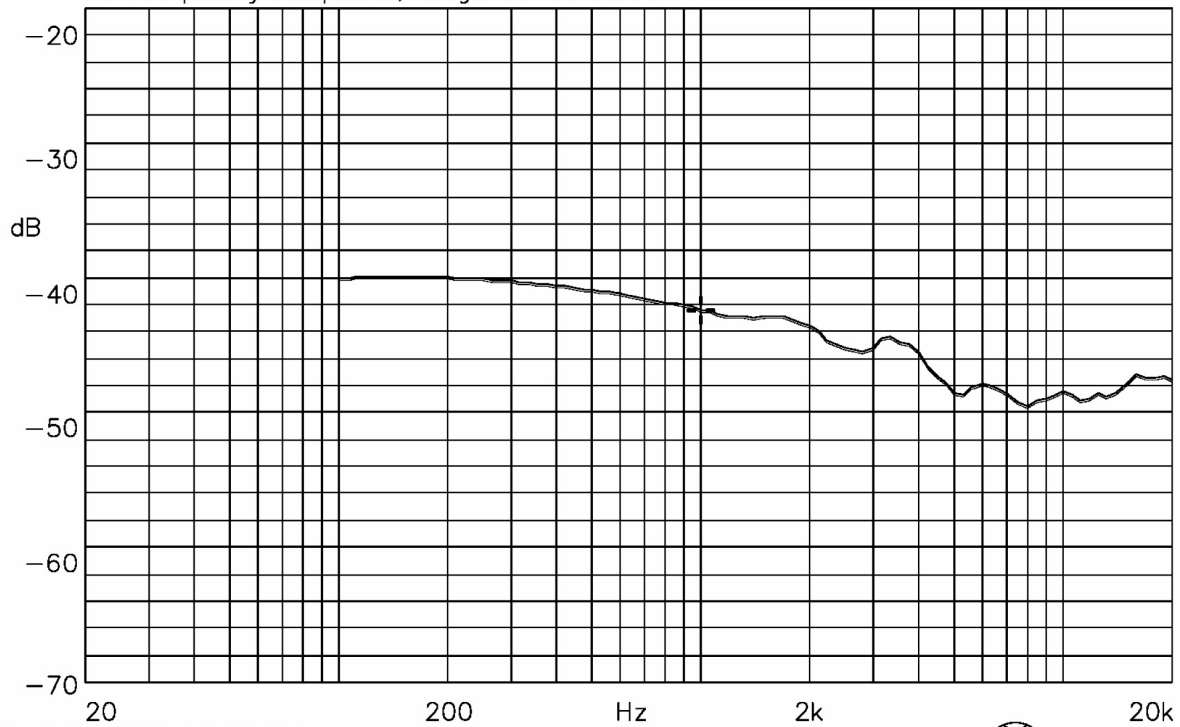
 X: 1.0000kHz Y: -42.36dB ZA: Live Curve SSR Fund.
 A: Frequency Response, Magn dB re 1.000

9-JAN-2008 14:35:07

lode: SSR



PART NUMBER: CMC-2742WBL-25L

DESCRIPTION: electret condenser microphone

MECHANICAL CHARACTERISTICS

item	test condition	evaluation standard
solderability (connector excepted)	Stripped wires of lead wires are immersed in rosin for 5 seconds and then immersed in a solder bath of $270 \pm 5^\circ\text{C}$ for 3 ± 0.5 seconds.	90% min. stripped wires will be wet with solder. (except the edge of the terminal)
lead wire pull strength	The pull force will be applied to double lead wire: Horizontal 4.9N (0.5kg) for 30 seconds	No damage or cutting off.
vibration	The part will be measured after applying a vibration amplitude of 1.5 mm with 10 to 55 Hz band of vibration frequency to each of the 3 perpendicular directions for 2 hours.	After any tests, the sensitivity should be within $\pm 3\text{dB}$ compared to the initial measurement.
drop test	The part will be dropped from a height of 1 m onto a 20 mm thick wooden board 3 times in 3 axes (X, Y, Z) for a total of 9 drops.	

ENVIRONMENT TEST

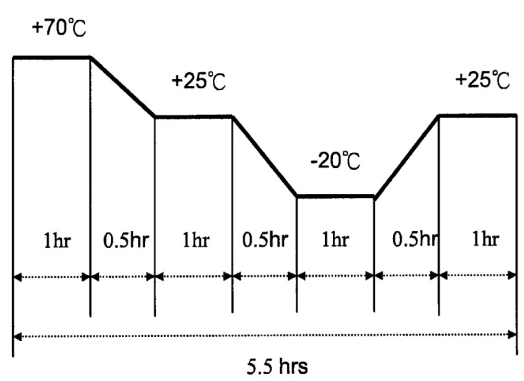
item	test condition	evaluation standard
high temp. test	After being placed in a chamber at $+70^\circ\text{C}$ for 72 hours.	The part will be measured after being placed at $+25^\circ\text{C}$ for 6 hours. After any tests, the sensitivity should be within $\pm 3\text{dB}$ compared to the initial measurement.
low temp. test	After being placed in a chamber at -20°C for 72 hours.	
humidity test	After being placed in a chamber at $+40^\circ\text{C}$ and $90 \pm 5\%$ relative humidity for 240 hours.	
temp. cycle test	The part shall be subjected to 10 cycles. One cycle will consist of: 	

TEST CONDITIONS

standard test condition	a) temperature: $+5 \sim +35^\circ\text{C}$	b) humidity: 45 - 85%	c) pressure: 860-1060 mbar
judgement test condition	a) temperature: $+25 \pm 2^\circ\text{C}$	b) humidity: 60 - 70%	c) pressure: 860-1060 mbar

PART NUMBER: CMC-2742WBL-25L

DESCRIPTION: electret condenser microphone

PACKAGING

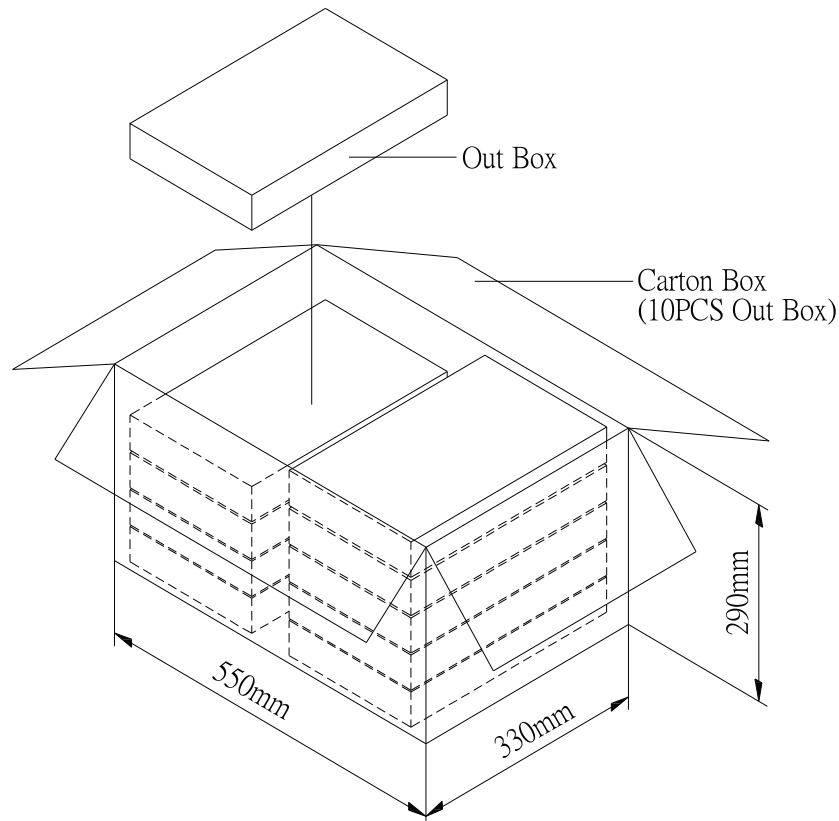
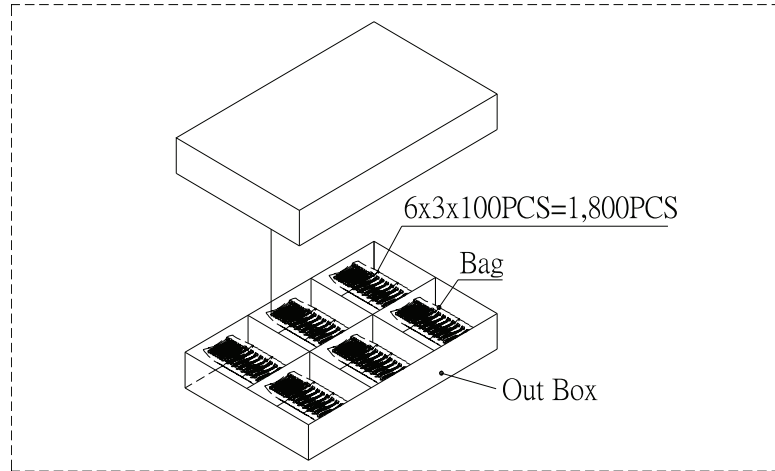

Out Box	310mmx248mmx49mm	1x1,800PCS=1,800PCS
Carton Box	550mmx330mmx290mm	1,800PCSx10=18,000PCS