



LBS06004 MHz SAW Filter Electrical Characteristic

Specifications

Parameter	Unit	Minimum	Typical	Maximum
Center Frequency	MHz	59.987	60	60.013
Insertion Loss	dB		16.31	20
1 dB Bandwidth	MHz	-	0.125	
3 dB Bandwidth	MHz	0.226	0.234	
45 dB Bandwidth	MHz		0.745	0.8
Passband variation	dB		0.05	0.2
Ultimate Rejection	dB	45	50	
Absolute Delay	usec		3.77	
Substrate Material		Quartz		
Ambient Temperature	°C	25		
Package Size	DIP3616 (36.0x16.0x5.0mm ³)			

Typical Performance

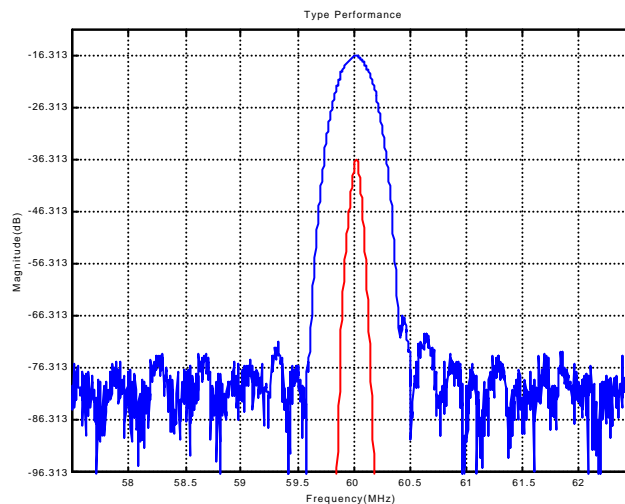

Package Outline

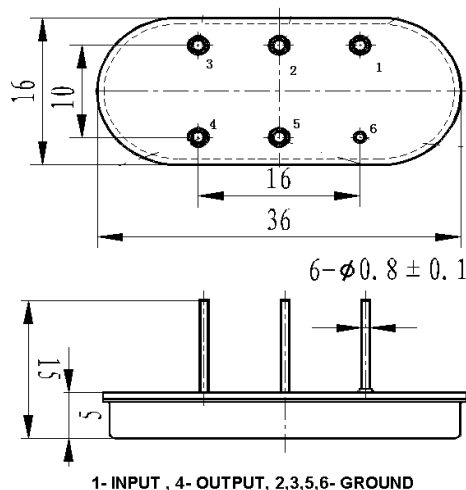

Matching Configuration

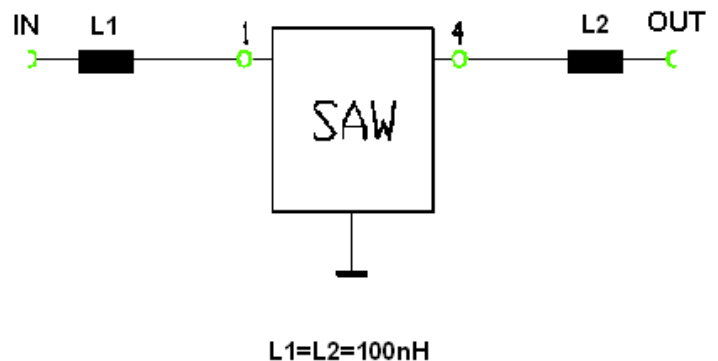

Source/Load Impedance = 50 ohm