

11-MD127

Version : A.008
Issue Date : 2006/08/31
File Name : SP-MD127-A.008.doc
Total Pages : 10

Low-saturation, Low-voltage
2 Channels Bi-directional Motor Driver



新竹市展業一路9號7樓之1

SILICON TOUCH TECHNOLOGY INC.

9-7F-1, Prosperity Rd I, Science-Based Industrial Park

Hsinchu, Taiwan, R.O.C.

Tel : 886-3-5645656 Fax : 886-3-5645626

11-MD127

Low-saturation, Low-voltage 2 Channels Bi-directional Motor Driver

General Specifications

The device is a two-channel low-saturation bi-directional motor driver IC. The design is optimal for 2-dc motor or stepper-motor applications, such as driving shutter/iris on cameras and other motor applications on portable devices.

Features and Benefits

- Low voltage operation ($V_{DD\ min} = 2.0V$)
- Low saturation voltage
(Upper transistor + low transistor residual voltage; 0.46V typ. at 400mA)
- Low input current
- Low operating current
- High output sinking and driving capability
- Ultra-small, thin, highly reliable package (WLCSP, MSOP-10 and DFN-10)
- Thermal shutdown protection

Pin Assignment

MSOP-10

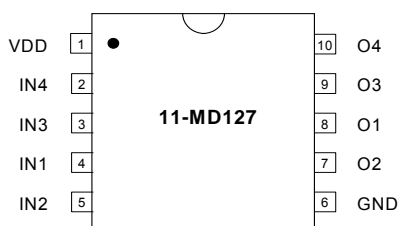

DFN-10

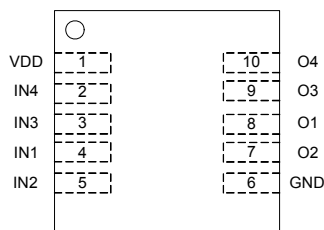

PIN NO.	PIN NAME	DESCRIPTION
1	VDD	Power supply pin
2	IN4	Input pin that determines driving mode.
3	IN3	Input pin that determines driving mode.
4	IN1	Input pin that determines driving mode.
5	IN2	Input pin that determines driving mode.
6	GND	Ground pin
7	O2	Output sinking / driving pin
8	O1	Output sinking / driving pin
9	O3	Output sinking / driving pin
10	O4	Output sinking / driving pin.

WLCSP

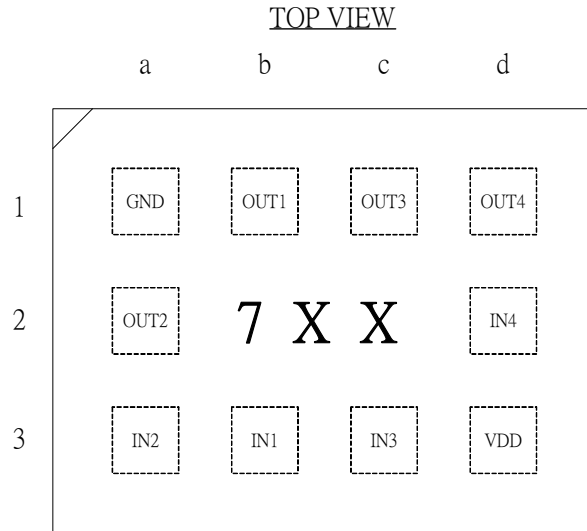

PIN NO.	PIN NAME	DESCRIPTION
a1	GND	Ground pin
a2	OUT2	Output sinking / driving pin
a3	IN2	Input pin that determines driving mode.
b1	OUT1	Output sinking / driving pin
b3	IN1	Input pin that determines driving mode.
c1	OUT3	Output sinking / driving pin
c3	IN3	Input pin that determines driving mode.
d1	OUT4	Output sinking / driving pin.
d2	IN4	Input pin that determines driving mode.
d3	VDD	Power supply pin

Absolute Maximum Ratings (Unless otherwise noted, $T_A = 25^\circ\text{C}$)

Characteristic	Symbol	Rating	Unit
Supply Voltage	V_{DD}	5.5	V
Input Voltage	V_{IN}	$V_{DD}+0.4$	V
Maximum Output Current/Channel (DFN,MSOP)	I_{OUT1}	400	mA
Maximum Output Current/Channel (WLCSP)	I_{OUT2}	250	mA
Power Dissipation (IC)	P_D	486	mW
Power Dissipation (PCB mounted)	P_{D-PCB}	870	
Operating Temperature Range	T_{OPR}	-40 ~ 125	$^\circ\text{C}$
Storage Temperature Range	T_{STG}	-65 ~ 150	$^\circ\text{C}$

Electrical Characteristic (Unless otherwise noted, $T_A = 25^\circ\text{C}$ & $V_{DD} = 3\text{V}$)

Characteristic	Sym.	Condition	Limit			Unit
			Min.	Typ.	Max.	
Supply Voltage	V_{DD}		2.0	3	5.5	V
Supply Current	I_{DD0}	$V_{IN1,IN2,IN3,IN4}=0\text{V}$		0.1	10	μA
	I_{DD1}	$V_{IN1,IN2,IN3,IN4} \neq 0\text{V}$		0.2	0.5	mA
IN 1 / IN 2 / IN3 / IN4 Input Terminal ($T_J = 25^\circ\text{C}$)						
Input Voltage "H"	V_{IH}	-	$0.5 \cdot V_{DD}$	-	$V_{DD}+0.4$	V
Input Voltage "L"	V_{IL}	-	-0.4	-	$0.2 \cdot V_{DD}$	V
Input Current "H"	I_{IH}	$V_{IN} = V_{DD}$	-	-	± 5	μA
Input Current "L"	I_{IL}	$V_{IN} = 0\text{V}$	-	-	± 5	μA
O1 / O2 / O3 / O4 Output Terminal ($T_J = 25^\circ\text{C}$)						
Output Voltage (upper + lower)	V_{OUT1}	$I_{OUT} = 100\text{mA}$	-	0.12	0.2	V
	V_{OUT2}	$I_{OUT} = 200\text{mA}$	-	0.28	0.4	V
	V_{OUT3}	$I_{OUT} = 400\text{mA}$	-	0.46	0.7	V
Thermal Protection Circuit						
Protection Temperature	T_{TSD}	$V_{IN1, IN2, IN3, IN4} = \text{H}$		150		$^\circ\text{C}$

Truth Table

IN1 / IN3	IN2 / IN4	O1 / O3	O2 / O4	Mode
L	L	OFF	OFF	Standby
H	L	H	L	Forward
L	H	L	H	Reverse
H	H	—	—	Keep the previous mode (Forward / Reverse)

Note: “—” indicates a “don’t care” input.

Block Diagram & Application Circuit

1. Shutter & Iris application

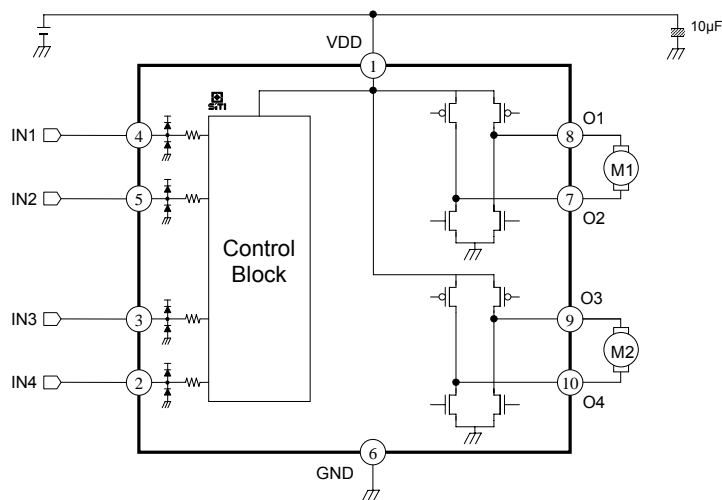

2. Stepping motor for 1-2 phase excitation

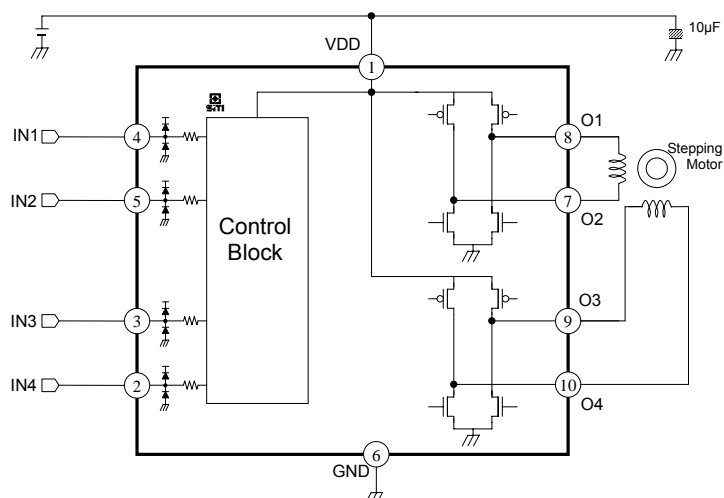



IN1	IN2	IN3	IN4	O1	O2	O3	O4	Notes
L	L	L	L	OFF	OFF	OFF	OFF	Standby
H	L	L	L	H	L	OFF	OFF	1-2 phase excitation
H	L	H	L	H	L	H	L	
L	L	H	L	OFF	OFF	H	L	
L	H	H	L	L	H	H	L	
L	H	L	L	L	H	OFF	OFF	
L	H	L	H	L	H	L	H	
L	L	L	H	OFF	OFF	L	H	
H	L	L	H	H	L	L	H	
H	H	-	-	Keep the previous output state				
-	-	H	H					

Note: “—” indicates a “don’t care” input.

Application Notes

- The power dissipated by the IC varies widely with the supply voltage, the output current, and loading. It is important to ensure the application does not exceed the allowable power dissipation of the IC package. The recommended motor driver power dissipation versus temperature is depicted as follows:

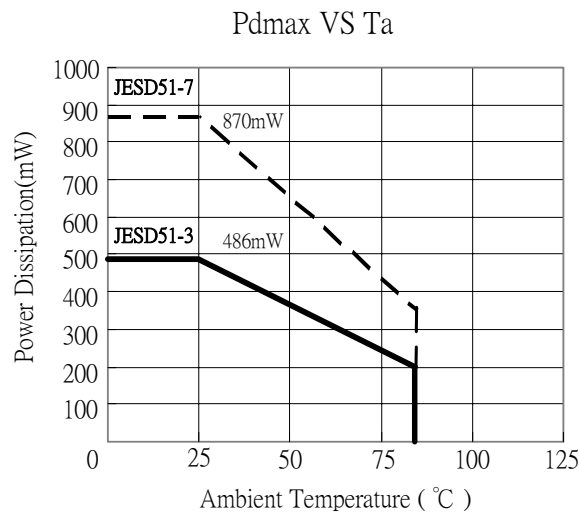

Typical Performance Curve

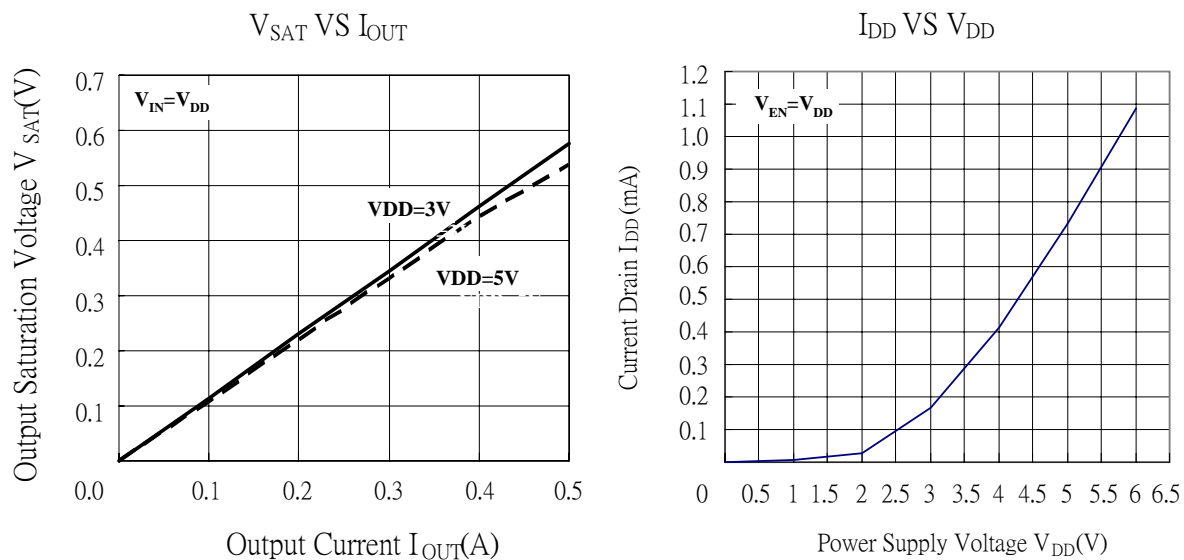

Package Specifications MSOP-10

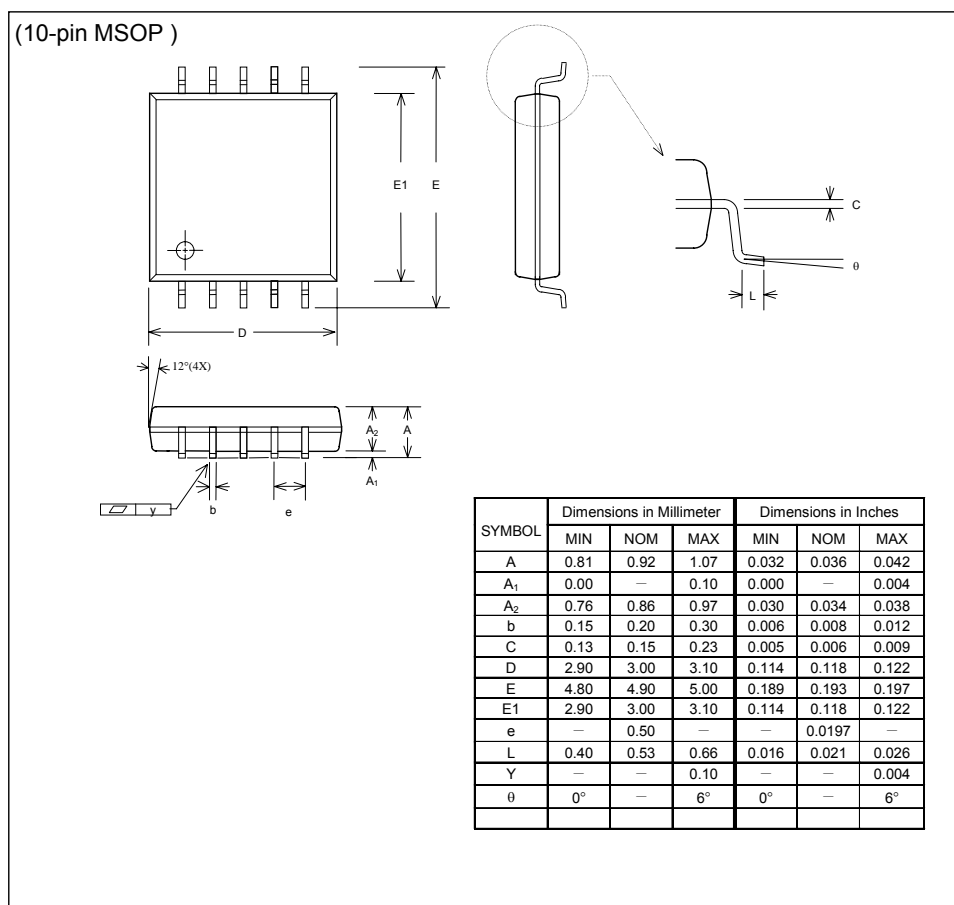



DFN-10

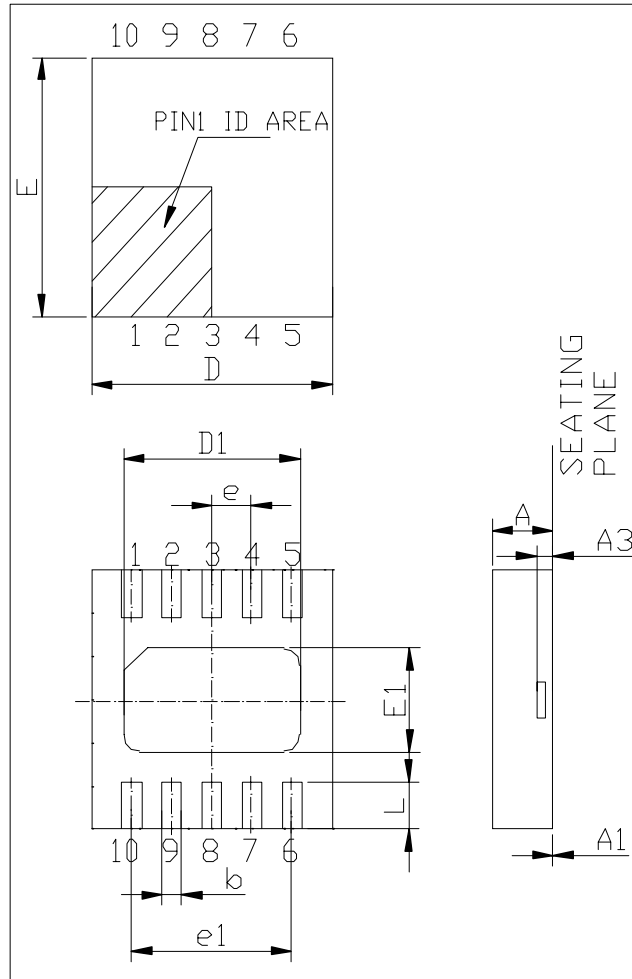

SYMBOL	DIMENSION (mm)			DIMENSION (mil)		
	MIN.	NOM.	MAX.	MIN.	NOM.	MAX.
A	0.70	0.75	0.80	28	30	32
A1	0.00	0.02	0.05	0	0.8	2
A3	0.203 REF			8 REF		
b	0.18	0.25	0.30	7	10	12
D	2.90	3.00	3.10	114	118	122
D1	2.10	2.20	2.30	83	87	91
E	2.90	3.00	3.10	114	118	122
E1	1.10	1.20	1.30	86	87	91
L	0.45	0.55	0.65	18	22	26
e	0.50 BASIC			20 BASIC		
e1	2.00 BASIC			79 BASIC		

WLCSP

BOTTOM VIEW

(Ball side)

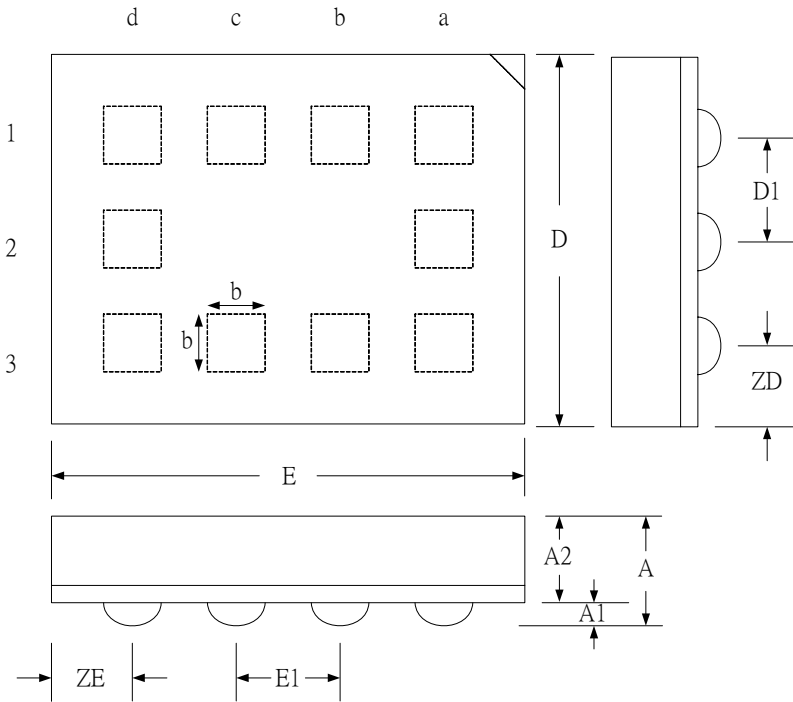

TOP VIEW

(Marking side)

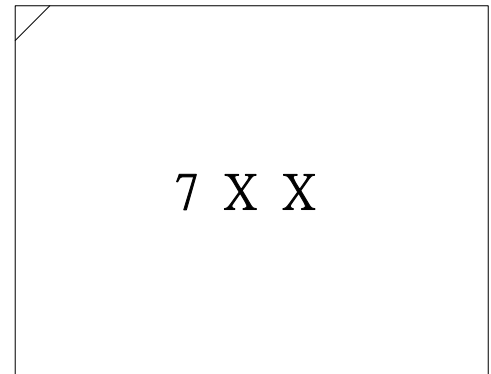

XX is the run code.

SYMBOL	DIMENSION (mm)		
	MIN.	NOM.	MAX.
A	0.45	0.50	0.55
A1	0.08	0.10	0.12
A2	0.37	0.40	0.43
b	0.26	0.28	0.30
D	1.40	1.50	1.60
D1	0.50		
E	1.90	2.00	2.10
E1	0.50		
ZD	0.25		
ZE	0.25		



The products listed herein are designed for ordinary electronic applications, such as electrical appliances, audio-visual equipment, communications devices and so on. Hence, it is advisable that the devices should not be used in medical instruments, surgical implants, aerospace machinery, nuclear power control systems, disaster/crime-prevention equipment and the like. Misusing those products may directly or indirectly endanger human life, or cause injury and property loss.

Silicon Touch Technology, Inc. will not take any responsibilities regarding the misuse of the products mentioned above. Anyone who purchases any products described herein with the above-mentioned intention or with such misused applications should accept full responsibility and indemnify. Silicon Touch Technology, Inc. and its distributors and all their officers and employees shall defend jointly and severally against any and all claims and litigation and all damages, cost and expenses associated with such intention and manipulation.