

## 20mm Diameter, Single-Turn, Carbon Industrial Panel Controls

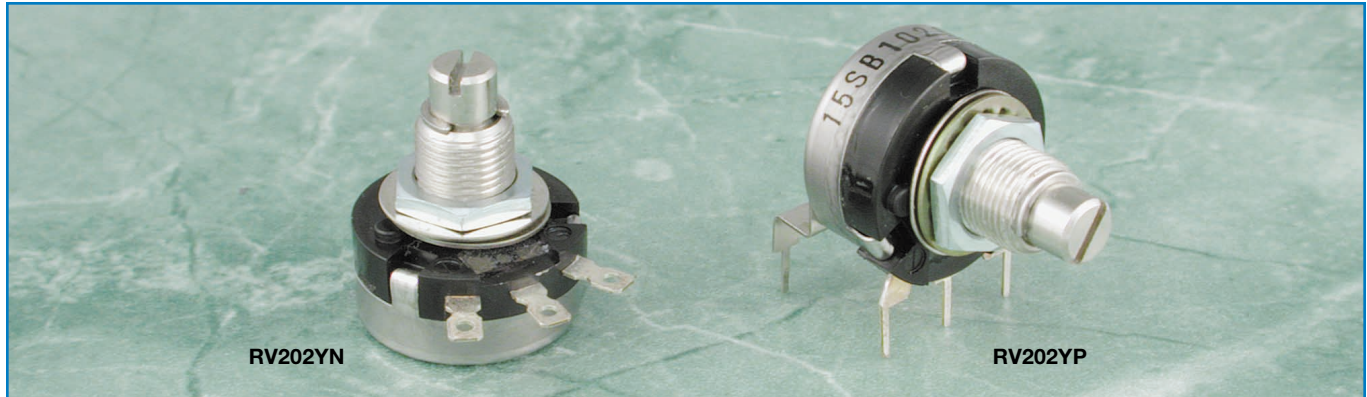

### Features

- 20mm diameter, single-turn industrial panel controls
- Carbon film element
- Single unit, single shaft
- Linear or audio tapers
- Available in right angle mounting styles only
- Metal shaft and bushing
- 6mm diameter shafts in slot, flat or round end styles
- Standard 15mm or 20mm shaft length
- Panel or PC board mounting styles
- Lug or right angle mount pin terminals

### Specifications

#### Electrical

**Standard Resistance Range** . . . . . B = 500Ω to 2MΩ  
 A,C = 1kΩ to 2MΩ

**Resistance Tolerance** . . . . . ±10% standard

**End Resistance** . . . . . 3Ω max.

**Resistance Taper** . . . . . B = linear; A = CW audio (logarithm);  
 C = CCW audio (logarithm)

**Peak Noise (C.R.V.)** . . . . . 2% max.

**Power Rating** . . . . . B = 0.25 watt; A,C = 0.125 watt  
 at +40°C, 0 watt at +85°C

**Maximum Input Voltage** . . . . . 350VDC or power rating,  
 whichever is smaller

**Insulation Resistance** . . . . . 100MΩ minimum at 1,000VDC

**Dielectric Strength** . . . . . 1,000VAC, 1 minute

**Adjustment Travel** . . . . . 270° ±10°

#### Mechanical

**Mechanical Travel** . . . . . 290° ±5°

**Shaft Torque** . . . . . 50 to 300 gf·cm (0.693 to 4.159 oz·in)

**Stop Strength** . . . . . 9 kgf·cm (124.76 oz·in) max.

**Mounting Nut Torque** . . . . . 15 kgf·cm (207.94 oz·in) max.

**Solderability** . . . . . 235°C, 5 seconds

**Marking** . . . . . Model type, taper, resistance code,  
 shaft type, terminal identification, date code

#### Environmental

**Temperature Range** . . . . . -10°C to +85°C

**Temperature Characteristics** . . . . . +80°C, 5 hours  
 without load  
 ΔT/R ≤ ±10%

**Load Life** . . . . . +40°C, 0.25 watt, 1,000 hours  
 ΔT/R ≤ ±10%

**Moisture and Load Life** . . . . . +40°C, 90-95% RH,  
 500 hours with rated load  
 ΔT/R ≤ ±10%

**Thermal Shock** . . . . . -10°C ~ +85°C,  
 5 cycles without load  
 ΔT/R ≤ ±10%

**Vibration** . . . . . 10-55Hz, 1.5mm amplitude,  
 3 directions, 2 hours each  
 ΔT/R ≤ ±4%

**Soldering Heat Resistance** . . . . . 350°C, 3 seconds  
 ΔT/R ≤ ±2%

**Rotational Life** . . . . . 15,000 cycles without load  
 ΔT/R ≤ ±7%

R = Total Resistance Value; ΔT/R = Total Resistance Change

**RV202YN**  
**Panel Mount, Single Unit, Single Shaft**  
**Right Angle Ear-Lug Terminals**

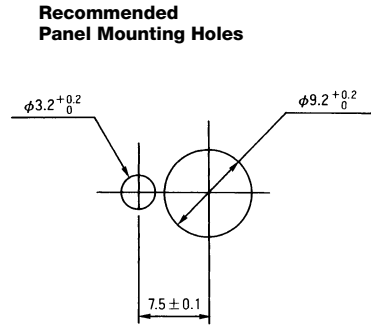
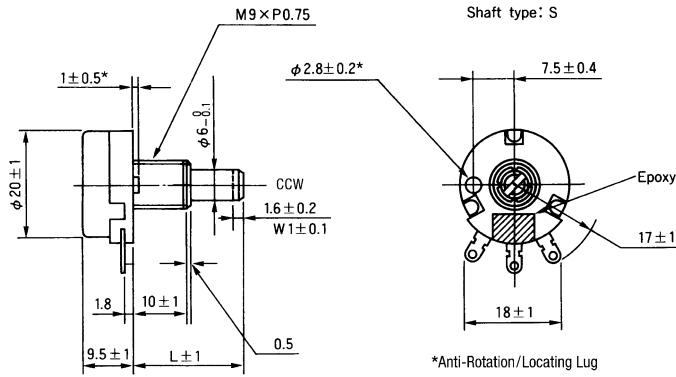

**RV202YP**  
**PCB Mount, Single Unit, Single Shaft**  
**Right Angle Mount Pin Terminals, 3-Pin Inline Pattern, 2-Pin Standoff Rear Support Bracket**

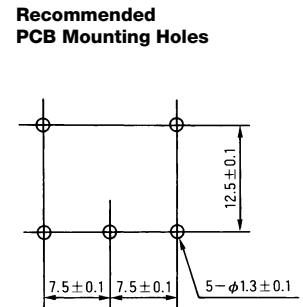
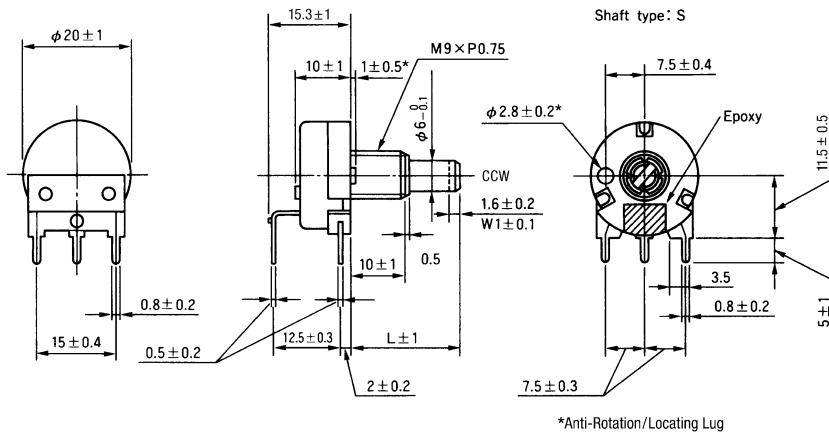

**RV 202 Y N 20 S B 103 K**

NOTE: FMS = From Mounting Surface

- ➔ **Resistance Tolerance: K** = ±10% (standard).
- ➔ **Resistance Code:** Expressed in ohms. A three digit code where the first two digits are significant figures, and the third digit indicates the number of zeros that follow these figures (i.e., 100 = 10Ω; 101 = 100Ω; 102 = 1,000Ω; 103 = 10,000Ω; 105 = 1,000,000Ω). See table for standard resistance values.
- ➔ **Resistance Taper: B** = Linear.  
**A** = CW Audio (logarithm).  
**C** = CCW Audio (logarithm).
- ➔ **Shaft End Style: S** = Slotted.  
**F** = Flatted.  
**R** = Round.
- ➔ **Standard Shaft Length: 15** = 15mm FMS.  
**20** = 20mm FMS.  
 Up to 30mm shaft length available (special order).
- ➔ **Style: N** = Panel Mount, Single Unit, Single Shaft, Right Angle Ear-Lug Terminals.  
**P** = PCB Mount, Single Unit, Single Shaft, Right Angle Mount Pin Terminals, 3-Pin Inline Pattern, 2-Pin Standoff Rear Support Bracket.
- ➔ **Operating Temperature Range: Y** = -10°C to +85°C.
- ➔ **Size and Style: 20** = 20mm Diameter; **2** = Style of 20mm Size.
- ➔ **TOCOS Series Name: RV** = Carbon Film Element.

Standard Resistance Values and Part Numbering Codes

Standard Nominal Total Resistance Values and Part Numbering Codes

Resistance (Ω)	Code	Resistance (Ω)	Code	Resistance (Ω)	Code	Resistance (Ω)	Code	Resistance (Ω)	Code
500	501	1,000	102	10,000	103	100,000	104	1,000,000	105
		2,000	202	20,000	203	200,000	204	2,000,000	205
		5,000	502	50,000	503	500,000	504		

Refer to Shaft End Styles Specifications and Hardware Specifications for details and availability.  
 For additional information, refer to Guidelines and Precautions for Using Panel Controls.