

IEC Appliance Inlet C14 with Line Switch 1- or 2-pole

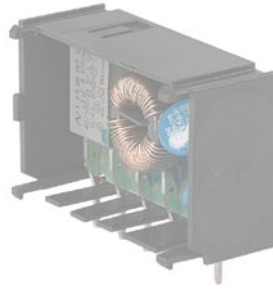

Inlet with line switch

KPF Filter Module
(not enclosed)**Description**

- Panel Mount:
Sandwich/rear-side
- 2 Functions:
Appliance Inlet Protection class I, Line Switch 1- and 2- pole
- For PCB mounting
- Alternative: version with line filter [KPF](#); [KPS](#)
- We recommend for new applications the new type [DC21](#)

Approvals

- VDE License Number: 40008635
- UL License Number: E96454
- CSA License Number: 38456

Characteristics

- Panel mount from rear or "sandwich" between top and bottom/side to side panels
PCB mount with snap-in or screw-on <BREAK/> feet (self tapping screws Ø 3 x 8 mm)
- All single elements are already wired
- Line switch non-illuminated
- Insulation cover on the rear-side
- Qualified for use in equipment according IEC/EN 60950

Other versions on request

- Solder terminals
- Quick-connect terminals
- Line switch, illuminated (only 2-pole version)
- Line switch with other rocker marking
- For protection class II

References

[General Product Information](#)

Weblinks

[Approvals](#), [RoHS](#), [CHINA-RoHS](#), [Mating Connectors](#), [e-Store](#), [Distributor-Stock-Check](#), [Accessories](#)

Technical Data

Ratings IEC	10A / 250VAC; 50Hz
Ratings UL/CSA	15A / 250VAC; 60Hz
Dielectric Strength	> 2.3kVAC between L-N > 2.8kVAC between L/N-PE (1 min/50Hz)
Allowable Operation Temp.	-25 °C to 70 °C
Degree of Protection	from front side IP 40 acc. to IEC 60529
Protection Class	Suitable for appliances with protection class 1 acc. to IEC 61140
Terminal	For PCB mounting Quick connect terminals 4.8 x 0.8 mm Solder terminal on request
Panel Thickness s	Snap-in: 1.5/2/2.5/3 mm
Material: Housing	Thermoplastic, black, UL 94V-0

Appliance Inlet	C14 acc. to IEC/EN 60320-1, UL 498, CSA C22.2 no. 42 (for cold conditions) pin-temperature 70 °C, 10A, Protection Class 1
Line Switch	Rocker switch 1 or 2 pole, non-illuminated, acc. to IEC 61058-1 Technical details

Dimensions

Screw on PCB mounting

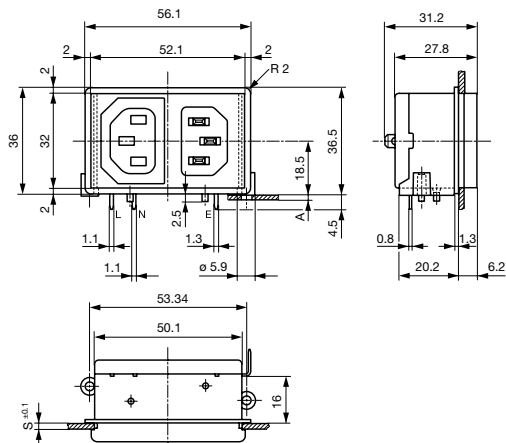

Snap-in mounting

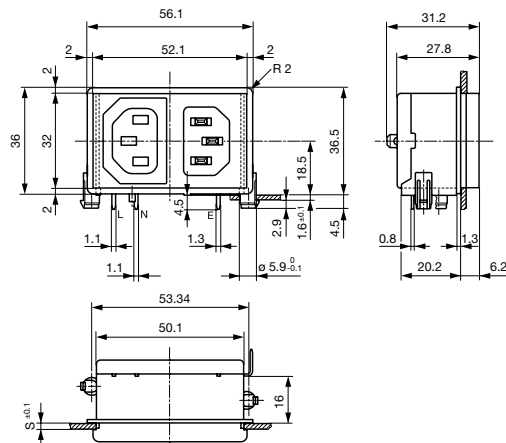

A = for PCB-thickness 1.2/1.6/2.0/2.4 mm
 Additional quick connect terminal 4.8 x 0.8 mm
 For 2-pole inlet/switch, 2-pole inlet fuseholder and inlet/outlet

Additional quick connect terminal 4.8 x 0.8 mm
 s = panel thickness
 for combinations:
 inlet/switch 1-pole
 Inlet/ fuseholder 1-pole

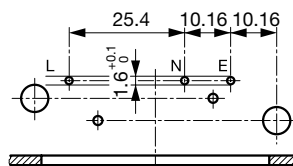
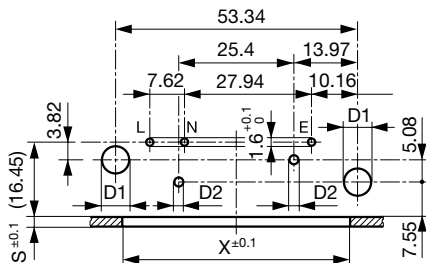

Mounting holes for backside mounting

Sandwich mounting holes

Sandwich mounting holes

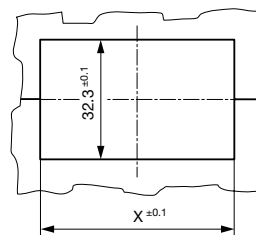
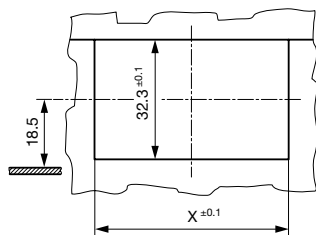
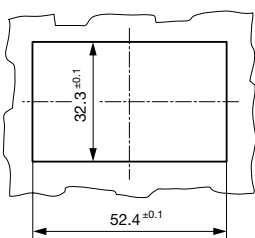

X = 48.4 at S = 1.5 and 2.5
 X = 50.4 at S = 2.0 and 3.0

X = 48.4 at S = 1.5 and 2.5
 X = 50.4 at S = 2.0 and 3.0

Dimensions

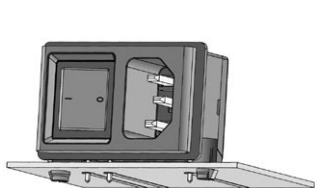

Stable snap feet requires minimal insertion force

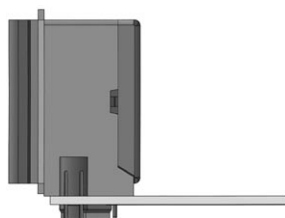

Module must lay flat on the PCB when soldering

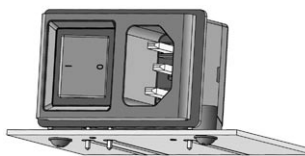

Screw-on mount uses self-tapping screws

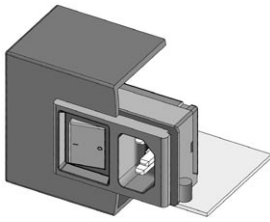

Insertion from behind

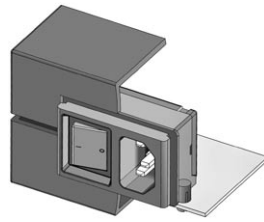

"Sandwich" mounting with split enclosure panels

Other dimensions as for 2-poles
 d1 = 6 ± 0.05 for (snap-in)
 d1 = 3.6 (screw-on)
 d2 = 2 ± 0.1 (screw-on)
 Dimensions without tolerance:
 ≤ 15 = ± 0.05; ≥ 15 = ± 0.1

Diagrams

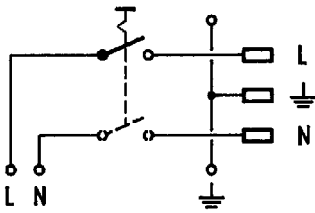

Inlet with line switch

Derating Curves

1-pole

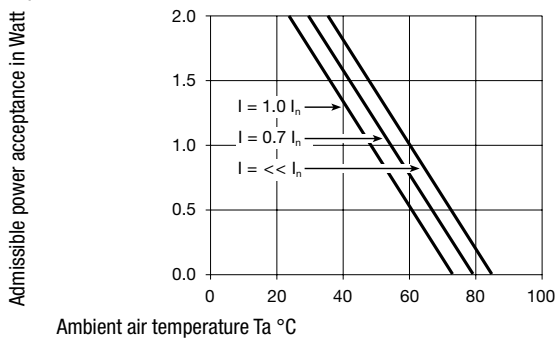

2-pole

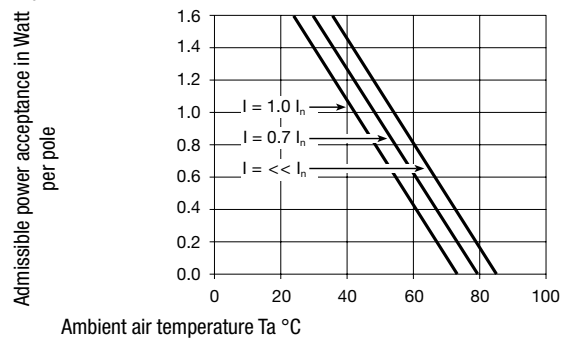

Variants

Panel mounting	Panel Thickness s [mm]	PCB [mm]	Line Switch	Fuseholder	Connector	Order Number
Screw	2	1.2/1.6/2.0/2.4	1-pole	-	-	KP01.1252.11
Screw	2	1.2/1.6/2.0/2.4	2-pole	-	-	KP01.1152.11
Screw	3	1.2/1.6/2.0/2.4	1-pole	-	-	KP01.1253.11
Screw	3	1.2/1.6/2.0/2.4	2-pole	-	-	KP01.1153.11
Snap-in	2	1.6	1-pole	-	-	KP01.1212.11
Snap-in	2	1.6	2-pole	-	-	KP01.1112.11
Snap-in	3	1.6	1-pole	-	-	KP01.1213.11
Snap-in	3	1.6	2-pole	-	-	KP01.1113.11

Type KP without cover: KP01.XXXX.XX90

Ground Terminal with solder pin: KP01.XXXX.X3XX

Packaging unit

50 Pcs

Mating Outlets/Connectors

Category / Description

Appliance Outlet Overview complete



IEC Appliance Outlet F, Screw-on Mounting, Front Side, Solder or Quick-connect Terminal	4787
IEC Appliance Outlet F, Snap-in Mounting, Front Side, Solder or Quick-connect Terminal	4788
IEC Appliance Outlet F or H, Screw-on Mounting, Front Side, Solder, PCB or Quick-connect Terminal	5091
IEC Appliance Outlet F or H, Screw-on Mounting, Front Side, Solder or Quick-connect Terminal	5092

[Appliance Outlet further types to KP \(Switch\)](#)

Connector Overview complete



IEC Connector C15, Rewireable, Straight	0101
IEC Connector C15A, Rewireable, Straight	0102
IEC Connector C15A, Rewireable, Straight	0102-G
IEC Connector C15A, Rewireable, Angled	0112
IEC Connector C13, Rewireable, Angled	4012

[Connector further types to KP \(Switch\)](#)

...

Power Cord Overview complete



Power Cord with IEC Connector C13, Angled	0311
Power Cord with IEC Connector C13, Angled	3011
Power Cord with IEC Connector C13, Angled	3012
Power Cord with IEC Connector C13, Angled	3013
Power Cord with IEC Connector C13	3020

[Power Cord further types to KP \(Switch\)](#)

...