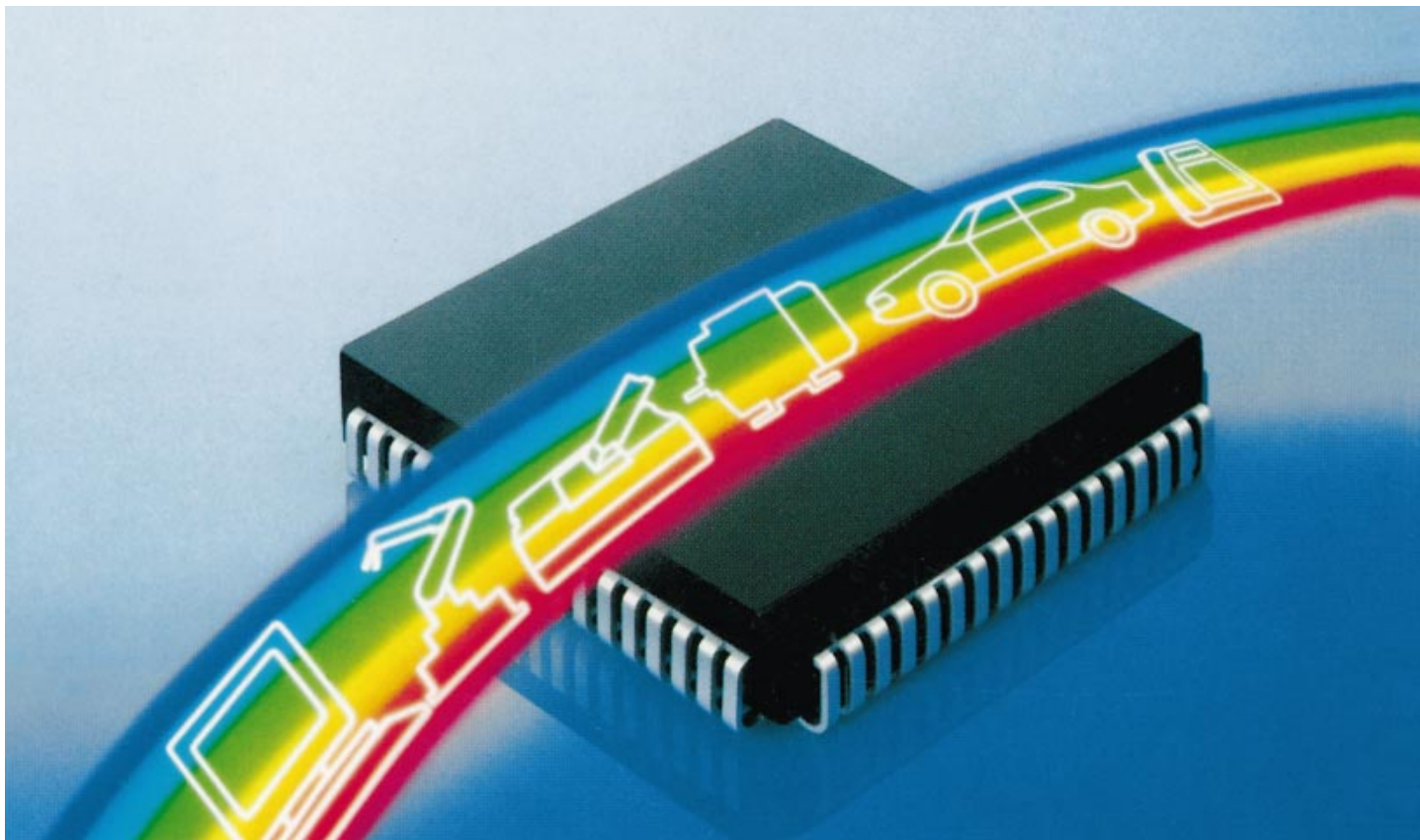


# SIEMENS



## Microcomputer Components

SAB 80C517A/83C517A-5  
8-Bit CMOS Single-Chip Microcontroller

## **Edition 05.94**

This edition was realized using the software system FrameMaker®.

**Published by Siemens AG,  
Bereich Halbleiter, Marketing-  
Kommunikation, Balanstraße 73,  
81541 München**

© Siemens AG 1994.  
All Rights Reserved.

### **Attention please!**

As far as patents or other rights of third parties are concerned, liability is only assumed for components, not for applications, processes and circuits implemented within components or assemblies.

The information describes the type of component and shall not be considered as assured characteristics.

Terms of delivery and rights to change design reserved.

For questions on technology, delivery and prices please contact the Semiconductor Group Offices in Germany or the Siemens Companies and Representatives worldwide (see address list).

Due to technical requirements components may contain dangerous substances. For information on the types in question please contact your nearest Siemens Office, Semiconductor Group.

Siemens AG is an approved CECC manufacturer.

### **Packing**

Please use the recycling operators known to you. We can also help you – get in touch with your nearest sales office. By agreement we will take packing material back, if it is sorted. You must bear the costs of transport.

For packing material that is returned to us unsorted or which we are not obliged to accept, we shall have to invoice you for any costs incurred.

### **Components used in life-support devices or systems must be expressly authorized for such purpose!**

Critical components<sup>1</sup> of the Semiconductor Group of Siemens AG, may only be used in life-support devices or systems<sup>2</sup> with the express written approval of the Semiconductor Group of Siemens AG.

- 1 A critical component is a component used in a life-support device or system whose failure can reasonably be expected to cause the failure of that life-support device or system, or to affect its safety or effectiveness of that device or system.
- 2 Life support devices or systems are intended (a) to be implanted in the human body, or (b) to support and/or maintain and sustain human life. If they fail, it is reasonable to assume that the health of the user may be endangered.

<b>SAB 80C517A/83C517A-5</b>	
<b>Revision History: 05.94</b>	
Previous Version: 11.92	
<b>Page</b>	<b>Subjects (major changes since last revision 11.92)</b>
3-8	S0RELL addresses corrected
4-1	$\overline{\text{HWPD}}$ pin number corrected
5-3	$T_s/T_c$ in table 5-1 corrected
5-10/5-11	CC4EN bit names and table 5-3 corrected
<b>Device Specifications SAB 80C517A/83C517A-5</b>	
<b>Revision History: 05.94</b>	
Previous Releases: 01.94/08.93/11.92/10.91/04.91	
<b>Page</b>	<b>Subjects (changes since last revision 04.91)</b>
5	Pin configuration P-MQFP-100-2 added
4	Pin differences updated
6-14	Pin numbers for P-MQFP-100-2 package added
several	Correction of P-MRFP-100 into P-MQFP-100-2
2	Ordering information for – 40 to + 110 °C versions
25,26,30	Correction of register names S0RELL, SCON, ADCON, ICRON and SBUF
33	Figure 4 corrected
39	Figure 8 corrected
57	$\overline{\text{PE}}$ /SWD function description completed
60	Correct ordering numbers
62	Test condition for $V_{OH}$ , $V_{OH1}$ corrected
65	$t_{PXIZ}$ name corrected
	$t_{AVIV}$ , $t_{AZPL}$ values corrected
several	Minimum clock frequency is now 3.5 MHz
66	$t_{QVWH}$ (data setup before $\overline{\text{WR}}$ ) corrected and added
68	$t_{LLAX2}$ corrected
<b>Page</b>	<b>Subjects (changes since last version 08.93)</b>
25	Corrected SFR name S0RELL
51	Below “Termination of HWPD Mode”: 4th paragraph with ident corrected
65	Description of $t_{LLIV}$ corrected
67	Program Memory Read Cycle: $f_{PXAV}$ added
74	Oscillator circuit drawings: MQFP-100-2 pin numbers added.
<b>Page</b>	<b>Subjects (changes since last revision 01.94)</b>
47	Minor changes on several pages Table 6 corrected

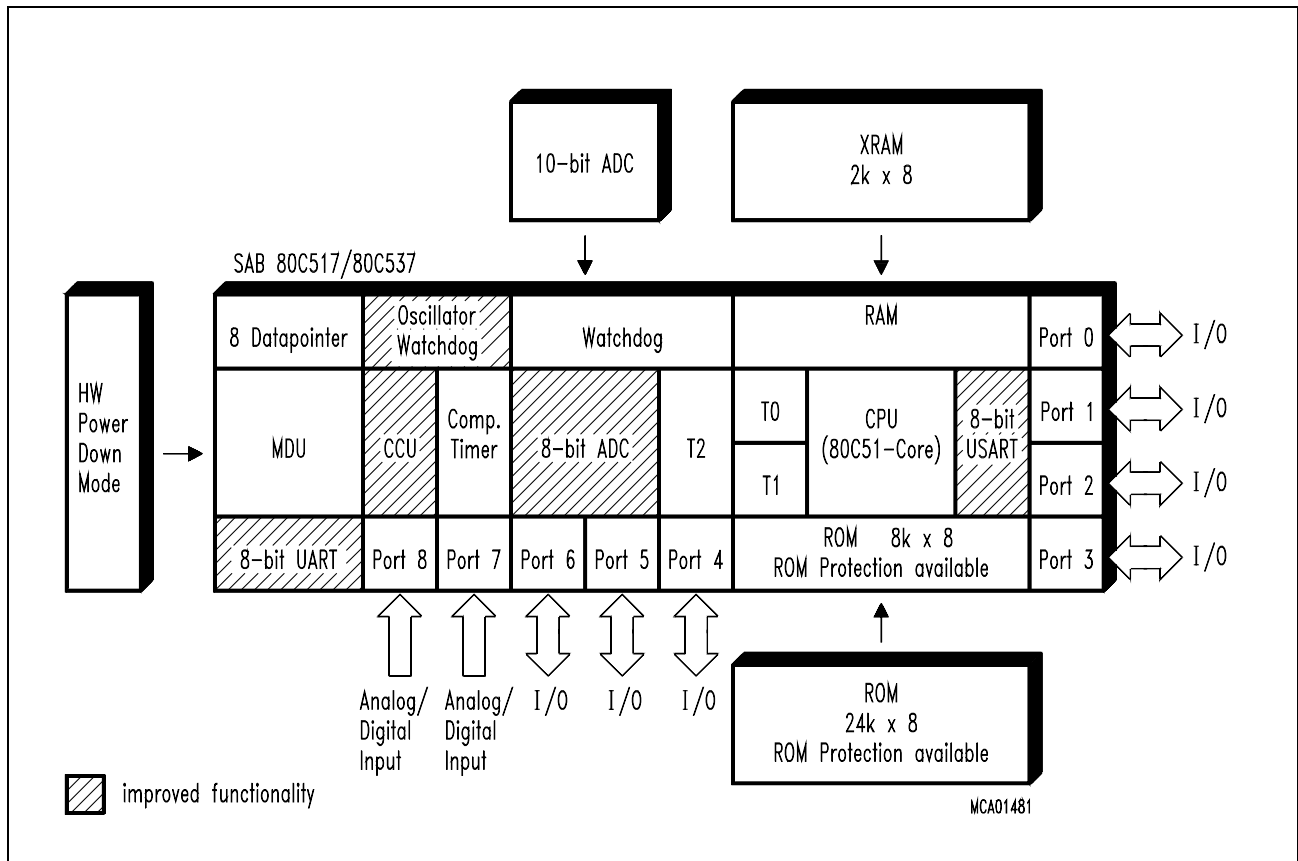
---

Contents	Page
<b>1 Introduction</b> .....	<b>1-1</b>
<b>2 Fundamental Structure</b> .....	<b>2-1</b>
<b>3 Memory Organization</b> .....	<b>3-1</b>
3.1 Program Memory, ROM Protection .....	3-2
3.2 Data Memory .....	3-3
3.3 Special Function Registers .....	3-4
3.4 Architecture for the XRAM .....	3-9
3.4.1 Accesses to XRAM .....	3-9
3.4.2 Control of XRAM in the SAB 80C517A .....	3-15
3.4.3 Behaviour of Port0 and Port2 .....	3-16
<b>4 System Reset</b> .....	<b>4-1</b>
4.1 Additional Hardware Power Down Mode in the SAB 80C517A .....	4-1
4.2 Hardware Power Down Reset Timing .....	4-4
4.3 Fast internal Reset after Power-On .....	4-8
<b>5 On-Chip Peripheral Components</b> .....	<b>5-1</b>
5.1 Digital I/O Port Circuitry .....	5-1
5.2 10-bit A/D-Converter .....	5-3
5.3 Additional Compare Mode for the Concurrent Compare Unit .....	5-8
5.4 New Baud Rate Generators for Serial Channel 0 and Serial Channel 1 ..	5-14
5.4.1 Serial Channel 0 Baud Rate Generator .....	5-14
5.4.2 Serial Channel 1 Baud Rate Generator .....	5-17
5.5 Modified Oscillator Watchdog Unit .....	5-19
<b>6 Interrupt System</b> .....	<b>6-1</b>
6.1 Additional Interrupt for Compare Registers CM0 to CM7 .....	6-1
6.2 Interrupt Structure .....	6-4
6.3 Priority Level Structure .....	6-5
<b>7 Device Specification</b> .....	<b>7-1</b>

## 1 Introduction

The SAB 80C517A is a superset of the high end microcontroller SAB 80C517.

While maintaining all architectural and operational characteristics of the SAB 80C517 the SAB 80C517A incorporates more on-chip RAM as well as some enhancements in the compare / capture unit. The oscillator watchdog got an improved functionality. Also the operating frequency is higher than that of the SAB 80C517.



## SAB 80C517A / 83C517A-5

In this manual, any reference made to the SAB 80C517A applies to both versions, the SAB 80C517A and the SAB 83C517A-5, unless otherwise noted. Furthermore only new features of the SAB 80C517A in addition to the features of the SAB 80C517A/83C517A-5 are described. For additional reference, the user's manual of the SAB 80C517/80C537 (Ord. No. B258-H6075-G1-X-7600) should be used.

Listed below is a summary of the main features of the SAB 80C517A:

- SAB 80C517A/83C517A-5, up to 18 MHz operation frequency
- 32 K×8 ROM (SAB 83C517A-5 only, ROM-Protection available)
- 256×8 on-chip RAM
- 2K×8 on-chip RAM (XRAM)
- Superset of SAB 80C51 architecture:
  - 1 μs instruction cycle time at 12 MHz
  - 666 ns instruction cycle time at 18 MHz
  - 256 directly addressable bits
  - Boolean processor
  - 64 Kbyte external data and program memory addressing
- Four 16-bit timer/counters
- Powerful 16-bit compare/capture unit (CCU) with up to 21 high-speed or PWM output channels and 5 capture inputs
- Versatile "fail-safe" provisions
- Fast 32-bit division, 16-bit multiplication, 32-bit normalize and shift by peripheral MUL/DIV unit (MDU)
- Eight data pointers for external memory addressing
- Seventeen interrupt vectors, four priority levels selectable
- genuine 10-bit A/D converter with 12 multiplexed inputs
- Two full duplex serial interfaces with programmable Baudrate-Generators
- Fully upward compatible with SAB 80C515, SAB 80C517, SAB 80C515A
- Extended power saving modes
- Fast Power-On Reset
- Nine ports: 56 I/O lines, 12 input lines
- Three temperature ranges available:
  - 0 to 70 °C (T1)
  - 40 to + 85 °C (T3)
  - 40 to + 110 °C (T4)
- Plastic packages: P-LCC-84  
P-MQFP-100-2

The pin functions of the SAB 80C517A are identical with those of the SAB 80C517/80C537 with one exception:

Package	SAB 80C517A	SAB 80C517 / 80C537
PLCC-84/60		
PMRFP-100/72	$\overline{\text{HWPD}}$	$V_{\text{SS}}$

### 2 Fundamental Structure

The SAB 80C517A/83C517A-5 is a high-end member of the Siemens SAB 8051 family of microcontrollers. It is designed in Siemens ACMOS technology and based on the SAB 8051 architecture. ACMOS is a technology which combines high-speed and density characteristics with low-power consumption or dissipation.

While maintaining all the SAB 80C517 features and operating characteristics the SAB 80C517A is expanded in its "fail-safe" characteristics and timer capabilities.

Furthermore, the SAB 80C517A additionally contains 2 kByte of on-chip RAM (called XRAM), a 10bit A/D converter with 12 multiplexed inputs, enhanced Baud Rate Generators and the capabilities of the Compare Capture Unit are improved.

The SAB 80C517A is identical with the SAB 83C517A-5 except that it lacks the on-chip program memory. The SAB 80C517A / 83C517A-5 is supplied in a 84-pin plastic leaded chip carrier package (P-LCC-84) and in a 100-pin plastic metric rectangular flat package (P-MRFP-100).

The essential enhancements to the SAB 80C517 are:

- Additional 2KByte RAM on chip.
- 32 kByte on-chip program memory (SAB 83C517A-5 only)
- 12-channel 10-bit A/D Converter
- Additional Compare Mode for Concurrent Compare function at Port 5; up to eight pins on P5 can be either set or reset on a compare match in two additional compare registers.
- Dedicated interrupt vector for the 16-bit compare registers CM0-CM7: Interrupt requested on a compare match in one of the eight compare channels (eight request flags are available)
- New baud rate generator for Serial Channel 0
- Expanded baud rate range for Serial Channel 1
- Hardware controlled Power Down Mode
- Improved functionality of the Oscillator Watchdog
- High speed operation of the device (up to 18 MHz crystal frequency)

**Figure 2-1** shows a block diagram of the SAB 80C517A

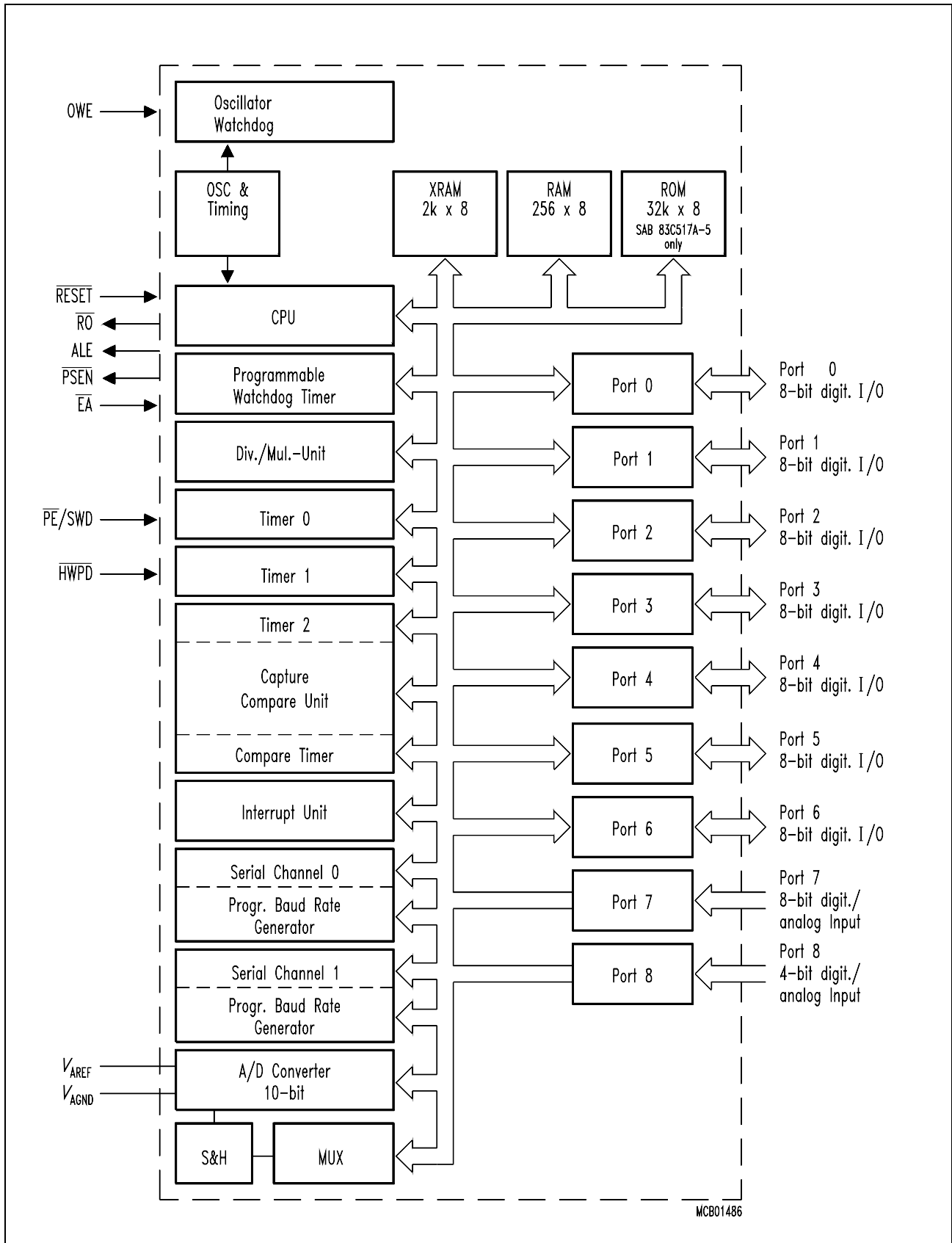
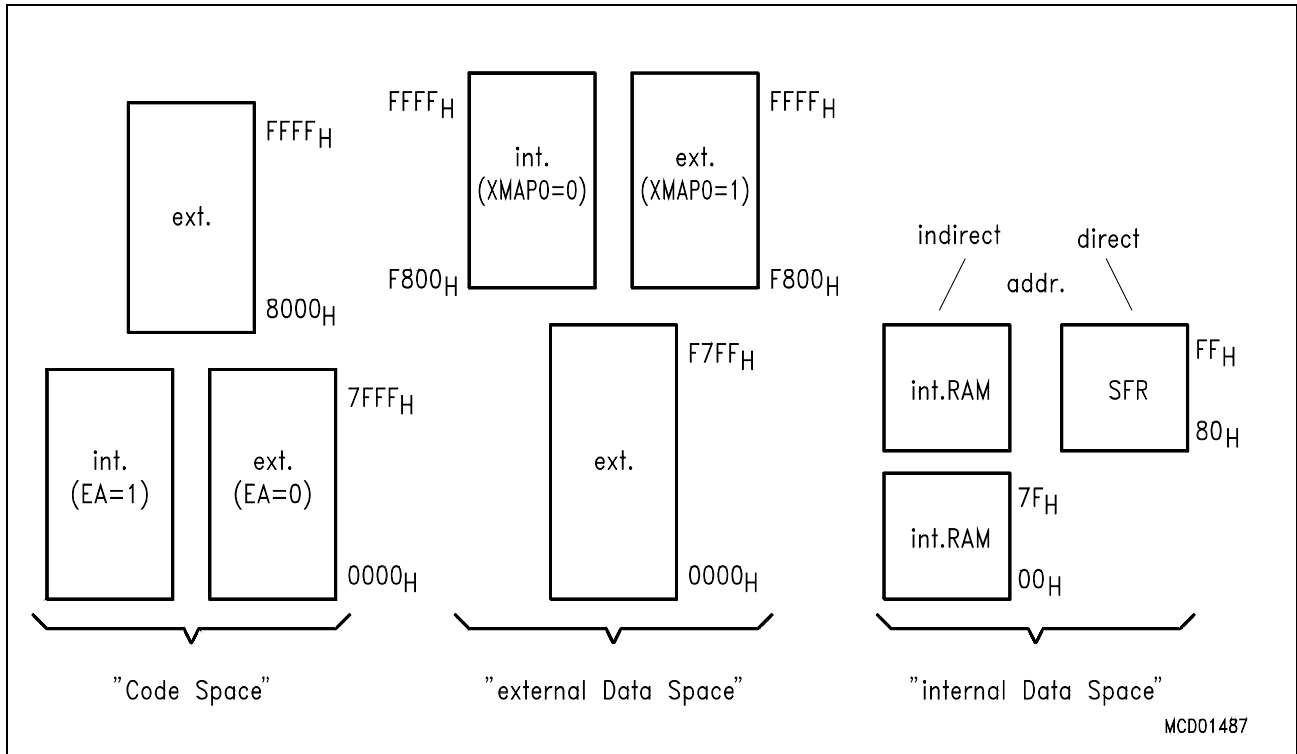


Figure 2-1, Block Diagram of the SAB 80C517A



3 Memory Organization

According to the SAB 8051 architecture, the SAB 80C517A has separate address spaces for program and data memory. **Figure 3-1** illustrates the mapping of address spaces.



**Figure 3-1**  
Memory Map

### 3.1 Program Memory, ROM Protection

The SAB 83C517A-5 has 32 Kbyte of on-chip ROM, while the SAB 80C517A has no internal ROM. The program memory can externally be expanded up to 64 Kbyte. Pin  $\overline{EA}$  controls whether program fetches below address 8000H are done from internal or external memory.

As a new feature the SAB 83C517A-5 offers the possibility of protecting the internal ROM against unauthorized access. This protection is implemented in the ROM-Mask. Therefore, the decision ROM-Protection 'yes' or 'no' has to be made when delivering the ROM-Code. Once enabled, there is no way of disabling the ROM-Protection.

Effect : The access to internal ROM done by an externally fetched MOVC instruction is disabled. Nevertheless, an access from internal ROM to external ROM is possible.

To verify the read protected ROM-Code a special ROM-Verify-Mode is implemented. This mode also can be used to verify unprotected internal ROM.

ROM-Protection	ROM-Verification Mode (see 'AC Characteristics')	Restrictions
no	ROM-Verification Mode 1 (standard 8051 Verification Mode) ROM-Verification Mode 2	–
yes	ROM-Verification Mode 2	– standard 8051 Verification Mode is disabled – externally applied MOVC accessing to internal ROM is disabled

### 3.2 Data Memory

The data memory space consists of an internal and an external memory space. The SAB 80C517A contains another 2 kByte of On-Chip RAM above the 256 Bytes internal RAM of the base type SAB 80C517. This RAM is called XRAM in this document.

- External Data Memory

Up to 64 Kbyte external data memory can be addressed by instructions that use 8-bit or 16-bit indirect addressing. For 8-bit addressing MOVX instructions in combination with registers R0 and R1 can be used. A 16-bit external memory addressing is supported by eight 16-bit datapointers. Registers XPAGE and SYSCON are controlling whether data fetches at addresses F800<sub>H</sub> to FFFF<sub>H</sub> are done from internal XRAM or from external data memory.

- Internal Data Memory

The internal data memory is divided into four physically distinct blocks:

- the lower 128 bytes of RAM including four banks containing eight registers each
- the upper 128 byte of RAM
- the 128 byte special function register area
- a 2Kx8 area which is accessed like external RAM (MOVX-instructions), called XRAM implemented on chip at the address range from F800<sub>H</sub> to FFFF<sub>H</sub>. Special Function Register SYSCON controls whether data is read or written (to) XRAM or external RAM

### 3.3 Special Function Registers

All registers, except the program counter and the four general purpose register banks, reside in the special function register area. The 81 special function registers include arithmetic registers, pointers, and registers that provide an interface between the CPU and the on-chip peripherals. There are also 128 directly addressable bits within the SFR area. All special function registers are listed in **table 3-1** and **table 3-2**.

In **table 3-1** they are organized in numeric order of their addresses. In **table 3-2** they are organized in groups which refer to the functional blocks of the SAB 80C517A.

**Table 3-1, Special Function Register**

Address	Register	Contents after Reset	Address	Register	Contents after Reset
<b>80H</b>	<b>P0</b> <sup>1)</sup>	<b>FFH</b>	<b>A0H</b>	<b>P2</b> <sup>1)</sup>	<b>FFH</b>
81H	SP	07H	A1H	COMSETL	00H
82H	DPL	00H	A2H	COMSETH	00H
83H	DPH	00H	A3H	COMCLRL	00H
84H	(WDTL)	–	A4H	COMCLRH	00H
85H	(WDTH)	–	A5H	SETMSK	00H
86H	WDTREL	00H	A6H	CJRMSK	00H
87H	PCON	00H	A7H	–	–
<b>88H</b>	<b>TCON</b> <sup>1)</sup>	<b>00H</b>	<b>A8H</b>	<b>IEN0</b> <sup>1)</sup>	<b>00H</b>
89H	TMOD	00H	A9H	IP0	00H
8AH	TL0	00H	AAH	SORELL	D9H
8BH	TL1	00H	ABH	–	–
8CH	TH0	00H	ACH	–	–
8DH	TH1	00H	ADH	–	–
8EH	–	–	AEH	–	–
8FH	–	–	A FH	–	–
<b>90H</b>	<b>P1</b> <sup>1)</sup>	<b>FFH</b>	<b>B0H</b>	<b>P3</b> <sup>1)</sup>	<b>FFH</b>
91H	XPAGE	00H	B1H	SYSCON	XXXX XX01B
92H	DPSEL	XXXXX000B	B2H	–	–
93H	–	–	B3H	–	–
94H	–	–	B4H	–	–
95H	–	–	B5H	–	–
96H	–	–	B6H	–	–
97H	–	–	B7H	–	–
<b>98H</b>	<b>S0CON</b> <sup>1)</sup>	<b>00H</b>	<b>B8H</b>	<b>IEN1</b> <sup>1)</sup>	<b>00H</b>
99H	S0BUF	XXH	B9H	IP1	XX00 0000B
9AH	IEN2	XX00 00X0B	BAH	S0RELH	XXXX XX11B
9BH	S1CON	0X00 0000B	BBH	S1RELH	XXXX XX11B
9CH	S1BUF	XXH	BCH	–	–
9DH	S1RELL	00H	BDH	–	–
9EH	–	–	BEH	–	–
9FH	–	–	B FH	–	–

1) : Bit-addressable Special Function Register

**Table 3-1, Special Function Register (cont'd)**

Address	Register	Contents after Reset	Address	Register	Contents after Reset
<b>C0H</b>	<b>IRCON0</b> <sup>1)</sup>	<b>00H</b>	<b>E0H</b>	<b>ACC</b> <sup>1)</sup>	<b>00H</b>
C1H	CCEN	00H	E1H	CTCON	0X00 0000 <sub>B</sub>
C2H	CCL1	00H	E2H	CML3	00H
C3H	CCH1	00H	E3H	CMH3	00H
C4H	CCL2	00H	E4H	CML4	00H
C5H	CCH2	00H	E5H	CMH4	00H
C6H	CCL3	00H	E6H	CML5	00H
C7H	CCH3	00H	E7H	CMH5	00H
<b>C8H</b>	<b>T2CON</b> <sup>1)</sup>	<b>00H</b>	<b>E8H</b>	<b>P4</b> <sup>1)</sup>	<b>FFH</b>
C9H	CC4EN	00H	E9H	MD0	XXH
CAH	CRCL	00H	EAH	MD1	XXH
CBH	CRCH	00H	EBH	MD2	XXH
CCH	TL2	00H	ECH	MD3	XXH
CDH	TH2	00H	EDH	MD4	XXH
CEH	CCL4	00H	EEH	MD5	XXH
CFH	CCH4	00H	EFH	ARCON	0XXX XXXX <sub>B</sub>
<b>D0H</b>	<b>PSW</b> <sup>1)</sup>	<b>00H</b>	<b>F0</b>	<b>B</b> <sup>1)</sup>	<b>00H</b>
D1H	IRCON1	00H	F1H	–	–
D2H	CML0	00H	F2H	CML6	00H
D3H	CMH0	00H	F3H	CMH6	00H
D4H	CML1	00H	F4H	CML7	00H
D5H	CMH1	00H	F5H	CMH7	00H
D6H	CML2	00H	F6H	CMEN	00H
D7H	CMH2	00H	F7H	CMSEL	00H
<b>D8H</b>	<b>ADCON0</b> <sup>1)</sup>	<b>00H</b>	<b>F8H</b>	<b>P5</b> <sup>1)</sup>	<b>FFH</b>
D9H	ADDATH	00H	F9H	–	–
DAH	ADDATL	00H	FAH	P6	FFH
DBH	P7	XXH	FBH	–	–
DCH	ADCON1	XXXX 0000 <sub>B</sub>	FBH	–	–
DDH	P8	XXH	FDH	–	–
DEH	CTRELL	00H	FEH	–	–
DFH	CTRELH	00H	FFH	–	–

1) : Bit-addressable Special Function Register

**Table 3-1, Special Function Register (cont'd)**

Block	Symbol	Name	Address	Contents after Reset
XRAM	XPAGE	Page Address. Reg. for extended onchip RAM	91H	00H
	SYSCON	XRAM Control Reg.	B1H	XXXX XX01B <sup>3)</sup>
CPU	ACC	Accumulator	<b>E0H</b> <sup>1)</sup>	00H
	B	B-Register	<b>F0H</b> <sup>1)</sup>	00H
	DPH	Data Pointer, High Byte	83H	00H
	DPL	Data Pointer, Low Byte	82H	00H
	DPSEL	Data Pointer Select Register	92H	XXXXXX000B <sup>3)</sup>
	PSW	Program Status Word Register	<b>D0H</b> <sup>1)</sup>	00H
	SP	Stack Pointer	81H	07H
A/D-Converter	ADCON0	A/D Converter Control Register 0	<b>D8H</b> <sup>1)</sup>	00H
	ADCON1	A/D Converter Control Register 1	DH	00H
	ADDATH	A/D Converter Data Register High Byte	D9H	00H
	ADDATL	A/D Converter Data Register Low Byte	DAH	00H
Interrupt System	IEN0	Interrupt Enable Register 0	<b>A8H</b> <sup>1)</sup>	00H
	CTCON <sup>2)</sup>	Com. Timer Control Register	E1H	0X00 0000B <sup>3)</sup>
	IEN1	Interrupt Enable Register 1	<b>B8H</b> <sup>1)</sup>	00H
	IEN2	Interrupt Enable Register 2	9AH	XX00 00X0B <sup>3)</sup>
	IP0	Interrupt Priority Register 0	A9H	00H
	IP1	Interrupt Priority Register 1	B9H	XX00 0000B
	IRCON0	Interrupt Request Control Register	<b>C0H</b> <sup>1)</sup>	00H
	IRCON1	Interrupt Request Control Register	D1H	00H
	TCON <sup>2)</sup>	Timer Control Register	<b>88H</b> <sup>1)</sup>	00H
	T2CON <sup>2)</sup>	Timer 2 Control Register	<b>0C8H</b> <sup>1)</sup>	00H
MUL/DIV Unit	ARCON	Arithmetic Control Register	EFH	0XXX XXXXB
	MD0	Multiplication/Division Register 0	E9H	XXH
	MD1	Multiplication/Division Register 1	EAH	XXH
	MD2	Multiplication/Division Register 2	EBH	XXH
	MD3	Multiplication/Division Register 3	ECH	XXH
	MD4	Multiplication/Division Register 4	EDH	XXH
	MD5	Multiplication/Division Register 5	EEH	XXH
Compare/Capture-Unit (CCU), Timer2	CCEN	Comp./Capture Enable Reg.	C1H	00H
	CC4EN	Comp./Capture 4 Enable Reg.	C9H	00H
	CCH1	Comp./Capture Reg. 1, High Byte	C3H	00H
	CCH2	Comp./Capture Reg. 2, High Byte	C5H	00H
	CCH3	Comp./Capture Reg. 3, High Byte	C7H	00H
	CCH4	Comp./Capture Reg. 4, High Byte	CFH	00H
	CCL1	Comp./Capture Reg. 1, Low Byte	C2H	00H

1) Bit-addressable special function registers

2) This special function register is listed repeatedly since some bits of it also belong to other functional blocks.

3) X means that the value is indeterminate

**Table 3-1, Special Function Register**

Block	Symbol	Name	Address	Contents after Reset
Compare/ Capture- Unit (CCU) (cont'd)	CCL2	Comp./Capture Reg. 2, Low Byte	C4 <sub>H</sub>	00 <sub>H</sub>
	CCL3	Comp./Capture Reg. 3, Low Byte	C6 <sub>H</sub>	00 <sub>H</sub>
	CCL4	Comp./Capture Reg. 4, Low Byte	CE <sub>H</sub>	00 <sub>H</sub>
	CMEM	Compare Enable Register	F6 <sub>H</sub>	00 <sub>H</sub>
	CMH0	Compare Reg. 0, High Byte	D3 <sub>H</sub>	00 <sub>H</sub>
	CMH1	Compare Reg. 1, High Byte	D5 <sub>H</sub>	00 <sub>H</sub>
	CMH2	Compare Reg. 2, High Byte	D7 <sub>H</sub>	00 <sub>H</sub>
	CMH3	Compare Reg. 3, High Byte	E3 <sub>H</sub>	00 <sub>H</sub>
	CMH4	Compare Reg. 4, High Byte	E5 <sub>H</sub>	00 <sub>H</sub>
	CMH5	Compare Reg. 5, High Byte	E7 <sub>H</sub>	00 <sub>H</sub>
	CMH6	Compare Reg. 6, High Byte	F3 <sub>H</sub>	00 <sub>H</sub>
	CMH7	Compare Reg. 7, High Byte	F5 <sub>H</sub>	00 <sub>H</sub>
	CML0	Compare Register 0, Low Byte	D2 <sub>H</sub>	00 <sub>H</sub>
	CML1	Compare Register 1, Low Byte	D4 <sub>H</sub>	00 <sub>H</sub>
	CML2	Compare Register 2, Low Byte	D6 <sub>H</sub>	00 <sub>H</sub>
	CML3	Compare Register 3, Low Byte	E2 <sub>H</sub>	00 <sub>H</sub>
	CML4	Compare Register 4, Low Byte	E4 <sub>H</sub>	00 <sub>H</sub>
	CML5	Compare Register 5, Low Byte	E6 <sub>H</sub>	00 <sub>H</sub>
	CML6	Compare Register 6, Low Byte	F2 <sub>H</sub>	00 <sub>H</sub>
	CML7	Compare Register 7, Low Byte	F4 <sub>H</sub>	00 <sub>H</sub>
	CMSEL	Compare Input Select	F7 <sub>H</sub>	00 <sub>H</sub>
	CRCH	Com./Rel./Capt. Reg. High Byte	CB <sub>H</sub>	00 <sub>H</sub>
	CRCL	Com./Rel./Capt. Reg. Low Byte	CA <sub>H</sub>	00 <sub>H</sub>
	COMSETL	Compare register, Low Byte	A1 <sub>H</sub>	00 <sub>H</sub>
	COMSETH	Compare register, High Byte	A2 <sub>H</sub>	00 <sub>H</sub>
	COMCLRL	Compare register, Low Byte	A3 <sub>H</sub>	00 <sub>H</sub>
	COMCLRH	Compare register, High Byte	A4 <sub>H</sub>	00 <sub>H</sub>
	SETMSK	mask register, concerning COMSET	A5 <sub>H</sub>	00 <sub>H</sub>
	CLRMSK	mask register, concerning COMCLR	A6 <sub>H</sub>	00 <sub>H</sub>
	CTCON	Com. Timer Control Reg.	E1 <sub>H</sub>	0X00 0000 <sub>B</sub> <sup>3)</sup>
	CTRELH	Com. Timer Rel. Reg., High Byte	DF <sub>H</sub>	00 <sub>H</sub>
	CTRELL	Com. Timer Rel. Reg., Low Byte	DE <sub>H</sub>	00 <sub>H</sub>
	TH2	Timer 2, High Byte	CD <sub>H</sub>	00 <sub>H</sub>
	TL2	Timer 2, Low Byte	CC <sub>H</sub>	00 <sub>H</sub>
	T2CON	Timer 2 Control Register	<b>C8<sub>H</sub></b> <sup>1)</sup>	00 <sub>H</sub>

1) Bit-addressable special function registers

2) This special function register is listed repeatedly since some bits of it also belong to other functional blocks.

3) X means that the value is indeterminate

**Table 3-1, Special Function Register**

Block	Symbol	Name	Address	Contents after Reset
Ports	P0	Port 0	<b>80H</b> <sup>1)</sup>	FFH
	P1	Port 1	<b>90H</b> <sup>1)</sup>	FFH
	P2	Port 2	<b>A0H</b> <sup>1)</sup>	FFH
	P3	Port 3	<b>B0H</b> <sup>1)</sup>	FFH
	P4	Port 4	<b>E8H</b> <sup>1)</sup>	FFH
	P5	Port 5	<b>F8H</b> <sup>1)</sup>	FFH
	P6	Port 6	FAH	FFH
	P7	Port 7, Analog/Digital Input	DBH	–
	P8	Port 8, Analog/Digital Input, 4-bit	DDH	–
Pow. Save Modes	PCON	Power Control Register	87H	00H
Serial Channels	ADCON0 <sup>2)</sup>	A/D Converter Control Reg.	<b>D8H</b> <sup>1)</sup>	00H
	PCON <sup>2)</sup>	Power Control Register	87H	00H
	S0BUF	Serial Channel 0 Buffer Reg.	99H	XXH
	S0CON	Serial Channel 0 Control Reg.	<b>98H</b> <sup>1)</sup>	00H
	S0RELL	Serial Channel 0 Reload Reg., low byte	0AAH	D9H
	S0RELH	Serial Channel 0 Reload Reg., high byte	BAH	XXXX XX11B <sup>3)</sup>
	S1BUF	Serial Channel 1 Buffer Reg.	9CH	XXH <sup>3)</sup>
	S1CON	Serial Channel 1 Control Reg.	9BH	0X00 0000B <sup>3)</sup>
	S1RELL	Serial Channel 1 Reload Reg., low byte	9DH	00H
S1RELH	Serial Channel 1 Reload Reg., high byte	BBH	XXXX XX11B <sup>3)</sup>	
Timer 0/ Timer 1	TCON	Timer Control Register	<b>88H</b> <sup>1)</sup>	00H
	TH0	Timer 0, High Byte	8CH	00H
	TH1	Timer 1, High Byte	8DH	00H
	TL0	Timer 0, Low Byte	8AH	00H
	TL1	Timer 1, Low Byte	8BH	00H
	TMOD	Timer Mode Register	89H	00H
Watchdog	IEN0 <sup>2)</sup>	Interrupt Enable Register 0	<b>A8H</b> <sup>1)</sup>	00H
	IEN1 <sup>2)</sup>	Interrupt Enable Register 1	<b>B8H</b> <sup>1)</sup>	00H
	IPO <sup>2)</sup>	Interrupt Priority Register 0	A9H	00H
	IP1 <sup>2)</sup>	Interrupt Priority Register 1	B9H	XX00 0000B <sup>3)</sup>
	WDTREL	Watchdog Timer Reload Reg.	86H	00H

1) Bit-addressable special function registers

2) This special function register is listed repeatedly since some bits of it also belong to other functional blocks.

3) X means that the value is indeterminate



### 3.4 Architecture for the XRAM

The contents of the XRAM is not affected by a reset or HW Power Down. After power-up the contents is undefined, while it remains unchanged during and after a reset or HW Power Down if the power supply is not turned off.

The additional On-Chip RAM is logically located in the "external data memory" range at the upper end of the 64 KByte address range (F800<sub>H</sub>-FFFF<sub>H</sub>). It is possible to enable and disable (only by reset) the XRAM. If it is disabled the device shows the same behaviour as the parts without XRAM, i.e. all MOVX accesses use the external bus to physically external data memory.

#### 3.4.1 Accesses to XRAM

Because the XRAM is used in the same way as external data memory the same instruction types must be used for accessing the XRAM.

##### Note:

If a reset occurs during a write operation to XRAM, the effect on XRAM depends on the cycle which the reset is detected at (MOVX is a 2-cycle instruction):

Reset detection at cycle 1: The new value will not be written to XRAM. The old value is not affected.

Reset detection at cycle 2: The old value in XRAM is overwritten by the new value.

#### Accesses to XRAM using the DPTR

There are a Read and a Write instruction from and to XRAM which use one of the 16-bit DPTR for indirect addressing. The instructions are:

MOVX    A, @DPTR   (Read)

MOVX    @DPTR, A   (Write)

Normally the use of these instructions would use a physically external memory. However, in the SAB 80C517A the XRAM is accessed if it is enabled and if the DPTR points to the XRAM address space (DPTR ≥ F800<sub>H</sub>).

### Accesses to XRAM using the Registers R0/R1

The 8051 architecture provides also instructions for access to external data memory range which use only an 8-bit address (indirect addressing with registers R0 or R1). The instructions are:

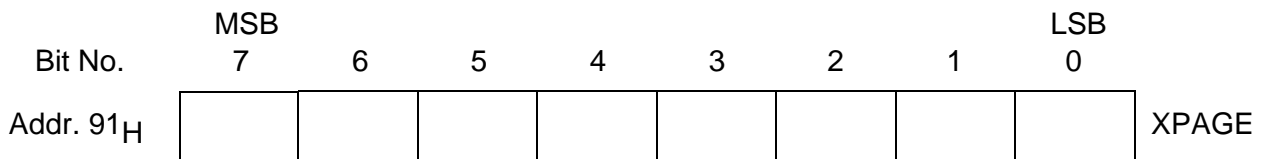
```

MOVX    A, @ Ri    (Read)
MOVX    @Ri, A    (Write)
    
```

In application systems, either a real 8-bit bus (with 8-bit address) is used or Port 2 serves as page register which selects pages of 256-Byte. However, the distinction, whether Port 2 is used as general purpose I/O or as "page address" is made by the external system design. From the device's point of view it cannot be decided whether the Port 2 data is used externally as address or as I/O data!

Hence, a special page register is implemented into the SAB 80C517A to provide the possibility of accessing the XRAM also with the MOVX @Ri instructions, i.e. XPAGE serves the same function for the XRAM as Port 2 for external data memory.

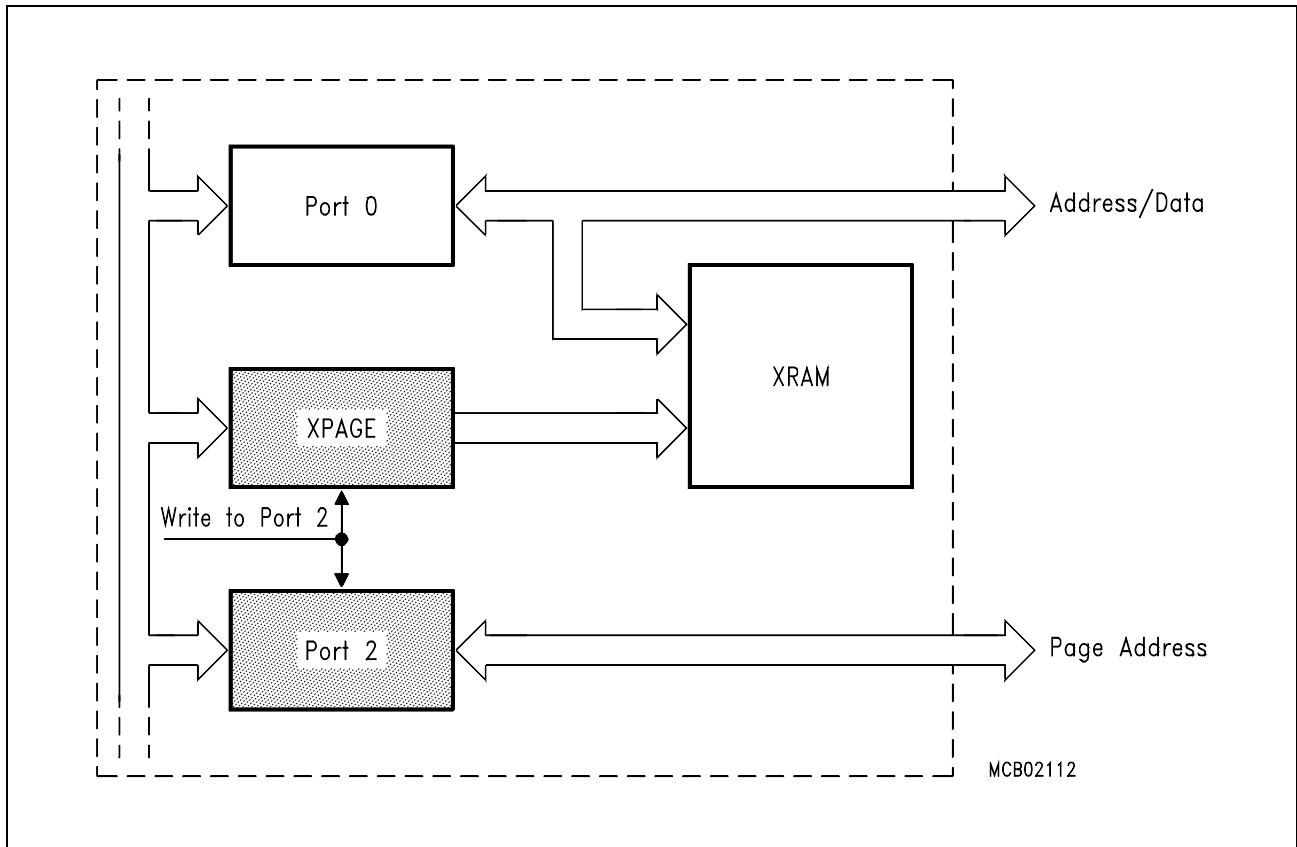
### Special Function Register XPAGE



The reset value of XPAGE is 00<sub>H</sub>.

XPAGE can be set and read by software.

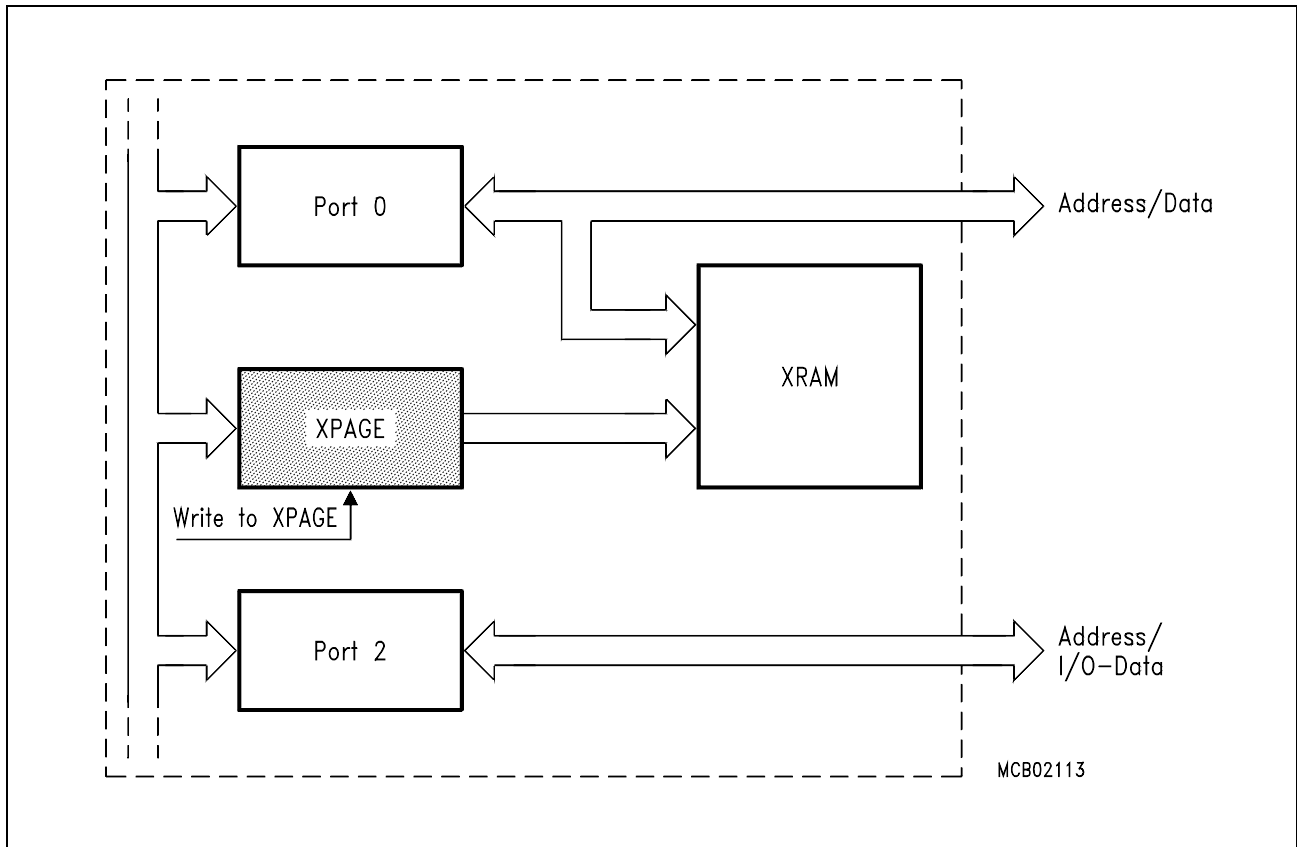
**Figures 3-2 to 3-4** show the dependencies of XPAGE- and Port 2 - addressing in order to explain the differences in accessing XRAM, ext. RAM or what is to do when Port 2 is used as an I/O-port.



**Figure 3-2**  
**Write Page Address to Port 2**

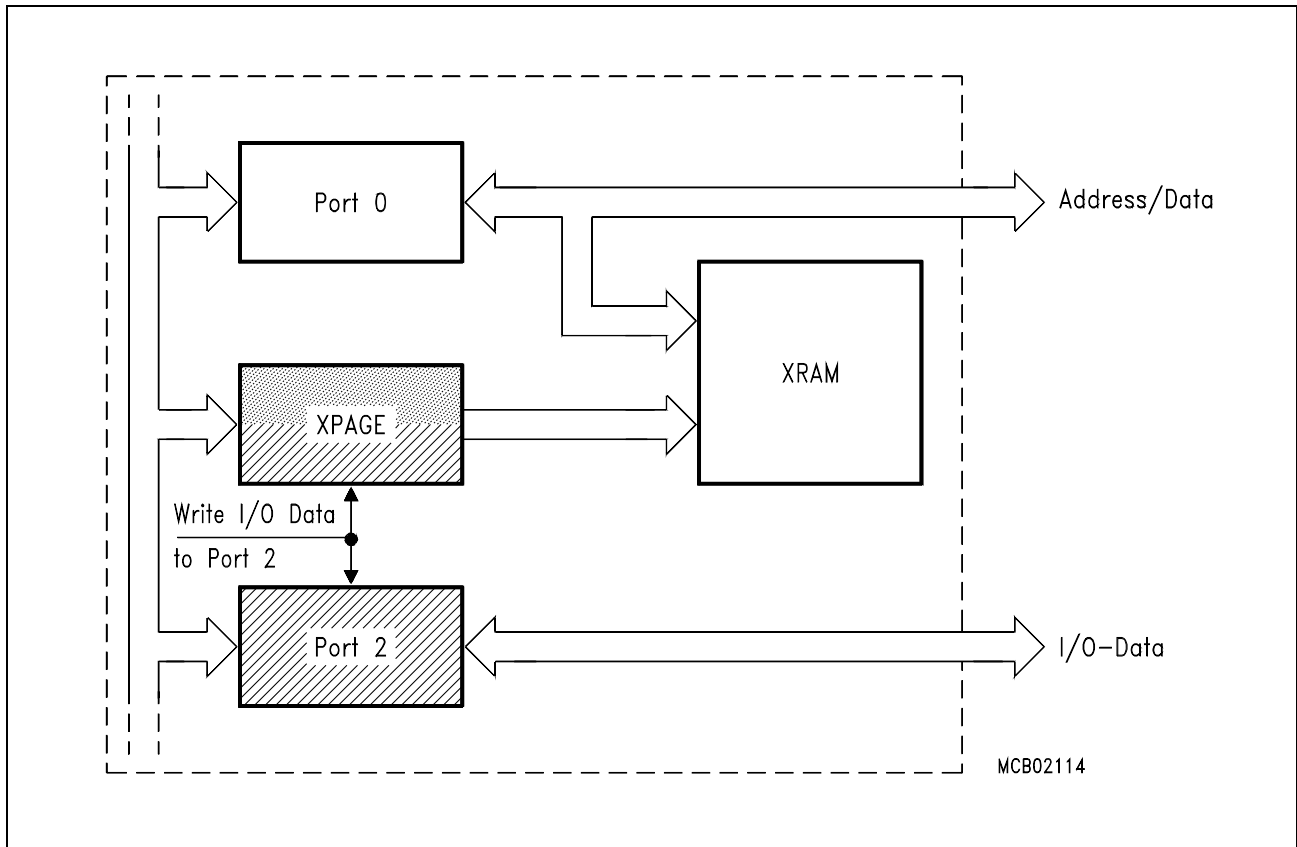
MOV P2, pageaddress will write the page address to Port 2 **and** XPAGE-Register.

When external RAM is to be accessed in the XRAM address range (F800<sub>H</sub> - FFFF<sub>H</sub>) XRAM has to be disabled. When additional external RAM is to be addressed in an address range ≤ XRAM (F800<sub>H</sub>) XRAM may remain being enabled and there is no need to overwrite XPAGE by a second move.



**Figure 3-3**  
**Write Page Address to XPAGE**

The page address is only written to XPAGE-register. Port 2 is available for addresses or I/O-Data. See **figure 3-4** to see what happens when Port 2 is used as I/O-Port.



**Figure 3-4**  
**Use of Port 2 as I/O-Port**

At a write to Port 2, XRAM address in XPAGE-register will be overwritten because of the concurrent write to Port 2 and XPAGE-register. So whenever XRAM is used and the XRAM address differs from the byte written to Port 2 latch it is absolutely necessary to rewrite XPAGE with page address.

**Example:**

I/O-Data at Port 2 shall be 0AAH. A Byte shall be fetched from XRAM at address 0F830<sub>H</sub>

```

MOV R0, #30H
MOV P2, #0AAH           ; P2 shows 0AAH
MOV XPAGE, #0F8H       ; P2 still shows 0AAH but XRAM is addressed
MOVX A, @R0            ; the contents of XRAM at 0F830H is moved to accu
    
```

The register XPAGE provides the upper address byte for accesses to XRAM with MOVX @Ri instructions. If the address formed from XPAGE and Ri is less than the XRAM address range, then an external access is performed. For the SAB 80C517A the contents of XPAGE must be greater or equal than F8<sub>H</sub> in order to use the XRAM. Of course, the XRAM must be enabled if it shall be used with MOVX @Ri instructions.

Thus, the register XPAGE is used for addressing of the XRAM; additionally its contents are used for generating the internal XRAM select. If the contents of XPAGE is less than the XRAM address range then an external bus access is performed where the upper address byte is provided by P2 and not by XPAGE!

Therefore, the software has to distinguish two cases, if the MOVX @Ri instructions with paging shall be used:

- a) Access to XRAM:                      The upper address byte must be written to XPAGE or P2; both writes selects the XRAM address range.
- b) Access to external memory:        The upper address byte must be written to P2; XPAGE will be loaded with the same address in order to deselect the XRAM.

The behaviour of Port0, Port2 and the  $\overline{RD}/\overline{WR}$  signals depends on the state of pin  $\overline{EA}$  and on the control bits XMAP0 and XMAP1 in register SYSCON.

### 3.4.2 Control of XRAM in the SAB 80C517A

There are two control bits in register SYSCON which control the use and the bus operation during accesses to the additional On-Chip RAM in XDATA range ( $\Delta$  XRAM).

#### Special Function Register SYSCON

	MSB						LSB		
Bit No.	7	6	5	4	3	2	1	0	
Addr. 0B1 <sub>H</sub>	-	-	-	-	-	-	XMAP1	XMAP0	SYSCON

Bit	Function
XMAP0	Global enable/disable bit for XRAM memory. XMAP0 = 0: The access to XRAM (= On-Chip XDATA memory) is enabled. XMAP0 = 1: The access to XRAM is disabled. All MOVX accesses are performed by the external bus.
XMAP1	Control bit for $\overline{RD}/\overline{WR}$ signals during accesses to XRAM; this bit has no effect if XRAM is disabled (XMAP0 = 1) or if addresses outside the XRAM address range are used for MOVX accesses. XMAP1 = 0: The signals $\overline{RD}$ and $\overline{WR}$ are not activated during accesses to XRAM. XMAP1 = 1: The signals $\overline{RD}$ and $\overline{WR}$ are activated during accesses to XRAM.

Reset value of SYSCON is XXXX XX01B.

The control bit XMAP0 is a global enable/disable bit for the additional On-Chip RAM (XRAM). If this bit is set, the XRAM is disabled, all MOVX accesses use external memory via the external bus. In this case the SAB80C517A can't use the additional On-Chip RAM and is compatible with the types without XRAM.

A hardware protection is done by an unsymmetric latch at XMAP0-bit. A unintentional disabling of XRAM could be dangerous since indeterminate values could be read from external bus. To avoid this the XMAP-bit is forced to '1' only by reset. Additionally during reset an internal capacitor is loaded. So the reset state is a disabled XRAM. Because of the load time of the capacitor XMAP0-bit once written to '0' (that is, discharging capacitor) cannot be set to '1' again by software. On the other hand any distortion (software hang up, noise,...) is not able to load this capacitor, too. That is, the stable status is XRAM enabled. The only way to disable XRAM after it was enabled is a reset.

The clear instruction for the XMAP0-bit should be integrated in the program initialization routine before XRAM is used. In extremely noisy systems the user may have redundant clear instructions.

The control bit XMAP1 is relevant only if the XRAM is accessed. In this case the external  $\overline{RD}$  and  $\overline{WR}$  signals at P3.6 and P3.7 are not activated during the access, if XMAP1 is cleared. For debug purposes it might be useful to have these signals available. This is performed if XMAP1 is set.

### 3.4.3 Behaviour of Port0 and Port2

The behaviour of Port 0 and P2 during a MOVX access depends on the control bits in register SYSCON and on the state of pin  $\overline{EA}$ . The **table 3-3** lists the various operating conditions. It shows the following characteristics:

- a) Use of P0 and P2 pins during the MOVX access.
  - Bus: The pins work as external address/data bus. If (internal) XRAM is accessed, the data read from the XRAM can not be seen on the bus.
  - I/O: The pins work as Input/Output lines under control of their latch.
- b) Activation of the  $\overline{RD}$  and  $\overline{WR}$  pin during the access.
- c) Use of internal or external XDATA memory.

The shaded areas describe the standard operation as each 80C51 device without on-chip XRAM behaves.



		EA = 0			EA = 1		
		XMAP1, XMAP0			XMAP1, XMAP0		
		00	10	X1	00	10	X1
MOVX @DPTR	DPTR < XRAM address range	a) P0/P2 → Bus b) RD/WR active c) ext. memory is used	a) P0/P2 → Bus b) RD/WR active c) ext. memory is used	a) P0/P2 → Bus b) RD/WR active c) ext. memory is used	a) P0/P2 → Bus b) RD/WR active c) ext. memory is used	a) P0/P2 → Bus b) RD/WR active c) ext. memory is used	a) P0/P2 → Bus b) RD/WR active c) ext. memory is used
	DPTR ≥ XRAM address range	a) P0/P2 → Bus (WR-Data only) b) RD/WR inactive c) XRAM is used	a) P0/P2 → Bus (WR-Data only) b) RD/WR active c) XRAM is used	a) P0/P2 → Bus b) RD/WR active c) ext. memory is used	a) P0/P2 → I/O b) RD/WR inactive c) XRAM is used	a) P0/P2 → Bus (WR-Data only) b) RD/WR active c) XRAM is used	a) P0/P2 → Bus b) RD/WR active c) ext. memory is used
MOVX @ Ri	XPAGE < XRAM addr.page range	a) P0 → Bus P2 → I/O b) RD/WR active c) ext. memory is used	a) P0 → Bus P2 → I/O b) RD/WR active c) ext. memory is used	a) P0 → Bus P2 → I/O b) RD/WR active c) ext. memory is used	a) P0 → Bus P2 → I/O b) RD/WR active c) ext. memory is used	a) P0 → Bus P2 → I/O b) RD/WR active c) ext. memory is used	a) P0 → Bus P2 → I/O b) RD/WR active c) ext. memory is used
	XPAGE ≥ XRAM addr.page range	a) P0 → Bus (WR-Data only) P2 → I/O b) RD/WR inactive c) XRAM is used	a) P0 → Bus (WR-Data only) P2 → I/O b) RD/WR active c) XRAM is used	a) P0 → Bus P2 → I/O b) RD/WR active c) ext. memory is used	a) P0/P2 → I/O b) RD/WR inactive c) XRAM is used	a) P0 → Bus (WR-Data only) P2 → I/O b) RD/WR active c) XRAM is used	a) P0 → Bus P2 → I/O b) RD/WR active c) ext. memory is used

modes compatible to 8051-family

Table 3-3: Behaviour of P0/P2 and RD/WR During MOVX Accesses

## 4 System Reset

### 4.1 Additional Hardware Power Down Mode in the SAB 80C517A

The SAB 80C517A has an additional Power Down Mode which can be initiated by an external signal at a dedicated pin. This pin is labeled  $\overline{\text{HWPD}}$  and is a floating input line (active low). This pin substitutes one of the VSS pins of the base types SAB 80C517 (PLCC84: Pin60; P-MQFP-100-2: Pin36). Because this new power down mode is activated by an external hardware signal this mode is referred to as Hardware Power Down Mode in opposite to the program controlled Software Power Down Mode.

For a correct function of the Hardware Power Down Mode the oscillator watchdog unit including its internal RC oscillator is needed. Therefore this unit must be enabled by pin OWE (OWE = High), if the Hardware Power Down Mode shall be used. However, the control pin  $\overline{\text{PE}}/\text{SWD}$  has no control function for the Hardware Power Down Mode; it enables and disables only the use of all software controlled power saving modes (Slow Down Mode, Idle Mode, Software Power Down Mode).

The function of the new Hardware Power Down Mode is as follows:

The pin  $\overline{\text{HWPD}}$  controls this mode. If it is on logic high level (inactive) the part is running in the normal operating modes. If pin  $\overline{\text{HWPD}}$  gets active (low level) the part enters the Hardware Power Down Mode; as mentioned above this is independent of the state of pin  $\overline{\text{PE}}/\text{SWD}$ .

$\overline{\text{HWPD}}$  is sampled once per machine cycle. If it is found active, the device starts a complete internal reset sequence. This takes two machine cycles; all pins have their default reset states during this time. This reset has exactly the same effects as a hardware reset; i.e. especially the watchdog timer is stopped and its status flag WDTS is cleared. In this phase the power consumption is not yet reduced. After completion of the internal reset both oscillators of the chip are disabled, the on-chip oscillator as well as the oscillator watchdog's RC oscillator. At the same time the port pins and several control lines enter a floating state as shown in **table 4-1**. In this state the power consumption is reduced to the power down current IPD. Also the supply voltage can be reduced.

**Table 4-1** also lists the voltages which may be applied at the pins during Hardware Power Down Mode without affecting the low power consumption.

**Table 4-1, Status of all Pins During Hardware Power Down Mode**

Pins	Status	Voltage Range at Pin During HW-Power Down
P0, P1, P2, P3, P4, P5, P6, P7, P8	Floating outputs / Disabled input function	$V_{SS} \leq V_{IN} \leq V_{CC}$
$\overline{EA}$	active input	$V_{IN} = V_{CC}$ or $V_{IN} = V_{SS}$
$\overline{PE}/SWD$	active input, Pull-up resistor disabled during HW power down	$V_{IN} = V_{CC}$ or $V_{IN} = V_{SS}$
XTAL1	active output	pin may not be driven
XTAL2	disabled input function	$V_{SS} \leq V_{IN} \leq V_{CC}$
$\overline{PSEN}$ , ALE	Floating outputs / Disabled input function (for test modes only)	$V_{SS} \leq V_{IN} \leq V_{CC}$
VAREF, VAGND	active supply pins	$V_{AGnd} \leq V_{IN} \leq V_{CC}$
OWE	active input; must be at high level for start-up after HW PD; pull up resistor disabled during HW-power down	$V_{IN} = V_{CC}$ or $(V_{IN} = V_{SS})$
Reset	active input; must be on high level if HW PD is used	$V_{IN} = V_{CC}$
$\overline{R0}$	Floating output	$V_{SS} \leq V_{IN} \leq V_{CC}$

The power down state is maintained while pin  $\overline{\text{HWPD}}$  is held active. If HWPD goes to high level (inactive state) an automatic start up procedure is performed:

- First the pins leave their floating condition and enter their default reset state as they had immediately before going to float state.
- Both oscillators are enabled (only if OWE = high). While the on-chip oscillator (with pins XTAL1 and XTAL2) usually needs a longer time for start-up, if not externally driven (with crystal approx. 1 ms), the oscillator watchdog's RC oscillator has a very short start-up time (typ. less than 2 microseconds).
- Because the oscillator watchdog is active it detects a failure condition if the on-chip oscillator hasn't yet started. Hence, the watchdog keeps the part in reset and supplies the internal clock from the RC oscillator.
- Finally, when the on-chip oscillator has started, the oscillator watchdog releases the part from reset after it performed a final internal reset sequence and switches the clock supply to the on-chip oscillator. This is exactly the same procedure as when the oscillator watchdog detects first a failure and then a recovering of the oscillator during normal operation. Therefore, also the oscillator watchdog status flag is set after restart from Hardware Power Down Mode.

When automatic start of the watchdog was enabled ( $\overline{\text{PE}}/\text{SWD}$  connected to  $V_{\text{CC}}$ ), the Watchdog Timer will start, too (with its default reload value for time-out period).

The SWD-Function of the  $\overline{\text{PE}}/\text{SWD}$  Pin is sampled only by a hardware reset. Therefore at least one Power On Reset has to be performed.

#### 4.2 Hardware Power Down Reset Timing

Following figures are showing the timing diagrams for entering (**figure 4-1**) and leaving (**figure 4-2**) the Hardware Power Down Mode. If there is only a short signal at pin  $\overline{\text{HWPD}}$  (i.e.  $\overline{\text{HWPD}}$  is sampled active only once), then a complete internal reset is executed. Afterwards the normal program execution starts again (**figure 4-3**).

**Note:**

Delay time caused by internal logic is not included.

The  $\overline{\text{Reset}}$  pin overrides the Hardware Power Down function, i.e. if reset gets active during Hardware Power Down it is terminated and the device performs the normal reset function. Thus, pin  $\overline{\text{Reset}}$  has to be inactive during Hardware Power Down Mode.

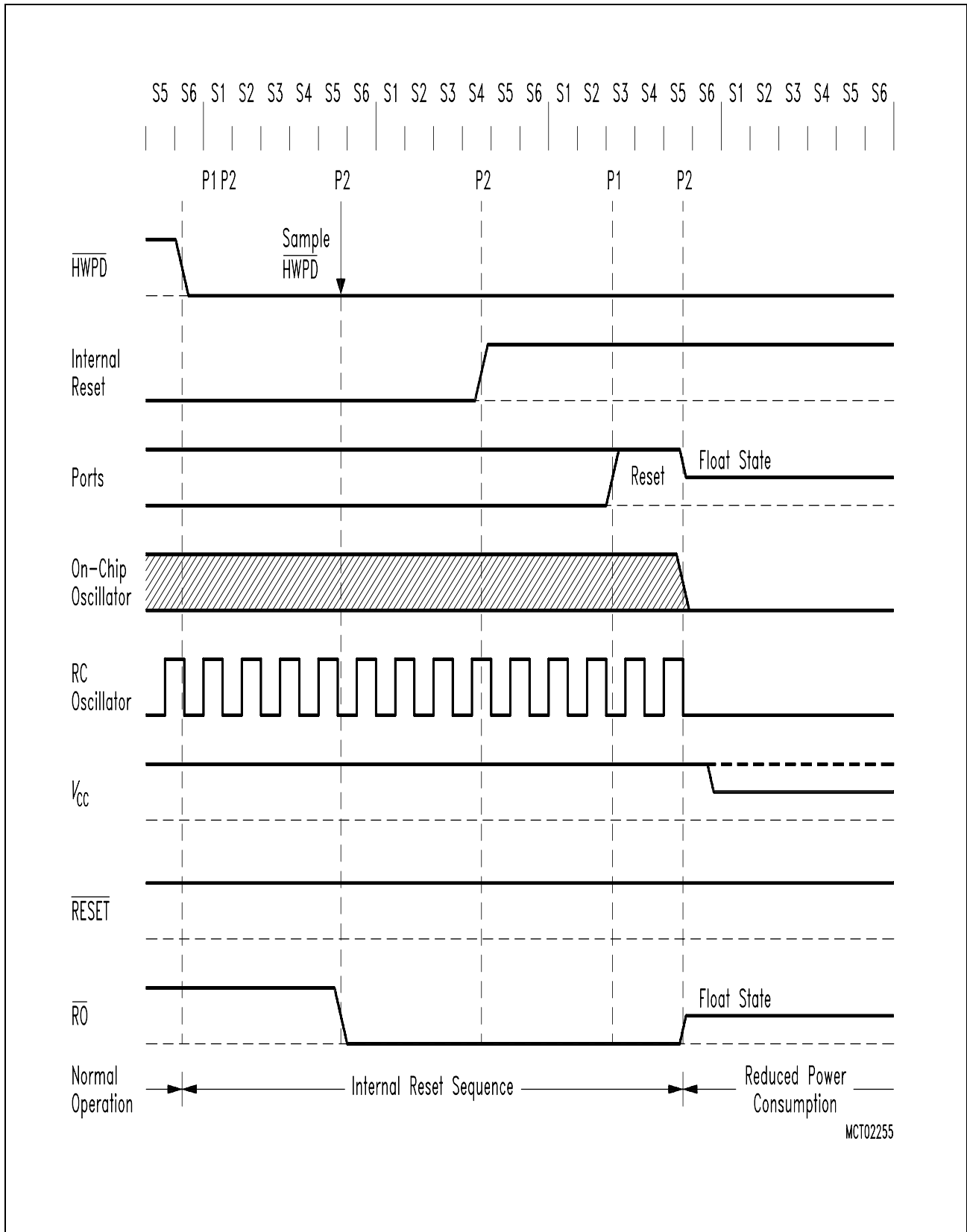
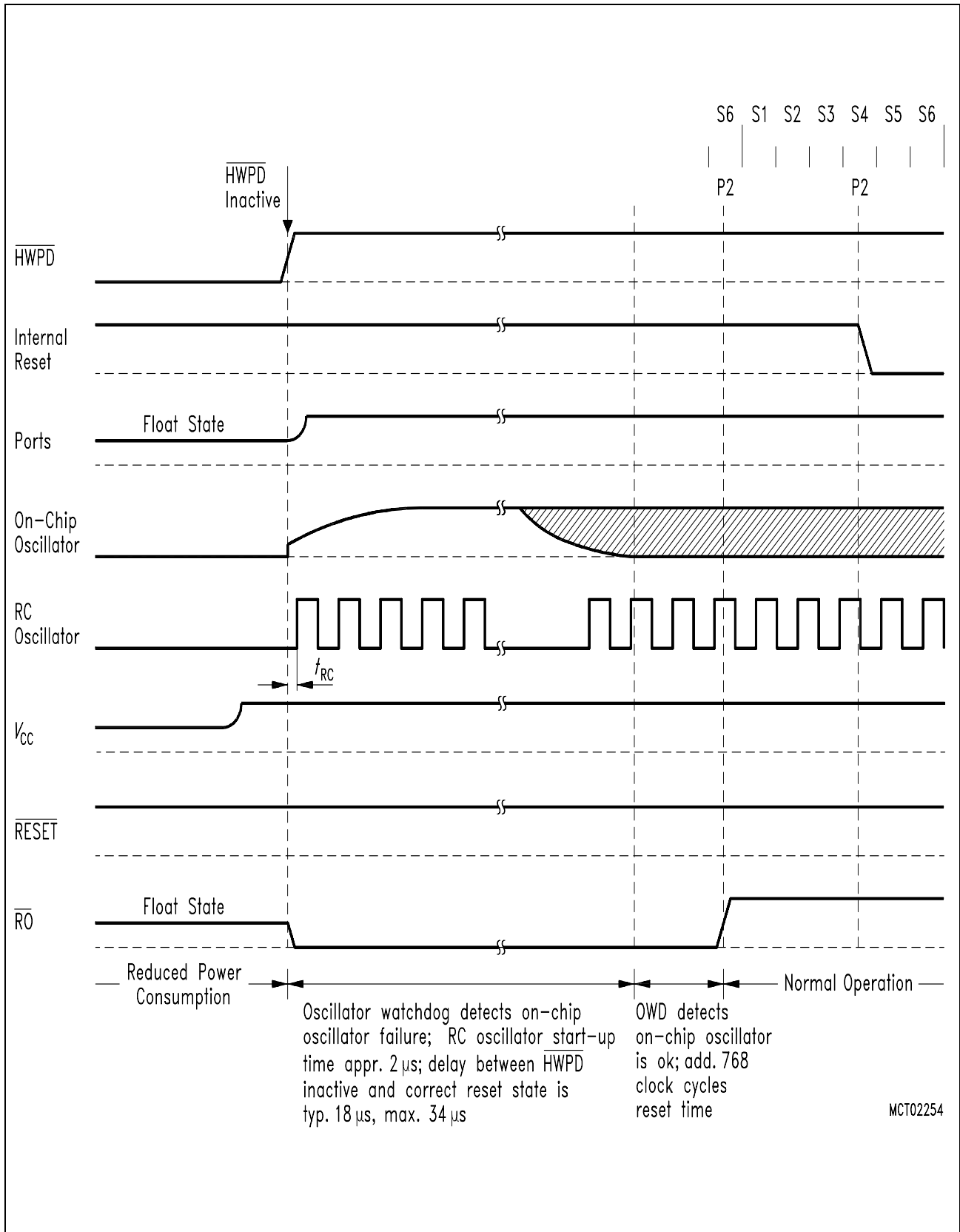
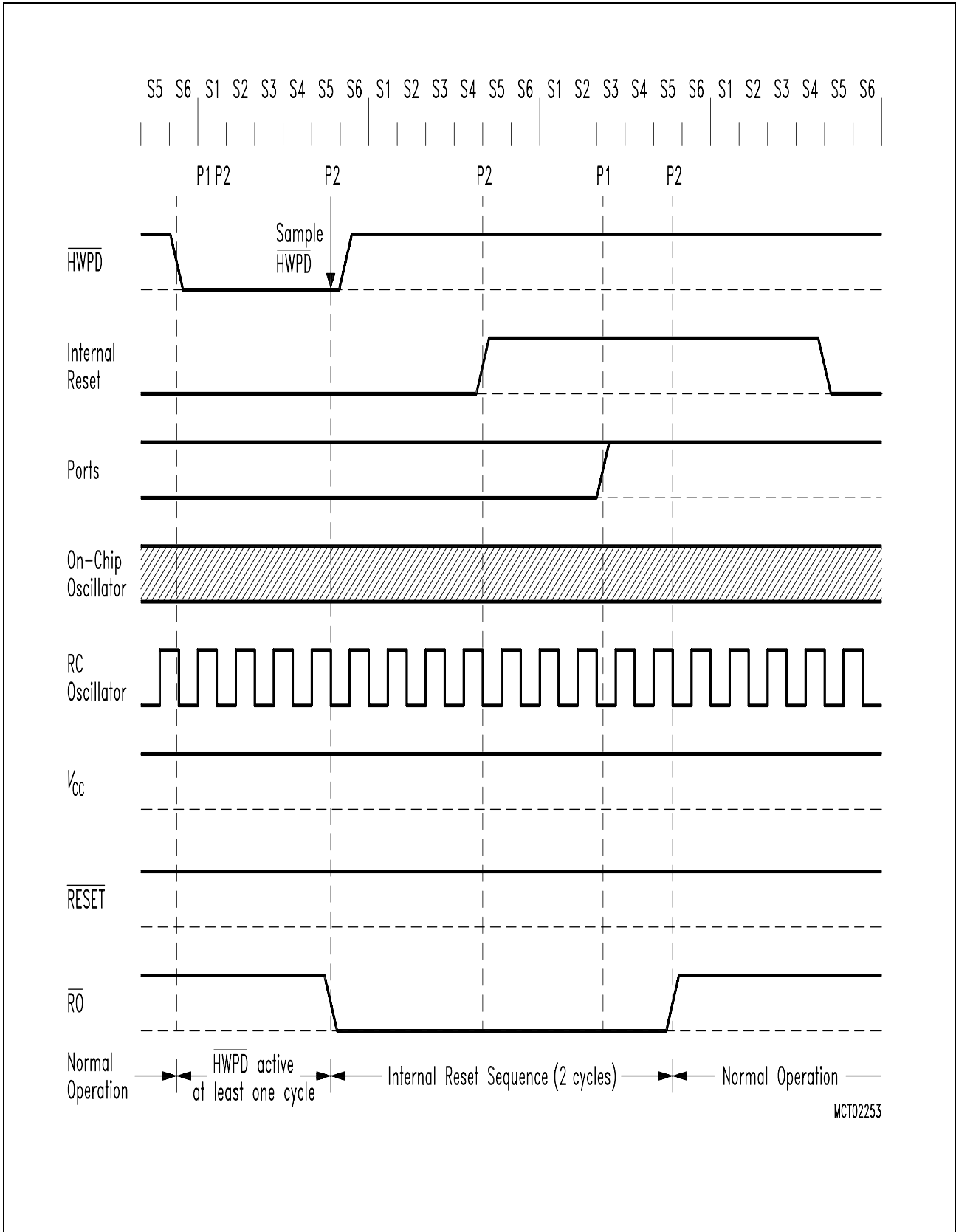


Figure 4-1  
Timing Diagram of Entering Hardware Power Down Mode



**Figure 4-2**  
**Timing Diagram of Leaving Hardware Power Down Mode**



**Figure 4-3**  
**Timing Diagram of Hardware Power Down Mode, HYPD-Pin is Active for only one cycle**



### 4.3 Fast internal Reset after Power-On

The SAB 80C517A can use the oscillator watchdog unit for a fast internal reset procedure after power-on.

**Figure 4-4** shows the power-on sequence under control of the oscillator watchdog.

Normally the devices of the 8051 family (like the SAB 80C517) enter their default reset state not before the on-chip oscillator starts. The reason is that the external reset signal must be internally synchronized and processed in order to bring the device into the correct reset state. Especially if a crystal is used the start up time of the oscillator is relatively long (typ. 1ms). During this time period the pins have an undefined state which could have severe effects especially to actuators connected to port pins.

In the SAB 80C517A the oscillator watchdog unit can avoid this situation. For doing this, the oscillator watchdog must be enabled. In this case, after power-on the oscillator watchdog's RC oscillator starts working within a very short start-up time (typ. less than 2 microseconds). In the following the watchdog circuitry detects a failure condition for the on-chip oscillator because this has not yet started (a failure is always recognized if the watchdog's RC oscillator runs faster than the on-chip oscillator). As long as this condition is detected the watchdog uses the RC oscillator output as clock source for the chip rather than the on-chip oscillator's output. This allows correct resetting of the part and brings also all ports to the defined state (**see figure 4-4, I**). The time period from power-on till reaching the reset state at the ports adds from the following terms:

- RC oscillator start-up < 2  $\mu$ s
- synchronization of the RC oscillators divider-by-5 < 6 T
- synchronization of the state and cycle counters < 6 T
- reset procedure till correct port states are reached < 12T

Delay between power-on and correct reset state:

Typ.: 18  $\mu$ s

Max.: 34  $\mu$ s

After the on-chip oscillator finally has started, the oscillator watchdog detects the correct function; then the watchdog still holds the reset active for a time period of 768 cycles of the RC oscillator in order to allow the oscillation of the on-chip oscillator to stabilize (**figure 4-4, II**). Subsequently the clock is supplied by the on-chip oscillator and the oscillator watchdog's reset request is released (**figure 4-4, III**). However, an externally applied reset still remains (**figure 4-4, IV**) active and the device does not start program execution (**figure 4-4, V**) before the external reset is also released.

Although the oscillator watchdog provides a fast internal reset it is additionally necessary to apply the external reset signal when powering up. The reasons are as follows:

- Termination of Hardware Power Down Mode (a  $\overline{\text{HWPD}}$  signal is overridden by reset)
- Termination of Software Power Down Mode
- Reset of the status flag OWDS that is set by the oscillator watchdog during the power up sequence.

The external reset signal must be hold active at least until the on-chip oscillator has started and the internal watchdog reset phase is completed. An external reset time of more than 5 ms should be sufficient in typical applications. If only a capacitor at pin  $\overline{\text{Reset}}$  is used a value of 100 nF provides the desired reset time.

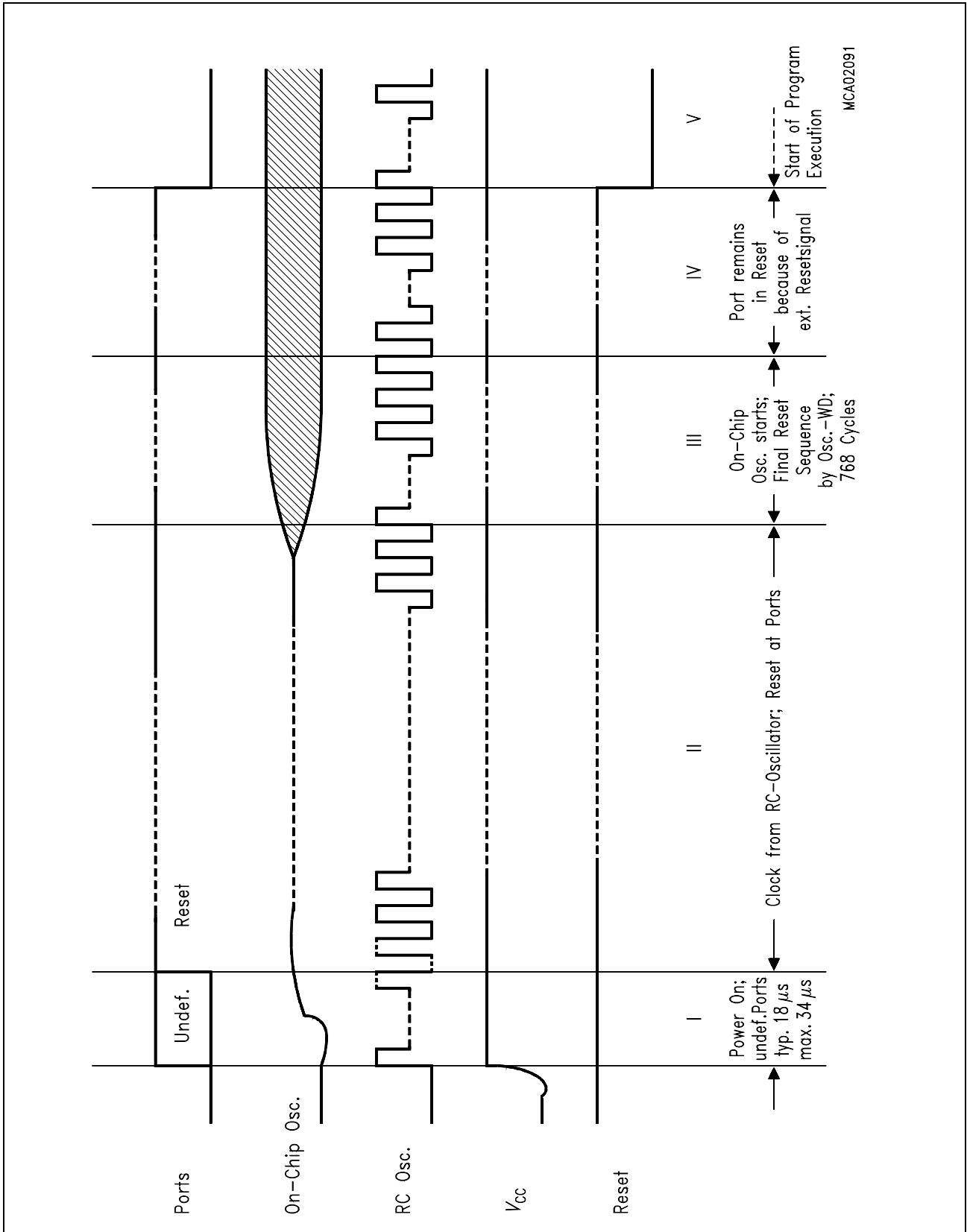


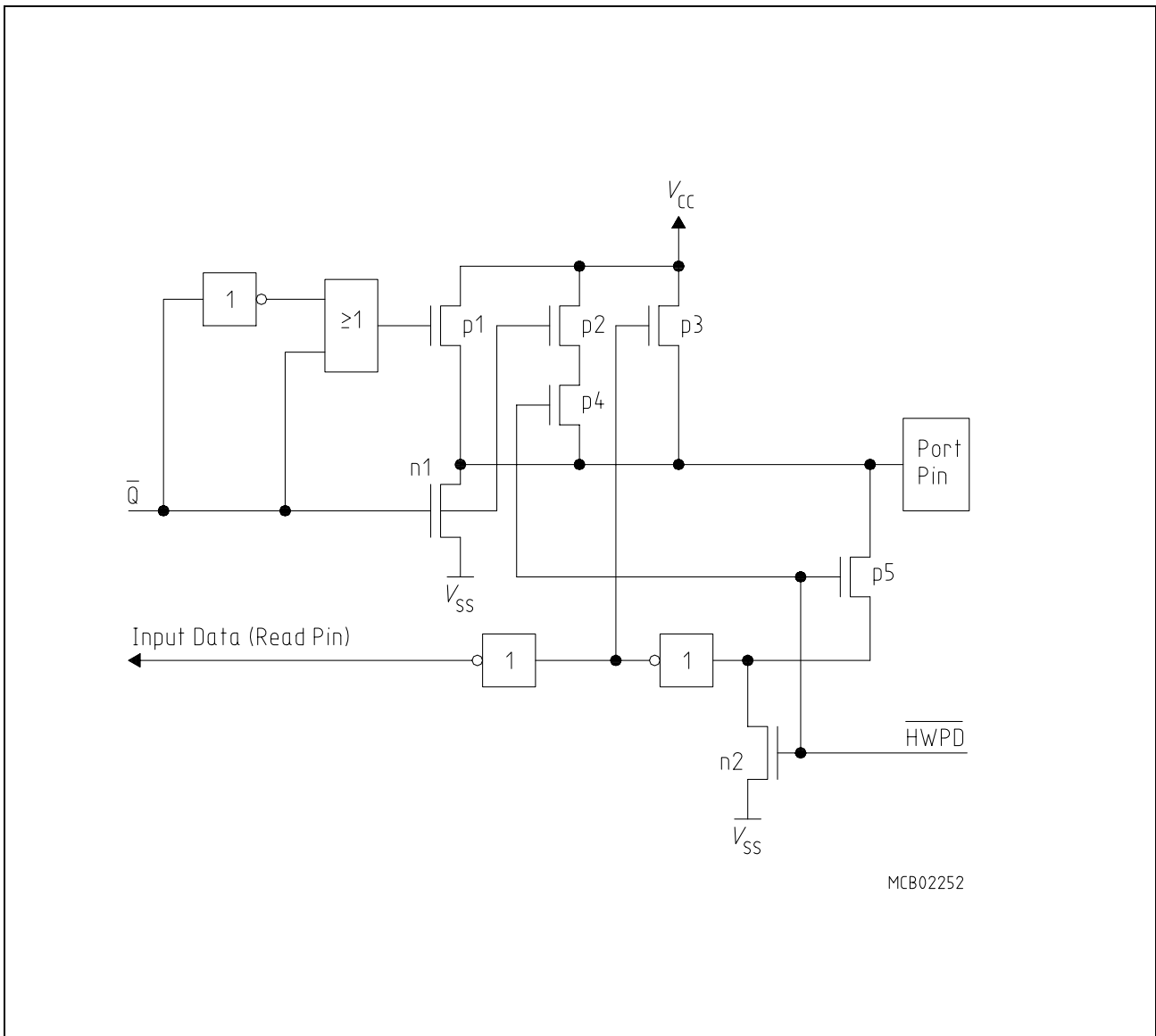
Figure 4-4  
Power-On of the SAB 80C517A

5 On-Chip Peripheral Components

5.1 Digital I/O Port Circuitry

To realize the Hardware Power Down Mode with floating Port pins in the SAB 80C517A/83C517A 5 the standard port structure used in the 8051 Family is modified (**figure 5-1**).

The FETs p4, p5 and n2 are added. During Hardware Power Down this FETs disconnect the port pins from internal logic.



**Figure 5-1**  
**Port Structure**

P1 and p3 are not active during Hardware Power Down.

P1 is activated only for two oscillator periods if a 0-to-1 transition is programmed to the port pin (not possible during HWPDP).

P3 is turned off during reset state (also HWPDP).

For detailed description of the port structure please refer to the SAB 80C517/80C537 User's Manual.

### 5.2 10-bit A/D-Converter

In the SAB 80C517A is a new high performance / high speed 12-channel 10-bit A/D-Converter is implemented. Its successive approximation technique provides 7  $\mu\text{s}$  conversion time ( $f_{\text{OSC}}=16 \text{ MHz}$ ). The conversion principle is upward compatible to the one used in the SAB 80C517. The major components are shown in **figure 5-1**.

The comparator is a fully differential comparator for a high power supply rejection ratio and very low offset voltages. The capacitor network is binary weighted providing 10-bit resolution.

The **table 5-1** below shows the sample time  $T_s$  and the conversion time  $T_c$  (including  $T_s$ ), which depend on  $f_{\text{OSC}}$  and the selected prescaler (see also Bit ADCL in SFR ADCON 1).

**Table 5-1, ADC-Conversion Time**

$f_{\text{OSC}}[\text{MHz}]$	Prescaler	$f_{\text{ADC}}[\text{MHz}]$	$T_s [\mu\text{s}]$	$T_c [\mu\text{s}]$ (incl. $T_s$ )
12	$\div 8$	1.5	1.33	8
	$\div 16$	0.75	2.8	16
16	$\div 8$	2.0	2.0	7.0
	$\div 16$	1.0	4.0	14.0
18	$\div 8$	—	—	—
	$\div 16$	1.125	3.555	12.4

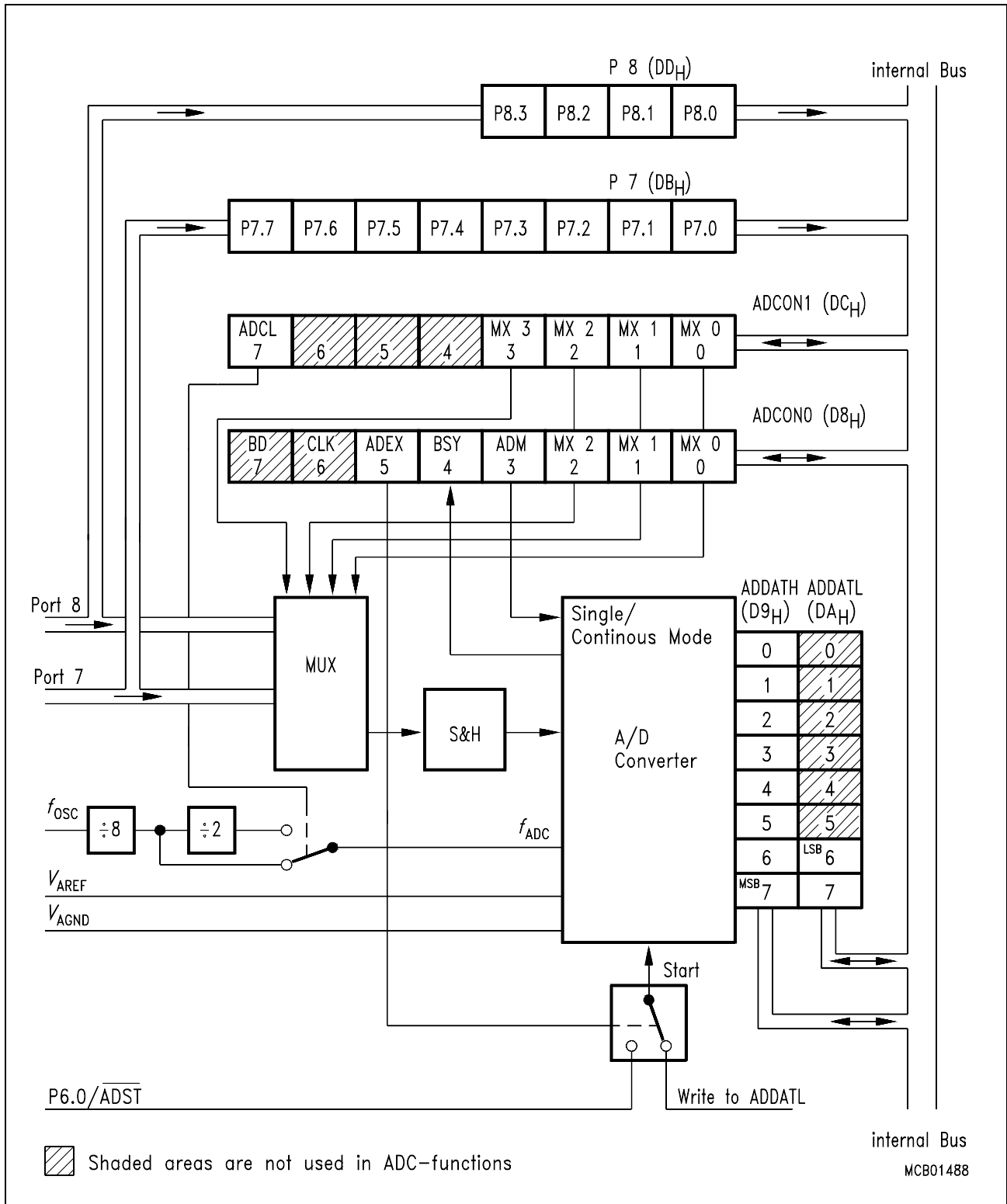
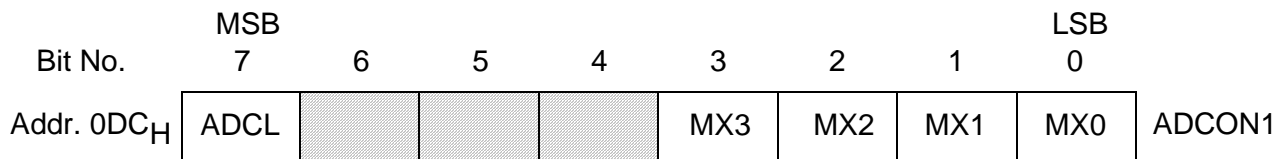
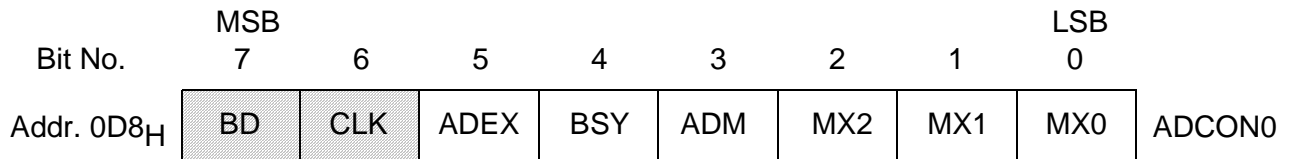



Figure 5-1  
10-Bit A/D-Converter

## Special Function Registers ADCON0, ADCON1



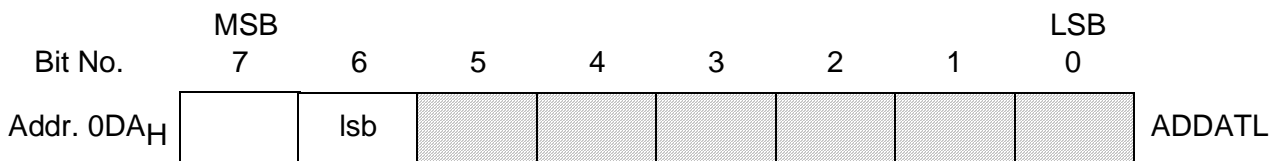
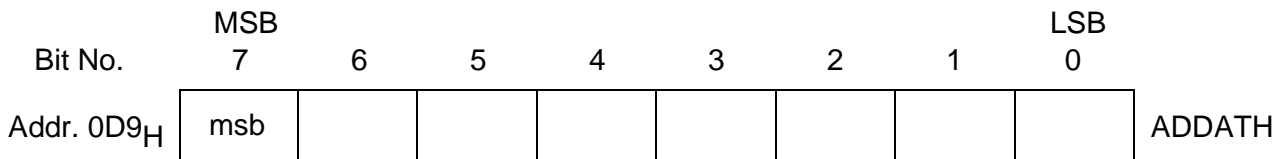
 These bits are not used in controlling A/D converter functions in the 80C517A


Bit	Function
ADEX	Internal / external start of conversion. When set, the external start of conversion by P6.0 / $\overline{ADST}$ is enabled.
BSY	Busy flag. This flag indicates whether a conversion is in progress (BSY = 1). The flag is cleared by hardware when the conversion is finished.
ADM	A/D Conversion mode. When set, a continuous conversion is selected. If cleared, the converter stops after one conversion.
MX3 - MX0	Select 12 input channels of the ADC. Bits MX0 to MX2 can be written or read either in ADCON0 or in ADCON1.
ADCL	ADC Clock. When set $f_{ADC} = f_{OSC} / 16$ . Has to be set when $f_{OSC} > 16$ MHz

The reset value of ADCON0 and ADCON1 is 00<sub>H</sub>



## Special Function Register ADDATH, ADDATL



 These bits are not used for conversion result

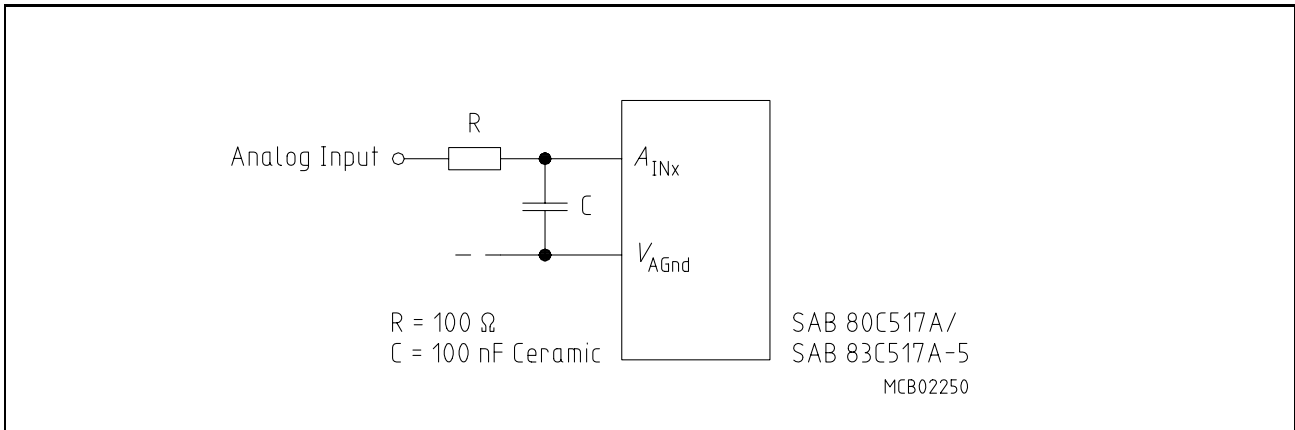
The reset value of ADDATH and ADDATL is 00<sub>H</sub>.

The registers **ADDATH** (0D9H) and **ADDATL** (0DAH) contain the 10-bit conversion result. The data is read as two 8-bit bytes. Data is presented in left justified format (i.e. the msb is the most left-hand bit in a 16-bit word). To get a 10-bit conversion result two READ operations are required. Otherwise ADDATH contains the 8-bit conversion result.

## A/D Converter Timing

After a conversion has been started (by a write to ADDATL, external start by P6.0/ $\overline{\text{ADST}}$  or in continuous mode) the analog input voltage is sampled for 4 clock cycles. The analog source must be capable of charging the capacitor network of appr. 50 pF to full accuracy in this time. During this period the converter is susceptible to spikes and noise at the analog input, which may cause wrong codes at the digital outputs. Therefore RC-filtering at the analog inputs is recommended (see **figure 5-2** below).

Conversion of the sampled analog voltage takes place between the 4th and 14th clock cycle.



**Figure 5-2**  
**Recommended RC-filtering at the Analog Inputs**

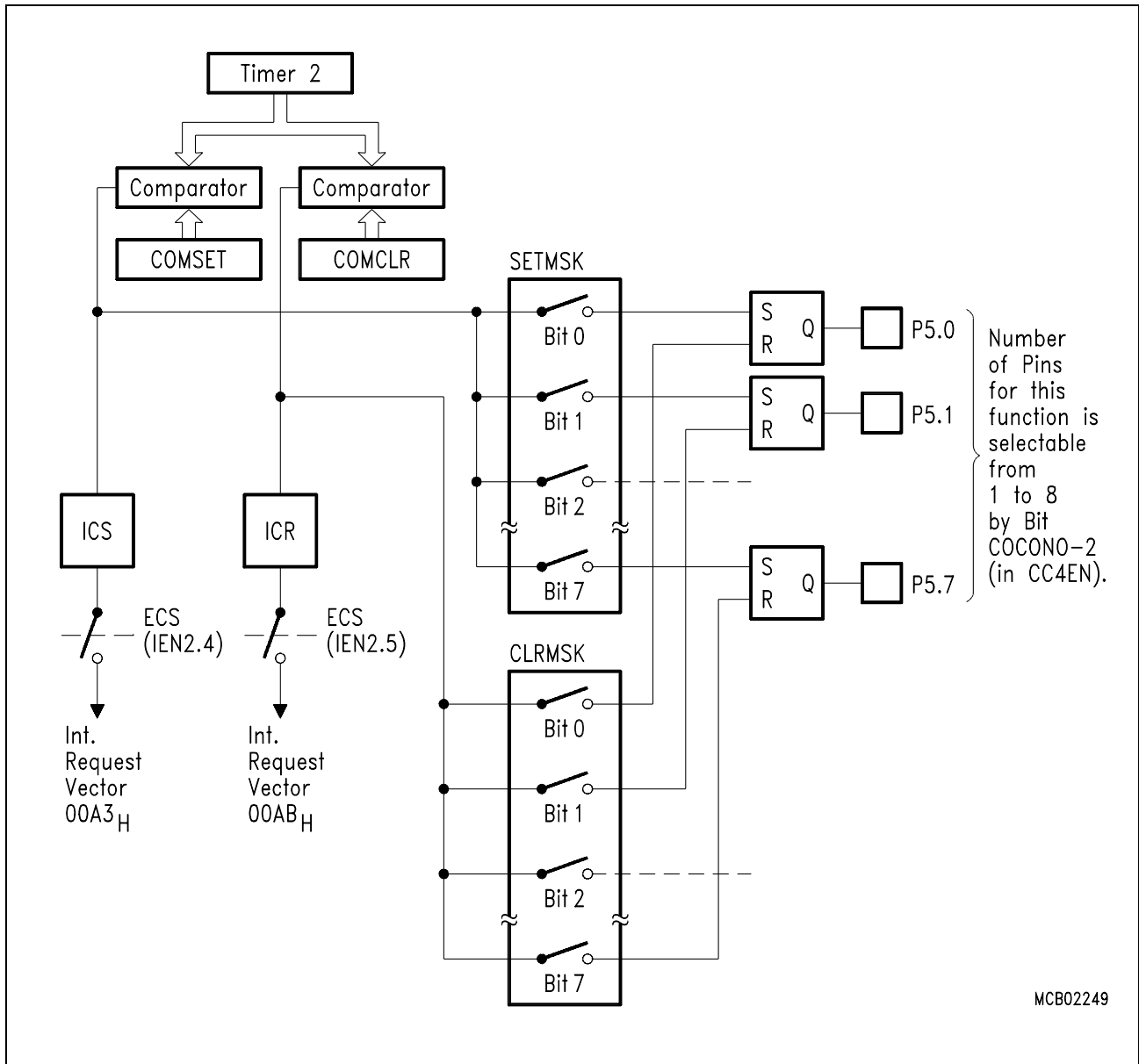
### 5.3 Additional Compare Mode for the Concurrent Compare Unit

The SAB 80C517A has an additional compare mode (compare mode 2) in the Compare/Capture Unit which can be used for the Concurrent Compare Output at P5. In this compare mode 2 the P5 pins are no longer general purpose I/O pins or under control of compare/capture register CC4, but under control of the new compare registers COMSET and COMCLR. These both 16-bit registers are always associated with Timer 2 (same as CRC, CC1 to CC4). Each of these registers consists of two 8-bit portions, i.e COMSET consists of COMSETL (address 0A1H) and COMSETH (address 0A2H), COMCLR consists of COMCLRL (address 0A3H) and COMCLRHL (address 0A4H)

In compare mode 2 the concurrent compare output pins on Port 5 are used as follows (see figure 5-3):

- When a compare match occurs with register COMSET, a high level appears at the pins of port 5 whose corresponding bits in the mask register SETMSK (address 0A5H) are set.
- When a compare match occurs in register COMCLR, a low level appears at the pins of port 5 whose corresponding bits in the mask register CLRMSK (address 0A6H) are set.
- Additionally the Port 5 pins used for compare mode 2 may also be directly written to by write instructions to SFR P5. Of course, the pins can also be read under program control.

If compare mode 2 shall be selected register CC4 must operate in compare mode 1 (with the corresponding output pin P1.4); thus, compare mode 2 is selected by enabling compare function for register CC4 (COCAH4=1; COCAL4=0 SFR CC4EN) and by programming bits COCOEN0 and COCOEN1 in SFR CC4EN. Like in concurrent compare mode associated with CC4, the number of port pins at P5 which serve the compare output function can be selected by bits COCON0-COCON2 (in SFR CC4EN). If a set and reset request occurs at the same time (identical values in COMSET and COMCLR), the set operation takes precedence. It is also possible to use only the interrupts which are generated by matches in COMSET and COMCLR without affecting P5 ("software compare"). For this "interrupt-only" mode it is not necessary that the compare function at CC4 is selected.



**Figure 5-3**  
**Compare Mode 2 (Port 5 only)**

## Special Function Register CC4EN

Bit No.	MSB							LSB	
	7	6	5	4	3	2	1	0	
0C9 <sub>H</sub>	COCOEN1	COCON2	COCON1	COCON0	COCOEN0	COCAH4	COCAL4	COM0	CC4EN

Bit	Function
COCON2 COCON1 COCON0	Selects number of compare outputs at P5 (for compare modes 1 and 2); <b>see table 2-2</b>
COCAH4 COCAL4  0      0 0      1 1      0 1      1	Compare/capture mode for register CC4 and compare modes 1 and 2 at P5 Compare/capture at CC4 disabled Capture on falling/rising edge at pin P1.4/ $\overline{INT2}$ /CC4 Compare enabled at CC4 Capture on write operation into register CCL4
COCOEN1 COCOEN0	Selection of compare modes 1 and 2 at P5; valid only in combination with certain configurations in COCAH4, COCAL4; <b>see table 2-3</b> Setting of bit COCOEN0 automatically sets COM0
COM0	Compare Mode for register CC4 COM0 = 0 selects compare mode 0 COM0 = 1 selects compare mode 1 Setting of bit COCOEN0 automatically sets COM0

The reset value of SFR CC4EN is 00<sub>H</sub>.

COCON2	COCON1	COCON0	Function
0	0	0	One additional output of CC4 at P5.0
0	0	1	Additional outputs of CC4 at P5.0 to P5.1
0	1	0	Additional outputs of CC4 at P5.0 to P5.2
0	1	1	Additional outputs of CC4 at P5.0 to P5.3
1	0	0	Additional outputs of CC4 at P5.0 to P5.4
1	0	1	Additional outputs of CC4 at P5.0 to P5.5
1	1	0	Additional outputs of CC4 at P5.0 to P5.6
1	1	1	Additional outputs of CC4 at P5.0 to P5.7

**Table 5-3, Configurations for Concurrent Compare Mode and Compare Mode 2 at P5**

COCAH4	COCAL4	COCOEN1	COCOEN0	Function of CC4	Function of Compare Modes at P5
0	0	0	0	Compare / Capture disabled	Disabled
0	0	1	0	Compare / Capture disabled	Compare mode 2 selected, but only interrupt generation (ICR, ICS); no output signals
0	0	1	1	Compare / Capture disabled	Compare Mode 2 selected at P5
0	1	0	0	Capture on falling/rising edge at pin P1.4/INT2/CC4	Disabled
0	1	1	0	–	Compare modes 2 selected, but only interrupt generation (ICR, ICS); no output signals at P5
1	0	0	0	Compare enable at CC4; Mode 0 <sub>1</sub> is selected by COM0	Disabled
1	0	0	1	Compare mode 1 enabled at CC4; COM0 is automatically set	Concurrent compare (mode 1) selected at P5
1	0	1	0	Compare enable at CC4; mode 0 <sub>1</sub> is selected by COM0	Compare mode 2 selected, but only interrupt generation (ICR, ICS); no output signals at P5
1	0	1	1	Compare mode 1 enabled at CC4; COM0 is automatically set	Compare Mode 2 selected at P5
1	1	0	0	Capture on write operation into register CCL4	Disabled
1	1	1	0	Capture on write operation into register CCL4	Compare mode 2 selected, but only interrupt generation (ICR, ICS); no output signals at P5

The other combinations are reserved and must not be used.

The following **table 5-4** lists the SFR's with their addresses and default values after reset which are used in compare mode 2:

**Table 5-4, Compare Mode 2, used SFR's and their default Reset Value**

SFR	Address	Default Value after Reset
COMSETL	0A1 <sub>H</sub>	00 <sub>H</sub>
COMSETH	0A2 <sub>H</sub>	00 <sub>H</sub>
COMCLRL	0A3 <sub>H</sub>	00 <sub>H</sub>
COMCLRH	0A4 <sub>H</sub>	00 <sub>H</sub>
SETMSK	0A5 <sub>H</sub>	00 <sub>H</sub>
CLRMSK	0A6 <sub>H</sub>	00 <sub>H</sub>
CTCON	0E1 <sub>H</sub>	0X00 0000 <sub>B</sub>
CC4EN	0C9 <sub>H</sub>	00 <sub>H</sub>

The compare registers COMSET and COMCLR have their dedicated interrupt vectors. The corresponding request flags are ICS for register COMSET and ICR for register COMCLR. The flags are set by a match in registers COMSET and COMCLR, when enabled. As long as the match condition is valid the request flags can't be reset (neither by hardware nor software). The request flags are located in SFR CTCON.

Special Function Register CTCON

Bit No.	MSB							LSB	
	7	6	5	4	3	2	1	0	
0BA <sub>H</sub>	T2PS1	–	ICR	ISC	CTF	CLK2	CLK1	CLK0	CTCON

Bit	Function
CLK0 CLK1 CLK2 CTF	Same function as SAB 80C517
ICS	Interrupt request flag for Compare register COMSET. ICS is set when a compare match occurred. Cleared when interrupt is processed.
ICR	Interrupt request flag for Compare register COMRES. ICR is set when a compare match occurred. Cleared when interrupt is processed.
T2PS1	Prescaler select bit for Timer 2. <b>See table 5-5</b>

The default value of CTCON after reset is 0X00 0000B

### Extended Prescaler for Timer 2

The prescaler for Timer 2 has an extended range. This prescaler divides the input clock for Timer 2 when it is operated in timer mode. In addition to the  $\div 2$  option there are now scale ratings of  $\div 4$  and  $\div 8$  available. The rate is selected by the control bits T2PS (T2CON.7) and T2PS1 (CTCON.7). **Table 5-5** lists all available options. This prescaler must not be used when Timer 2 is operated in counter mode.

**Table 5-5, Timer 2 Prescaler**

T2PS1 (CTCON.7)	T2PS (T2CON.7)	Prescaler Ratio
0	0	$\div 1$
0	1	$\div 2$
1	0	$\div 4$
1	1	$\div 8$

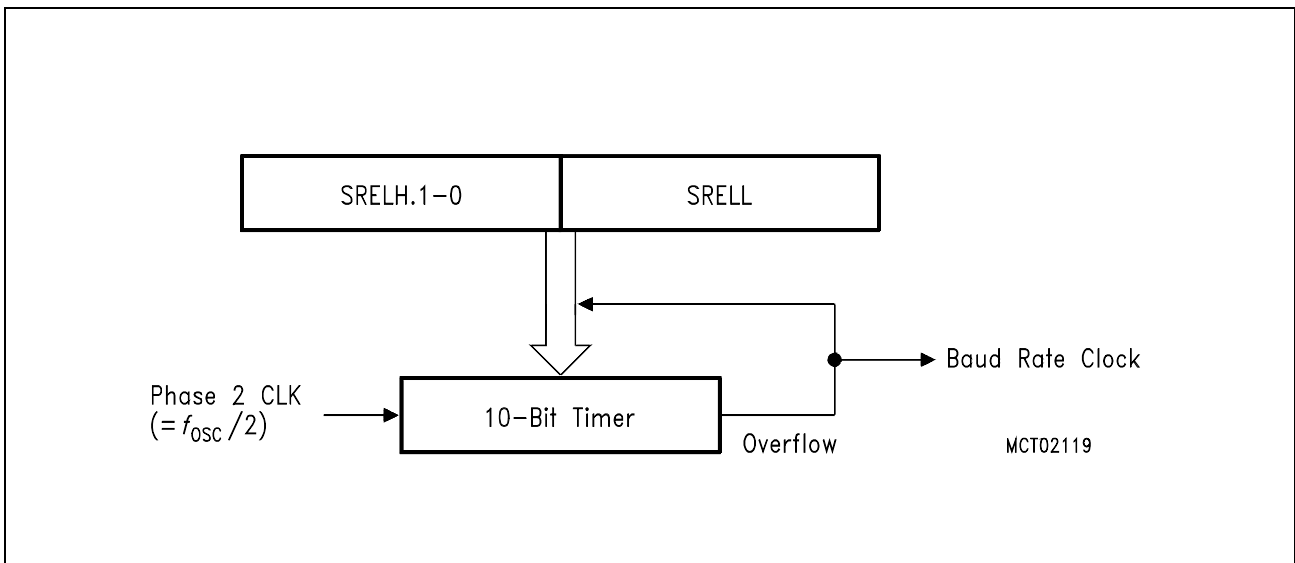


5.4 New Baud Rate Generators for Serial Channel 0 and Serial Channel 1

5.4.1 Serial Channel 0 Baud Rate Generator

The Serial Channel 0 has a new baud rate generator which provides greater flexibility and better resolution. It substitutes the 80C517's baud rate generator at Serial Channel 0 which provides only 4.8 kBaud or 9.6 kBaud at 12 MHz crystal frequency. Since the new generator offers greater flexibility it is often possible to use it instead of Timer1 which is then free for other tasks.

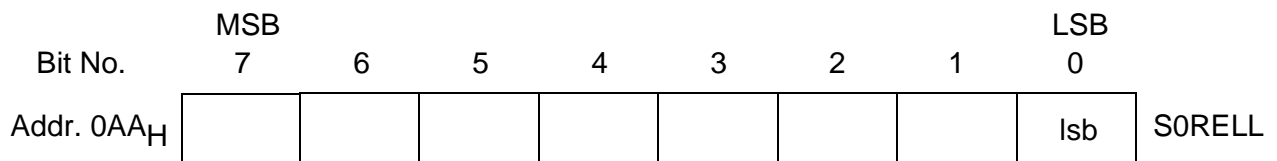
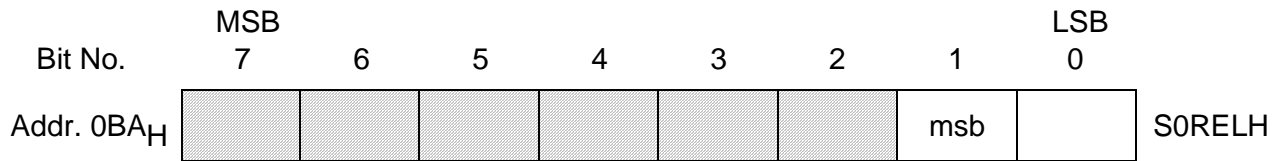
**Figure 5-4** shows a block diagram of the new baud rate generator for Serial Channel 0. It consists of a free running 10-bit timer with  $f_{OSC} / 2$  input frequency. On overflow of this timer there is an automatic reload from the registers S0RELL (address AA<sub>H</sub>) and S0RELH (address BA<sub>H</sub>). The lower 8 bits of the timer are reloaded from S0RELL, while the upper two bits are reloaded from bit 0 and 1 of register S0RELH. The baud rate timer is reloaded by writing to S0RELL.




**Figure 5-4**  
Baud Rate Generator for Serial Interface 0

The default value after reset of S0RELL is 0D9<sub>H</sub>, S0 RELH contains XXXX XX11B.

### Special Function Register S0RELH, S0RELL



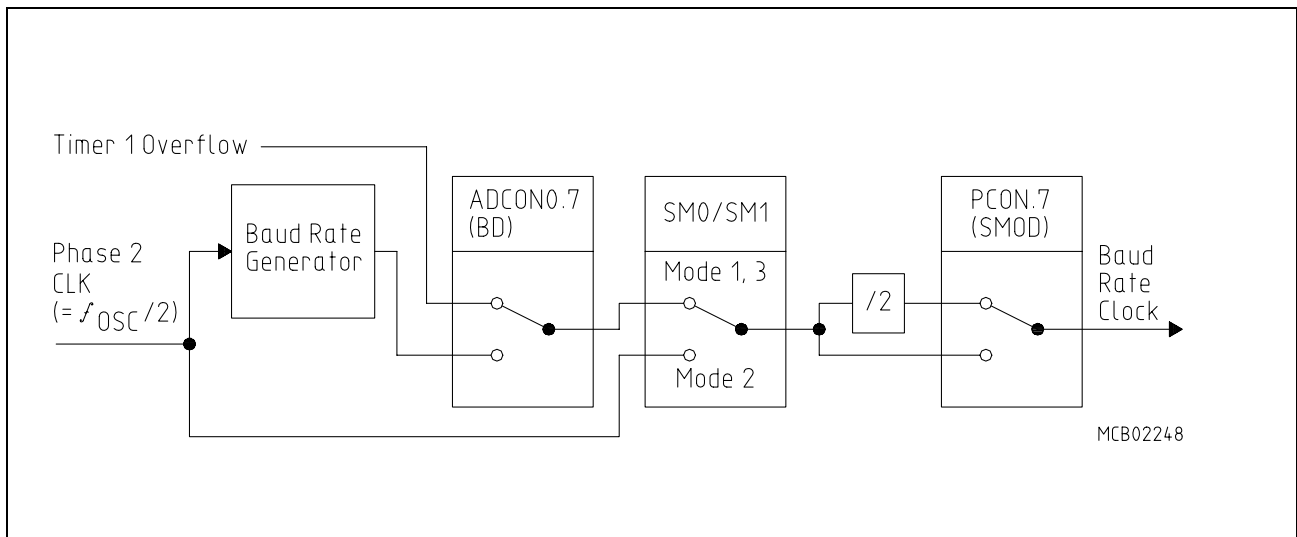
 shaded areas are not used for programming the baudrate timer

Bit	Function
S0RELH.0-1	Reload value. Upper two bits of the timer reload value.
S0RELL.0-7	Reload value. Lower 8 bit of timer reload value.

Reset value of S0RELL is 0D9<sub>H</sub>, S0RELH contains XXXX XXX11B.

**Figure 5-5** shows a block diagram of the options available for baud rate generation of Serial Channel 0. It is a fully compatible superset of the functionality of the SAB 80C517. The new baud rate generator can be used in modes 1 and 3 of the Serial Channel 0. It is activated by setting bit BD (ADCON0.7). This also starts the baud rate timer. When Timer1 shall be used for baud rate generation, bit BD must be cleared. In any case, bit SMOD (PCON.7) selects an additional divider by two.

The default values after reset in registers S0RELL and S0RELH provide a baud rate of 4.8 kBaud (with SMOD = 0) or 9.6 kBaud (with SMOD = 1) at 12 MHz oscillator frequency. This guarantees full compatibility to the SAB 80C517.



**Figure 5-5**  
**Block Diagram of Baud Rate Generation for Serial Interface 0**

If the new baud rate generator is used the baud rate of Serial Channel 0 in Mode 1 and 3 can be determined as follows:

$$\text{Mode 1, 3 baud rate} = \frac{2^{\text{SMOD}} \times \text{oscillator frequency}}{64 \times (2^{10} - \text{S0REL})}$$

with S0REL = S0RELH.1 – 0, S0RELL.7 – 0

**5.4.2 Serial Channel 1 Baud Rate Generator**

A new baud rate generator for Serial Channel 1 now offers a wider range of selectable baud rates. Especially a baud rate of 1200 baud can be achieved now.

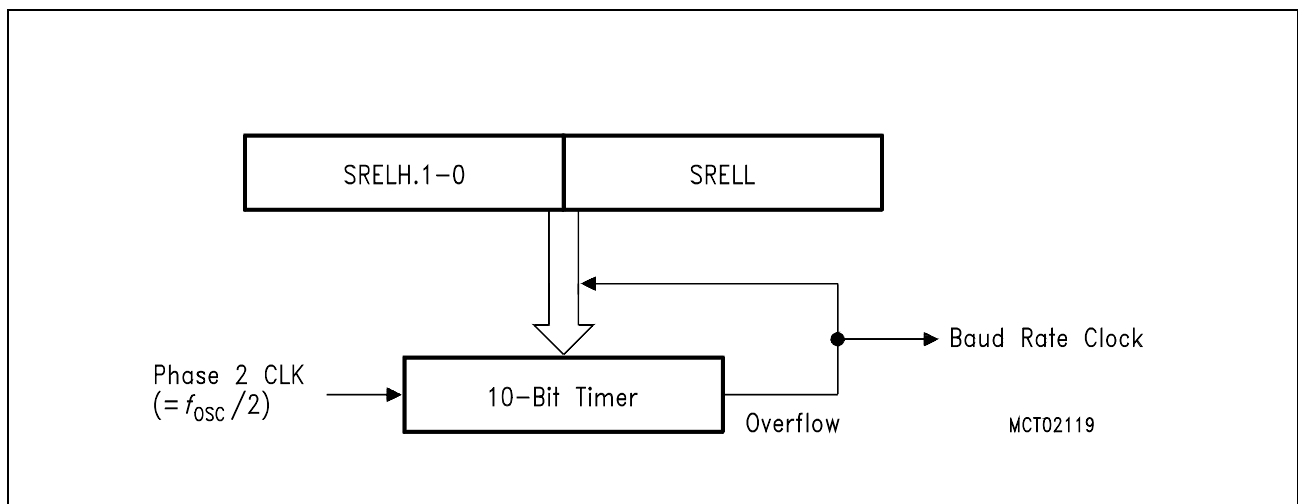
The baud rate generator itself is identical with the one used for Serial Channel 0. It consists of a free running 10-bit timer with  $F_{OSC} / 2$  input frequency. On overflow of this timer there is an automatic reload from the registers S1RELL (address 9D<sub>H</sub>) and S1RELH (address BB<sub>H</sub>). The lower 8 bits of the timer are reloaded from S1RELL, while the upper two bits are reloaded from bit 0 and 1 of register S1RELH. The baud rate timer is reloaded by writing to S1RELL.

The baud rate in mode A and B can be determined by the following formula:

$$\text{Mode A, B baud rate} = \frac{\text{oscillator frequency}}{32 \times (2^{10} - \text{S1REL})}$$

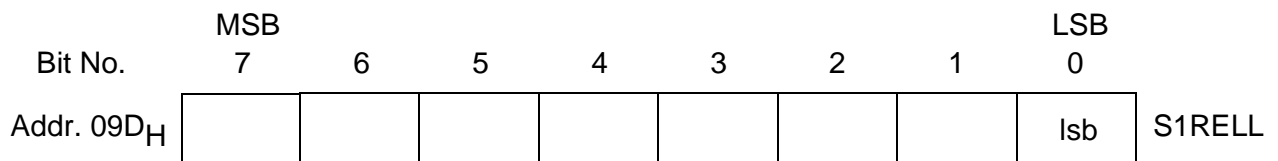
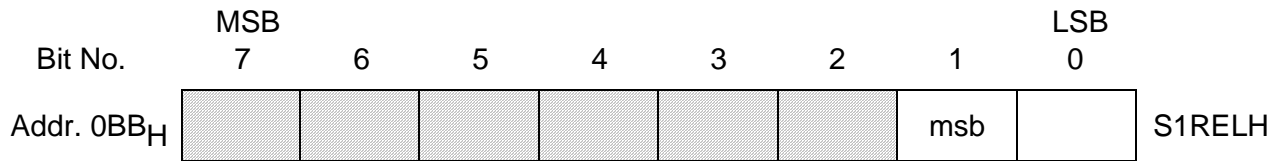
with S1REL = S1RELH.1 – 0, S1RELL.7 – 0

**Figure 5-6** shows a block diagram of the baud rate generator for Serial Interface 1.



**Figure 5-6**  
**Baud Rate Generator for Serial Interface 1**

### Special Function Register SRELH, SRELL



shaded areas are not used for programming the baudrate timer

Bit	Function
S1RELH.0-1	Reload value. Upper two bits of the timer reload value.
S1RELL.0-7	Reload value. Lower 8 bit of timer reload value.

Reset value of S1RELL is 00<sub>H</sub>, S1RELH contains XXXX XXX11B.

### **5.5 Modified Oscillator Watchdog Unit**

The SAB 80C517A has a new oscillator watchdog unit that has an improved functionality with respect to the SAB 80C517's oscillator watchdog.

#### **Use of the Oscillator Watchdog Unit**

The unit serves three functions:

- Monitoring of the on-chip oscillator's function.  
The watchdog supervises the on-chip oscillator's frequency; if it is lower than the frequency of the auxiliary RC oscillator in the watchdog unit, the internal clock is supplied by the RC oscillator and the device is brought into reset; if the failure condition disappears (i.e. the on-chip oscillator has a higher frequency than the RC oscillator), the part executes a final reset phase of appr. 0.5 ms in order to allow the oscillator to stabilize; then the oscillator watchdog reset is released and the part starts program execution again.
- Restart from the Hardware Power Down Mode.  
If the Hardware Power Down Mode is terminated the oscillator watchdog has to control the correct start-up of the on-chip oscillator and to restart the program. The oscillator watchdog function is only part of the complete Hardware Power Down sequence; however, the watchdog works identically to the monitoring function.
- Fast internal reset after power-on.  
In this function the oscillator watchdog unit provides a clock supply for the reset before the on-chip oscillator has started. In this case the oscillator watchdog unit also works identically to the monitoring function.

If the oscillator watchdog unit shall be used it must be enabled (this is done by applying high level to the control pin OWE).

Detailed Description of the Oscillator Watchdog Unit

Figure 5-7 shows the block diagram of the oscillator watchdog unit. It consists of an internal RC oscillator which provides the reference frequency for the comparison with the frequency of the on-chip oscillator. The RC oscillator can be enabled/disabled by the control pin OWE . If it is disabled the complete unit has no function.

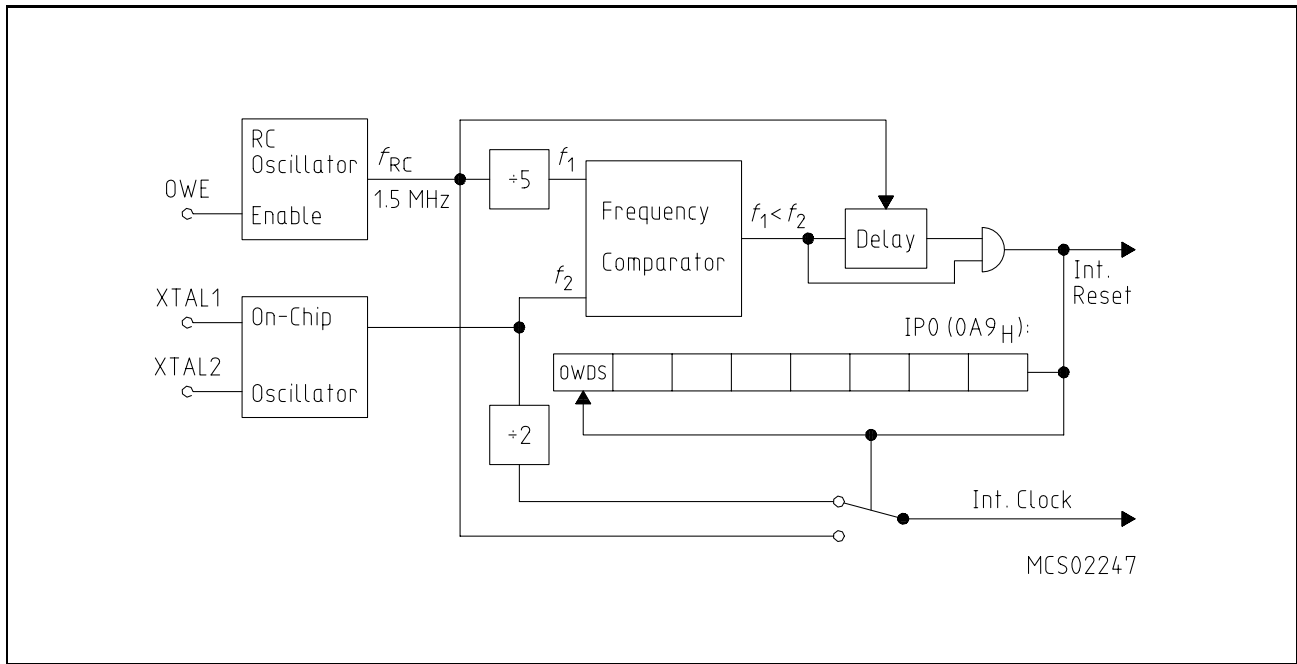


Figure 5-7  
Oscillator Watchdog Unit

Special Function Register IP0 (Address 0A9H)

Bit No.	MSB							LSB	IP0
	7	6	5	4	3	2	1	0	
0A9H	OWDS	WDTs	IP0.5	IP0.4	IP0.3	IP0.2	IP0.1	IP0.0	

These bits are not used in controlling the fail safe mechanisms.

Bit	Function
OWDS	Oscillator watchdog timer status flag. Set by hardware when an oscillator watchdog reset occurred. Can be cleared or set by software.

Reset value of IP0 is 00H.

The frequency coming from the RC oscillator is divided by 5 and compared to the on-chip oscillator's frequency. If the frequency coming from the on-chip oscillator is found lower than the frequency derived from the RC oscillator the watchdog detects a failure condition (the oscillation at the on-chip oscillator could stop because of crystal damage etc.). In this case it switches the input of the internal clock system to the output of the RC oscillator. This means that the part is being clocked even if the on-chip oscillator has stopped or has not yet started. At the same time the watchdog activates the internal reset in order to bring the part in its defined reset state. The reset is performed because clock is available from the RC oscillator. This internal watchdog reset has the same effects as an externally applied reset signal with the following exception: The Watchdog Timer Status flag WDTS (IP0.6) is not reset (the Watchdog Timer however is stopped) and bit OWDS is set. This allows the software to examine error conditions detected by the Watchdog Timer even if meanwhile an oscillator failure occurred.

The oscillator watchdog is able to detect a recovery of the on-chip oscillator after a failure. If the frequency derived from the on-chip oscillator is again higher than the reference the watchdog starts a final reset sequence which takes typ. 1 ms. Within that time the clock is still supplied by the RC oscillator and the part is held in reset. This allows a reliable stabilization of the on chip oscillator. After that, the watchdog toggles the clock supply back to the on-chip oscillator and releases the reset request. If no external reset is applied in this moment the part will start program execution. If an external reset is active, however, the device will keep the reset state until also the external reset request disappears.

Furthermore, the status flag OWDS (IP0.7) is set if the oscillator watchdog was active. The status flag can be evaluated by software to detect that a reset was caused by the oscillator watchdog. The flag OWDS can be set or cleared by software. An external reset request, however, also resets OWDS (and WDTS).



## 6 Interrupt System

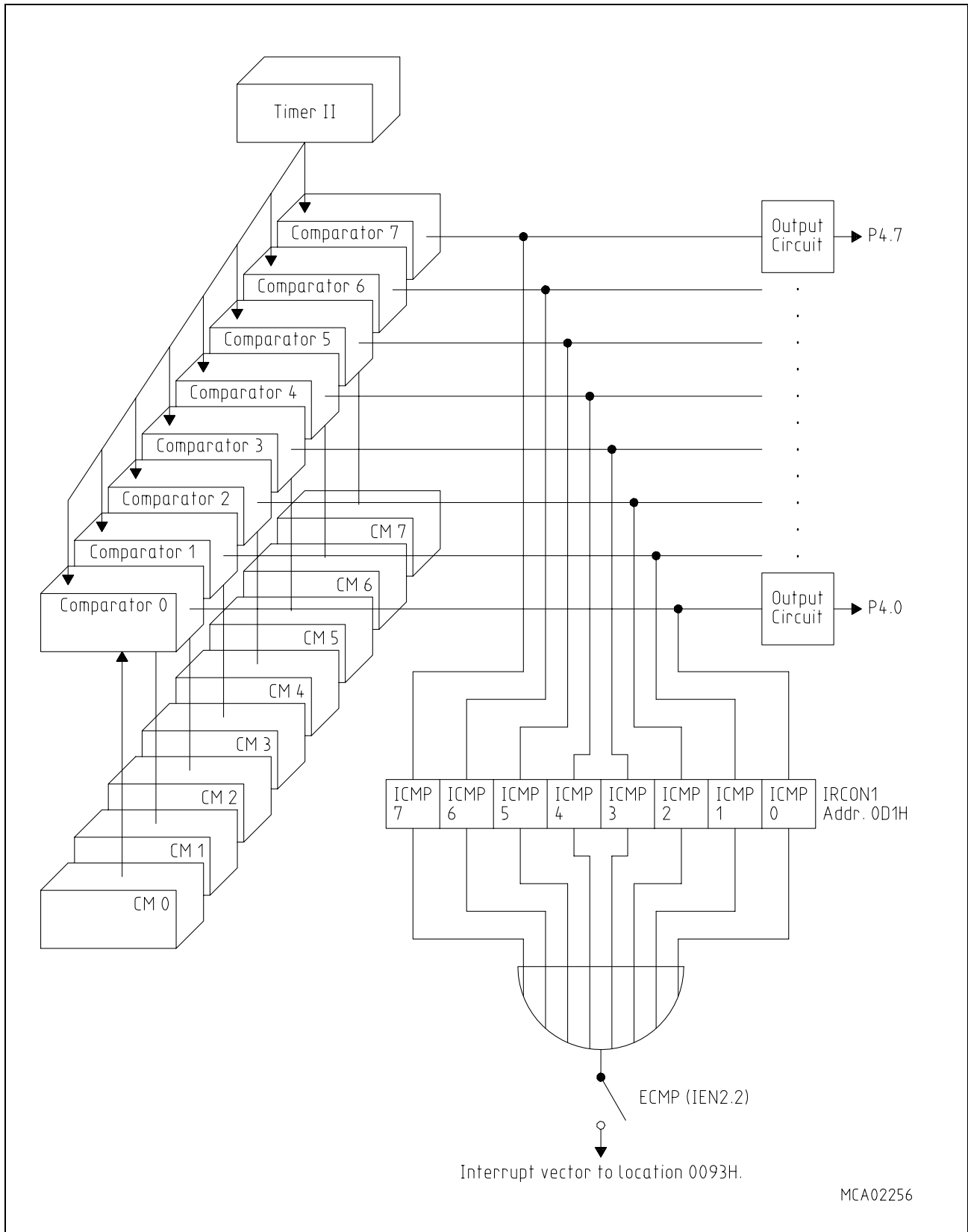
### 6.1 Additional Interrupt for Compare Registers CM0 to CM7

There is an additional interrupt which is vectored to on a compare match in one of the eight comparators of the compare registers CM0 to CM7, when compare mode 1 is selected for the corresponding channel (assigned to Timer 2 by control bit CMSEL.x). For that purpose the SAB 80C517A provides eight interrupt request flags (in SFR IRCON1, address 0D1H) which are ORed to form the interrupt request for that vector, i.e. each of the eight comparators has its own request flag. Thus the service routine may decide which compare match requested the interrupt.

The corresponding request flag is set by every match in the compare channel when the Compare Mode 1 is selected for this channel (assigned to Timer 2). If Compare Mode 0 is selected for a channel (assigned to the Compare Timer), the corresponding interrupt request flag will not be set on a compare match.

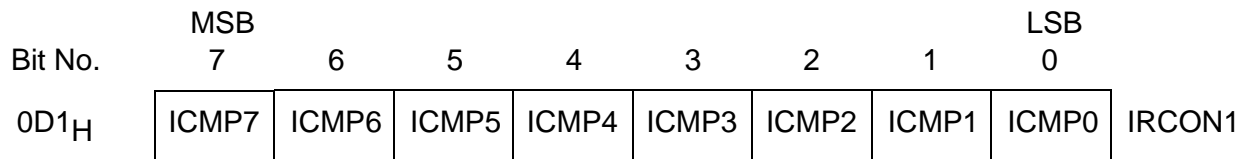
This interrupt is enabled by setting the enable bit ECMP in SFR IEN2. If this bit is set the program vectors to location 0A3H if one of the eight request flags in IRCON 1 is set.

**Figure 6-1** shows a functional block diagram of the new structure concerning the interrupts. The further functions of this compare unit keep full compatibility to the SAB 80C517.



**Figure 6-1**  
**Interrupts of Compare Registers CM0-CM7 Assigned to Timer II**

## Special Function Register IRCON1



Bit	Function
ICMP <sub>x</sub>	Compare x interrupt request flag. Set by hardware when a compare match in compare mode 1 with compare register CM <sub>x</sub> occurred (only, if compare function enabled for CM <sub>x</sub> ). ICMP <sub>x</sub> must be cleared by software (CMSEL.x = 0 and CMEN.x = 1).

The reset value of IRCON1 is 00<sub>H</sub>.

## 6.2 Interrupt Structure

This section summarizes the expanded interrupt structure of the SAB 80C517A which has 3 new interrupt vectors in addition to the 14 vectors of the SAB 80C517. Thus, 17 vectors are available now.

The new interrupt sources are:

### 1. Request Flags

ICMP0 to ICMP7: These eight request flags are set by compare matches in the compare registers CM0-7, if the compare function is enabled and compare mode 1 is selected for the corresponding register SCM0-7.

Interrupt vector: 0093H

Enable Bit: ECMP (IEN2.2)

Priority: Same priority as IE1/IE3, programmed by IP1.2/IP0.2

### 2. Request Flag:

ICS This request flag is set by a compare match in compare register COMSET.

Interrupt Vector: 00A3H

Enable Bit: ECS (IEN2.4)

Priority: Same priority as RI0+TI0/IE5, programmed by IP1.4/IP0.4

### 3. Request Flag:

ICR This request flag is set by a compare match in compare register COMCLR

Interrupt Vector: 00ABH

Enable Bit: ECR (IEN2.5)

Priority: Same priority as TF2+EXF2/IE6, programmed by IP1.5/IP0.5

### 3.1 Priority Level Structure

The following tables show the SFR IEN2, the priority level grouping (**table 6-1**) and the priority within level (**table 6-2**). The principle of the priority level selection is identical to the SAB 80C517, i.e. a pair or triple can be programmed to one of four priority levels.

#### Special Function Register IEN2

	MSB							LSB	
Bit No.	7	6	5	4	3	2	1	0	
09A <sub>H</sub>	-	-	ECR	ECS	ECT	ECMP	-	ES1	IEN2

Bit	Function
ES1	Enable serial interrupt of interface 1. Enables or disables the interrupt of serial interface 1. If ES1 = 0, the interrupt is disabled.
ECMP	Enables interrupt on compare match in compare registers CM0 - CM7. If ECMP = 0, the interrupt is disabled.
ECT	Enable compare timer interrupt. Enables or disables the interrupt at compare timer overflow. If ECT = 0, the interrupt is disabled.
ECS	Enables interrupt on compare match in compare register COMSET. If ECS = 0, the interrupt is disabled.
ECR	Enabled interrupt on compare match in compare register COMCLR. If ECR = 0, the interrupt is disabled.

The reset value of IEN2 is XX00 00X0B.

**Table 6-1, Pairs and triplets of interrupt sources**

External Interrupt 0	Serial Channel 1 Interrupt	A/D Converter Interrupt
Timer 0 Interrupt	–	External Interrupt 2
External Interrupt 1	Match in CM0 - CM7	External Interrupt 3
Timer 1 Interrupt	Compare Timer Overflow	External Interrupt 4
Serial Channel 0 Interrupt	Match in COMSET	External Interrupt 5
Timer 2 Interrupt	Match in COMCLR	External Interrupt 6

**Table 6-2, Priority within Level**

Interrupt Source			Priority
High	→	Low	
IE0	RI1 + TI1	IADC	High
TF0	–	IEX2	
IE1	ICMP0-7	IEX3	↓
TF1	CTF	IEX4	
RI0 + TI0	ICS	IEX5	
TF2 + EXF2	ICR	IEX6	
			Low

### High-Performance 8-Bit CMOS Single-Chip Microcontroller

### SAB 80C517A/83C517A-5

#### Preliminary

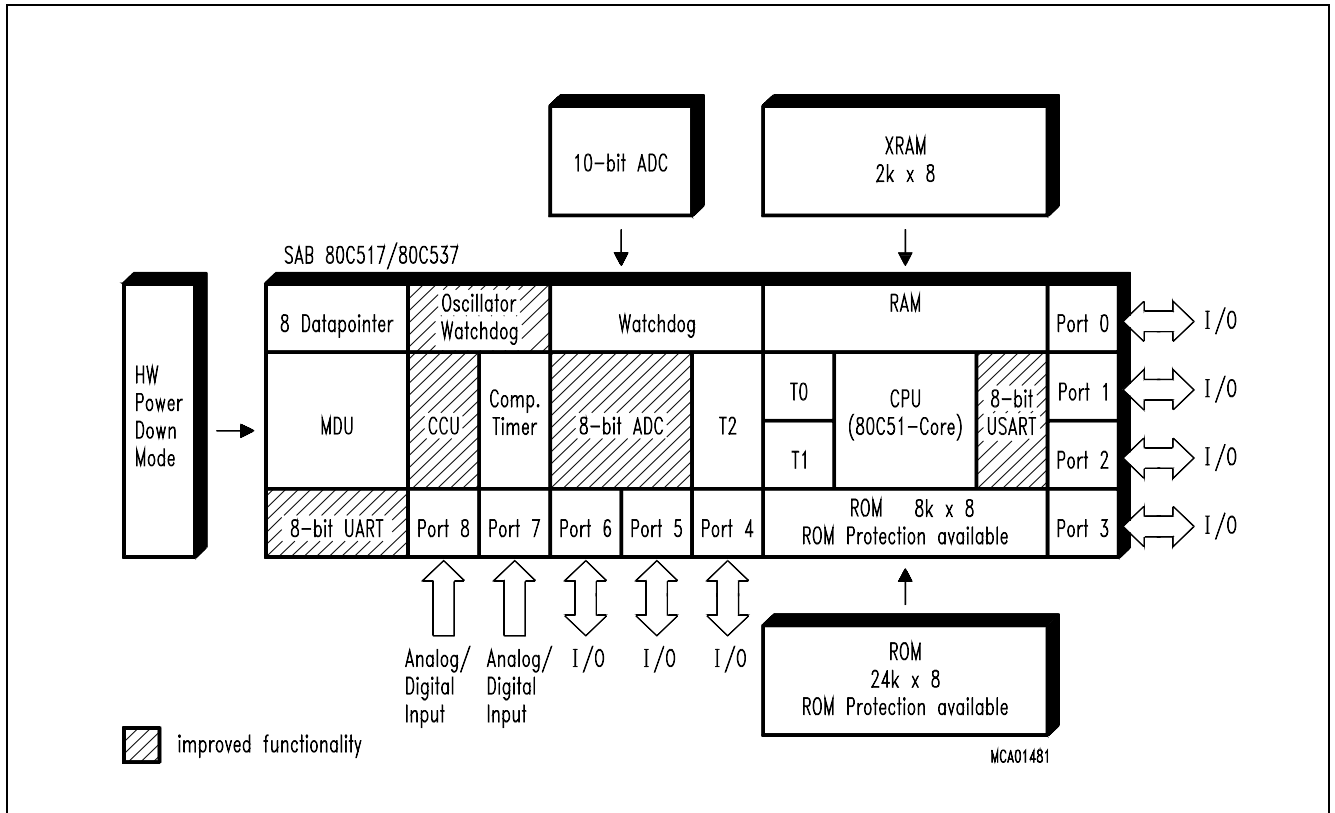
**SAB 83C517A-5**  
**SAB 80C517A**

Microcontroller with factory mask-programmable ROM  
Microcontroller for external ROM

- SAB 80C517A/83C517A-5, up to 18 MHz operation
- 32 K × 8 ROM (SAB 83C517A-5 only, ROM-Protection available)
- 256 × 8 on-chip RAM
- 2 K × 8 on-chip RAM (XRAM)
- Superset of SAB 80C51 architecture:
  - 1 μs instruction cycle time at 12 MHz
  - 666 ns instruction cycle time at 18 MHz
  - 256 directly addressable bits
  - Boolean processor
  - 64 Kbyte external data and program memory addressing
- Four 16-bit timer/counters
- Powerful 16-bit compare/capture unit (CCU) with up to 21 high-speed or PWM output channels and 5 capture inputs
- Versatile "fail-safe" provisions
- Fast 32-bit division, 16-bit multiplication, 32-bit normalize and shift by peripheral MUL/DIV unit (MDU)
- Eight data pointers for external memory addressing
- Seventeen interrupt vectors, four priority levels selectable
- Genuine 10-bit A/D converter with 12 multiplexed inputs
- Two full duplex serial interfaces with programmable Baudrate-Generators
- Fully upward compatible with SAB 80C515, SAB 80C517, SAB 80C515A
- Extended power saving mode
- Fast Power-On Reset
- Nine ports: 56 I/O lines, 12 input lines
- Three temperature ranges available:
  - 0 to 70 °C (T1)
  - 40 to 85°C (T3)
  - 40 to 110°C (T4)
- Plastic packages: P-LCC-84, P-MQFP-100-2

The SAB 80C517A/83C517A-5 is a high-end member of the Siemens SAB 8051 family of microcontrollers. It is designed in Siemens ACMOS technology and based on SAB 8051 architecture. ACMOS is a technology which combines high-speed and density characteristics with low-power consumption or dissipation.

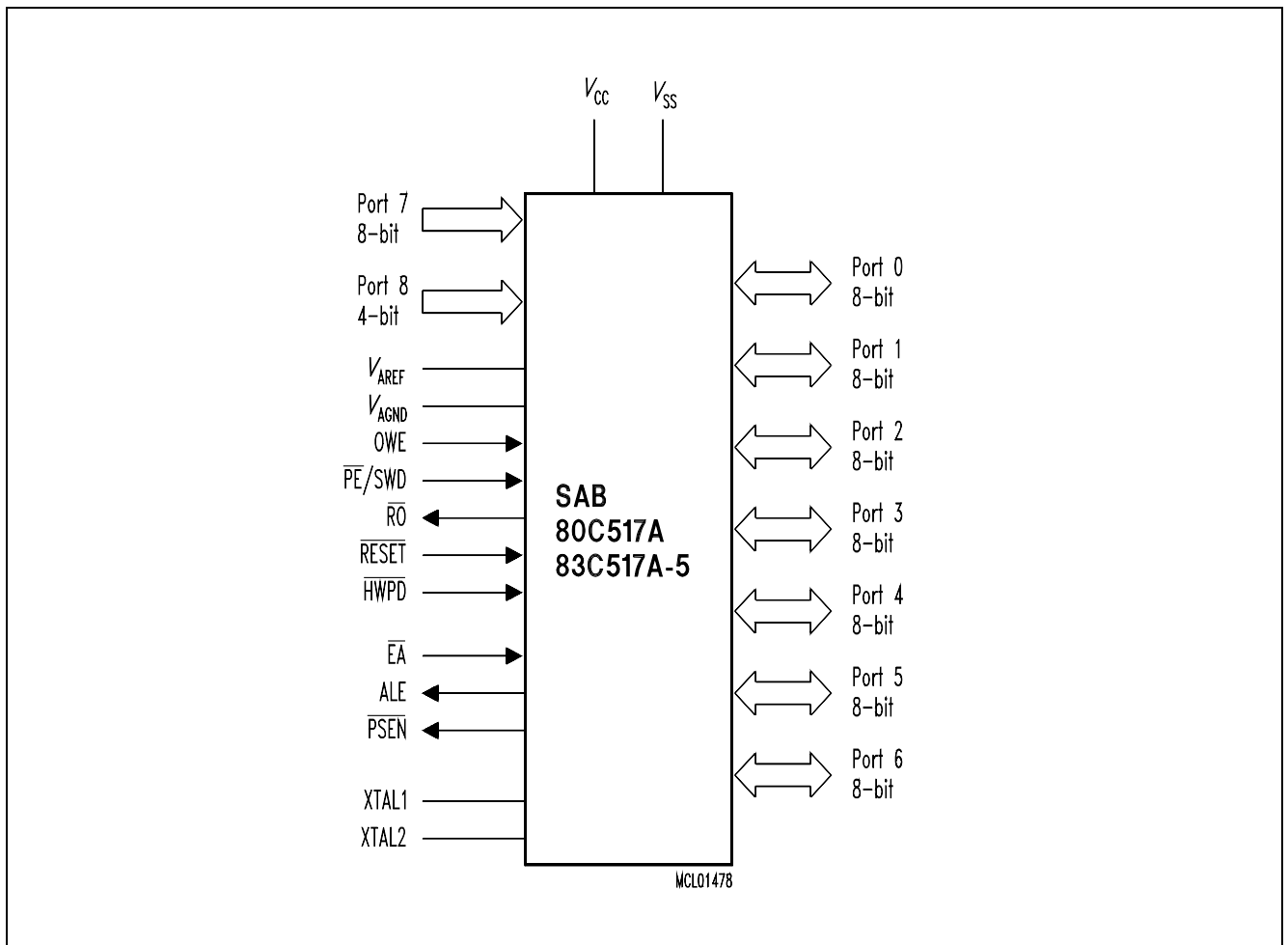
While maintaining all the SAB 80C517 features and operating characteristics the SAB 80C517A is expanded in its "fail-safe" characteristics and timer capabilities. The SAB 80C517A is identical with the SAB 83C517A-5 except that it lacks the on-chip program memory. The SAB 80C517A/83C517A-5 is supplied in a 84-pin plastic leaded chip carrier package (P-LCC-84) and in a 100-pin plastic quad flat package (P-MQFP-100-2).



**Ordering Information**

Type	Ordering code	Package	Description 8-bit CMOS microcontroller
SAB 80C517A-N18	Q67120-C583	P-LCC-84	for external memory, 18 MHz
SAB 80C517A-M18	TBD	P-MRFP-100	
SAB 83C517A-5N18	Q67120-C582	P-LCC-84	with mask-programmable ROM, 18 MHz
SAB 80C517A-N18-T3	Q67120-C769	P-LCC-84	for external memory, 18 MHz ext. temperature – 40 to 85 °C
SAB 83C517A-5N18-T3	Q67120-C771	P-LCC-84	with mask-programmable ROM, 18 MHz ext. temperature – 40 to 85 °C
SAB 83C517A-N18-T4	TBD	P-LCC-84	for external memory, 18 MHz ext. temperature -40 to +110°C
SAB 83C517A-5N18-T4	TBD	P-LCC-84	with mask-programmable ROM, 18 MHz ext. temperature -40 to +110°C

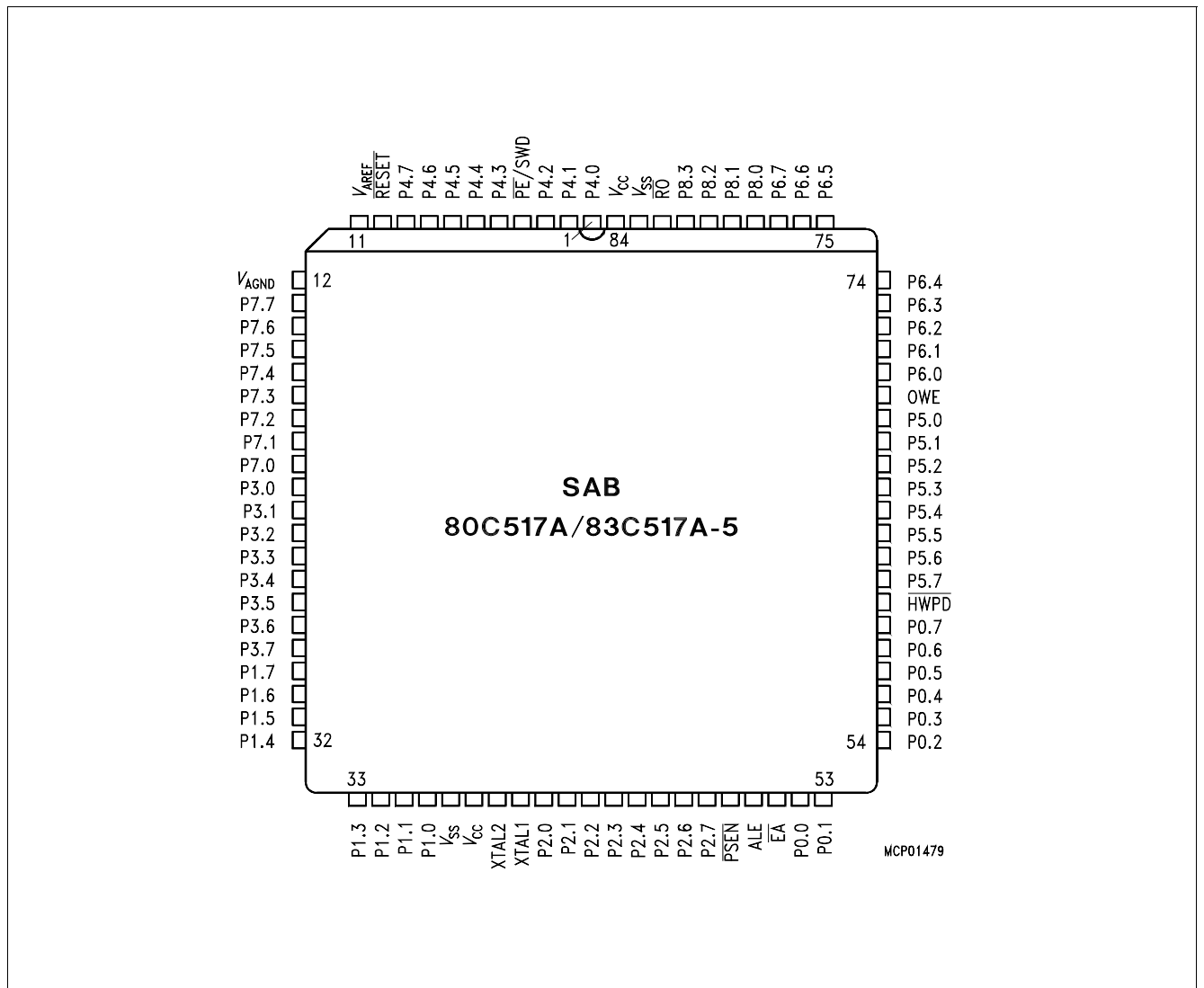




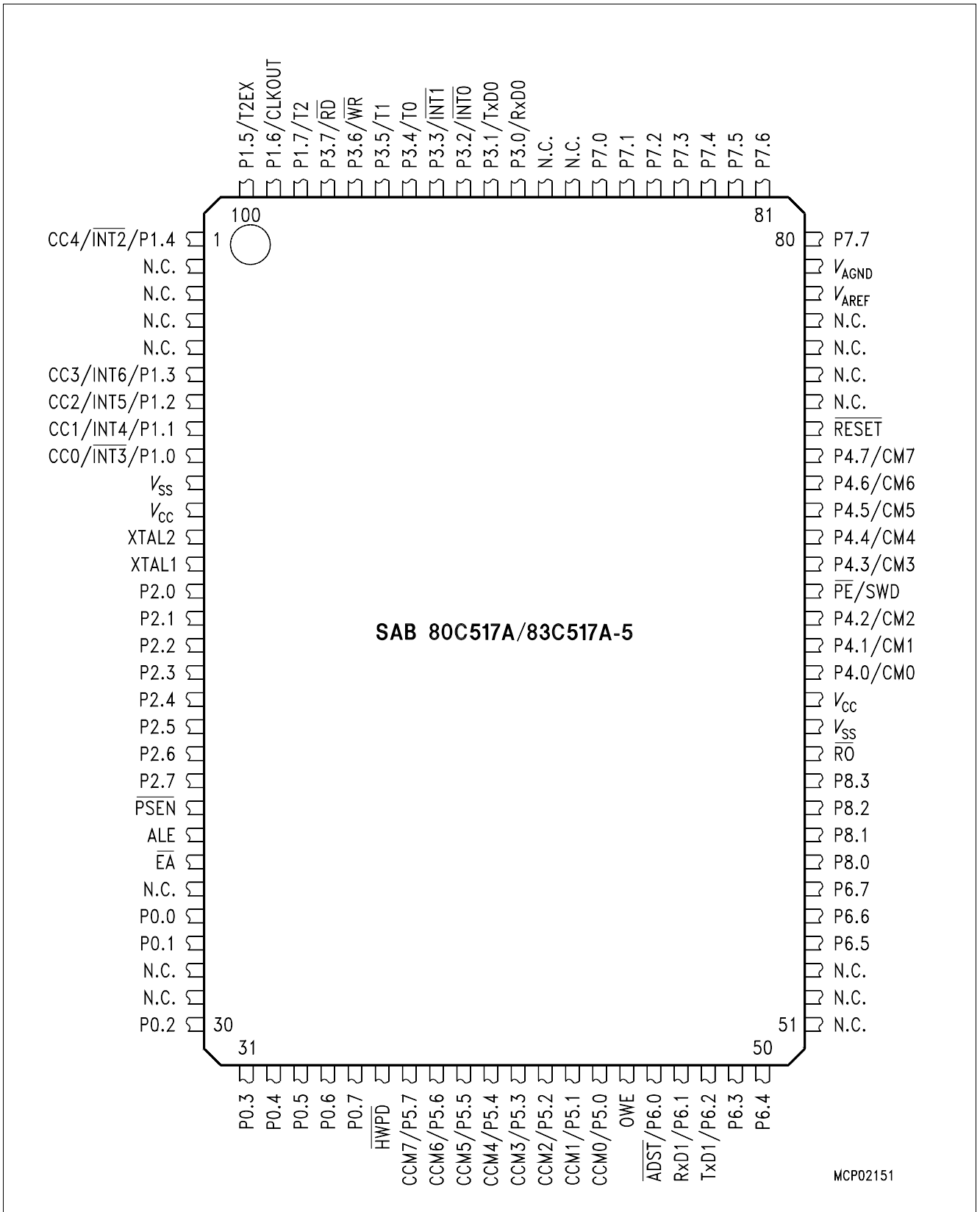
Logic Symbol

The pin functions of the SAB 80C517A are identical with those of the SAB 80C517/80C537 with one exception:

Typ	SAB 80C517A	SAB 80C517/80C537
P-LCC-84, Pin 60	HWPDP	N.C.
P-MQFP-100-2, Pin 36		



## Pin Configuration (P-LCC-84)



MCP02151

**Pin Configuration**  
(P-MQFP-100-2)

## Pin Definitions and Functions

Symbol	Pin Number		I/O *)	Function
	P-LCC-84	P-MQFP-100-2		
P4.0 – P4.7	1– 3, 5 – 9	64 - 66, 68 - 72	I/O	<p><b>Port 4</b> is a bidirectional I/O port with internal pull-up resistors. Port 4 pins that have 1s written to them are pulled high by the internal pull-up resistors, and in that state can be used as inputs. As inputs, port 4 pins being externally pulled low will source current (<math>I_{IL}</math>, in the DC characteristics) because of the internal pull-up resistors.</p> <p>This port also serves alternate compare functions. The secondary functions are assigned to the pins of port 4 as follows:</p> <ul style="list-style-type: none"> <li>– CM0 (P4.0): Compare Channel 0</li> <li>– CM1 (P4.1): Compare Channel 1</li> <li>– CM2 (P4.2): Compare Channel 2</li> <li>– CM3 (P4.3): Compare Channel 3</li> <li>– CM4 (P4.4): Compare Channel 4</li> <li>– CM5 (P4.5): Compare Channel 5</li> <li>– CM6 (P4.6): Compare Channel 6</li> <li>– CM7 (P4.7): Compare Channel 7</li> </ul>
$\overline{PE}/SWD$	4	67	I	<p><b>Power saving modes <math>\overline{enable}</math> Start Watchdog Timer</b></p> <p>A low level on this pin allows the software to enter the power down, idle and slow down mode. In case the low level is also seen during reset, the watchdog timer function is off on default.</p> <p>Use of the software controlled power saving modes is blocked, when this pin is held on high level. A high level during reset performs an automatic start of the watchdog timer immediately after reset. When left unconnected this pin is pulled high by a weak internal pull-up resistor.</p>

\* I = Input  
O = Output

## Pin Definitions and Functions (cont'd)

Symbol	Pin Number		I/O *)	Function
	P-LCC-84	P-MQFP-100-2		
RESET	10	73	I	<b>RESET</b> A low level on this pin for the duration of one machine cycle while the oscillator is running resets the SAB 80C517A. A small internal pull-up resistor permits power-on reset using only a capacitor connected to $V_{SS}$ .
$V_{AREF}$	11	78		<b>Reference voltage</b> for the A/D converter.
$V_{AGND}$	12	79		<b>Reference ground</b> for the A/D converter.
P7.7 -P7.0	13 - 20	80 - 87	I	<b>Port 7</b> is an 8-bit unidirectional input port. Port pins can be used for digital input, if voltage levels meet the specified input high/low voltages, and for the lower 8-bit of the multiplexed analog inputs of the A/D converter, simultaneously.

\* I = Input  
O = Output

## Pin Definitions and Functions (cont'd)

Symbol	Pin Number		I/O *)	Function
	P-LCC-84	P-MQFP-100-2		
P3.0 - P3.7	21 - 28	90 - 97	I/O	<p><b>Port 3</b> is a bidirectional I/O port with internal pull-up resistors. Port 3 pins that have 1 s written to them are pulled high by the internal pull-up resistors, and in that state can be used as inputs. As inputs, port 3 pins being externally pulled low will source current (<math>I_{IL}</math>, in the DC characteristics) because of the internal pull-up resistors. Port 3 also contains the interrupt, timer, serial port 0 and external memory strobe pins that are used by various options. The output latch corresponding to a secondary function must be programmed to a one (1) for that function to operate.</p> <p>The secondary functions are assigned to the pins of port 3, as follows:</p> <ul style="list-style-type: none"> <li>– R × D0 (P3.0): receiver data input (asynchronous) or data input/output (synchronous) of serial interface</li> <li>– T × D0 (P3.1): transmitter data output (asynchronous) or clock output (synchronous) of serial interface 0</li> <li>– <math>\overline{INT0}</math> (P3.2): <math>\overline{\text{interrupt 0 input/timer 0 gate control}}</math></li> <li>– <math>\overline{INT1}</math> (P3.3): <math>\overline{\text{interrupt 1 input/timer 1 gate control}}</math></li> <li>– T0 (P3.4): counter 0 input</li> <li>– T1 (P3.5): counter 1 input</li> <li>– <math>\overline{WR}</math> (P3.6): the write control signal latches the data byte from port 0 into the external data memory</li> <li>– <math>\overline{RD}</math> (P3.7): the read control signal enables the external data memory to port 0</li> </ul>

\* I = Input  
O = Output

## Pin Definitions and Functions (cont'd)

Symbol	Pin Number		I/O *)	Function
	P-LCC-84	P-MQFP-100-2		
P1.7 - P1.0	29 - 36	98 - 100, 1, 6 - 9	I/O	<p><b>Port 1</b> is a bidirectional I/O port with internal pull-up resistors. Port 1 pins that have 1 s written to them are pulled high by the internal pull-up resistors, and in that state can be used as inputs. As inputs, port 1 pins being externally pulled low will source current (<math>I_{IL}</math>, in the DC characteristics) because of the internal pull-up resistors. It is used for the low order address byte during program verification. It also contains the interrupt, timer, clock, capture and compare pins that are used by various options. The output latch must be programmed to a one (1) for that function to operate (except when used for the compare functions). The secondary functions are assigned to the port 1 pins as follows:</p> <ul style="list-style-type: none"> <li>– <math>\overline{\text{INT3}}/\text{CC0}</math> (P1.0): <math>\overline{\text{interrupt 3 input}}/\text{compare 0 output /capture 0 input}</math></li> <li>– <math>\text{INT4}/\text{CC1}</math> (P1.1): <math>\text{interrupt 4 input / compare 1 output /capture 1 input}</math></li> <li>– <math>\text{INT5}/\text{CC2}</math> (P1.2): <math>\text{interrupt 5 input / compare 2 output /capture 2 input}</math></li> <li>– <math>\text{INT6}/\text{CC3}</math> (P1.3): <math>\text{interrupt 6 input / compare 3 output /capture 3 input}</math></li> <li>– <math>\overline{\text{INT2}}/\text{CC4}</math> (P1.4): <math>\overline{\text{interrupt 2 input}}/\text{compare 4 output /capture 4 input}</math></li> <li>– T2EX (P1.5): <math>\text{timer 2 external reload trigger input}</math></li> <li>– CLKOUT (P1.6): <math>\text{system clock output}</math></li> <li>– T2 (P1.7): <math>\text{counter 2 input}</math></li> </ul>

\* I = Input  
O = Output

### Pin Definitions and Functions (cont'd)

Symbol	Pin Number		I/O *)	Function
	P-LCC-84	P-MQFP-100-2		
XTAL2	39	12	–	<b>XTAL2</b> Input to the inverting oscillator amplifier and input to the internal clock generator circuits.
XTAL1	40	13	–	<b>XTAL1</b> Output of the inverting oscillator amplifier. To drive the device from an external clock source, XTAL2 should be driven, while XTAL1 is left unconnected. There are no requirements on the duty cycle of the external clock signal, since the input to the internal clocking circuitry is divided down by a divide-by-two flip-flop. Minimum and maximum high and low times as well as rise/fall times specified in the AC characteristics must be observed.
P2.0 - P2.7	41 - 48	14 - 21	I/O	<b>Port 2</b> is a bidirectional I/O port with internal pull-up resistors. Port 2 pins that have 1 s written to them are pulled high by the internal pull-up resistors, and in that state can be used as in-puts. As inputs, port 2 pins being externally pulled low will source current ( $I_{IL}$ , in the DC characteristics) because of the internal pull-up resistors. Port 2 emits the high-order address byte during fetches from external program memory and during accesses to external data memory that use 16-bit addresses (MOVX @DPTR). In this application it uses strong internal pull-up resistors when issuing1 s. During accesses to external data memory that use 8-bit addresses (MOVX @Ri), port 2 issues the contents of the P2 special function register.

\* I = Input  
O = Output



## Pin Definitions and Functions (cont'd)

Symbol	Pin Number		I/O *)	Function
	P-LCC-84	P-MQFP-100-2		
PSEN	49	22	O	The <b>Program Store Enable</b> output is a control signal that enables the external program memory to the bus during external fetch operations. It is activated every six oscillator periods except during external data memory accesses. Remains high during internal program execution.
ALE	50	23	O	The <b>Address Latch Enable</b> output is used for latching the address into external memory during normal operation. It is activated every six oscillator periods except during an external data memory access
EA	51	24	I	<b>External Access Enable</b> When held at high level, instructions are fetched from the internal ROM (SAB 83C517A-5 only) when the PC is less than 8000H. When held at low level, the SAB 80C517A fetches all instructions from external program memory. For the SAB 80C517A this pin must be tied low
P0.0 - P0.7	52 - 59	26 - 27, 30 - 35	I/O	<b>Port 0</b> is an 8-bit open-drain bidirectional I/O port. Port 0 pins that have 1 s written to them float, and in that state can be used as high-impedance inputs. Port 0 is also the multiplexed low-order address and data bus during accesses to external program or data memory. In this application it uses strong internal pull-up resistors when issuing 1 s. Port 0 also out-puts the code bytes during program verification in the SAB 83C517A if ROM-Protection was not enabled. External pull-up resistors are required during program verification.

\* I = Input  
O = Output

## Pin Definitions and Functions (cont'd)

Symbol	Pin Number		I/O *)	Function
	P-LCC-84	P-MQFP-100-2		
HWP $\bar{D}$	60	36	I	<p><b>Hardware Power Down</b></p> <p>A low level on this pin for the duration of one machine cycle while the oscillator is running resets the SAB 80C517A. A low level for a longer period will force the part to Power Down Mode with the pins floating. (see table 7)</p>
P5.7 - P5.0	61 - 68	37 - 44	I/O	<p><b>Port 5</b></p> <p>is a bidirectional I/O port with internal pull-up resistors. Port 5 pins that have 1 s written to them are pulled high by the internal pull-up resistors, and in that state can be used as inputs. As inputs, port 5 pins being externally pulled low will source current (<math>I_{IL}</math>, in the DC characteristics) because of the internal pull-up resistors. This port also serves the alternate function "Concurrent Compare" and "Set/Reset Compare". The secondary functions are assigned to the port 5 pins as follows:</p> <ul style="list-style-type: none"> <li>– CCM0 to CCM7 (P5.0 to P5.7): concurrent compare or Set/Reset</li> </ul>
OWE	69	45	I/O	<p><b>Oscillator Watchdog Enable</b></p> <p>A high level on this pin enables the oscillator watchdog. When left unconnected this pin is pulled high by a weak internal pull-up resistor. When held at low level the oscillator watchdog function is off.</p>

\* I = Input  
O = Output

## Pin Definitions and Functions (cont'd)

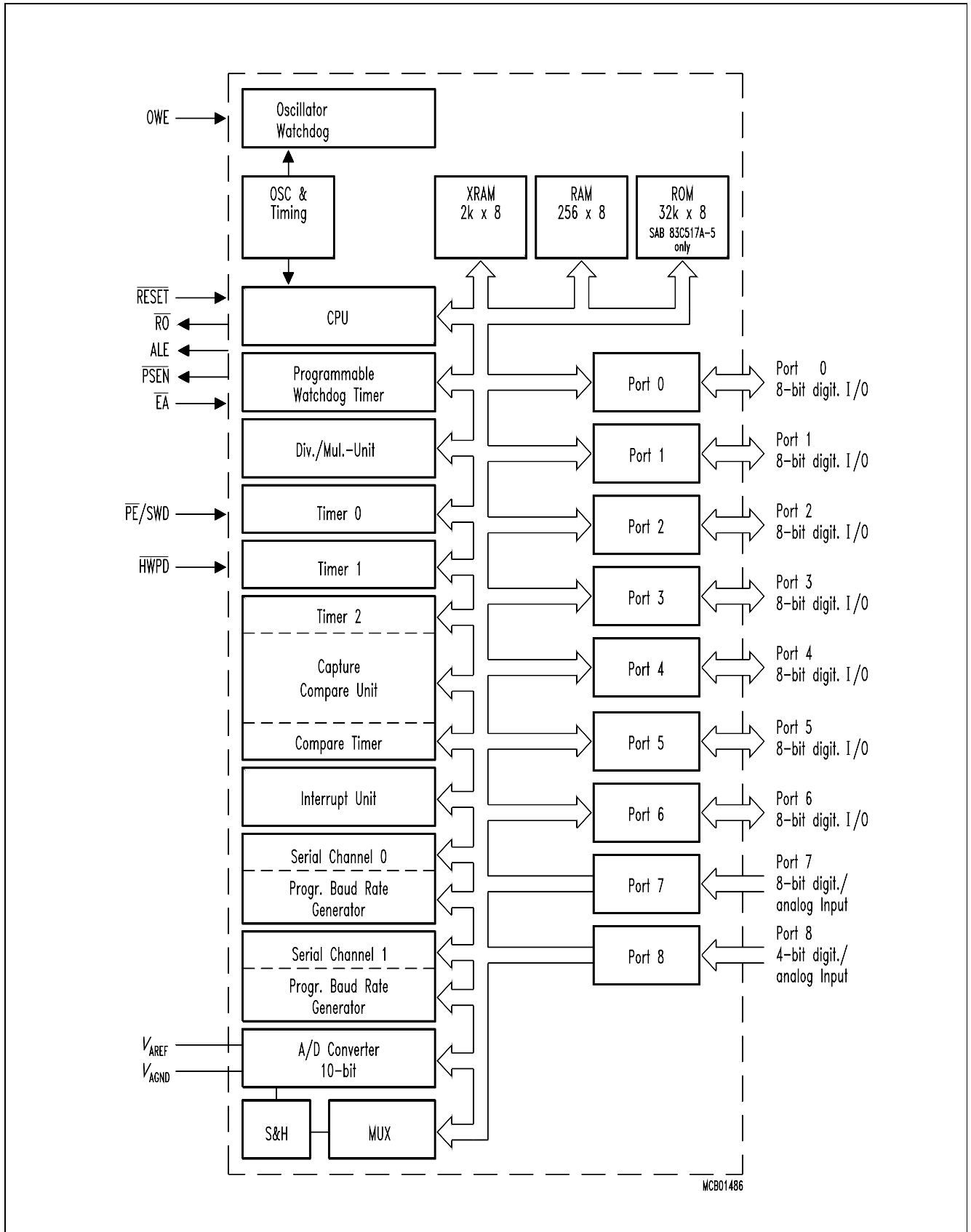
Symbol	Pin Number		I/O *)	Function
	P-LCC-84	P-MQFP-100-2		
P6.0 - P6.7	70 - 77	46 - 50, 54 - 56	I/O	<p><b>Port 6</b> is a bidirectional I/O port with internal pull-up resistors. Port 6 pins that have 1 s written to them are pulled high by the internal pull-up resistors, and in that state can be used as inputs. As inputs, port 6 pins being externally pulled low will source current (<math>I_{IL}</math>, in the DC characteristics) because of the internal pull-up resistors. Port 6 also contains the external A/D converter control pin and the transmit and receive pins for serial channel 1. The output latch corresponding to a secondary function must be programmed to a one (1) for that function to operate. The secondary functions are assigned to the pins of port 6, as follows:</p> <ul style="list-style-type: none"> <li>– <math>\overline{ADST}</math> (P6.0): external A/D converter start pin</li> <li>– <math>R \times D1</math> (P6.1): receiver data input of serial interface 1</li> <li>– <math>T \times D1</math> (P6.2): transmitter data output of serial interface 1</li> </ul>
P8.0 - P8.3	78 - 81	57 - 60	I	<p><b>Port 8</b> is a 4-bit unidirectional input port. Port pins can be used for digital input, if voltage levels meet the specified input high/low voltages, and for the higher 4-bit of the multiplexed analog inputs of the A/D converter, simultaneously</p>

\* I = Input  
O = Output

### Pin Definitions and Functions (cont'd)

Symbol	Pin Number		I/O *)	Function
	P-LCC-84	P-MQFP-100-2		
$\overline{R\bar{O}}$	82	61	O	<b>Reset Output</b> This pin outputs the internally synchronized reset request signal. This signal may be generated by an external hardware reset, a watchdog timer reset or an oscillator watch-dog reset. The reset output is active low.
$V_{SS}$	37, 83	10, 62	–	<b>Circuit ground potential</b>
$V_{CC}$	38, 84	11, 63	–	<b>Supply Terminal</b> for all operating modes
N.C.	–	2 - 5, 25, 28 - 29, 51 - 53, 74 - 77, 88 - 89	–	Not connected

\* I = Input  
O = Output



**Figure 1**  
**Block Diagram**

**Functional Description**

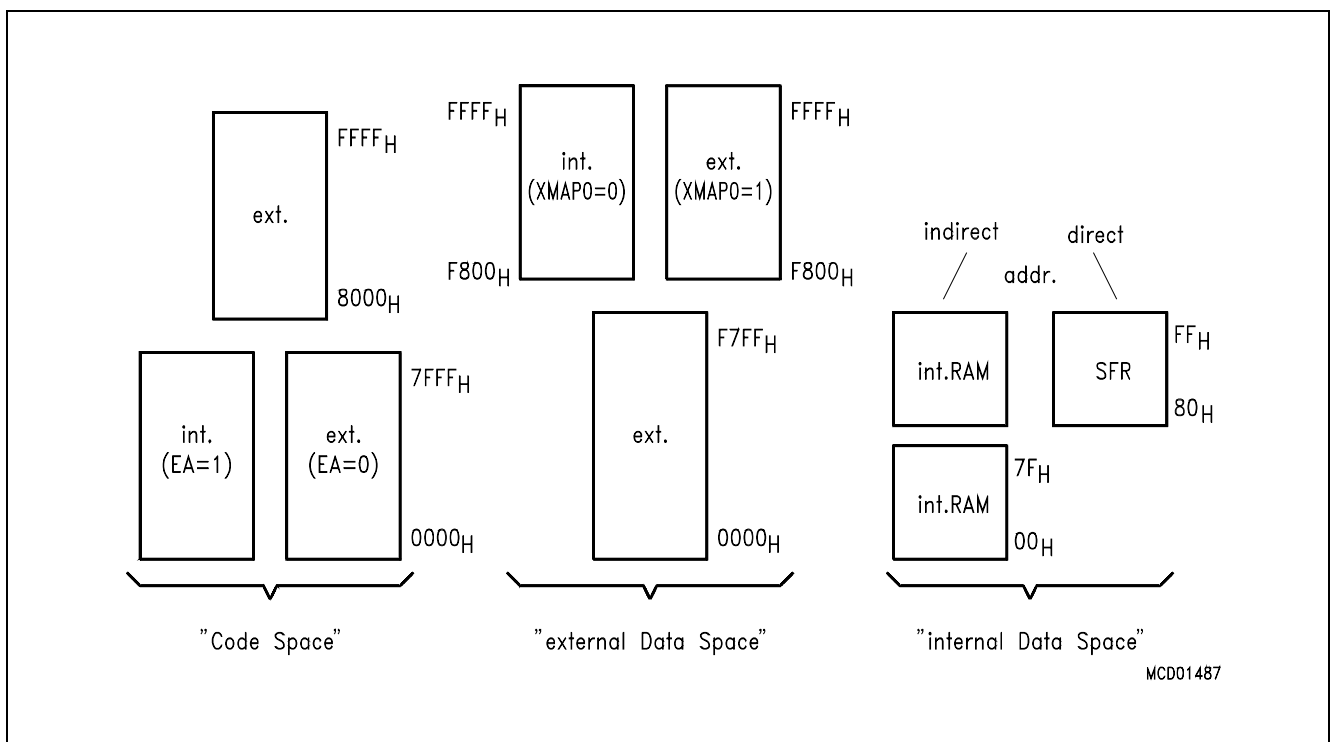
The SAB 80C517A is based on 8051 architecture. It is a fully compatible member of the Siemens SAB 8051/80C51 microcontroller family being an significantly enhanced SAB 80C517. The SAB 80C517A is therefore compatible with code written for the SAB 80C517.

Having an 8-bit CPU with extensive facilities for bit-handling and binary BCD arithmetics the SAB 80C517A is optimized for control applications. With a 18 MHz crystal, 58 % of the instructions are executed in 666.67 ns.

Being designed to close the performance gap to the 16-bit microcontroller world, the SAB 80C517A's CPU is supported by a powerful 32-/16-bit arithmetic unit and a more flexible addressing of external memory by eight 16-bit datapointers.

**Memory Organisation**

According to the SAB 8051 architecture, the SAB 80C517A has separate address spaces for program and data memory. Figure 2 illustrates the mapping of address spaces.



**Figure 2**  
**Memory Map**

### Program Memory ('Code Space')

The SAB 83C517A-5 has 32 Kbyte of on-chip ROM, while the SAB 80C517A has no internal ROM. The program memory can externally be expanded up to 64 Kbyte. Pin  $\overline{EA}$  controls whether program fetches below address 8000H are done from internal or external memory.

As a new feature the SAB 83C517A-5 offers the possibility of protecting the internal ROM against unauthorized access. This protection is implemented in the ROM-Mask. Therefore, the decision ROM-Protection 'yes' or 'no' has to be made when delivering the ROM-Code. Once enabled, there is no way of disabling the ROM-Protection.

Effect: The access to internal ROM done by an externally fetched MOVC instruction is disabled. Nevertheless, an access from internal ROM to external ROM is possible.

To verify the read protected ROM-Code a special ROM-Verify-Mode is implemented. This mode also can be used to verify unprotected internal ROM.

ROM -Protection	ROM-Verification Mode (see 'AC Characteristics')	Restrictions
no	ROM-Verification Mode 1 (standard 8051 Verification Mode) ROM-Verification Mode 2	–
yes	ROM-Verification Mode 2	– standard 8051 Verification Mode is disabled  – externally applied MOVC accessing internal ROM is disabled

### Data Memory ('Code Space')

The data memory space consists of an internal and an external memory space. The SAB 80C517A contains another 2 Kbyte on On-Chip RAM above the 256-bytes internal RAM of the base type SAB 80C517. This RAM is called XRAM in this document.

### External Data Memory

Up to 64 Kbyte external data memory can be addressed by instructions that use 8-bit or 16-bit indirect addressing. For 8-bit addressing MOVX instructions in combination with registers R0 and R1 can be used. A 16-bit external memory addressing is supported by eight 16-bit datapointers. Registers XPAGE and SYSCON are controlling whether data fetches at addresses  $F800_H$  to  $FFFF_H$  are done from internal XRAM or from external data memory.

### Internal Data Memory

The internal data memory is divided into four physically distinct blocks:

- the lower 128 bytes of RAM including four banks containing eight registers each
- the upper 128 byte of RAM
- the 128 byte special function register area.
- a  $2\text{ K} \times 8$  area which is accessed like external RAM (MOVX-instructions), implemented on chip at the address range from  $F800_H$  to  $FFFF_H$ . Special Function Register SYSCON controls whether data is read or written to XRAM or external RAM.

A mapping of the internal data memory is also shown in figure 2. The overlapping address spaces are accessed by different addressing modes (see User's Manual SAB 80C517). The stack can be located anywhere in the internal data memory.

### Architecture for the XRAM

The contents of the XRAM is not affected by a reset or HW Power Down. After power-up the contents is undefined, while it remains unchanged during and after a reset or HW Power Down if the power supply is not turned off.

The additional On-Chip RAM is logically located in the "external data memory" range at the upper end of the 64 Kbyte address range ( $F800_H$ - $FFFF_H$ ). It is possible to enable and disable (only by reset) the XRAM. If it is disabled the device shows the same behaviour as the parts without XRAM, i.e. all MOVX accesses use the external bus to physically external data memory.



### Accesses to XRAM

Because the XRAM is used in the same way as external data memory the same instruction types must be used for accessing the XRAM.

**Note:** *If a reset occurs during a write operation to XRAM, the effect on XRAM depends on the cycle which the reset is detected at (MOVX is a 2-cycle instruction):*

*Reset detection at cycle 1: The new value will not be written to XRAM. The old value is not affected.*

*Reset detection at cycle 2: The old value in XRAM is overwritten by the new value.*

### Accesses to XRAM using the DPTR

There are a Read and a Write instruction from and to XRAM which use one of the 16-bit DPTR for indirect addressing. The instructions are:

MOVX A, @DPTR (Read)

MOVX @DPTR, A (Write)

Normally the use of these instructions would use a physically external memory. However, in the SAB 80C517A the XRAM is accessed if it is enabled and if the DPTR points to the XRAM address space ( $DPTR \geq F800_H$ ).

### Accesses to XRAM using the Registers R0/R1

The 8051 architecture provides also instructions for accesses to external data memory range which use only an 8-bit address (indirect addressing with registers R0 or R1). The instructions are:

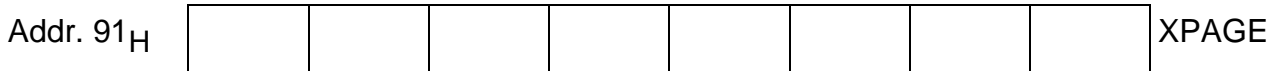
MOVX A, @Ri (Read)

MOVX @Ri, A (Write)

In application systems, either a real 8-bit bus (with 8-bit address) is used or Port 2 serves as page register which selects pages of 256-byte. However, the distinction, whether Port 2 is used as general purpose I/O or as "page address" is made by the external system design. From the device's point of view it cannot be decided whether the Port 2 data is used externally as address or as I/O data!

Hence, a special page register is implemented into the SAB 80C517A to provide the possibility of accessing the XRAM also with the MOVX @Ri instructions, i.e. XPAGE serves the same function for the XRAM as Port 2 for external data memory.

## Special Function Register XPAGE



The reset value of XPAGE is 00<sub>H</sub>.

XPAGE can be set and read by software.

The register XPAGE provides the upper address byte for accesses to XRAM with MOVX @Ri instructions. If the address formed from XPAGE and Ri is less than the XRAM address range, then an external access is performed. For the SAB 80C517A the contents of XPAGE must be greater or equal than F8<sub>H</sub> in order to use the XRAM. Of course, the XRAM must be enabled if it shall be used with MOVX @Ri instructions.

Thus, the register XPAGE is used for addressing of the XRAM; additionally its contents are used for generating the internal XRAM select. If the contents of XPAGE is less than the XRAM address range then an external bus access is performed where the upper address byte is provided by P2 and not by XPAGE!

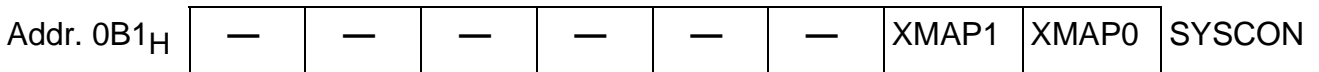
Therefore, the software has to distinguish two cases, if the MOVX @Ri instructions with paging shall be used:

- a) Access to XRAM:                      The upper address byte must be written to XPAGE or P2; both writes selects the XRAM address range.
- b) Access to external memory:      The upper address byte must be written to P2; XPAGE will be loaded with the same address in order to deselect the XRAM.

**Control of XRAM in the SAB 80C517A**

There are two control bits in register SYSCON which control the use and the bus operation during accesses to the additional On-Chip RAM (XRAM).

**Special Function Register SYSCON**



Bit	Function
XMAP0	Global enable/disable bit for XRAM memory. XMAP0 = 0: The access to XRAM (= On-Chip XDATA memory) is enabled. XMAP0 = 1: The access to XRAM is disabled. All MOVX accesses are performed by the external bus (reset state).
XMAP1	Control bit for $\overline{RD}/\overline{WR}$ signals during accesses to XRAM; this bit has no effect if XRAM is disabled (XMAP0 = 1) or if addresses exceeding the XRAM address range are used for MOVX accesses. XMAP1 = 0: The signals $\overline{RD}$ and $\overline{WR}$ are not activated during accesses to XRAM. XMAP1 = 1: The signals $\overline{RD}$ and $\overline{WR}$ are activated during accesses to XRAM.

Reset value of SYSCON is xxxx xx01B.

The control bit XMAP0 is a global enable/disable bit for the additional On-Chip RAM (XRAM). If this bit is set, the XRAM is disabled, all MOVX accesses use external memory via the external bus. In this case the SAB 80C517A does not use the additional On-Chip RAM and is compatible with the types without XRAM.

XMAP0 is hardware protected by an unsymmetric latch. An unintentional disabling of XRAM could be dangerous since indeterminate values would be read from external bus. To avoid this the XMAP-bit is forced to '1' only by reset. Additionally, during reset an internal capacitor is loaded. So after reset state XRAM is disabled. Because of the load time of the capacitor XMAP0-bit once written to '0' (that is, discharging capacitor) cannot be set to '1' again by software. On the other hand any distortion (software hang up, noise, ...) is not able to load this capacitor, too. That is, the stable status is XRAM enabled. The only way to disable XRAM after it was enabled is a reset.

The clear instruction for XMAP0 should be integrated in the program initialization routine before XRAM is used. In extremely noisy systems the user may have redundant clear instructions.

The control bit XMAP1 is relevant only if the XRAM is accessed. In this case the external  $\overline{RD}$  and  $\overline{WR}$  signals at P3.6 and P3.7 are not activated during the access, if XMAP1 is cleared. For debug purposes it might be useful to have these signals and the addresses at Ports 0.2 available. This is performed if XMAP1 is set.

The behaviour of Port 0 and P2 during a MOVX access depends on the control bits in register SYSCON and on the state of pin  $\overline{EA}$ . The table 1 lists the various operating conditions. It shows the following characteristics:

a) Use of P0 and P2 pins during the MOVX access.

Bus: The pins work as external address/data bus. If (internal) XRAM is accessed, the data written to the XRAM can be seen on the bus in debug mode.

I/O: The pins work as Input/Output lines under control of their latch.

b) Activation of the  $\overline{RD}$  and  $\overline{WR}$  pin during the access.

c) Use of internal or external XDATA memory.

The shaded areas describe the standard operation as each 80C51 device without on-chip XRAM behaves.

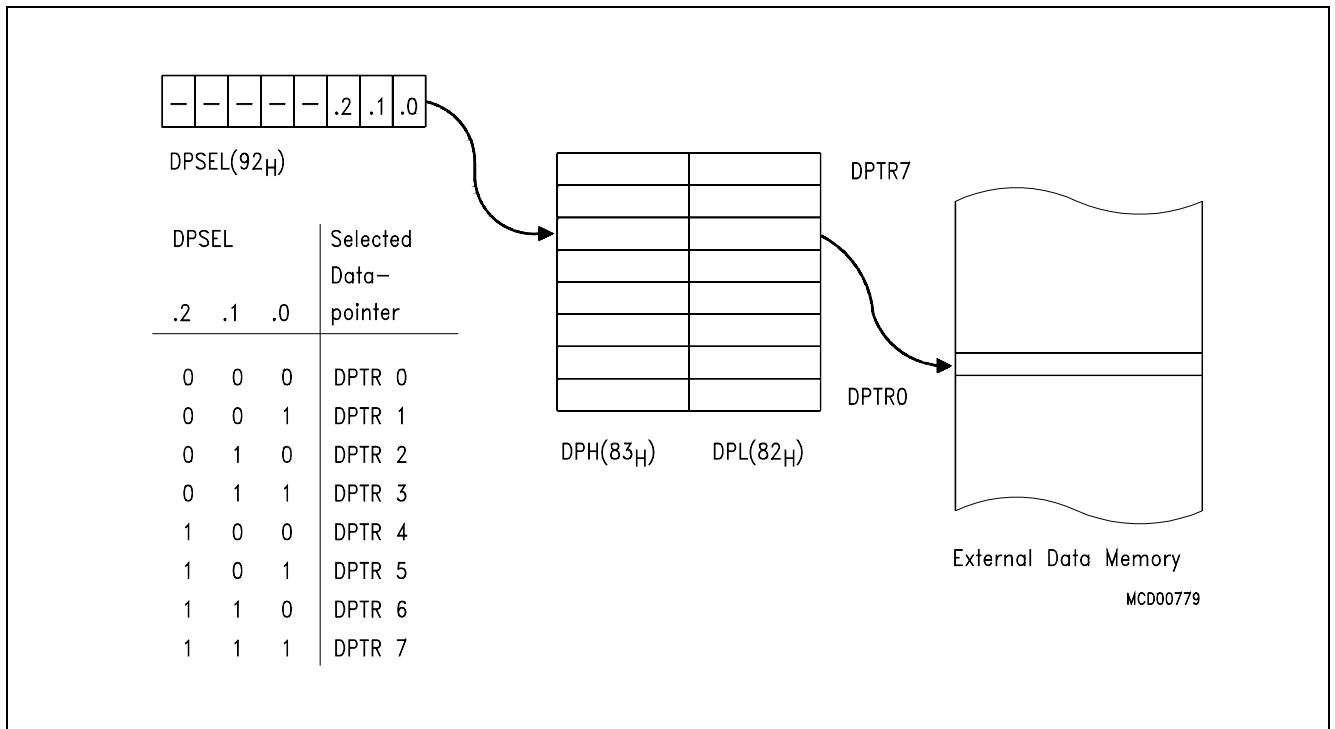
**Table 1:**  
**Behaviour of P0/P2 and RD/WR during MOVX accesses**

		<b>EA = 0</b>				<b>EA = 1</b>			
		<b>XMAP1, XMAP0</b>				<b>XMAP1, XMAP0</b>			
		<b>00</b>	<b>10</b>	<b>X1</b>	<b>00</b>	<b>10</b>	<b>X1</b>	<b>00</b>	<b>X1</b>
<b>MOVX @DPTR</b>	DPTR < XRAM address range	a) P0/P2 → Bus b) $\overline{RD}/\overline{WR}$ active c) ext. memory is used	a) P0/P2 → Bus b) $\overline{RD}/\overline{WR}$ active c) ext. memory is used	a) P0/P2 → Bus b) $\overline{RD}/\overline{WR}$ active c) ext. memory is used	a) P0/P2 → Bus b) $\overline{RD}/\overline{WR}$ active c) ext. memory is used	a) P0/P2 → Bus b) $\overline{RD}/\overline{WR}$ active c) ext. memory is used	a) P0/P2 → Bus b) $\overline{RD}/\overline{WR}$ active c) ext. memory is used	a) P0/P2 → Bus b) $\overline{RD}/\overline{WR}$ active c) ext. memory is used	a) P0/P2 → Bus b) $\overline{RD}/\overline{WR}$ active c) ext. memory is used
	DPTR ≥ XRAM address range	a) P0/P2 → BUS (WR -Data only) b) $\overline{RD}/\overline{WR}$ inactive c) XRAM is used	a) P0/P2 → BUS (WR -Data only) b) $\overline{RD}/\overline{WR}$ active c) XRAM is used	a) P0/P2 → Bus b) $\overline{RD}/\overline{WR}$ active c) ext. memory is used	a) P0/P2 → BUS (WR -Data only) b) $\overline{RD}/\overline{WR}$ active c) XRAM is used	a) P0/P2 → BUS (WR -Data only) b) $\overline{RD}/\overline{WR}$ active c) XRAM is used	a) P0/P2 → BUS (WR -Data only) b) $\overline{RD}/\overline{WR}$ active c) XRAM is used	a) P0/P2 → BUS (WR -Data only) b) $\overline{RD}/\overline{WR}$ active c) XRAM is used	a) P0/P2 → Bus b) $\overline{RD}/\overline{WR}$ active c) ext. memory is used
<b>MOVX @Ri</b>	XPAGE < XRAM page addr. range	a) P0 → Bus P2 → I/O b) $\overline{RD}/\overline{WR}$ active c) ext. memory is used	a) P0 → Bus P2 → I/O b) $\overline{RD}/\overline{WR}$ active c) ext. memory is used	a) P0 → Bus P2 → I/O b) $\overline{RD}/\overline{WR}$ active c) ext. memory is used	a) P0 → Bus P2 → I/O b) $\overline{RD}/\overline{WR}$ active c) ext. memory is used	a) P0 → Bus P2 → I/O b) $\overline{RD}/\overline{WR}$ active c) ext. memory is used	a) P0 → Bus P2 → I/O b) $\overline{RD}/\overline{WR}$ active c) ext. memory is used	a) P0 → Bus P2 → I/O b) $\overline{RD}/\overline{WR}$ active c) ext. memory is used	a) P0 → Bus P2 → I/O b) $\overline{RD}/\overline{WR}$ active c) ext. memory is used
	XPAGE ≥ XRAM page addr. range	a) P0/P2 → BUS (WR -Data only) P2 → I/O b) $\overline{RD}/\overline{WR}$ inactive c) XRAM is used	a) P0/P2 → BUS (WR -Data only) P2 → I/O b) $\overline{RD}/\overline{WR}$ active c) XRAM is used	a) P0 → Bus P2 → I/O b) $\overline{RD}/\overline{WR}$ active c) ext. memory is used	a) P0 → BUS (WR -Data only) P2 → I/O b) $\overline{RD}/\overline{WR}$ active c) XRAM is used	a) P0 → BUS (WR -Data only) P2 → I/O b) $\overline{RD}/\overline{WR}$ active c) XRAM is used	a) P0 → BUS (WR -Data only) P2 → I/O b) $\overline{RD}/\overline{WR}$ active c) XRAM is used	a) P0 → BUS (WR -Data only) P2 → I/O b) $\overline{RD}/\overline{WR}$ active c) XRAM is used	a) P0 → Bus P2 → I/O b) $\overline{RD}/\overline{WR}$ active c) ext. memory is used

modes compatible to 8051 - family

**Multiple Datapointers**

As a functional enhancement to standard 8051 controllers, the SAB 80C517A contains eight 16-bit datapointers. The instruction set uses just one of these datapointers at a time. The selection of the actual datapointer is done in special function register DPSEL (data pointer select, addr. 92H). Figure 3 illustrates the addressing mechanism.



**Figure 3**  
**Addressing of External Data Memory**

## Special Function Registers

All registers, except the program counter and the four general purpose register banks, reside in the special function register area. The 81 special function registers include arithmetic registers, pointers, and registers that provide an interface between the CPU and the on-chip peripherals. There are also 128 directly addressable bits within the SFR area. All special function registers are listed in table 1 and table 2.

In table 1 they are organized in numeric order of their addresses. In table 2 they are organized in groups which refer to the functional blocks of the SAB 80C517A.

**Table 2**  
**Special Function Register**

Address	Register	Contents after Reset	Address	Register	Contents after Reset
<b>80H</b>	<b>P0</b> <sup>1)</sup>	<b>0FFH</b>	<b>98H</b>	<b>S0CON</b> <sup>1)</sup>	<b>00H</b>
81H	SP	07H	99H	S0BUF	XXH
82H	DPL	00H	9AH	IEN2	XX00 00X0B
83H	DPH	00H	9BH	S1CON	0X00 0000B
84H	(WDTL) <sup>3)</sup>	(00H)	9CH	S1BUF	XXH
85H	(WDTH) <sup>3)</sup>	(00H)	9DH	S1RELL	00H
86H	WDTREL	00H	9EH	reserved	XXH
87H	PCON	00H	9FH	reserved	XXH
<b>88H</b>	<b>TCON</b> <sup>1)</sup>	<b>00H</b>	<b>A0H</b>	<b>P2</b> <sup>1)</sup>	<b>0FFH</b>
89H	TMOD	00H	A1H	COMSETL	00H
8AH	TL0	00H	A2H	COMSETH	00H
8BH	TL1	00H	A3H	COMCLRL	00H
8CH	TH0	00H	A4H	COMCLRH	00H
8DH	TH1	00H	A5H	SETMSK	00H
8EH	reserved	XXH <sup>2)</sup>	A6H	CLRMSK	00H
8FH	reserved	XXH <sup>2)</sup>	A7H	reserved	XXH <sup>2)</sup>
<b>90H</b>	<b>P1</b> <sup>1)</sup>	<b>0FFH</b>	<b>A8H</b>	<b>IEN0</b> <sup>1)</sup>	<b>00H</b>
91H	XPAGE	00H	A9H	IP0	00H
92H	DPSEL	XXXXX000B	AAH	S0RELL	0D9H
93H	reserved	XXH <sup>2)</sup>	ABH	reserved	XXH <sup>2)</sup>
94H	reserved	XXH <sup>2)</sup>	ACH	reserved	XXH <sup>2)</sup>
95H	reserved	XXH <sup>2)</sup>	ADH	reserved	XXH <sup>2)</sup>
96H	reserved	XXH <sup>2)</sup>	AEH	reserved	XXH <sup>2)</sup>
97H	reserved	XXH <sup>2)</sup>	AFH	reserved	XXH <sup>2)</sup>

<sup>1)</sup> Bit-addressable special function registers

<sup>2)</sup> X means that the value is indeterminate and the location is reserved

<sup>3)</sup> ( )... SFRs not user accessible

**Table 2**  
**Special Function Register (cont'd)**

Address	Register	Contents after Reset	Address	Register	Contents after Reset
<b>B0<sub>H</sub></b> B1 <sub>H</sub> B2 <sub>H</sub> B3 <sub>H</sub> B4 <sub>H</sub> B5 <sub>H</sub> B6 <sub>H</sub> B7 <sub>H</sub>	<b>P3</b> <sup>1)</sup> SYSCON reserved reserved reserved reserved reserved reserved	<b>0FF<sub>H</sub></b> XXXX XX01B XX <sub>H</sub> <sup>2)</sup> XX <sub>H</sub> <sup>2)</sup> XX <sub>H</sub> <sup>2)</sup> XX <sub>H</sub> <sup>2)</sup> XX <sub>H</sub> <sup>2)</sup> XX <sub>H</sub> <sup>2)</sup>	<b>D0<sub>H</sub></b> D1 <sub>H</sub> D2 <sub>H</sub> D3 <sub>H</sub> D4 <sub>H</sub> D5 <sub>H</sub> D6 <sub>H</sub> D7 <sub>H</sub>	<b>PSW</b> <sup>1)</sup> IRCON1 CML0 CMH0 CML1 CMH1 CML2 CMH2	<b>00<sub>H</sub></b> 00 <sub>H</sub> 00 <sub>H</sub> 00 <sub>H</sub> 00 <sub>H</sub> 00 <sub>H</sub> 00 <sub>H</sub> 00 <sub>H</sub>
<b>B8<sub>H</sub></b> B9 <sub>H</sub> BA <sub>H</sub> BB <sub>H</sub> BC <sub>H</sub> BD <sub>H</sub> BS <sub>H</sub> BF <sub>H</sub>	<b>IEN1</b> <sup>1)</sup> IP1 S0RELH S1RELH reserved reserved reserved reserved	<b>00<sub>H</sub></b> XX00 0000B XXXX XX11B XXXX XX11B XX <sub>H</sub> XX <sub>H</sub> XX <sub>H</sub> XX <sub>H</sub>	<b>D8<sub>H</sub></b> D9 <sub>H</sub> DA <sub>H</sub> DB <sub>H</sub> DC <sub>H</sub> DD <sub>H</sub> DE <sub>H</sub> DF <sub>H</sub>	<b>ADCON0</b> <sup>1)</sup> ADDATH ADDATL P7 ADCON1 P8 CTRELL CTRELH	<b>00<sub>H</sub></b> 00 <sub>H</sub> 00 <sub>H</sub> XX <sub>H</sub> XXXX 0000B XX <sub>H</sub> 00 <sub>H</sub> 00 <sub>H</sub>
<b>C0<sub>H</sub></b> C1 <sub>H</sub> C2 <sub>H</sub> C3 <sub>H</sub> C4 <sub>H</sub> C5 <sub>H</sub> C6 <sub>H</sub> C7 <sub>H</sub>	<b>IRCON0</b> <sup>1)</sup> CCEN CCL1 CCH1 CCL2 CCH2 CCL3 CCH3	<b>00<sub>H</sub></b> 00 <sub>H</sub> 00 <sub>H</sub> 00 <sub>H</sub> 00 <sub>H</sub> 00 <sub>H</sub> 00 <sub>H</sub> 00 <sub>H</sub>	<b>E0<sub>H</sub></b> E1 <sub>H</sub> E2 <sub>H</sub> E3 <sub>H</sub> E4 <sub>H</sub> E5 <sub>H</sub> E6 <sub>H</sub> E7 <sub>H</sub>	<b>ACC</b> <sup>1)</sup> CTCON CML3 CMH3 CML4 CMH4 CML5 CMH5	<b>00<sub>H</sub></b> 0X00 000B 00 <sub>H</sub> 00 <sub>H</sub> 00 <sub>H</sub> 00 <sub>H</sub> 00 <sub>H</sub> 00 <sub>H</sub>
<b>C8<sub>H</sub></b> C9 <sub>H</sub> CA <sub>H</sub> CB <sub>H</sub> CC <sub>H</sub> CD <sub>H</sub> CE <sub>H</sub> CF <sub>H</sub>	<b>T2CON</b> <sup>1)</sup> CC4EN CRCL CRCH TL2 TH2 CCL4 CCH4	<b>00<sub>H</sub></b> 00 <sub>H</sub> 00 <sub>H</sub> 00 <sub>H</sub> 00 <sub>H</sub> 00 <sub>H</sub> 00 <sub>H</sub> 00 <sub>H</sub>	<b>E8<sub>H</sub></b> E9 <sub>H</sub> EA <sub>H</sub> EB <sub>H</sub> EC <sub>H</sub> ED <sub>H</sub> EE <sub>H</sub> EF <sub>H</sub>	<b>P4</b> <sup>1)</sup> MD0 MD1 MD2 MD3 MD4 MD5 ARCON	<b>0FF<sub>H</sub></b> XX <sub>H</sub> XX <sub>H</sub> XX <sub>H</sub> XX <sub>H</sub> XX <sub>H</sub> XX <sub>H</sub> 0XXX XXXXB

<sup>1)</sup> Bit-addressable special function registers

<sup>2)</sup> X means that the value is indeterminate and the location is reserved

<sup>3)</sup> ( )... SFRs not user accessible



**Table 2**  
**Special Function Register (cont'd)**

Address	Register	Contents after Reset	Address	Register	Contents after Reset
<b>F0H</b>	<b>B</b> <sup>1)</sup>	<b>00H</b>	<b>F8H</b>	<b>P5</b> <sup>1)</sup>	<b>0FFH</b>
F1H	reserved	XXH	F9H	reserved	XXH
F2H	CML6	00H	FAH	P6	0FFH
F3H	CMH6	00H	FBH	reserved	XXH
F4H	CML7	00H	FBH	reserved	XXH
F5H	CMH7	00H	FDH	(IS0)	XXH
F6H	CMEN	00H	FEH	(IS1)	XXH
F7H	CMSEL	00H	FFH	reserved	XXH

<sup>1)</sup> Bit-addressable special function registers

<sup>2)</sup> X means that the value is indeterminate and the location is reserved

<sup>3)</sup> (...) SFRs not user accessible

**Table 3**  
**Special Function Registers - Functional Blocks**

Block	Symbol	Name	Address	Contents after Reset
CPU	ACC	Accumulator	<b>0E0<sub>H</sub></b> <sup>1)</sup>	00 <sub>H</sub>
	B	B-Register	<b>0F0<sub>H</sub></b> <sup>1)</sup>	00 <sub>H</sub>
	DPH	Data Pointer, High Byte	83 <sub>H</sub>	00 <sub>H</sub>
	DPL	Data Pointer, Low Byte	82 <sub>H</sub>	00 <sub>H</sub>
	DPSEL	Data Pointer Select Register	92 <sub>H</sub>	XXXX X000B <sup>3)</sup>
	PSW	Program Status Word Register	<b>0D0<sub>H</sub></b> <sup>1)</sup>	00 <sub>H</sub>
	SP	Stack Pointer	81 <sub>H</sub>	07 <sub>H</sub>
A/D-Converter	ADCON0	A/D Converter Control Register 0	<b>0D8<sub>H</sub></b> <sup>1)</sup>	00 <sub>H</sub>
	ADCON1	A/D Converter Control Register 1	0DC <sub>H</sub>	00 <sub>H</sub>
	ADDATH	A/D Converter Data Reg. High Byte	0D9 <sub>H</sub>	00 <sub>H</sub>
	ADDATL	A/D Converter Data Reg. Low Byte	0DA <sub>H</sub>	00 <sub>H</sub>
Interrupt System	IEN0	Interrupt Enable Register 0	<b>0A8<sub>H</sub></b> <sup>1)</sup>	00 <sub>H</sub>
	CTCON <sup>2)</sup>	Com. Timer Control Register	0E1 <sub>H</sub>	0X00 0000B
	IEN1	Interrupt Enable Register 1	<b>0B8<sub>H</sub></b> <sup>1)</sup>	00 <sub>H</sub>
	IEN2	Interrupt Enable Register 2	9A <sub>H</sub>	XX00 00X0B <sup>3)</sup>
	IP0	Interrupt Priority Register 0	0A9 <sub>H</sub>	00 <sub>H</sub>
	IP1	Interrupt Priority Register 1	0B9 <sub>H</sub>	XX00 0000B
	IRCON0	Interrupt Request Control Register	<b>0C0<sub>H</sub></b> <sup>1)</sup>	00 <sub>H</sub>
	IRCON1	Interrupt Request Control Register	0D1 <sub>H</sub>	00 <sub>H</sub>
	TCON <sup>2)</sup>	Timer Control Register	<b>88<sub>H</sub></b> <sup>1)</sup>	00 <sub>H</sub>
TCON <sup>2)</sup>	Timer 2 Control Register	<b>0C8<sub>H</sub></b>	00 <sub>H</sub>	
MUL/DIV Unit	ARCON	Arithmetic Control Register	0EF <sub>H</sub>	0XXXX XXXXB
	MD0	Multiplication/Division Register 0	0E9 <sub>H</sub>	XX <sub>H</sub>
	MD1	Multiplication/Division Register 1	0EA <sub>H</sub>	XX <sub>H</sub>
	MD2	Multiplication/Division Register 2	0EB <sub>H</sub>	XX <sub>H</sub>
	MD3	Multiplication/Division Register 3	0EC <sub>H</sub>	XX <sub>H</sub>
	MD4	Multiplication/Division Register 4	0ED <sub>H</sub>	XX <sub>H</sub>
	MD5	Multiplication/Division Register 5	0EE <sub>H</sub>	XX <sub>H</sub>

<sup>1)</sup> Bit-addressable special function registers

<sup>2)</sup> This special function register is listed repeatedly since some bits of it also belong to other functional blocks.

<sup>3)</sup> X means that the value is indeterminate and the location is reserved

**Table 3**  
**Special Function Registers - Functional Blocks (cont'd)**

Block	Symbol	Name	Address	Contents after Reset
Compare/ Capture- Unit (CCU) Timer 2	CCEN	Comp./Capture Enable Reg.	0C1 <sub>H</sub>	00 <sub>H</sub>
	CC4EN	Comp./Capture Enable 4 Reg.	0C9 <sub>H</sub>	00 <sub>H</sub>
	CCH1	Comp./Capture Reg. 1, High Byte	0C3 <sub>H</sub>	00 <sub>H</sub>
	CCH2	Comp./Capture Reg. 2, High Byte	0C5 <sub>H</sub>	00 <sub>H</sub>
	CCH3	Comp./Capture Reg. 3, High Byte	0C7 <sub>H</sub>	00 <sub>H</sub>
	CCH4	Comp./Capture Reg. 4, High Byte	0CF <sub>H</sub>	00 <sub>H</sub>
	CCL1	Comp./Capture Reg. 1, Low Byte	0C2 <sub>H</sub>	00 <sub>H</sub>
	CCL2	Comp./Capture Reg. 2, Low Byte	0C4 <sub>H</sub>	00 <sub>H</sub>
	CCL3	Comp./Capture Reg. 3, Low Byte	0C6 <sub>H</sub>	00 <sub>H</sub>
	CCL4	Comp./Capture Reg. 4, Low Byte	0CE <sub>H</sub>	00 <sub>H</sub>
	CMEN	Compare Enable Register	0F6 <sub>H</sub>	00 <sub>H</sub>
	CMH0	Compare Register 0, High Byte	0D3 <sub>H</sub>	00 <sub>H</sub>
	CMH1	Compare Register 1, High Byte	0D5 <sub>H</sub>	00 <sub>H</sub>
	CMH2	Compare Register 2, High Byte	0D7 <sub>H</sub>	00 <sub>H</sub>
	CMH3	Compare Register 3, High Byte	0E3 <sub>H</sub>	00 <sub>H</sub>
	CMH4	Compare Register 4, High Byte	0E5 <sub>H</sub>	00 <sub>H</sub>
	CMH5	Compare Register 5, High Byte	0E7 <sub>H</sub>	00 <sub>H</sub>
	CMH6	Compare Register 6, High Byte	0F3 <sub>H</sub>	00 <sub>H</sub>
	CMH7	Compare Register 7, High Byte	0F5 <sub>H</sub>	00 <sub>H</sub>
	CML0	Compare Register 0, Low Byte	0D2 <sub>H</sub>	00 <sub>H</sub>
	CML1	Compare Register 1, Low Byte	0D4 <sub>H</sub>	00 <sub>H</sub>
	CML2	Compare Register 2, Low Byte	0D6 <sub>H</sub>	00 <sub>H</sub>
	CML3	Compare Register 3, Low Byte	0E2 <sub>H</sub>	00 <sub>H</sub>
	CML4	Compare Register 4, Low Byte	0E4 <sub>H</sub>	00 <sub>H</sub>
	CML5	Compare Register 5, Low Byte	0E6 <sub>H</sub>	00 <sub>H</sub>
	CML6	Compare Register 6, Low Byte	0F2 <sub>H</sub>	00 <sub>H</sub>
	CML7	Compare Register 7, Low Byte	0F4 <sub>H</sub>	00 <sub>H</sub>
	CMSEL	Compare Input Select	0F7 <sub>H</sub>	00 <sub>H</sub>
	CRCH	Com./Rel./Capt. Reg. High Byte	0CB <sub>H</sub>	00 <sub>H</sub>
	CRCL	Com./Rel./Capt. Reg. Low Byte	0CA <sub>H</sub>	00 <sub>H</sub>
	COMSETL	Compare Register, Low Byte	0A1 <sub>H</sub>	00 <sub>H</sub>
	COMSETH	Compare Register, High Byte	0A2 <sub>H</sub>	00 <sub>H</sub>
	COMCLRL	Compare Register, Low Byte	0A3 <sub>H</sub>	00 <sub>H</sub>
	COMCLRH	Compare Register, High Byte	0A4 <sub>H</sub>	00 <sub>H</sub>
	SETMSK	Mask Register, concerning COMSET	0A5 <sub>H</sub>	00 <sub>H</sub>

<sup>1)</sup> Bit-addressable special function registers

<sup>2)</sup> This special function register is listed repeatedly since some bits of it also belong to other functional blocks.

<sup>3)</sup> X means that the value is indeterminate and the location is reserved

**Table 3**  
**Special Function Registers - Functional Blocks (cont'd)**

Block	Symbol	Name	Address	Contents after Reset
Compare/ Capture- Unit (CCU), (cont'd)	CLRMSK	Mask Register, concerning COMCLR	0A6 <sub>H</sub>	00 <sub>H</sub>
	CTCON	Com. Timer Control Reg.	0E1 <sub>H</sub>	0X00 0000B <sup>3)</sup>
	CTRELH	Com. Timer Rel. Reg., High Byte	0DF <sub>H</sub>	00 <sub>H</sub>
	CTRELL	Com. Timer Rel. Reg., Low Byte	0DE <sub>H</sub>	00 <sub>H</sub>
	TH2	Timer 2, High Byte	0CD <sub>H</sub>	00 <sub>H</sub>
	TL2	Timer 2, Low Byte	0CC <sub>H</sub>	00 <sub>H</sub>
	T2CON	Timer 2 Control Register	<b>0C8<sub>H</sub></b> <sup>1)</sup>	00 <sub>H</sub>
Ports	P0	Port 0	<b>80<sub>H</sub></b> <sup>1)</sup>	0FF <sub>H</sub>
	P1	Port 1	<b>90<sub>H</sub></b> <sup>1)</sup>	0FF <sub>H</sub>
	P2	Port 2	<b>0A0<sub>H</sub></b> <sup>1)</sup>	0FF <sub>H</sub>
	P3	Port 3	<b>0B0<sub>H</sub></b> <sup>1)</sup>	0FF <sub>H</sub>
	P4	Port 4	<b>0E8<sub>H</sub></b> <sup>1)</sup>	0FF <sub>H</sub>
	P5	Port 5	<b>0F8<sub>H</sub></b> <sup>1)</sup>	0FF <sub>H</sub>
	P6	Port 6,	0FA <sub>H</sub>	0FF <sub>H</sub>
	P7	Port 7, Analog/Digital Input	0DB <sub>H</sub>	
	P8	Port 8, Analog/Digital Input, 4-bit	0DD <sub>H</sub>	
Pow.Sav. Modes	PCON	Power Control Register	87 <sub>H</sub>	00 <sub>H</sub>
Serial Channels	ADCON <sup>02)</sup>	A/D Converter Control Reg.	<b>0D8<sub>H</sub></b> <sup>1)</sup>	00 <sub>H</sub>
	PCON <sup>2)</sup>	Power Control Register	87 <sub>H</sub>	00 <sub>H</sub>
	S0BUF	Serial Channel 0 Buffer Reg.	99 <sub>H</sub>	0XX <sub>H</sub> <sup>3)</sup>
	S0CON	Serial Channel 0 Control Reg.	<b>98<sub>H</sub></b> <sup>1)</sup>	00 <sub>H</sub>
	S0RELL	Serial Channel 0 Reload Reg., low byte	B2 <sub>H</sub>	D9 <sub>H</sub>
	S0RELH	Serial Channel 0 Reload Reg., high byte	BA <sub>H</sub>	XXXX.XX11B <sup>3)</sup>
	S1BUF	Serial Channel 1 Buffer Reg.,	9C <sub>H</sub>	0XX <sub>H</sub> <sup>3)</sup>
	S1CON	Serial Channel 1 Control Reg.	9B <sub>H</sub>	0X00 000B <sup>3)</sup>
	S1RELL	Serial Channel 1 Reload Reg., low byte	9D <sub>H</sub>	00 <sub>H</sub>
	S1RELH	Serial Channel 1 Reload Reg., high byte	BB <sub>H</sub>	XXXX.XX11B <sup>3)</sup>

<sup>1)</sup> Bit-addressable special function registers

<sup>2)</sup> This special function register is listed repeatedly since some bits of it also belong to other functional blocks.

<sup>3)</sup> X means that the value is indeterminate and the location is reserved

**Table 3**  
**Special Function Registers - Functional Blocks (cont'd)**

Block	Symbol	Name	Address	Contents after Reset
Timer 0/ Timer 1	TCON	Timer Control Register	<b>88H</b> <sup>1)</sup>	00H
	TH0	Timer 0, High Byte	8CH	00H
	TH1	Timer 1, High Byte	8DH	00H
	TL0	Timer 0, Low Byte	8AH	00H
	TL1	Timer 1, Low Byte	8BH	00H
	TMOD	Timer Mode Register	89H	00H
Watchdog	IEN0 <sup>2)</sup>	Interrupt Enable Register 0	<b>0A8H</b> <sup>1)</sup>	00H
	IEN1 <sup>2)</sup>	Interrupt Enable Register 1	<b>0B8H</b> <sup>1)</sup>	00H
	IP0 <sup>2)</sup>	Interrupt Priority Register 0	0A9H	00H
	IP1 <sup>2)</sup>	Interrupt Priority Register 1	0B9H	XX00 0000B <sup>3)</sup>
	WDTREL	Watchdog Timer Reload Reg.	86H	00H

<sup>1)</sup> Bit-addressable special function registers

<sup>2)</sup> This special function register is listed repeatedly since some bits of it also belong to other functional blocks.

<sup>3)</sup> X means that the value is indeterminate and the location is reserved

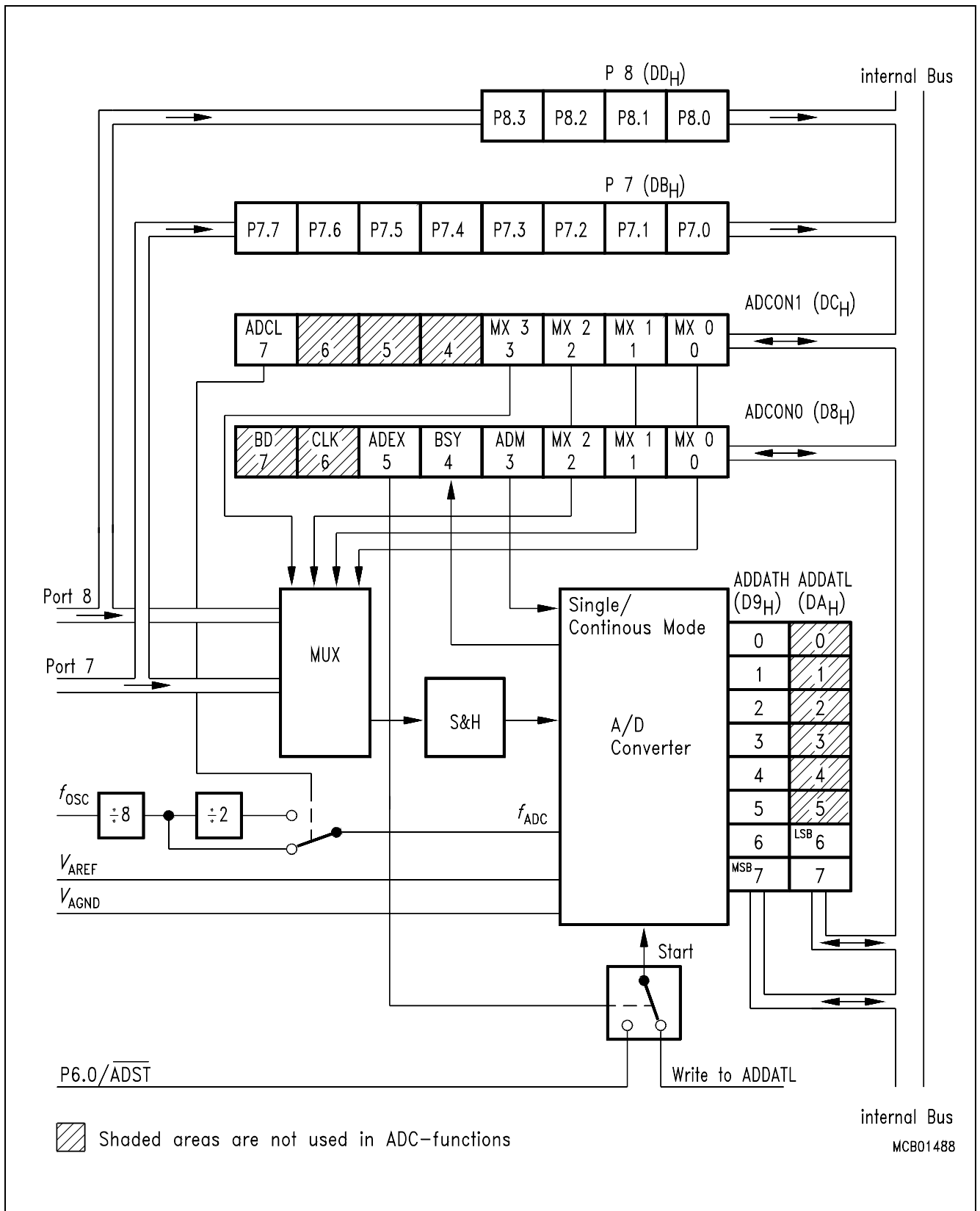
### A/D Converter

In the SAB 80C517A a new high performance / high-speed 12-channel 10-bit A/D-Converter is implemented. Its successive approximation technique provides 7  $\mu\text{s}$  conversion time ( $f_{\text{OSC}} = 16$  MHz). The conversion principle is upward compatible to the one used in the SAB 80C517. The main functional blocks are shown in figure 4.

The comparator is a fully differential comparator for a high power supply rejection ratio and very low offset voltages. The capacitor network is binary weighted providing genuine 10-bit resolution.

The table below shows the sample time  $T_S$  and the conversion time  $T_C$ , which are dependent on  $f_{\text{OSC}}$  and a new prescaler (see also Bit ADCL in SFR ADCON 1).

$f_{\text{OSC}}$ [MHz]	Prescaler	$f_{\text{ADC}}$ [MHz]	Sample Time $T_S$ [ $\mu\text{s}$ ]	Conversion Time (incl. sample time) $T_C$ [ $\mu\text{s}$ ]
12	$\div 8$	1.5	2.67	9.33
	$\div 16$	0.75	5.33	18.66
16	$\div 8$	2.0	2.0	7.0
	$\div 16$	1.0	4.0	14.0
18	$\div 8$	—	—	—
	$\div 16$	1.125	3.55	12.4



**Figure 4**  
**Block Diagram A/D Converter**

### Compare/Capture Unit (CCU)

The compare/capture unit is a complex timer/register array for applications that require high speed I/O pulse width modulation and more timer/counter capabilities.

The CCU contains

- one 16-bit timer/counter (**timer2**) with 2-bit prescaler, reload capability and a max. clock frequency of  $f_{OSC/12}$  (1 MHz with a 12 MHz crystal).
- one 16-bit timer (**compare timer**) with 8-bit prescaler, reload capability and a max. clock frequency of  $f_{OSC/2}$  (6 MHz with a 12 MHz crystal).
- fifteen 16-bit compare registers.
- five of which can be used as 16-bit capture registers.
- up to 21 output lines controlled by the CCU.
- nine interrupts which can be generated by CCU-events.

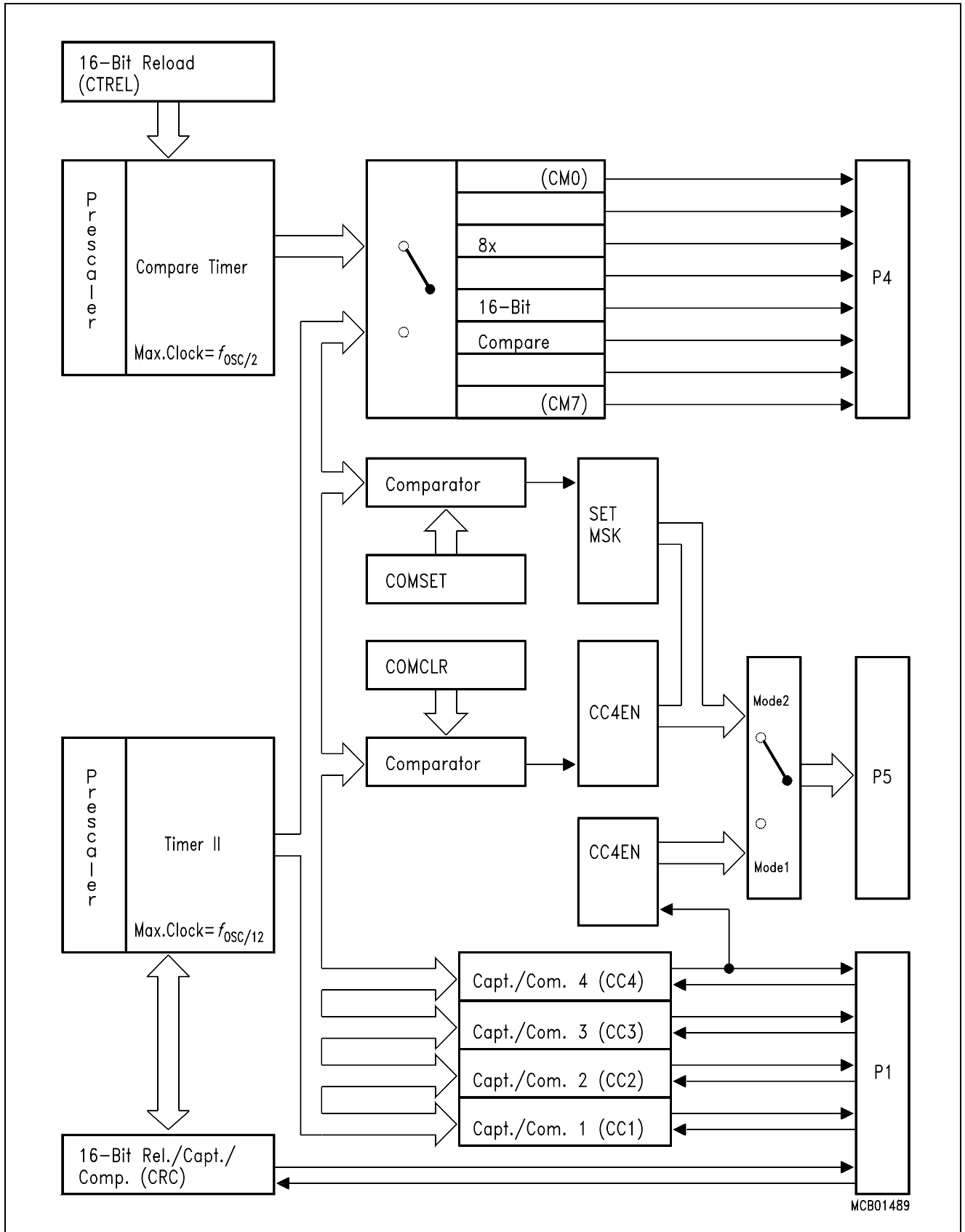
Figure 5 shows a block diagram of the CCU. Eight compare registers (CM0 to CM7) can individually be assigned to either timer 2 or the compare timer. Diagrams of the two timers are shown in figures 6 and 7. The four compare/capture registers, the compare/reload/capture register and the comset/comclr register are always connected to timer 2. Depending on the register type and the assigned timer three different compare modes can be selected.

Table 3 illustrates possible combinations and the corresponding output lines.



**Table 4**  
**CCU Compare Configuration**

Assigned Timer	Compare Register	Compare Output	Possible Modes
Timer 2	CRCH/CRCL	P1.0/ $\overline{\text{INT3}}$ /CC0	Comp. mode 0, 1 + Reload
	CC1H/CC1L	P1.1/INT4/CC1	Comp. mode 0, 1
	CC2H/CC2L	P1.2/INT5/CC2	Comp. mode 0, 1
	CC3H/CC3L	P1.3/INT6/CC3	Comp. mode 0, 1
	CC4H/CC4L	P1.4/ $\overline{\text{INT2}}$ /CC4	Comp. mode 0, 1
	CC4H/CC4L	P5.0/CCM0	Comp. mode 1
	:	:	:
	CC4H/CC4L	P5.7/CCM7	Comp. mode 1
	COMSETL/COMSETH	P5.0/CCM0	Comp. mode 2
		:	:
		P5.7/CCM7	Comp. mode 2
	COMCLRL/ COMCLRH	P5.0/CCM0	Comp. mode 2
		:	:
		P5.7/CCM7	Comp. mode 2
CM0H/CM0L	P4.0/CM0	Comp. mode 1	
:	:	:	
CM7H/CM7L	P4.7/CM7	Comp. mode 1	
Compare timer	CM0H/CM0L	P4.0/CM0	Comp. mode 0 (with shadow latches)
	:	:	:
	CM7H/CM7L	P4.7/CM7	Comp. mode 0 (with shadow latches)



**Figure 5**  
**Block Diagram of the Compare/Capture Unit**

## Compare

In compare mode, the 16-bit values stored in the dedicated compare registers are compared to the contents of the timer 2 register or the compare timer register. If the count value in the timer registers matches one of the stored value, an appropriate output signal is generated at the corresponding pin(s) and an interrupt is requested. Three compare modes are provided:

- Mode 0: Upon a match the output signal changes from low to high. It returns to low level at timer overflow.
- Mode 1: The transition of the output signal can be determined by software. A timer overflow signal does not affect the compare-output.
- Mode 2: In compare mode 2 the concurrent compare output pins on Port 5 are used as follows (see figure 9)
- When a compare match occurs with register COMSET, a high level appears at the pins of port 5 whose corresponding bits in the mask register SETMSK (address 0A5H) are set.
  - When a compare match occurs in register COMCLR, a low level appears at the pins of port 5 whose corresponding bits in the mask register CLRMSK (address 0A6H) are set.
- Additionally the Port 5 pins used for compare mode 2 may also be directly written to by write instructions to SFR P5. Of course, the pins can also be read under program control.

Compare registers CM0 to CM7 use additional compare latches when operated in mode 0. Figure 8 shows the function of these latches. The latches are implemented to prevent from loss of compare matches which may occur when loading of the compare values is not correlated with the timer count. The compare latches are automatically loaded from the compare registers at every timer overflow.

## Capture

This feature permits saving of the actual timer/counter contents into a selected register upon an external event or a software write operation. Two modes are provided to 'freeze' the current 16-bit value of timer 2 registers into a dedicated capture register.

- Mode 0: Capture is performed in response to a transition at the corresponding port 1 pins CC0 to CC3.
- Mode 1: Write operation into the low-order byte of the dedicated capture register causes the timer 2 contents to be latched into this register.

**Reload of Timer 2**

A 16-bit reload can be performed with the 16-bit CRC register, which is a concatenation of the 8-bit registers CRCL and CRCH. There are two modes from which to select:

Mode 0: Reload is caused by a timer overflow (auto-reload).

Mode 1: Reload is caused in response to a negative transition at pin T2EX (P1.5), which can also request an interrupt.

**Timer/Counters 0 and 1**

These timer/counters are fully compatible with timer/counter 0 or 1 of the SAB 8051 and can operate in four modes:

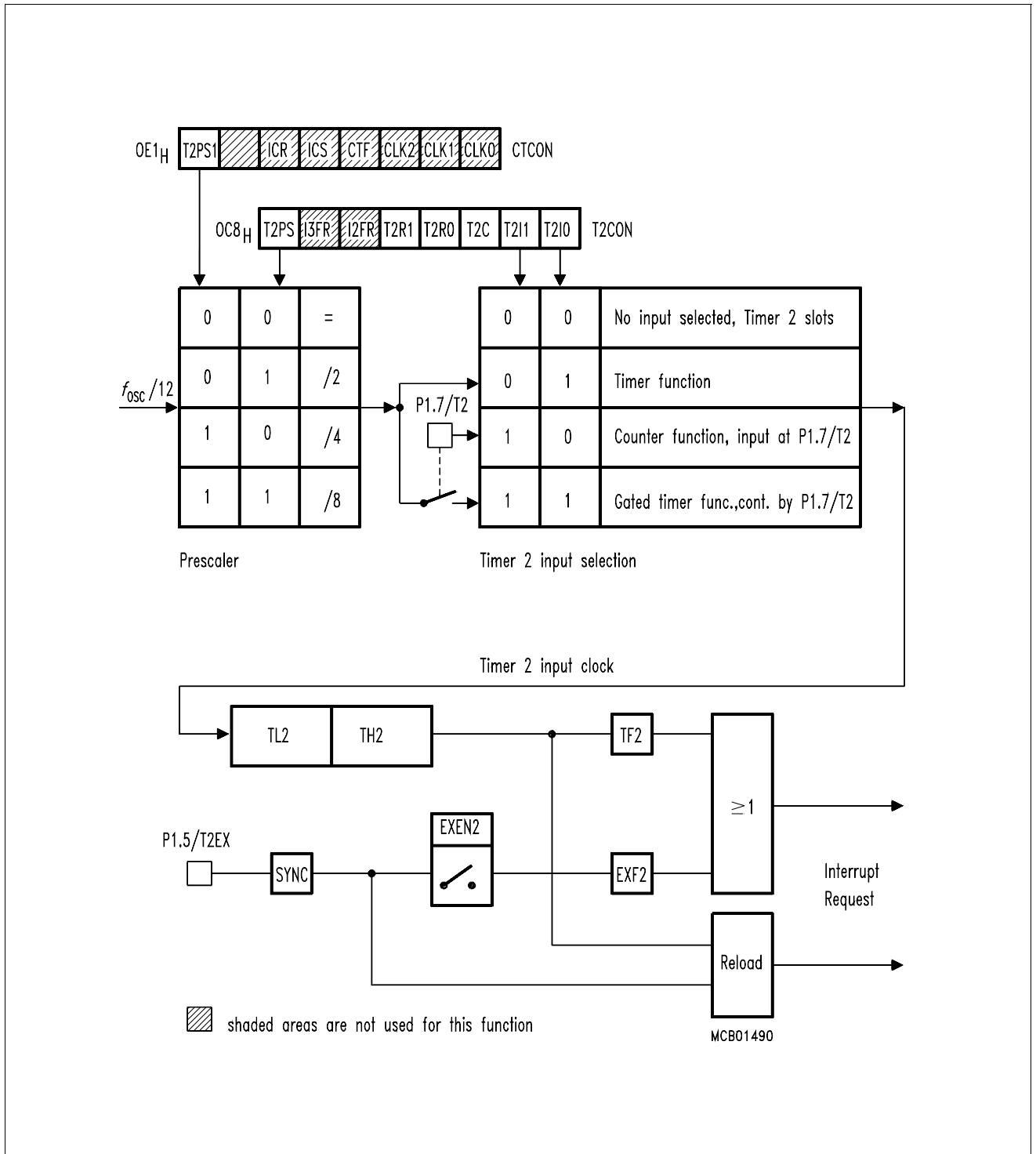
Mode 0: 8-bit timer/counter with 32:1 prescaler

Mode 1: 16-bit timer/counter

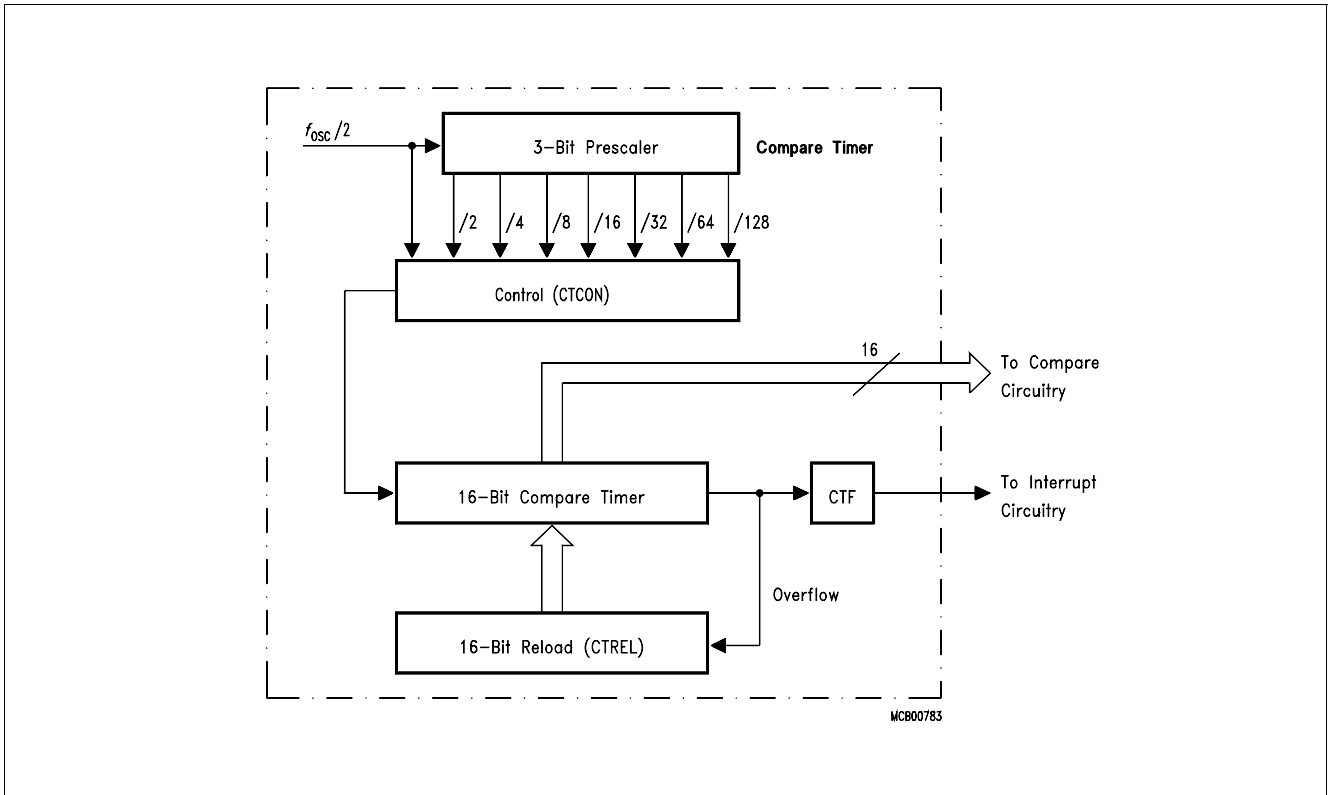
Mode 2: 8-bit timer/counter with 8-bit auto reload

Mode 3: Timer/counter 0 is configured as one 8-bit timer; timer/counter 1 in this mode holds its count.

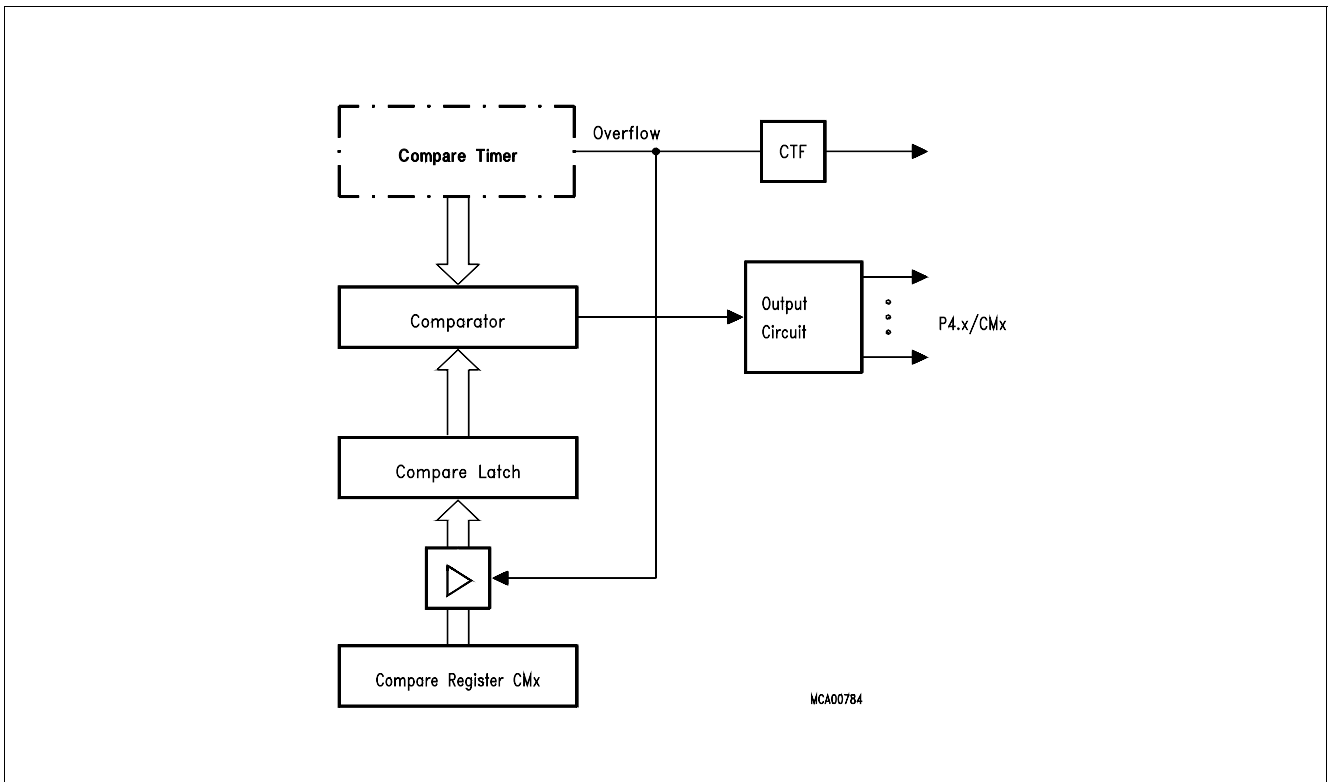
External inputs  $\overline{\text{INT0}}$  and  $\overline{\text{INT1}}$  can be programmed to function as a gate for timer/counters 0 and 1 to facilitate pulse width measurements.



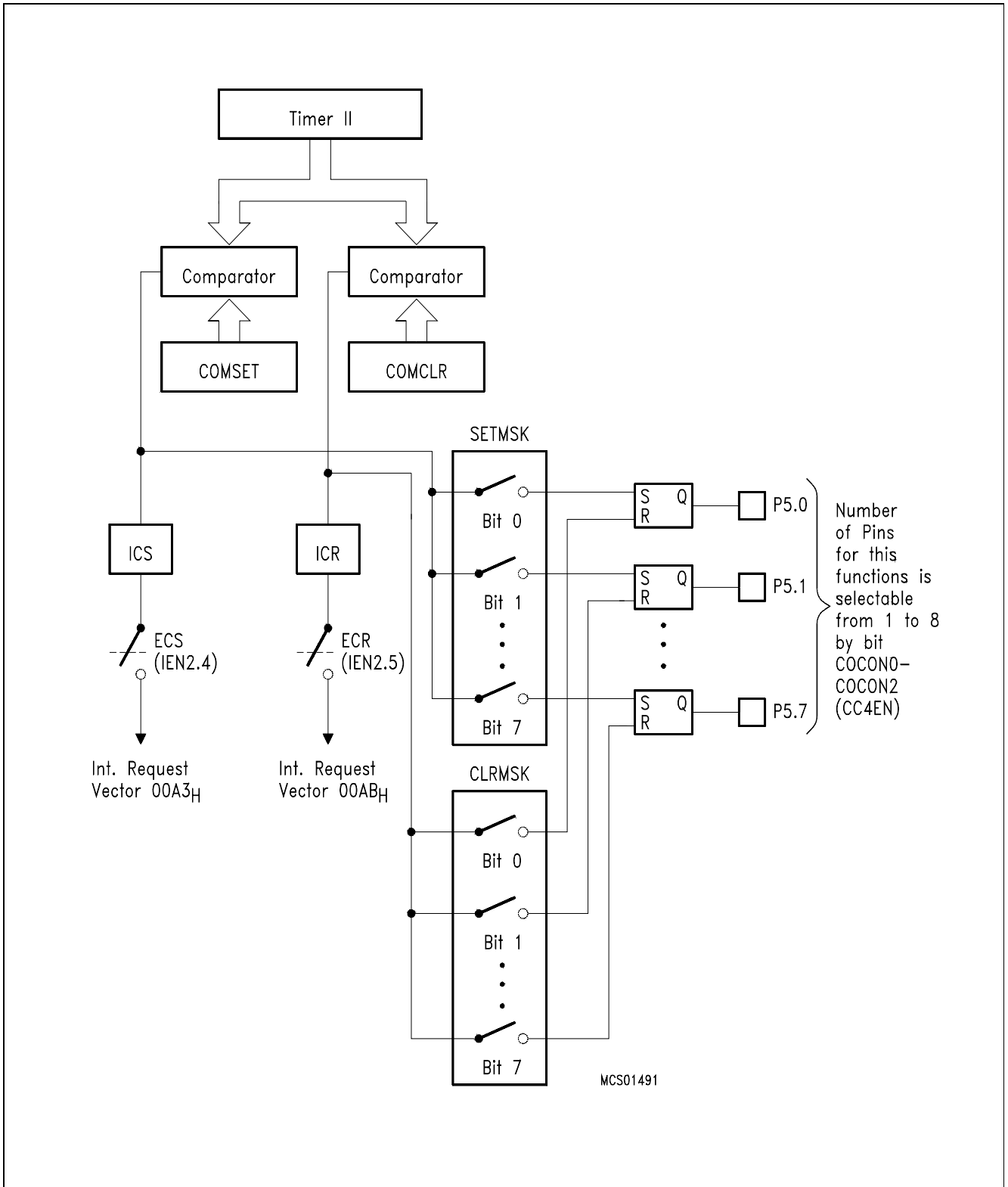
**Figure 6**  
**Block Diagram of Timer 2**



**Figure 7**  
**Block Diagram of the Compare Timer**



**Figure 8**  
**Compare-Mode 0 with Registers CM0 to CM7**



**Figure 9**  
**Compare-Mode 2 (Port 5 only)**

### Interrupt Structure

The SAB 80C517A has 17 interrupt vectors with the following vector addresses and request flags.

**Table 5**  
**Interrupt Sources and Vectors**

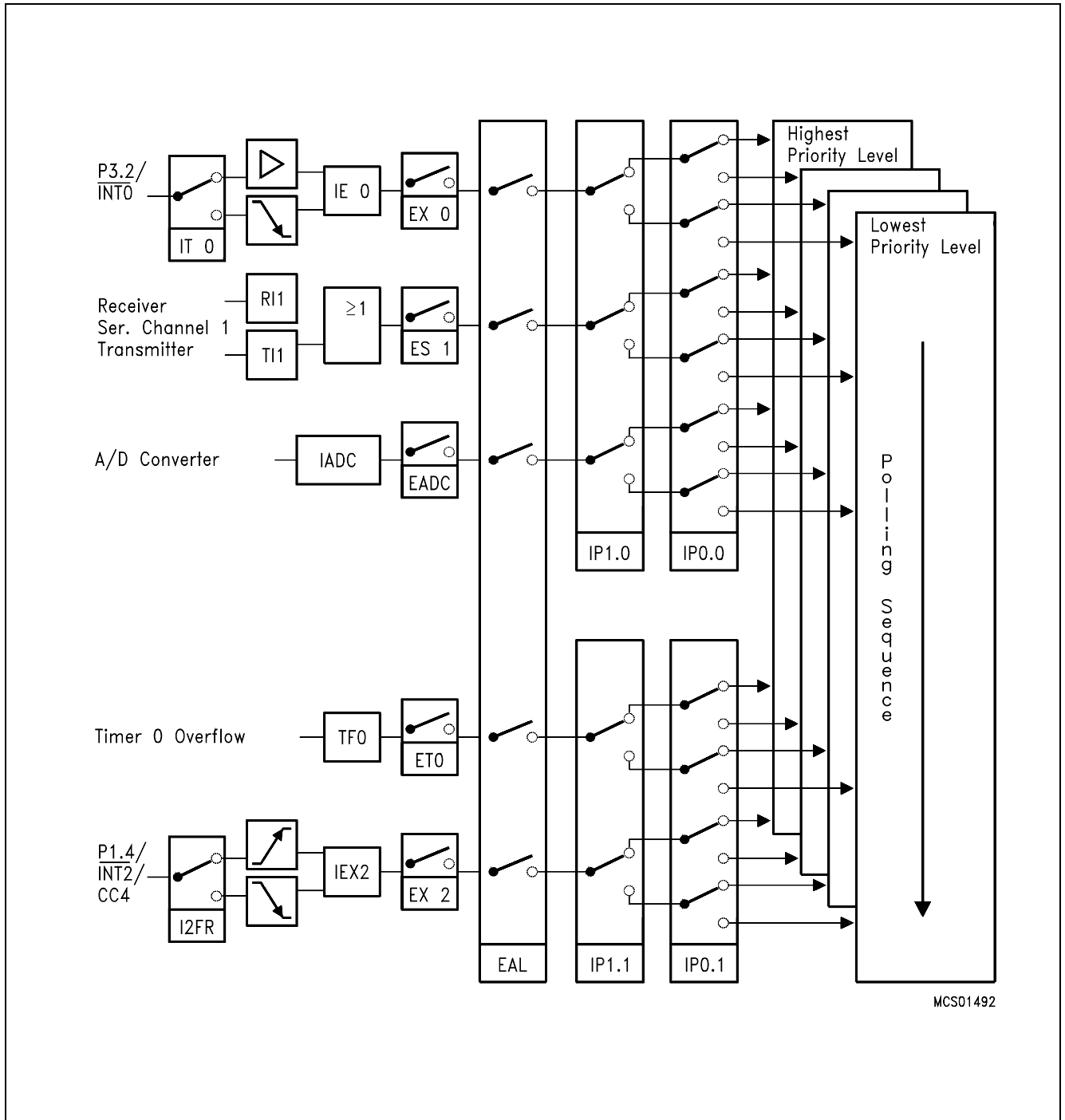
Interrupt Request Flags	Interrupt Vector Address	Interrupt Source
IE0	0003 <sub>H</sub>	External interrupt 0
TF0	000B <sub>H</sub>	Timer 0 overflow
IE1	0013 <sub>H</sub>	External interrupt 1
TF1	001B <sub>H</sub>	Timer 1 overflow
RI0 + TI0	0023 <sub>H</sub>	Serial channel 0
TF2 + EXF2	002B <sub>H</sub>	Timer 2 overflow/ext. reload
IADC	0043 <sub>H</sub>	A/D converter
IEX2	004B <sub>H</sub>	External interrupt 2
IEX3	0053 <sub>H</sub>	External interrupt 3
IEX4	005B <sub>H</sub>	External interrupt 4
IEX5	0063 <sub>H</sub>	External interrupt 5
IEX6	006B <sub>H</sub>	External interrupt 6
RI1/TI1	0083 <sub>H</sub>	Serial channel 1
ICMP0 to ICMP7	0093 <sub>H</sub>	Compare match interrupt of Compare Registers CM0-CM7 assigned to Timer 2
CTF	009B <sub>H</sub>	Compare timer overflow
ICS	00A3 <sub>H</sub>	Compare match interrupt of Compare Register COMSET
ICR	00AB <sub>H</sub>	Compare match interrupt of Compare Register COMCLR

Each interrupt vector can be individually enabled/disabled. The response time to an interrupt request is more than 3 machine cycles and less than 9 machine cycles.

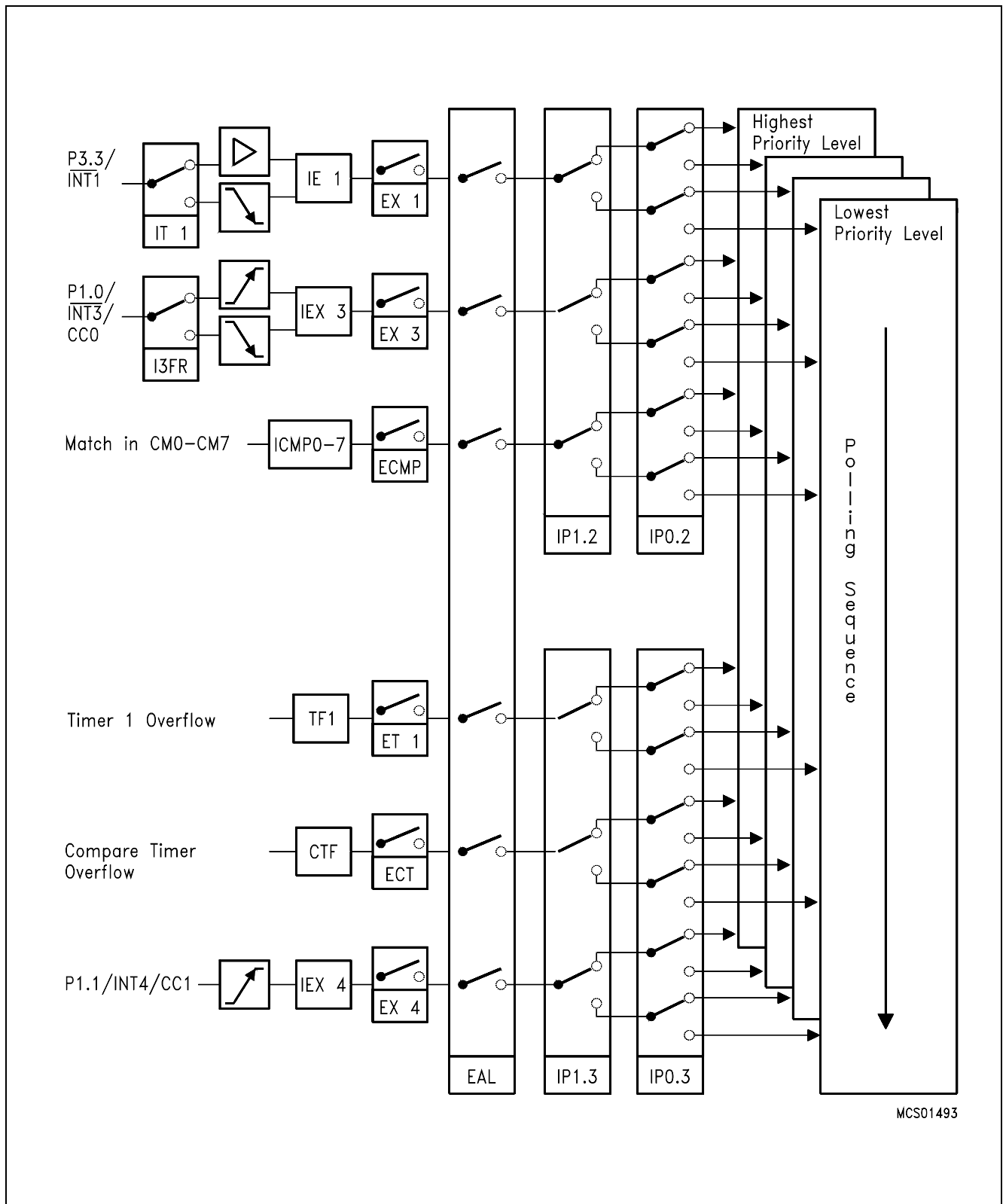
External interrupts 0 and 1 can be activated by a low-level or a negative transition (selectable) at their corresponding input pin, external interrupts 2 and 3 can be programmed for triggering on a negative or a positive transition. The external interrupts 2 to 6 are combined with the corresponding alternate functions compare (output) and capture (input) on port 1.

For programming of the priority levels the interrupt vectors are combined to pairs or triples. Each pair or triple can be programmed individually to one of four priority levels by setting or clearing one bit in special function register IP0 and one in IP1. Figure 9 shows the interrupt request sources, the enabling and the priority level structure.

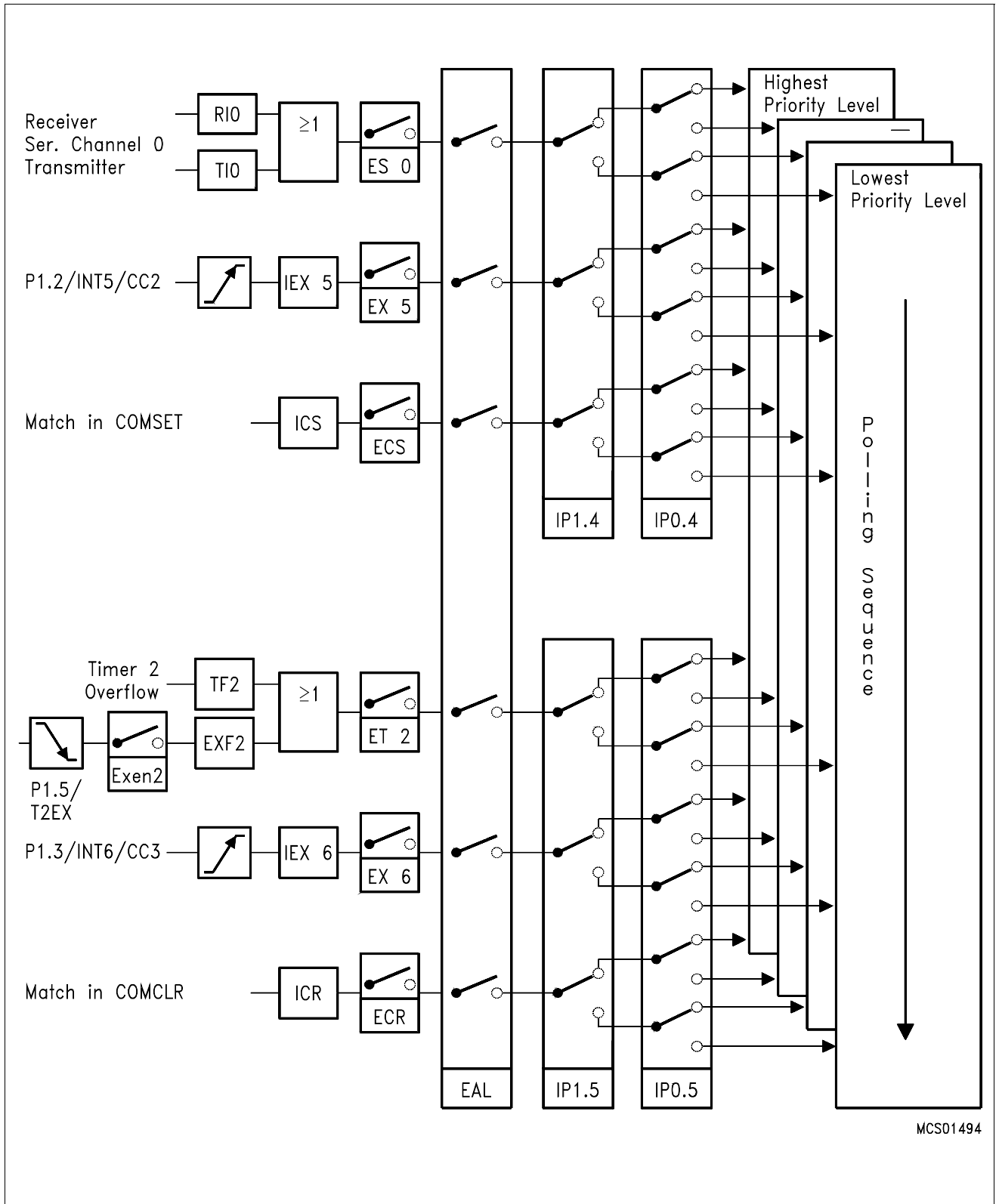




**Figure 10**  
**Interrupt Structure of the SAB 80C517A**



**Figure 10**  
**Interrupt Structure of the SAB 80C517A (cont'd)**



**Figure 10**  
**Interrupt Structure of the SAB 80C517A (cont'd)**

**Multiplication/Division Unit**

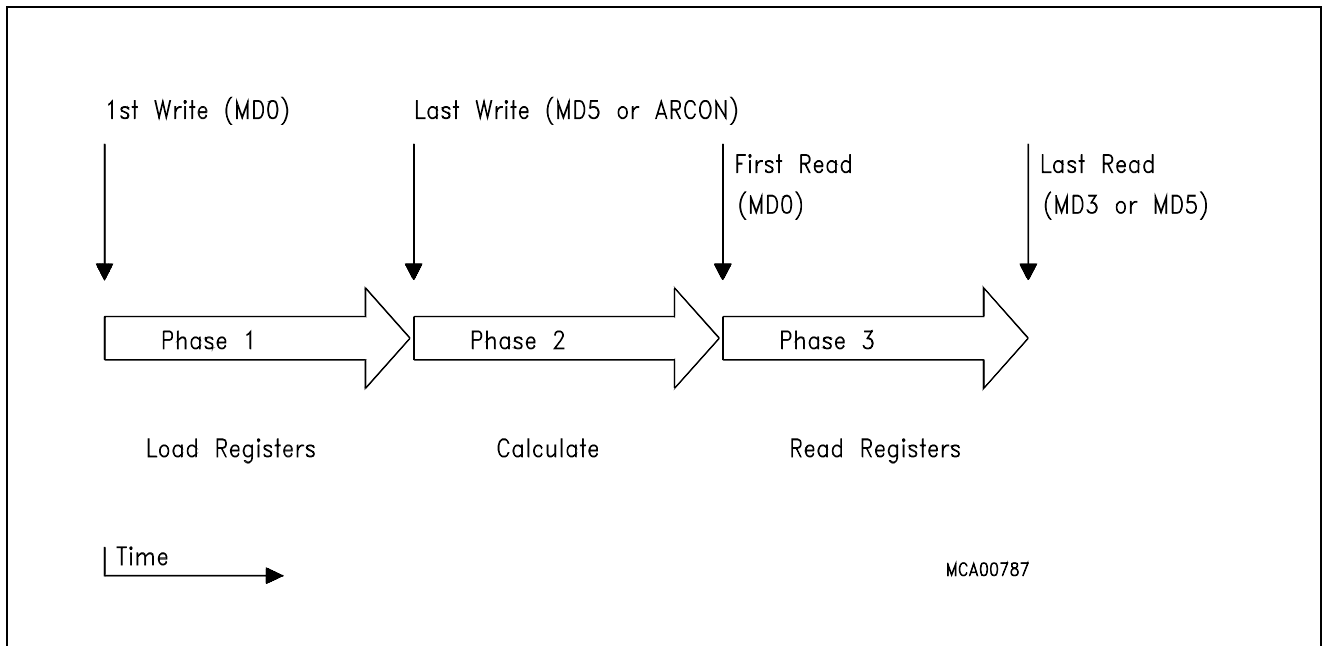
This on-chip arithmetic unit provides fast 32-bit division, 16-bit multiplication as well as shift and normalize features. All operations are integer operation.

Operation	Result	Remainder	Execution Time
32-bit/16-bit	32-bit	16-bit	6 $t_{cy}^{1)}$
16-bit/16-bit	16-bit	16-bit	4 $t_{cy}$
16-bit *16-bit	32-bit	–	4 $t_{cy}$
32-bit normalize	–	–	6 $t_{cy}^{2)}$
32-bit shift left/right	–	–	6 $t_{cy}^{2)}$

1) 1  $t_{cy}$  = 1  $\mu s$  @ 12 MHz oscillator frequency.

2) The maximal shift speed is 6 shifts/cycle.

The MDU consists of six registers used for operands and results and one control register. Operation of the MDU can be divided in three phases:



**Operation of the MDU**

To start an operation, register MD0 to MD5 (or ARCON) must be written to in a certain sequence according to table 5 or 6. The order the registers are accessed determines the type of the operation. A shift operation is started by a final write operation to register ARCON (see also the register description).

**Table 6**  
**Performing a MDU-Calculation**

Operation	32 Bit/16 Bit		16 Bit/16 Bit		16 Bit * 16 Bit	
First Write	MD0	D'endL	MD0	D'endL	MD0	M'andL
	MD1	D'end	MD1	D'endH	MD4	M'orL
	MD2	D'end				
	MD3	D'endH	MD4	D'orL	MD1	M'andH
	MD4	D'orL				
Last Write	MD5	D'orH	MD5	D'orH	MD5	M'orH
First Read	MD0	QuoL	MD0	QuoL	MD0	PrL
	MD1	Quo	MD1	QuoH	MD1	
	MD2	Quo				
	MD3	QuoH	MD4	RemL	MD2	
	MD4	RemL				
Last Read	MD5	RemH	MD5	RemH	MD3	PrH

**Table 7**  
**Shift Operation with the MDU**

Operation	Normalize, Shift Left, Shift Right	
First Write	MD0	least significant byte
	MD1	
	MD2	
Last Write	MD3	most significant byte
	ARCON	start of conversion
First Read	MD0	least significant byte
	MD1	
	MD2	
Last Read	MD3	most significant byte

### Abbreviations

- D'end : Dividend, 1st operand of division
- D'or : Divisor, 2nd operand of division
- M'and : Multiplicand, 1st operand of multiplication
- M'or : Multiplier, 2nd operand of multiplication
- Pr : Product, result of multiplication
- Rem : Remainder
- Quo : Quotient, result of division
- ...L : means, that this byte is the least significant of the 16-bit or 32-bit operand
- ...H : means, that this byte is the most significant of the 16-bit or 32-bit operand

### I/O Ports

The SAB 80C517A has seven 8-bit I/O ports and two input ports (8-bit and 4-bit wide). Port 0 is an open-drain bidirectional I/O port, while ports 1 to 6 are quasi-bidirectional I/O ports

with internal pull-up resistors. That means, when configured as inputs, ports 1 to 6 will be pulled high and will source current when externally pulled low. Port 0 will float when configured as input.

Port 0 and port 2 can be used to expand the program and data memory externally. During an access to external memory, port 0 emits the low-order address byte and reads/writes the data byte, while port 2 emits the high-order address byte. In this function, port 0 is not an open-drain port, but uses a strong internal pull-up FET. Port 1, 3, 4, 5 and port 6 provide several alternate functions. Please see the "Pin Description" for details.

Port pins show the information written to the port latches, when used as general purpose port. When an alternate function is used, the port pin is controlled by the respective peripheral unit. Therefore the port latch must contain a "one" for that function to operate. The same applies when the port pins are used as inputs. Ports 1, 3, 4 and 5 are bit-addressable.

The SAB 80C517A has two dual-purpose input ports. The twelve port lines at port 7 and port 8 can be used as analog inputs for the A/D converter. If input voltages at P7 and P8 meet the specified digital input levels ( $V_{IL}$  and  $V_{IH}$ ) the port can also be used as digital input port.

In Hardware Power Down Mode the port pins and several control lines enter a floating state. For more details see the section about Hardware Power Down Mode.



### Requirements for Hardware Power Down Mode

There is no dedicated pin to enable the Hardware Power Down Mode. Nevertheless for a correct function of the Hardware Power Down Mode the oscillator watchdog unit including its internal RC oscillator is needed. Therefore this unit must be enabled by pin OWE (OWE = high). However, the control pin  $\overline{PE}/\text{SWD}$  has no control function in this mode. It enables and disables only the use of software controlled power saving modes.

### Software controlled power saving modes

All of these modes are entered by software. Special function register PCON (power control register, address is 87<sub>H</sub>) is used to select one of these modes.

### Slow Down Mode

During slow down operation all signal frequencies that are derived from the oscillator clock, are divided by eight, also the clockout signal and the watchdog timer count.

The slow down mode is enabled by setting bit SD. The controller actually enters the slow down mode after a short synchronisation period (max. 2 machine cycles).

The slow down mode is disabled by clearing bit SD.

### Idle Mode

During idle mode all peripherals of the SAB 80C517A (except for the watchdog timer) are still supplied by the oscillator clock. Thus the user has to take care which peripheral should continue to run and which has to be stopped during Idle.

The procedure to enter the idle mode is similar to the one entering the power down mode. The two bits IDLE and IDLS must be set by two consecutive instructions to minimize the chance of unintentional activating of the idle mode.

There are two ways to terminate the idle mode:

- The idle mode can be terminated by activating any enabled interrupt. This interrupt will be serviced and the instruction to be executed following the RETI instruction will be the one following the instruction that set the bit IDLS.
- The other way to terminate the idle mode, is a hardware reset. Since the oscillator is still running, the hardware reset must be held active only for two machine cycles for a complete reset.

Normally the port pins hold the logical state they had at the time idle mode was activated. If some pins are programmed to serve their alternate functions they still continue to output during idle mode if the assigned function is on. The control signals ALE and  $\overline{PSEN}$  hold at logic high levels  $\overline{PSEN}$  (see table 8).



## Power Down Mode

The power down mode is entered by two consecutive instructions directly following each other. The first instruction has to set the flag PDE (power down enable) and must not set PDS (power down set). The following instruction has to set the start bit PDS. Bits PDE and PDS will automatically be cleared after having been set.

The instruction that sets bit PDS is the last instruction executed before going into power down mode. The only exit from power down mode is a hardware reset.

The status of all output lines of the controller can be looked up in table 8.

## Hardware Controlled Power Down Mode

The pin  $\overline{\text{HWPD}}$  controls this mode. If it is on logic high level (inactive) the part is running in the normal operating modes. If pin  $\overline{\text{HWPD}}$  gets active (low level) the part enters the Hardware Power Down Mode; this is independent of the state of pin  $\overline{\text{PE/SWD}}$ .

$\overline{\text{HWPD}}$  is sampled once per machine cycle. If it is found active, the device starts a complete internal reset sequence. The watchdog timer is stopped and its status flag WDTS is cleared exactly the same effects as a hardware reset. In this phase the power consumption is not yet reduced. After completion of the internal reset both oscillators of the chip are disabled. At the same time the port pins and several control lines enter a floating state as shown in table 8. In this state the power consumption is reduced to the power down current IPD. Also the supply voltage can be reduced. Table 8 also lists the voltages which may be applied at the pins during Hardware Power Down Mode without affecting the low power consumption.

Termination of HWPD Mode:

This power down state is maintained while pin  $\overline{\text{HWPD}}$  is held active. If  $\overline{\text{HWPD}}$  goes to high level (inactive state) an automatic start up procedure is performed:

- First the pins leave their floating condition and enter their default reset state (as they had immediately before going to float state).
- Both oscillators are enabled (only if OWE = high). The oscillator watchdog's RC oscillator starts up very fast (typ. less than 2 microseconds)
- Because the oscillator watchdog is active it detects a failure condition if the on-chip oscillator hasn't yet started. Hence, the watchdog keeps the part in reset and supplies the internal clock from the RC oscillator.
- Finally, when the on-chip oscillator has started, the oscillator watchdog releases the part from reset with oscillator watchdog status flag not set. When automatic start of the watchdog was enabled ( $\overline{\text{PE/SWD}}$  connected to  $V_{CC}$ ), the Watchdog Timer will start, too (with its default reload value for time-out period).
- The  $\overline{\text{Reset}}$  pin overrides the Hardware Power Down function, i.e. if reset gets active during Hardware Power Down it is terminated and the device performs the normal reset function. (Thus, pin  $\overline{\text{Reset}}$  has to be inactive during Hardware Power Down Mode).

**Table 8**  
**Status of all pins during Idle Mode, Power Down Mode and Hardware Power Down Mode**

Pins	Idle Mode Last instruction executed from		Power Down Mode Last instruction executed from		Hardware Power Down	
	internal ROM	external ROM	internal ROM	external ROM	Status	Voltage range at pin
P0	Data	float	Data	float		
P1	Data alt outputs	Data alt outputs	Data last outputs	Data last outputs	floating	
P2	Data	Address	Data	Data	output	
P3	Data alt outputs	Data alt outputs	Data last output	Data last output	outputs	
P4	Data alt outputs	Data alt outputs	Data last outputs	Data last output	disabled	$V_{SS} \leq V_{IN} \leq V_{CC}$
P5	Data alt output	Data alt output	Data last output	Data last output	input	
P6	Data alt output	Data alt output	Data last output	Data last output	function	
P7						
P8						
EA					active input	$V_{IN} = V_{CC}$ or $V_{IN} = V_{SS}$
$\overline{PE}/SWD$					active input pull-up disabled	$V_{IN} = V_{CC}$ or $V_{IN} = V_{SS}$
XTAL1					active output	pin may not be driven
XTAL2					disabled input functions	$V_{SS} \leq V_{IN} \leq V_{CC}$

**Table 8**  
**Status of all pins during Idle Mode, Power Down Mode and Hardware Power Down Mode (cont'd)**

Pins	Idle Mode Last instruction executed from		Power Down Mode Last instruction executed from		Hardware Power Down	
	internal ROM	external ROM	internal ROM	external ROM	Status	Voltage range at pin
PSEN					floating outp. dis- abled input functions	$V_{SS} \leq V_{IN} \leq V_{CC}$
ALE						
VAREF VAGND					active sup- ply pins	$V_{AGND} \leq V_{IN} \leq V_{CC}$
OWE					active input, must be high pull-up disabl.	$V_{IN} = V_{CC}$
RESET					active input must be high	$V_{IN} = V_{CC}$
R $\bar{O}$					floating output	$V_{SS} \leq V_{IN} \leq V_{CC}$

## Serial Interfaces

The SAB 80C517A has two serial interfaces. Both interfaces are full duplex and receive buffered. They are functionally identical with the serial interface of the SAB 8051 when working as asynchronous channels. Serial interface 0 additionally has a synchronous mode. Table 9 shows possible configurations and the according baud rates.

**Table 9**  
**Baud Rate Generation**

8-Bit syn-chronous channel	<b>Mode</b>		<b>Mode 0</b>		–	
	Baud-rate	$f_{OSC} = 1$ 2 MHz	1MHz		–	
		$f_{OSC} =$ 16 MHz	1.33 MHz		–	
		$f_{OSC} =$ 18 MHz	1.5 MHz		–	
derived from		$f_{OSC}$			–	
8-Bit UART	<b>Mode</b>		<b>Mode 1</b>		<b>Mode B</b>	
	Baud-rate	$f_{OSC} =$ 12 MHz	1 Baud – 62.5 kBaud		183 Baud – 375 kBaud	366 Baud – 375 kBaud
		$f_{OSC} =$ 16 MHz	1 Baud – 83 kBaud		244 Baud – 500 kBaud	244 Baud – 500 kBaud
		$f_{OSC} =$ 18 MHz	1 Baud – 93.7 kBaud		2375 Baud – 562.5 kBaud	549 Baud – 562.5 kBaud
derived from		Timer 1		10-Bit Baudrate Generator	10-Bit Baudrate Generator	
9-Bit UART	<b>Mode</b>		<b>Mode 2</b>	<b>Mode 3</b>		<b>Mode A</b>
	Baud-rate	$f_{OSC} =$ 12 MHz	187.5 kBaud/ 375 kBaud	1 Baud – 62.5 kBaud	183 Baud – 75 kBaud	183 Baud – 75 kBaud
		$f_{OSC} =$ 16 MHz	250 Baud/ 500 kBaud	1 Baud – 83.3 kBaud	244 Baud – 500 kBaud	244 Baud – 500 kBaud
		$f_{OSC} =$ 18 MHz	281.2 kBaud/ 562.5 kBaud	1 Baud – 93.7 kBaud	275 Baud 562.5 kBaud	549 Baud – 562.5 kBaud
derived from	$f_{OSC}/2$	Timer 1	10-Bit Baudrate Generator		10-Bit Baudrate Generator	

## Serial Interface 0

Serial Interface 0 can operate in 4 modes:

- Mode 0: Shift register mode:  
Serial data enters and exits through R × D0. T × D0 outputs the shift clock 8 data bits are transmitted/received (LSB first). The baud rate is fixed at 1/12 of the oscillator frequency.
- Mode 1: 8-bit UART, variable baud rate:  
10-bit are transmitted (through T × D0) or received (through R × D0): a start bit (0), 8 data bits (LSB first), and a stop bit (1). On reception, the stop bit goes into RB80 in special function register S0CON. The baud rate is variable.
- Mode 2: 9-bit UART, fixed baud rate:  
11-bit are transmitted (through T × D0) or received (through R × D0): a start bit (0), 8 data bits (LSB first), a programmable 9th, and a stop bit (1). On transmission, the 9th data bit (TB80 in S0CON) can be assigned to the value of 0 or 1. For example, the parity bit (P in the PSW) could be moved into TB80 or a second stop bit by setting TB80 to 1. On reception the 9th data bit goes into RB80 in special function register S0CON, while the stop bit is ignored. The baud rate is programmable to either 1/32 or 1/64 of the oscillator frequency.
- Mode 3: 9-bit UART, variable baud rate:  
11-bit are transmitted (through T × D0) or received (through R × D0): a start bit (0), 8 data bits (LSB first), a programmable 9th, and a stop bit (1). In fact, mode 3 is the same as mode 2 in all respects except the baud rate. The baud rate in mode 3 is variable.

## Variable Baud Rates for Serial Interface 0

Variable baud rates for modes 1 and 3 of serial interface 0 can be derived from either timer 1 or a dedicated Baudrate Generator.

The baud rate is generated by a free running 10-bit timer with programmable reload register.

$$\text{Mode 1.3 baud rate} = \frac{2^{\text{SMOD}} * f_{\text{osc}}}{64 * (2^{10} - \text{S0REL})}$$

The default value after reset in the reload registers S0RELL and S0RELH provide a baud rate of 4.8 kBaud (SMOD = 0) or 9.6 kBaud (SMOD = 1) at 12 MHz oscillator frequency. This guarantees full compatibility to the SAB 80C517.

## Serial Interface 1

Serial interface 1 can operate in two asynchronous modes:

Mode A: 9-bit UART, variable baud rate.

11 bits are transmitted (through T × D1) or received (through R × D1): a start bit (0), 8 data bits (LSB first), a programmable 9th, and a stop bit (1). On transmission, the 9th data bit (TB81 in S1CON) can be assigned to the value of 0 or 1. For example, the parity bit (P in the PSW) could be moved into TB81 or a second stop bit by setting TB81 to 1. On reception the 9th data bit goes into RB81 in special function register S1CON, while the stop bit is ignored.

Mode B: 8-bit UART, variable baud rate.

10 bits are transmitted (through T × D1) or received (through R × D1): a start bit (0), 8 data bits (LSB first), and a stop bit (1). On reception, the stop bit goes into RB81 in special function register S1CON.

### Variable Baud Rates for Serial Interface 1.

Variable baud rates for modes A and B of serial interface 1 are derived from a dedicated baud rate generator.

The baud rate clock (baud rate =  $\frac{\text{baud rate clock}}{16}$ ) is generated by an 10-bit free running timer with programmable reload register.

$$\text{Mode A, B baudrate} = \frac{f_{osc}}{32 * (2^{10} - SREL)}$$

**Watchdog Units**

The SAB 80C517A offers two enhanced fail safe mechanisms, which allow an automatic recovery from hardware failure or software upset:

- programmable watchdog timer (WDT), variable from 512  $\mu$ s up to appr. 1.1 s time-out period @12 MHz. Upward compatible to SAB 80515 watchdog.
- oscillator watchdog (OWD), monitors the on-chip oscillator and forces the micro-controller into reset state, in case the on-chip oscillator fails, controls the restart from the Hardware Power Down Mode and provides clock for a fast internal reset after power-on.

**Programmable Watchdog Timer**

The WDT can be activated by hardware or software.

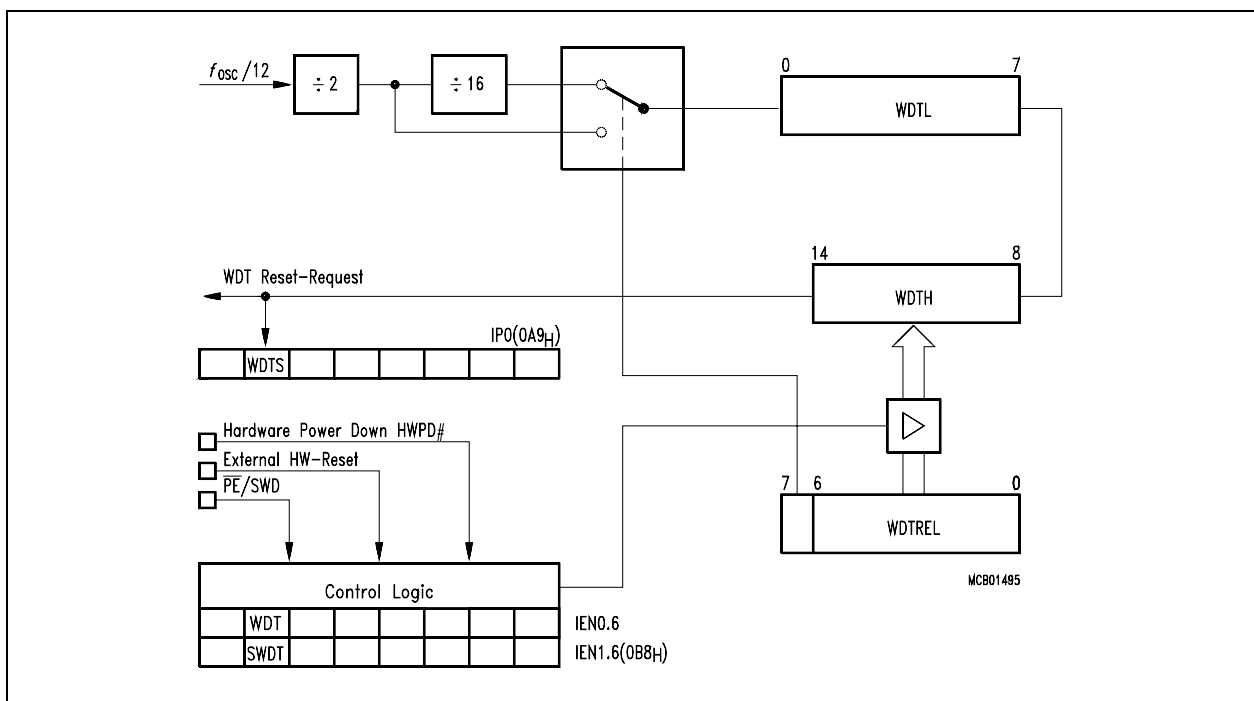
Hardware initialization is done when pin  $\overline{PE}/SWD$  (Pin 4) is held high during RESET. The SAB 80C517A then starts program execution with the WDT running. Since Pin  $\overline{PE}/SWD$  is only sampled during Reset (and hardware power down at parts with stepping code AD and later) dynamical switching of the WDT is not possible.

Software initialization is done by setting bit SWDT.

A refresh of the watchdog timer is done by setting bits WDT and SWDT consecutively.

A block diagram of the watchdog timer is shown in figure 11.

When a watchdog timer reset occurs, the watchdog timer keeps on running, but a status flag WDTS is set. This flag can also be cleared by software.



**Figure 11**  
**Block Diagram of the Programmable Watchdog Timer**

## Oscillator Watchdog

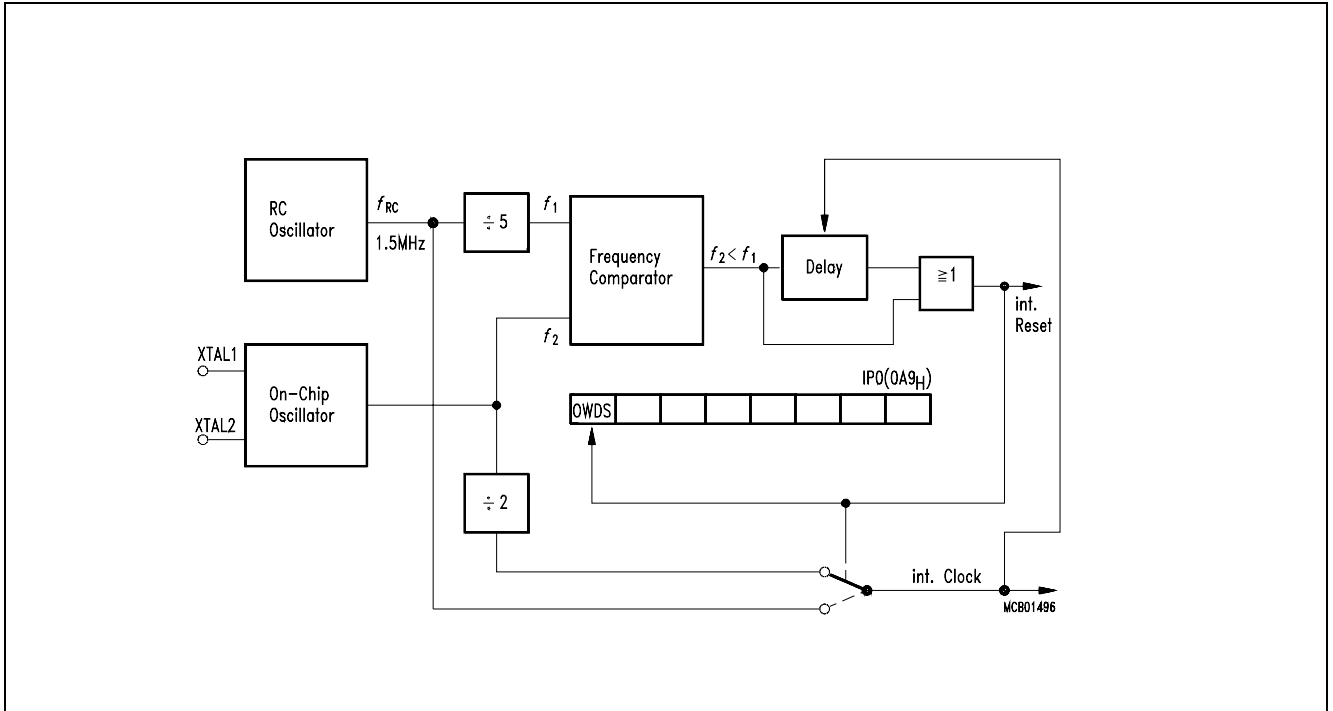
The unit serves three functions:

- Monitoring of the on-chip oscillator's function.  
The watchdog supervises the on-chip oscillator's frequency; if it is lower than the frequency of the auxiliary RC oscillator in the watchdog unit, the internal clock is supplied by the RC oscillator and the device is forced into reset; if the failure condition disappears (i.e. the on-chip oscillator has again a higher frequency than the RC oscillator), the part executes a final reset phase of appr. 0.25 ms in order to allow the oscillator to stabilize; then the oscillator watchdog reset is released and the part starts program execution again.
- Restart from the Hardware Power Down Mode.  
If the Hardware Power Down Mode is terminated the oscillator watchdog has to control the correct start-up of the on-chip oscillator and to restart the program. The oscillator watchdog function is only part of the complete Hardware Power Down sequence; however, the watchdog works identically to the monitoring function.
- Fast internal reset after power-on.  
In this function the oscillator watchdog unit provides a clock supply for the reset before the on-chip oscillator has started. In this case the oscillator watchdog unit also works identically to the monitoring function.

If the oscillator watchdog unit is to be used it must be enabled (this is done by applying high level to the control pin OWE).

Figure 12 shows the block diagram of the oscillator watchdog unit. It consists of an internal RC oscillator which provides the reference frequency of the on-chip oscillator. The RC oscillator can be enabled/disabled by the control pin OWE. If it is disabled the complete unit has no function.





**Figure 12**  
**Functional Block Diagram of the Oscillator Watchdog**

## Fast internal reset after power-on

The SAB 80C517A can use the oscillator watchdog unit for a fast internal reset procedure after power-on.

Normally members of the 8051 family (like the SAB 80C517) enter their default reset state not before the on-chip oscillator starts. The reason is that the external reset signal must be internally synchronized and processed in order to bring the device into the correct reset state. Especially if a crystal is used the start up time of the oscillator is relatively long (typ. 1 ms). During this time period the pins have an undefined state which could have severe effects e.g. to actuators connected to port pins.

In the SAB 80C517A the oscillator watchdog unit avoids this situation. However, the oscillator watchdog must be enabled. In this case, after power-on the oscillator watch-dog's RC oscillator starts working within a very short start-up time (typ. less than 2 micro-seconds). In the following the watchdog circuitry detects a failure condition for the on-chip oscillator because this has not yet started (a failure is always recognized if the watchdog's RC oscillator runs faster than the on-chip oscillator). As long as this condition is valid the watchdog uses the RC oscillator output as clock source for the chip rather than the on-chip oscillator's output. This allows correct resetting of the part and brings also all ports to the defined state.

Delay time between power-on and correct reset state:

Typ.: 18  $\mu$ s

Max.: 34  $\mu$ s

## Instruction Set

The SAB 80C517A / 83C517A-5 has the same instruction set as the industry standard 8051 microcontroller.

A pocket guide is available which contains the complete instruction set in functional and hexadecimal order. Furtheron it provides helpful information about Special Function Registers, Interrupt Vectors and Assembler Directives.

## Literature Information

Title	Ordering No.
Microcontroller Family SAB 8051 Pocket Guide	B158-H6497-X-X-7600

## Absolute Maximum Ratings

Ambient temperature under bias.....	– 40 to 110° C
Storage temperature .....	– 65 to 150 °C
Voltage on $V_{CC}$ pins with respect to ground ( $V_{SS}$ ) .....	– 0.5 V to 6.5 V
Voltage on any pin with respect to ground ( $V_{SS}$ ) .....	– 0.5 to $V_{CC} + 0.5$ V
Input current on any pin during overload condition .....	– 10mA to +10mA
Absolute sum of all input currents during overload condition.....	100mA
Power dissipation .....	1 W

**Note** Stresses above those listed under “Absolute Maximum Ratings” may cause permanent damage of the device. This is a stress rating only and functional operation of the device at these or any other conditions above those indicated in the operational sections of this specification is not implied. Exposure to absolute maximum rating conditions for longer periods may affect device reliability. During overload conditions ( $V_{IN} > V_{CC}$  or  $V_{IN} < V_{SS}$ ) the Voltage on  $V_{CC}$  pins with respect to ground ( $V_{SS}$ ) must not exceed the values defined by the absolute maximum ratings.

## DC Characteristics

$V_{CC} = 5$  V + 10 %, – 15 %;  $V_{SS} = 0$  V

$T_A = 0$  to 70 °C for the SAB 80C517A/83C517A-5

$T_A = -40$  to 85 °C for the SAB 80C517A-T3/83C517A-5-T3

$T_A = -40$  to 110 °C for the SAB 80C517A-T4/83C517A-5-T4

Parameter	Symbol	Limit Values		Unit	Test condition
		min.	max.		
Input low voltage (except $\overline{EA}$ , $\overline{RESET}$ , $\overline{HWPD}$ )	$V_{IL}$	– 0.5	$0.2 V_{CC} - 0.1$	V	–
Input low voltage ( $\overline{EA}$ )	$V_{IL1}$	– 0.5	$0.2 V_{CC} - 0.3$	V	–
Input low voltage ( $\overline{HWPD}$ , $\overline{RESET}$ )	$V_{IL2}$	– 0.5	$0.2 V_{CC} + 0.1$	V	–
Input high voltage (except $\overline{RESET}$ , XTAL2 and $\overline{HWPD}$ )	$V_{IH}$	$0.2 V_{CC} + 0.9$	$V_{CC} + 0.5$	V	–
Input high voltage to XTAL2	$V_{IH1}$	$0.7 V_{CC}$	$V_{CC} + 0.5$	V	–
Input high voltage to $\overline{RESET}$ and $\overline{HWPD}$	$V_{IH2}$	$0.6 V_{CC}$	$V_{CC} + 0.5$	V	–

## DC Characteristics (cont'd)

Parameter	Symbol	Limit Values		Unit	Test condition
		min.	max.		
Output low voltage (ports 1, 2, 3, 4, 5, 6)	$V_{OL}$	–	0.45	V	$I_{OL}=1.6 \text{ mA}^{1)}$
Output low voltage (ports ALE, $\overline{\text{PSEN}}$ , $\overline{\text{RO}}$ )	$V_{OL1}$	–	0.45	V	$I_{OL}=3.2 \text{ mA}^{1)}$
Output high voltage (ports 1, 2, 3, 4, 5, 6)	$V_{OH}$	2.4 $0.9 V_{CC}$	– –	V V	$I_{OH}=-80 \text{ }\mu\text{A}$ $I_{OH}=-10 \text{ }\mu\text{A}$
Output high voltage (port 0 in external bus mode, ALE, $\overline{\text{PSEN}}$ , $\overline{\text{RO}}$ )	$V_{OH1}$	2.4 $0.9 V_{CC}$	– –	V V	$I_{OH}=-800 \text{ }\mu\text{A}^{2)}$ $I_{OH}=-80 \text{ }\mu\text{A}^{2)}$
Logic input low current (ports 1, 2, 3, 4, 5, 6)	$I_{IL}$	– 10	– 70	$\mu\text{A}$	$V_{IN} = 0.45 \text{ V}$
Logical 1-to-0 transition current (ports 1, 2, 3, 4, 5, 6)	$I_{TL}$	– 65	– 650	$\mu\text{A}$	$V_{IN} = 2 \text{ V}$
Input leakage current (port 0, EA, ports 7, 8, $\overline{\text{HWPD}}$ )	$I_{LI}$	–	$\pm 100$	nA	$0.45 < V_{IN} < V_{CC}$
			$\pm 150$	nA	$0.45 < V_{IN} < V_{CC}$ $T_A > 100^\circ\text{C}$
Input low current to $\overline{\text{RESET}}$ for reset	$I_{IL2}$	– 10	–100	$\mu\text{A}$	$V_{IN} = 0.45 \text{ V}$
Input low current (XTAL2)	$I_{IL3}$	–	– 15	$\mu\text{A}$	$V_{IN} = 0.45 \text{ V}$
Input low current ( $\overline{\text{PE}}/\text{SWD}$ , OWE)	$I_{IL4}$	–	– 20	$\mu\text{A}$	$V_{IN} = 0.45 \text{ V}$
Pin capacitance	$C_{IO}$	–	10	pF	$f_C = 1 \text{ MHz}$ $T_A = 25^\circ\text{C}$
Power supply current:					
Active mode, 12 MHz <sup>7)</sup>	$I_{CC}$	–	28	mA	$V_{CC} = 5 \text{ V},^{4)}$
Active mode, 18 MHz <sup>7)</sup>	$I_{CC}$	–	37	mA	$V_{CC} = 5 \text{ V},^{4)}$
Idle mode, 12 MHz <sup>7)</sup>	$I_{CC}$	–	24	mA	$V_{CC} = 5 \text{ V},^{5)}$
Idle mode, 18 MHz <sup>7)</sup>	$I_{CC}$	–	31	mA	$V_{CC} = 5 \text{ V},^{5)}$
Slow down mode, 12 MHz	$I_{CC}$	–	12	mA	$V_{CC} = 5 \text{ V},^{6)}$
Slow down mode, 18 MHz	$I_{CC}$	–	16	mA	$V_{CC} = 5 \text{ V},^{6)}$
Power Down Mode	$I_{PD}$	–	50	$\mu\text{A}$	$V_{CC} = 2 \dots 5.5 \text{ V},^{3)}$

Notes see page 63.

**Notes** for page 62:

- 1) Capacitive loading on ports 0 and 2 may cause spurious noise pulses to be superimposed on the  $V_{OL}$  of ALE and ports 1, 3, 4, 5 and 6. The noise is due to external bus capacitance discharging into the port 0 and port 2 pins when these pins make 1-to-0 transitions during bus operation. In the worst case (capacitive loading > 100 pF), the noise pulse on ALE line may exceed 0.8 V. In such cases it may be desirable to qualify ALE with a schmitt-trigger, or use an address latch with a schmitt-trigger strobe input.
- 2) Capacitive loading on ports 0 and 2 may cause the  $V_{OH}$  on ALE and  $\overline{PSEN}$  to momentarily fall below the 0.9  $V_{CC}$  specification when the address lines are stabilizing.
- 3)  $I_{PD}$  (Power down mode) is measured with:  
 $\overline{EA} = \overline{RESET} = V_{CC}$ ; Port0 = Port7 = Port8 =  $V_{CC}$ ; XTAL1 = N.C.; XTAL2 =  $V_{SS}$ ;  
 $\overline{PE}/\overline{SWD} = OWE = V_{SS}$ ;  $\overline{HWDP} = V_{CC}$  (Software Power Down mode);  $V_{ARef} = V_{CC}$ ;  
 $V_{AGND} = V_{SS}$ ; all other pins are disconnected. Hardware Powerdown  $I_{PD}$ :  $OWE = V_{CC}$   
or  $V_{SS}$ . No certain pin connection for the other pins.
- 4)  $I_{CC}$  (active mode) is measured with:  
XTAL2 driven with  $t_{CLCH}$ ,  $t_{CHCL} = 5$  ns,  $V_{IL} = V_{SS} + 0.5$  V,  $V_{IH} = V_{CC} - 0.5$  V; XTAL1 = N.C.;  
 $\overline{EA} = \overline{PE}/\overline{SWD} = V_{CC}$ ; Port0 = Port7 = Port8 =  $V_{CC}$ ;  $\overline{HWPD} = V_{CC}$ ;  $\overline{RESET} = V_{SS}$   
all other pins are disconnected.  $I_{CC}$  would be slightly higher if a crystal oscillator is  
used (appr. 1 mA).
- 5)  $I_{CC}$  (Idle mode) is measured with all output pins disconnected and with all peripherals disabled; XTAL2 driven with  $t_{CLCH}$ ,  $t_{CHCL} = 5$  ns,  $V_{IL} = V_{SS} + 0.5$  V,  $V_{IH} = V_{CC} - 0.5$  V;  
XTAL1 = N.C.;  $\overline{RESET} = V_{CC}$ ;  $\overline{HWPD} = V_{CC}$ ; Port0 = Port7 = Port8 =  $V_{CC}$  ;  
 $\overline{EA} = \overline{PE}/\overline{SWD} = V_{SS}$ ; all other pins are disconnected;
- 6)  $I_{CC}$  (slow down mode) is measured with all output pins disconnected and with all peripherals disabled; XTAL2 driven with  $t_{CLCH}$ ,  $t_{CHCL} = 5$  ns,  $V_{IL} = V_{SS} + 0.5$  V,  $V_{IH} = V_{CC} - 0.5$  V;  
XTAL1 = N.C.;  $\overline{RESET} = V_{CC}$ ;  $\overline{HWPD} = V_{CC}$ ; Port7 = Port8 =  $V_{CC}$ ;  $\overline{EA} = \overline{PE}/\overline{SWD} = V_{SS}$  ;  
all other pins are disconnected;
- 7)  $I_{CC\ Max}$  at other frequencies is given by:  
active mode:  $I_{CC} (\max) = 1.50 * f_{OSC} + 10$   
idle mode:  $I_{CC} (\max) = 1.17 * f_{OSC} + 10$   
where  $f_{OSC}$  is the oscillator frequency in MHz.  $I_{CC}$  values are given in mA and  
measured at  $V_{CC} = 5$  V.

## A/D Converter Characteristics

$V_{CC} = 5\text{ V} + 10\%, -15\%$ ;  $V_{SS} = 0\text{ V}$

$V_{AREF} = V_{CC} \pm 5\%$ ;  $V_{AGND} = V_{SS} \pm 0.2\text{ V}$ ;

$T_A = 0\text{ to }70\text{ }^\circ\text{C}$  for the SAB 80C517A/83C517A-5

$T_A = -40\text{ to }85\text{ }^\circ\text{C}$  for the SAB 80C517A-T3/83C517A-5-T3

$T_A = -40\text{ to }110\text{ }^\circ\text{C}$  for the SAB 80C517A-T4/83C517A-5-T4

Parameter	Symbol	Limit values			Unit	Test condition
		min.	typ.	max.		
Analog input capacitance	$C_I$		25	70	pF	
Sample time (inc. load time)	$T_S$			$4 t_{CY}^{(1)}$	$\mu\text{s}$	<sup>2)</sup>
Conversion time (inc. sample time)	$T_C$			$14 t_{CY}^{(1)}$	$\mu\text{s}$	<sup>3)</sup>
Total unadjusted error	TUE			$\pm 2$	LSB	$V_{AREF} = V_{CC}$ $V_{AGND} = V_{SS}$
$V_{AREF}$ supply current	$I_{REF}$		$\pm 20$		$\mu\text{A}$	<sup>4)</sup>

<sup>1)</sup>  $t_{CY} = (8 \cdot 2^{ADCL}) / f_{OSC}$ ; ( $t_{CY} = 1 / f_{ADC}$ ;  $f_{ADC} = f_{OSC} / (8 \cdot 2^{ADCL})$ )

<sup>2)</sup> This parameter specifies the time during the input capacitance  $C_I$ , can be charged/discharged by the external source. It must be guaranteed, that the input capacitance  $C_I$ , is fully loaded within this time.  $4TCY$  is  $2\text{ }\mu\text{s}$  at the  $f_{OSC} = 16\text{ MHz}$ . After the end of the sample time  $T_S$ , changes of the analog input voltage have no effect on the conversion result.

<sup>3)</sup> This parameter includes the sample time  $T_S$ .  $14TCY$  is  $7\text{ }\mu\text{s}$  at  $f_{OSC} = 16\text{ MHz}$ .

<sup>4)</sup> The differential impedance  $r_D$  of the analog reference source must be less than  $1\text{ K}\Omega$  at reference supply voltage.

## AC Characteristics

$V_{CC} = 5\text{ V} + 10\%, -15\%$ ;  $V_{SS} = 0\text{ V}$

$T_A = 0\text{ to }70\text{ }^\circ\text{C}$  for the SAB 80C517A/83C517A-5

$T_A = -40\text{ to }85\text{ }^\circ\text{C}$  for the SAB 80C517A-T3/83C517A-5-T3

$T_A = -40\text{ to }110\text{ }^\circ\text{C}$  for the SAB 80C517A-T4/83C517A-5-T4

( $C_L$  for port 0, ALE and  $\overline{\text{PSEN}}$  outputs = 100 pF;  $C_L$  for all other outputs = 80 pF)

Parameter	Symbol	Limit values				Unit
		18 MHz clock		Variable clock $1/t_{CLCL} = 3.5\text{ MHz to }18\text{ MHz}$		
		min.	max.	min.	max.	

## Program Memory Characteristics

ALE pulse width	$t_{LHLL}$	71	–	$2 t_{CLCL} - 40$	–	ns
Address setup to ALE	$t_{AVLL}$	26	–	$t_{CLCL} - 30$	–	ns
Address hold after ALE	$t_{LLAX}$	26	–	$t_{CLCL} - 30$	–	ns
ALE to valid instruction	$t_{LLIV}$	–	122	–	$4t_{CLCL} - 100$	ns
ALE to $\overline{\text{PSEN}}$	$t_{LLPL}$	31	–	$t_{CLCL} - 25$	–	ns
$\overline{\text{PSEN}}$ pulse width	$t_{PLPH}$	132	–	$3 t_{CLCL} - 35$	–	ns
$\overline{\text{PSEN}}$ to valid instruction	$t_{PLIV}$	–	92	–	$3t_{CLCL} - 75$	ns
Input instruction hold after $\overline{\text{PSEN}}$	$t_{PXIX}$	0	–	0	–	ns
Input instruction float after $\overline{\text{PSEN}}$	$t_{PXIZ}$	–	46	–	$t_{CLCL} - 10$	ns
Address valid after $\overline{\text{PSEN}}$	$t_{PXAV^*)}$	48	–	$t_{CLCL} - 8$	–	ns
Address to valid instr in	$t_{AVIV}$	–	218	–	$5t_{CLCL} - 60$	ns
Address float to $\overline{\text{PSEN}}$	$t_{AZPL}$	0	–	0	–	ns

<sup>\*)</sup> Interfacing the SAB 80C51 7A to devices with float times up to 45 ns is permissible. This limited bus contention will not cause any damage to port 0 drivers.

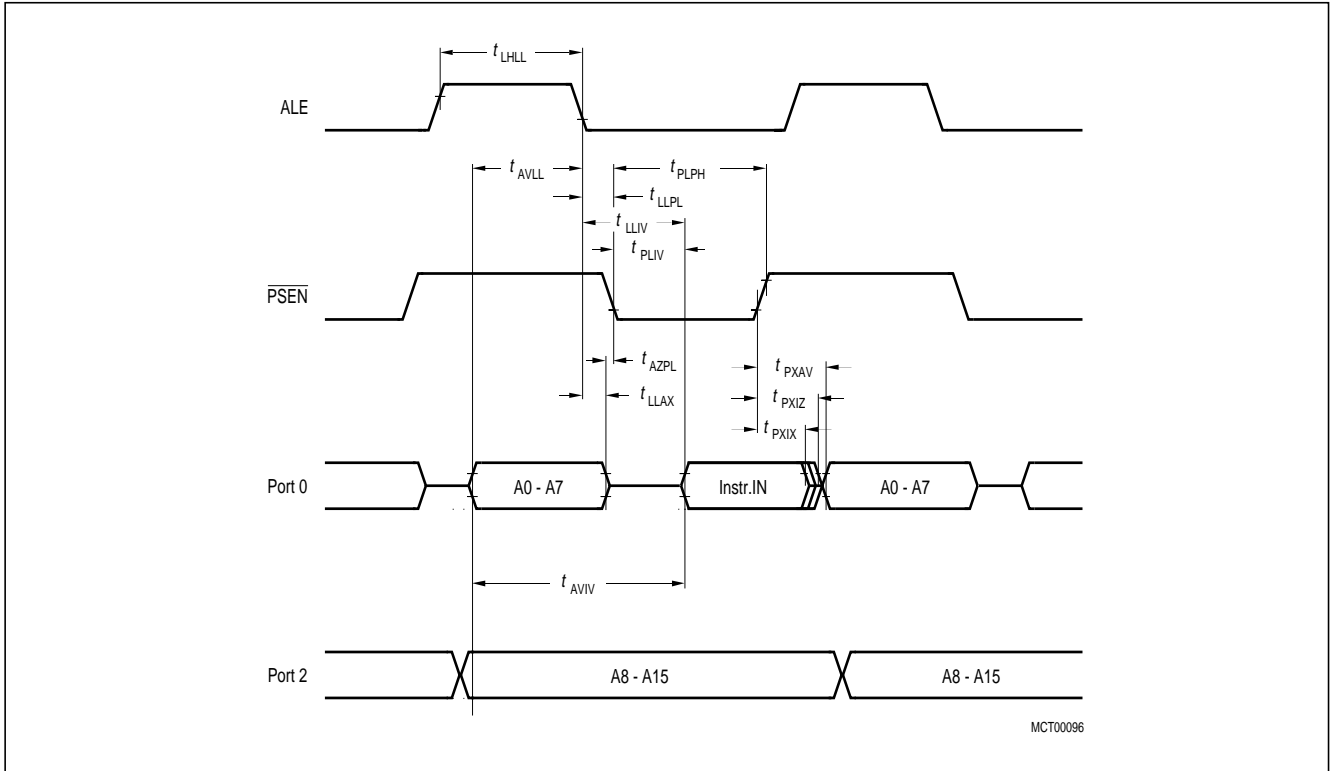
## AC Characteristics (cont'd)

Parameter	Symbol	Limit values				Unit
		18 MHz clock		Variable clock $1/t_{CLCL} = 3.5 \text{ MHz to } 18 \text{ MHz}$		
		min.	max.	min.	max.	

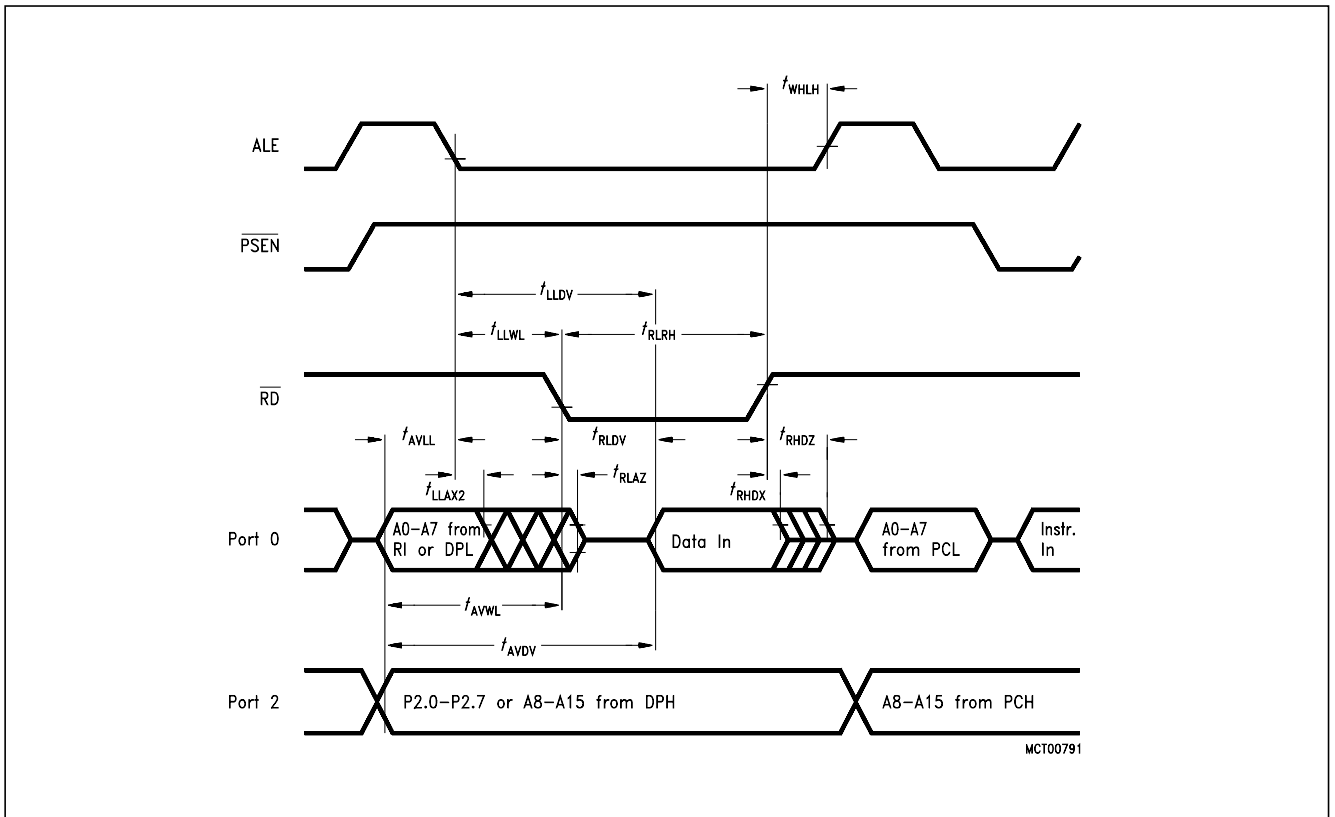
## External Data Memory Characteristics

$\overline{RD}$ pulse width	$t_{RLRH}$	233	–	$6 t_{CLCL} - 100$	–	ns
$\overline{WR}$ pulse width	$t_{WLWH}$	233	–	$6 t_{CLCL} - 100$	–	ns
Address hold after ALE	$t_{LLAX2}$	81	–	$2 t_{CLCL} - 30$	–	ns
$\overline{RD}$ to valid data in	$t_{RLDV}$	–	128	–	$5 t_{CLCL} - 150$	ns
Data hold after $\overline{RD}$	$t_{RHDX}$	0	–	0	–	ns
Data float after $\overline{RD}$	$t_{RHDZ}$	–	51	–	$2 t_{CLCL} - 60$	ns
ALE to valid data in	$t_{LLDV}$	–	294	–	$8 t_{CLCL} - 150$	ns
Address to valid data in	$t_{AVDV}$	–	335	–	$9 t_{CLCL} - 165$	ns
ALE to $\overline{WR}$ or $\overline{RD}$	$t_{LLWL}$	117	217	$3 t_{CLCL} - 50$	$3 t_{CLCL} + 50$	ns
$\overline{WR}$ or $\overline{RD}$ high to ALE high	$t_{WHLH}$	16	96	$t_{CLCL} - 40$	$t_{CLCL} + 40$	ns
Address valid to $\overline{WR}$	$t_{AVWL}$	92	–	$4 t_{CLCL} - 130$	–	ns
Data valid to $\overline{WR}$ transition	$t_{QVWX}$	11	–	$t_{CLCL} - 45$	–	ns
Data setup before $\overline{WR}$	$t_{QVWH}$	239	–	$7 t_{CLCL} - 150$	–	ns
Data hold after $\overline{WR}$	$t_{WHQX}$	16	–	$t_{CLCL} - 40$	–	ns
Address float after $\overline{RD}$	$t_{RLAZ}$	–	0	–	0	ns

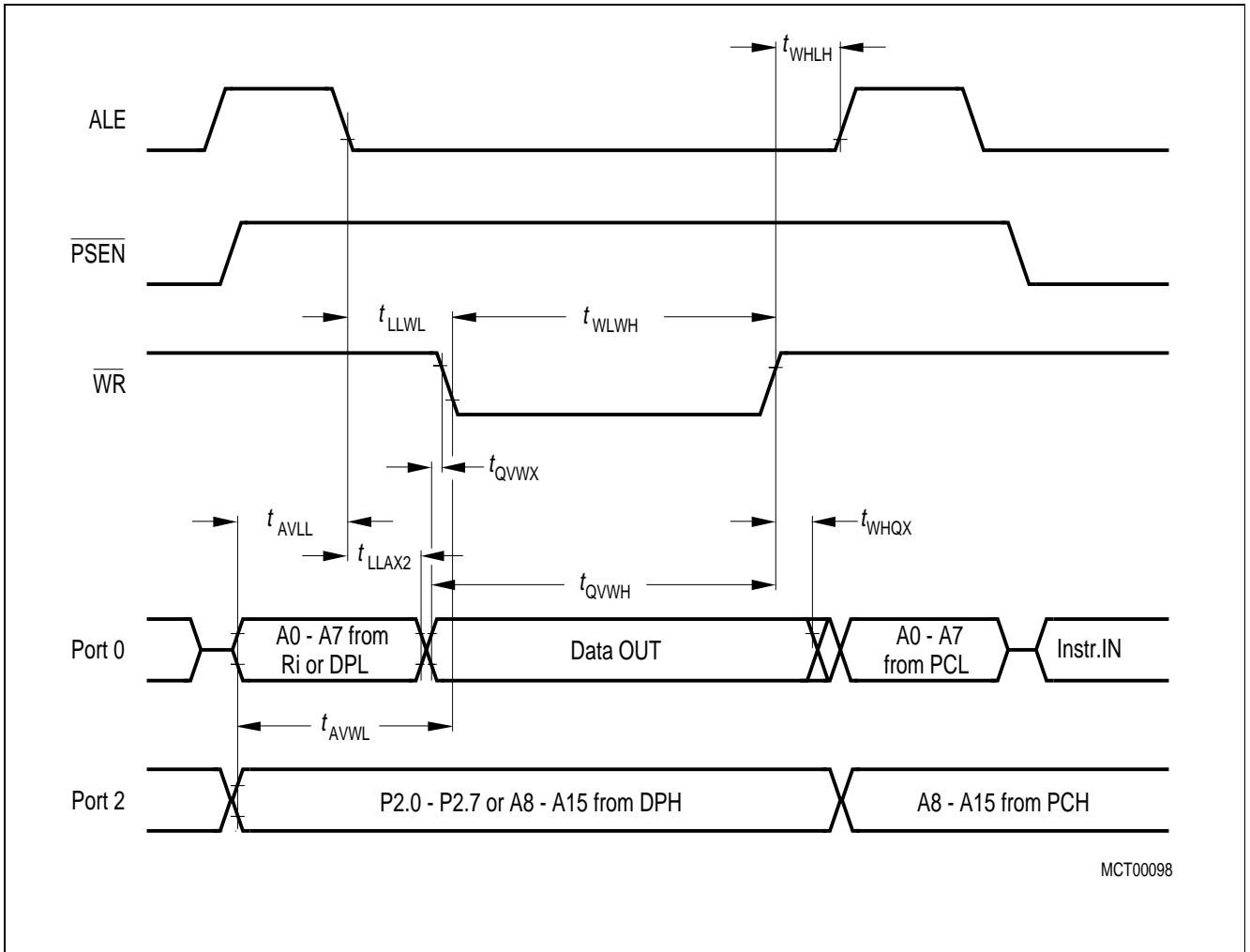




**Program Memory Read Cycle**



**Data Memory Read Cycle**



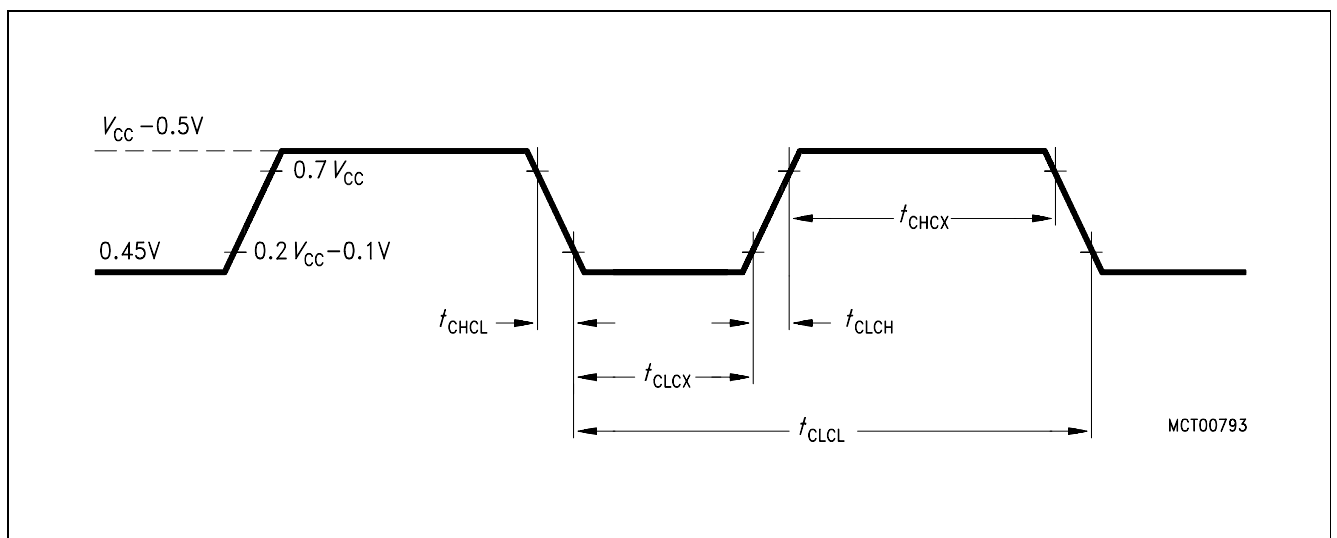
Data Memory Write Cycle

## AC Characteristics (cont'd)

Parameter	Symbol	Limit values		Unit
		Variable clock Frequ. = 3.5 MHz to 18 MHz		
		min.	max.	

## External Clock Drive

Oscillator period	$t_{CLCL}$	55.6	285	ns
High time	$t_{CHCX}$	20	$t_{CLCL} - t_{CHCX}$	ns
Low time	$t_{CLCX}$	20	$t_{CLCL} - t_{CHCX}$	ns
Rise time	$t_{CLCH}$	–	20	ns
Fall time	$t_{CHCL}$	–	20	ns
Oscillator frequency	$1/t_{CLC}$	3.5	18	MHz



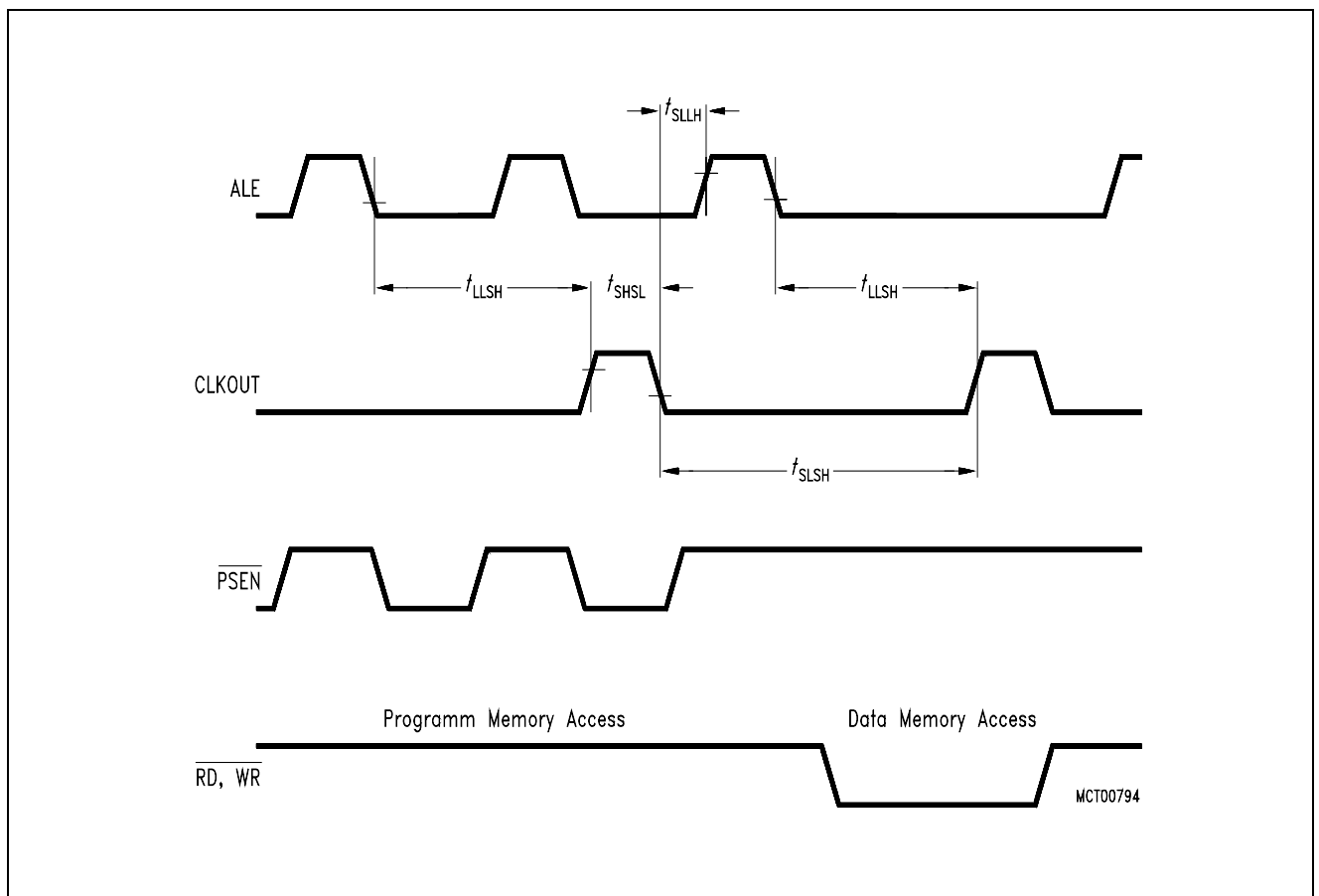
## External Clock Cycle

## AC Characteristics (cont'd)

Parameter	Symbol	Limit values				Unit
		18 MHz clock		Variable clock $1/t_{CLCL} = 3.5 \text{ MHz to } 18 \text{ MHz}$		
		min.	max.	min.	max.	

## System Clock Timing

ALE to CLKOUT	$t_{LLSH}$	349	–	$7 t_{CLCL} - 40$	–	ns
CLKOUT high time	$t_{SHSL}$	71	–	$2 t_{CLCL} - 40$	–	ns
CLKOUT low time	$t_{SLSH}$	516	–	$10 t_{CLCL} - 40$	–	ns
CLKOUT low to ALE high	$t_{SLLH}$	16	96	$t_{CLCL} - 40$	$t_{CLCL} + 40$	ns



## System Clock Timing

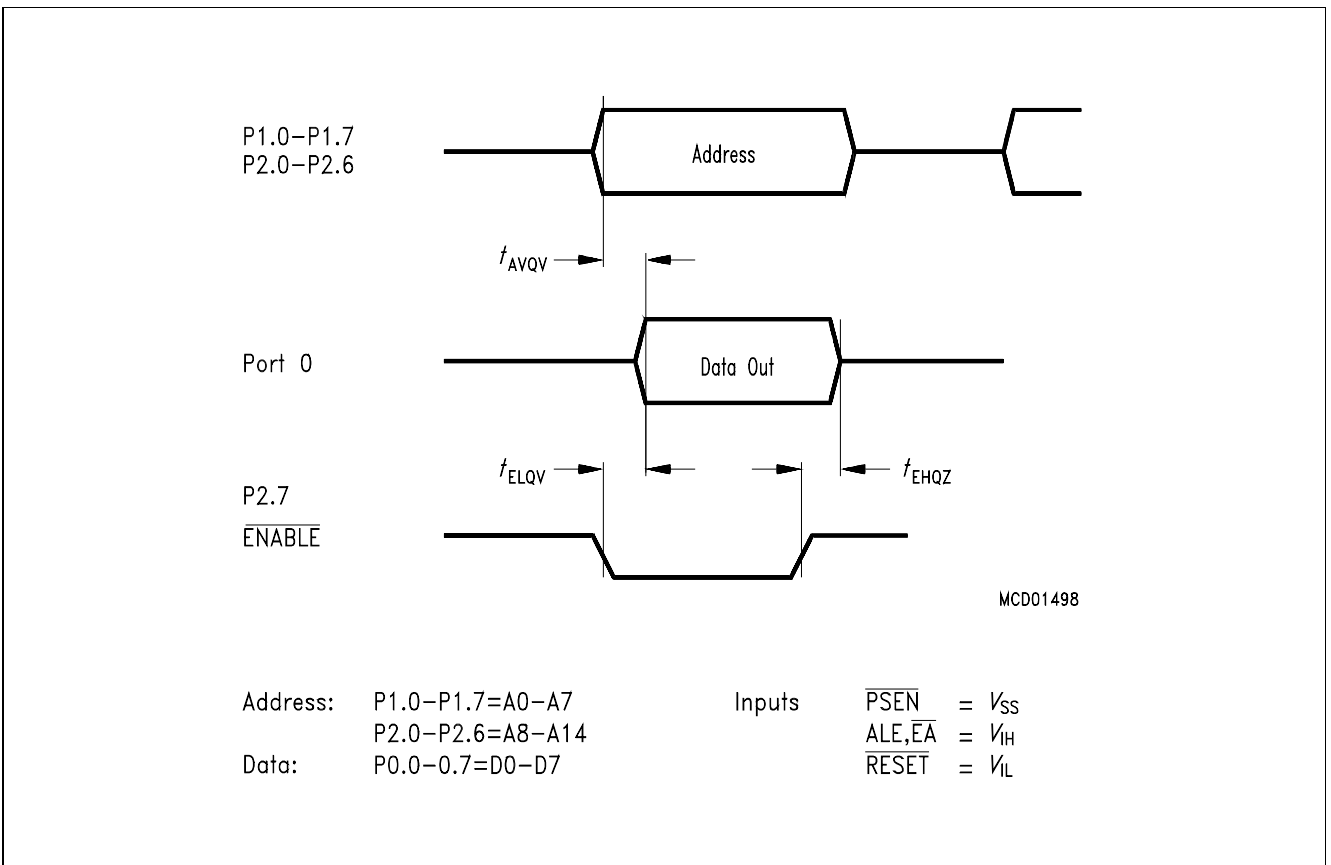
**ROM Verification Characteristics**

$T_A = 25^\circ\text{C} \pm 5^\circ\text{C}$ ;  $V_{CC} = 5\text{ V} \pm 10\%$ ;  $V_{SS} = 0\text{ V}$

Parameter	Symbol	Limit values		Unit
		min.	max.	

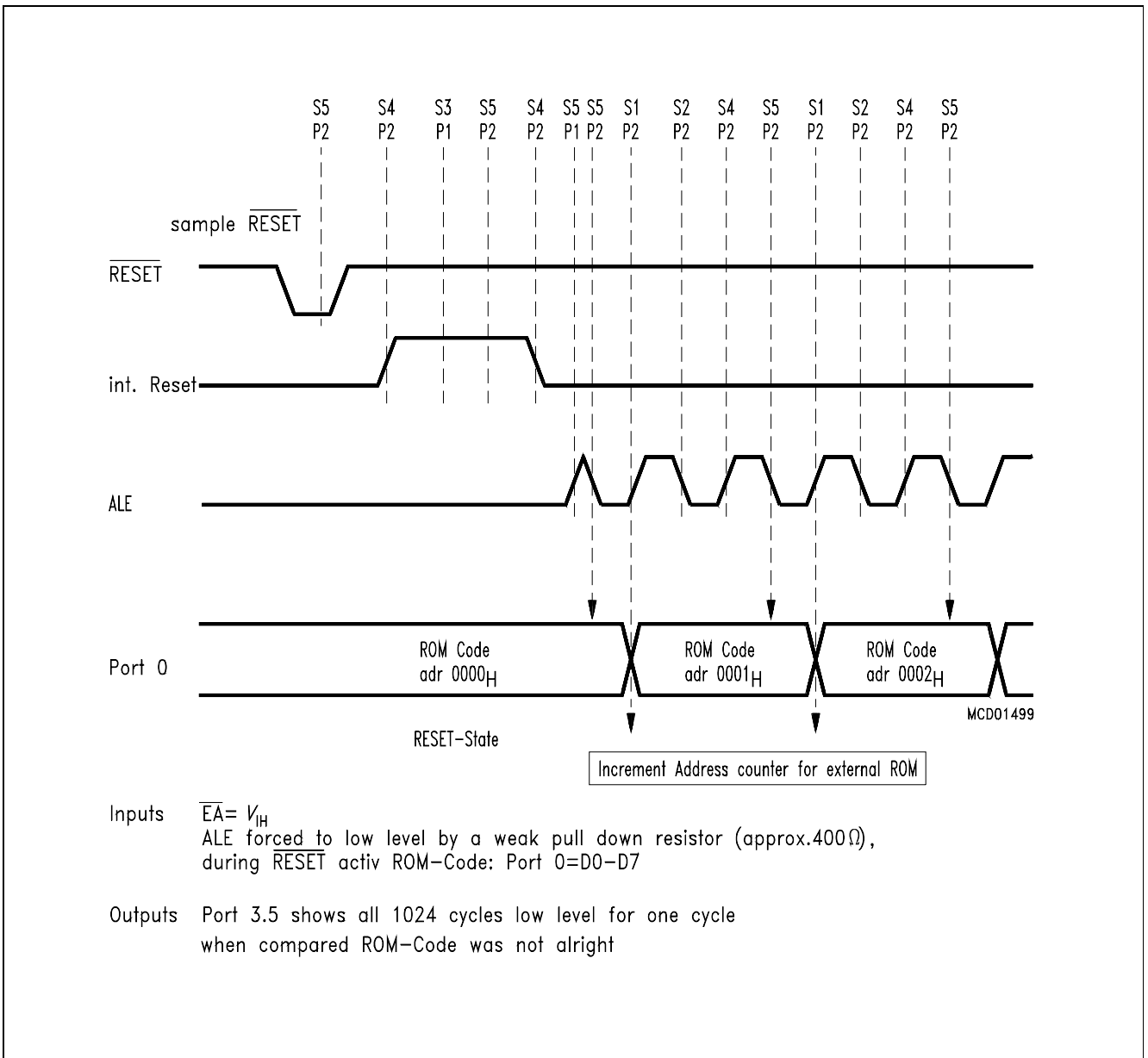
**ROM Verification Mode 1 (Standard Verify Mode for not Read Protected ROM)**

Address to valid data	$t_{AVQV}$	–	$48 t_{CLCL}$	ns
ENABLE to valid data	$t_{ELQV}$	–	$48 t_{CLCL}$	ns
Data float after ENABLE	$t_{EHOZ}$	0	$48 t_{CLCL}$	ns
Oscillator frequency	$1/t_{CLCL}$	4	6	MHz

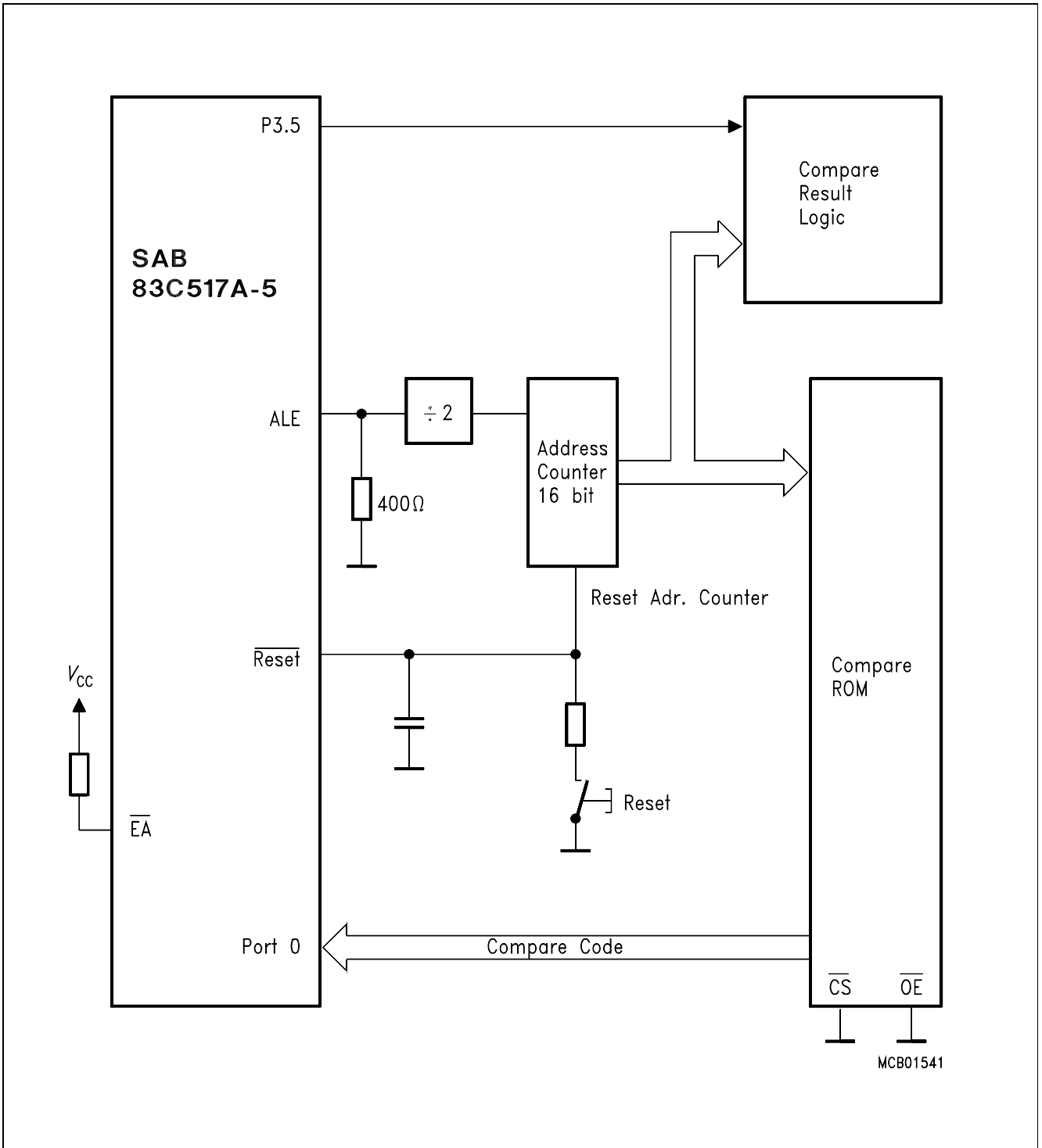


**ROM Verification Mode 1**

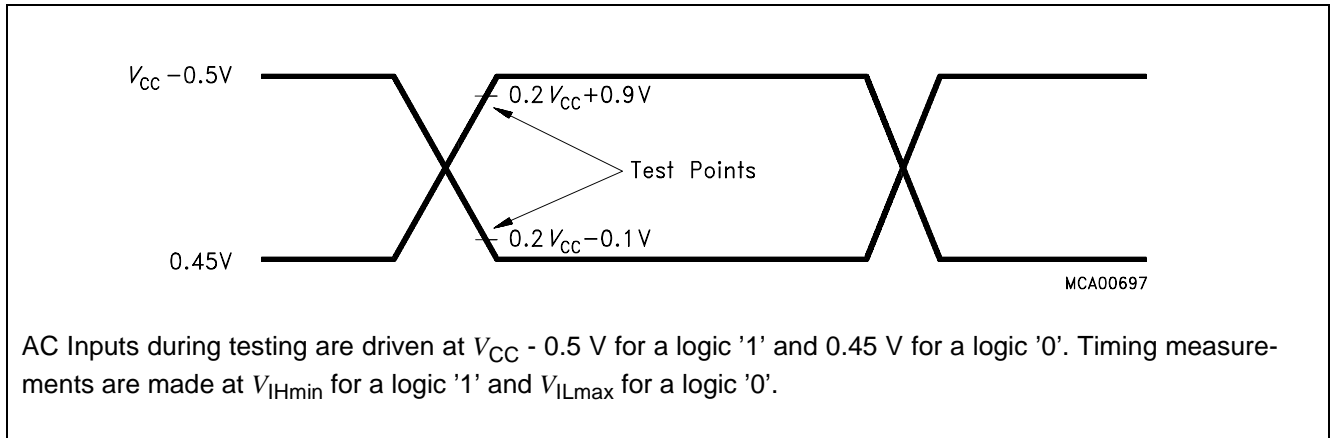
**ROM Verification Mode 2 (New Verify Mode for Protected and not Protected ROM)**



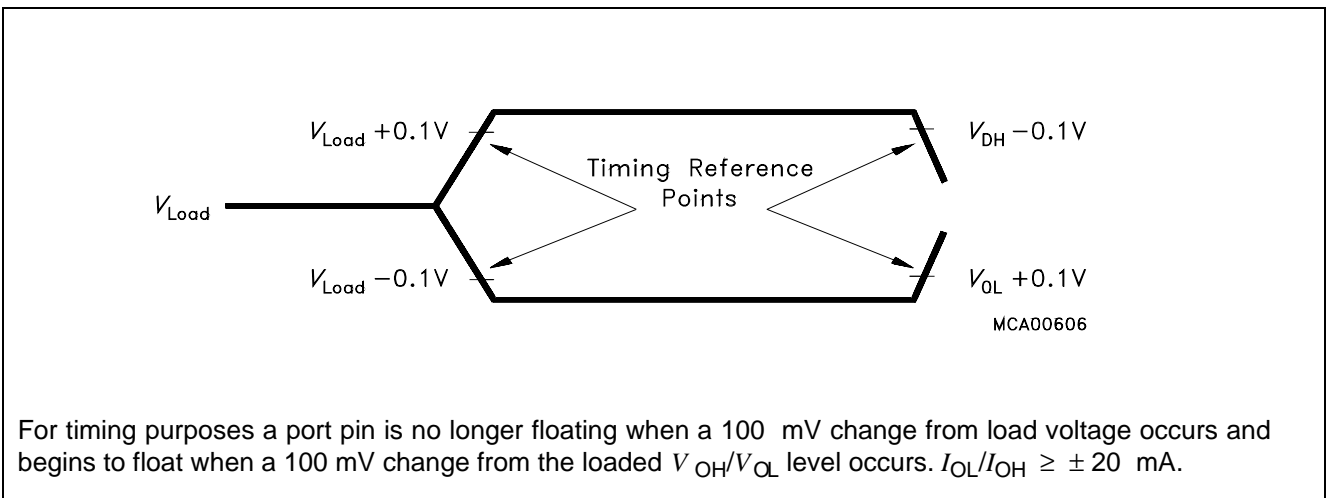
**ROM Verification Mode 2**



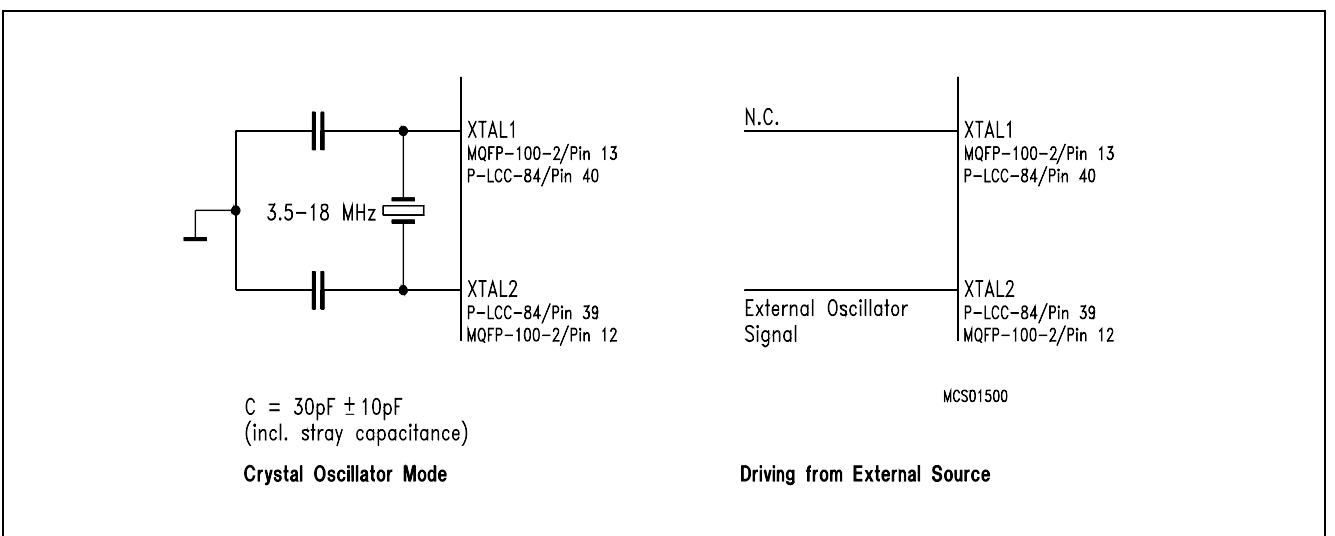
**Application Circuitry for Verifying the Internal ROM**



**AC Testing: Input, Output Waveforms**



**AC Testing: Float Waveforms**



**Recommended Oscillator Circuits**



