

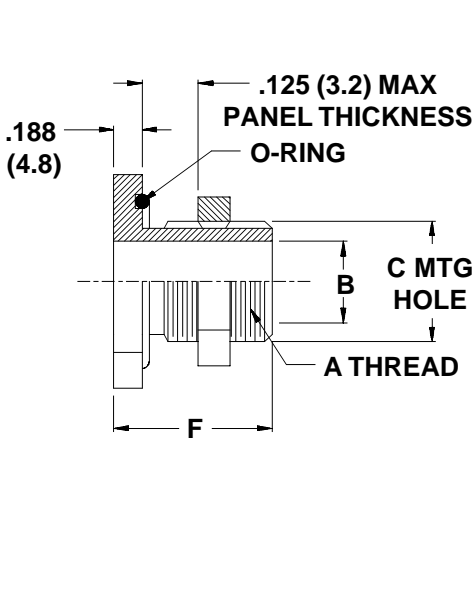

710-100 Metal Bulkhead Adapters & Feed-Throughs for Series 72 & 74 Tubing and Series 75 Conduit

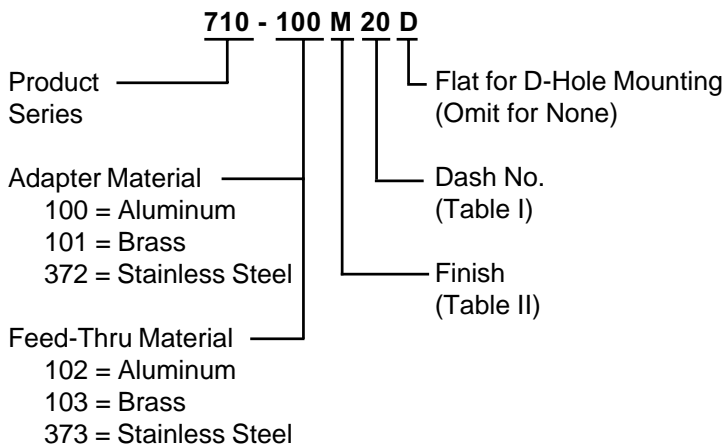

Bulkhead Adapters
710-100/101/372

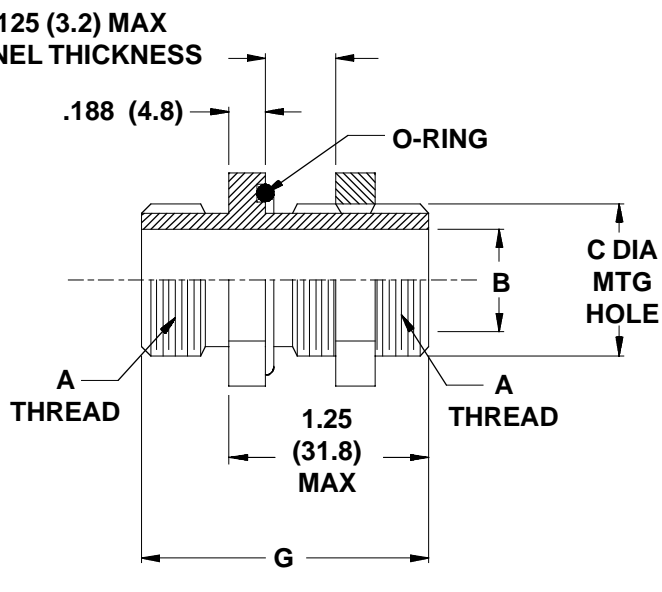
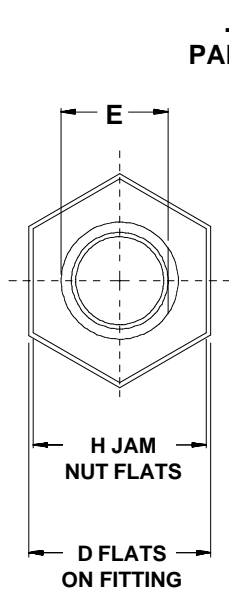

Bulkhead Feed-Throughs
710-102/103/373

Metric dimensions (mm) are in parentheses.

710-100 Metal Bulkhead Adapters & Feed-Throughs for Series 72 & 74 Tubing and Series 75 Conduit



TABLE I

DASH NO.	AVAILABILITY			A THREAD CLASS 2A	B DIA ±.015 (.4)	C DIA		D FITTING	E		F MAX	G MAX	H JAM NUT
	72	74	75			+ .03 (.8)	- .00 (.0)		+ .0 (.0)	- .015 (.4)			
06		06		7/16 - 28 UNEF	.193 (4.9)	.44 (11.2)	.69 (17.5)	.375 (9.5)	1.00 (25.4)	1.63 (41.4)	.63 (16.0)		
08			08	1/2 - 20 UNF	.255 (6.5)	.50 (12.7)	.75 (19.1)	.438 (11.1)	1.00 (25.4)	1.63 (41.4)	.75 (19.1)		
09	09	09		9/16 - 24 UNEF	.286 (7.3)	.56 (14.2)	.81 (20.6)	.500 (12.7)	1.00 (25.4)	1.63 (41.4)	.75 (19.1)		
10		10		9/16 - 24 UNEF	.317 (8.1)	.56 (14.2)	.81 (20.6)	.500 (12.7)	1.00 (25.4)	1.63 (41.4)	.75 (19.1)		
12	12	12	12	5/8 - 24 UNEF	.380 (9.7)	.63 (16.0)	.88 (22.4)	.563 (14.3)	1.00 (25.4)	1.63 (41.4)	.81 (20.6)		
14		14		11/16 - 24 UNEF	.442 (11.2)	.69 (17.5)	.94 (23.9)	.625 (15.9)	1.00 (25.4)	1.63 (41.4)	.88 (22.4)		
16	16	16	16	3/4 - 20 UNEF	.505 (12.8)	.75 (19.1)	1.00 (25.4)	.688 (17.5)	1.00 (25.4)	1.63 (41.4)	.94 (23.9)		
20	20	20	20	7/8 - 20 UNEF	.630 (16.0)	.88 (22.4)	1.13 (28.7)	.812 (20.6)	1.00 (25.4)	1.63 (41.4)	1.06 (26.9)		
24	24	24	24	1 - 20 UNEF	.755 (19.2)	1.00 (25.4)	1.25 (31.8)	.938 (23.8)	1.00 (25.4)	1.63 (41.4)	1.25 (31.8)		
28	28	28		1 3/16 - 18 UNEF	.880 (22.4)	1.19 (30.2)	1.44 (36.6)	1.125 (28.6)	1.00 (25.4)	1.63 (41.4)	1.38 (35.1)		
32	32	32	32	1 5/16 - 18 UNEF	1.005 (25.5)	1.31 (33.3)	1.56 (39.6)	1.250 (31.8)	1.00 (25.4)	1.63 (41.4)	1.62 (41.1)		
40	40	40	40	1 1/2 - 18 UNEF	1.255 (31.9)	1.50 (38.1)	1.81 (46.0)	1.438 (36.5)	1.00 (25.4)	1.63 (41.4)	1.75 (44.5)		
48	48	48	48	1 3/4 - 18 UNS	1.505 (38.2)	1.75 (44.5)	2.06 (52.3)	1.688 (42.9)	1.13 (28.7)	1.75 (44.5)	2.00 (50.8)		
56		56	56	2 - 18 UNS	1.755 (44.6)	2.00 (50.8)	2.31 (58.7)	1.938 (49.2)	1.13 (28.7)	1.75 (44.5)	2.19 (55.6)		
64		64	64	2 1/4 - 16 UN	2.005 (50.9)	2.25 (57.2)	2.56 (65.0)	2.188 (55.6)	1.13 (28.7)	1.75 (44.5)	2.44 (62.0)		
80			80	2 3/4 - 16 UN	2.505 (63.6)	2.75 (69.9)	3.06 (77.7)	2.688 (68.3)	1.13 (28.7)	1.75 (44.5)	3.00 (76.2)		
96			96	3 1/4 - 16 UN	3.005 (76.3)	3.25 (82.6)	3.56 (90.4)	3.188 (81.0)	1.13 (28.7)	1.75 (44.5)	3.50 (88.9)		

TABLE II

SYMBOL	FINISH
B	Olive Drab over Cadmium Plate
J	Gold Iridite over Cadmium Plate over Nickel
M	Electroless Nickel
N	Olive Drab over Cadmium Plate over Nickel
NC	Zinc-Cobalt, Olive Drab
NF	Olive Drab over Cadmium Plate over Electroless Nickel (500 Hour Salt Spray)
T	Bright Dip Cadmium Plate over Nickel
Z1	Passivate

Metric dimensions (mm) are in parentheses.