

IQF-25L Series

I&Q NETWORKS

1.5 to 3 GHz / 10 % Bandwidth / In-Circuit, Voltage Controlled Phase Balance / Hi-Rel Hermetic Pkg

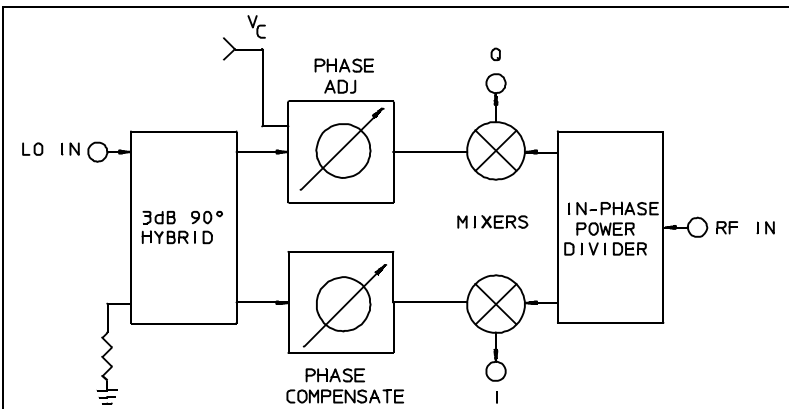
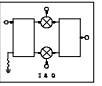

PRINCIPAL SPECIFICATIONS

Model Number	LO Frequency, f_0 , MHz	Bandwidth RF Input
IQF-25L-***B	1500 - 3000	10% of f_0

For complete Model Number replace *** with desired LO Frequency in MHz.

GENERAL SPECIFICATIONS

RF and LO Input Characteristics

Impedance:	50 Ω nom.
VSWR:	1.5:1 max.
RF Power Level:	0 dBm nom.
LO Power Level:	+10 dBm nom.

I & Q Output Characteristics

Video Bandwidth, nom:	DC to \dagger 100 MHz
Output Impedance:	50 Ω nom.
Conversion Loss (RF to I or Q):	10 dB typ., 12 dB max.

IF Balance (I to Q)

Phase, @ $V_c=+5V$:	$90^\circ \pm 5^\circ$
Bias Control:	0 to +15V
Phase Tuning Range:	$\pm 10^\circ$ nom., @ f_0
Tuning Sensitivity:	$4^\circ/V$ nom.
Temperature Stability:	$\pm 1^\circ$ nom., $\pm 2^\circ$ max.
Amplitude:	0.2 dB max.
Weight, nominal	0.55 oz (15.4 g)
Operating Temp:	-55° to $+85^\circ C$

\dagger RF and Video Bandwidths are typically much greater than specified.

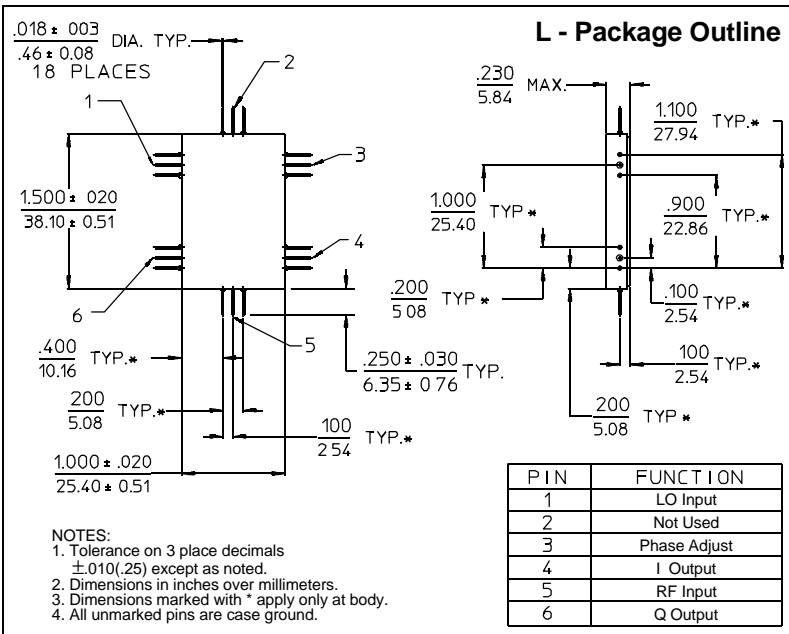

General Notes:

1. I & Q networks are integrated devices that produce two quadrature-phased, equal amplitude signals when fed RF and LO signals.
2. The IQF-25L series features an in-circuit, voltage controlled phase balance that allows fine adjustment of phase. This feature provides accuracy not previously attainable in a comparably small package. In addition, the voltage controlled phase balance input facilitates closed loop, servo operation using the phase adjustment input as feedback.
3. Merrimac I & Q networks comply with the relevant sections of MIL-M-28837 and may be supplied screened for compliance with additional specifications for military and space applications requiring the highest reliability.

24May96