

REV A	AUTH RL	DATE 7/17/02	INITIAL RELEASE
REV B	AUTH JLE	DATE 1/13/03	WR102 DIM 'C' 1.14 WAS: 1.15; DIM 'B' IS: .164, WAS: .165
REV C	AUTH RL	DATE 8/11/03	ADDED WR650 TABLE DIMENSIONS
REV D	AUTH RL	DATE 09/09/05	REVISED TABLE DIMS FOR WR62, WR75, WR90
REV E	AUTH RL	DATE 04/03/06	DIMS REVISED PER ECN 04-03-06-01

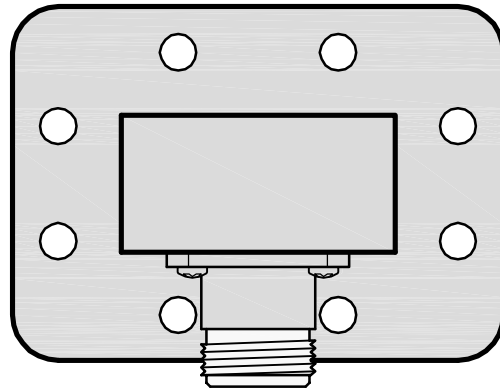

FLANGE AS REQUESTED (CPRF SHOWN)

TYPE-N (F) CONN.
5/8-24 UNEF-2A THD.

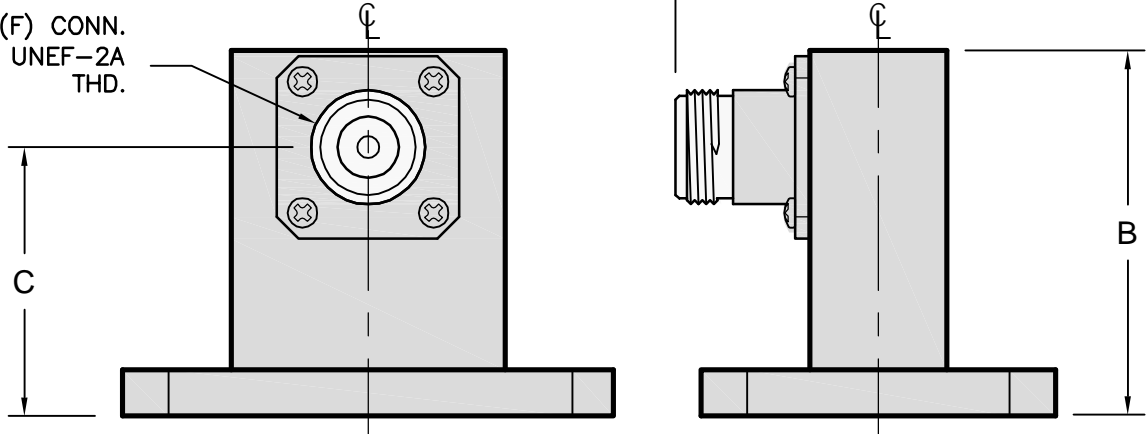

WG SIZE	DIMENSION (INCHES)		
	A	B	C
WR62	1.08	1.00	0.65
WR75	1.09	1.00	0.63
WR90	1.10	1.00	0.63
WR102	1.18	1.64	1.14
WR112	1.05	1.14	0.67
WR137	1.11	2.00	1.47
WR159	1.20	2.33	1.70
WR187	1.24	2.60	1.90
WR229	1.37	2.25	1.35
WR284	1.49	2.50	1.51
WR340	1.67	3.50	2.29
WR430	1.89	4.00	2.30
WR650	2.44	5.00	2.40

THIRD ANGLE PROJECTION:	APPROVALS	DATE		ADVANCED TECHNICAL MATERIALS, INC. TEL: (631) 289-0363 FAX: (631) 289-0358 www.atmmicrowave.com		THE INFORMATION IN THIS DRAWING IS PROPRIETARY AND SHALL NOT BE USED OR DISCLOSED WITHOUT THE PRIOR WRITTEN CONSENT OF ATM, INC. DO NOT SCALE DWG.
UNLESS OTHERWISE NOTED, DIMENSIONS ARE IN INCHES. TOLERANCES ARE: FRACTIONS: ±1/64 ANGLES: ±1/2°	DRAWN RL	04/03/06		www.atmmicrowave.com		
BASIC DIMENSION UNDER 6" ±.02	6" - 12" ±.03	OVER 12" ±.06	DECIMALS 2 PLACE ±.005	3 PLACE ±.010	APRVD.	
MATERIAL PER ORDER			TREATMENT -		FINISH ATM GRAY	
SIZE A		CAGE CODE OR8N4	ATM DWG # 5038W		REVISION E	
SCALE NONE		MODEL # XXX-253X-XX			SHEET 1/1	

OUTLINE, W/G-COAX
ADAPTER TYPE-N