

PART NUMBER 142-0761-861	ITEM ① BODY BRASS GOLD PL .00001 MIN OVER NICKEL PL .0001 MIN OVER COPPER PL .00005 MIN	ITEM ② CONTACT BERYLLIUM COPPER GOLD PL .00005 MIN OVER NICKEL PL .00005 MIN OVER COPPER PL .00005 MIN	ITEM ③ INSULATOR TEFLON
-----------------------------	--	---	-------------------------------

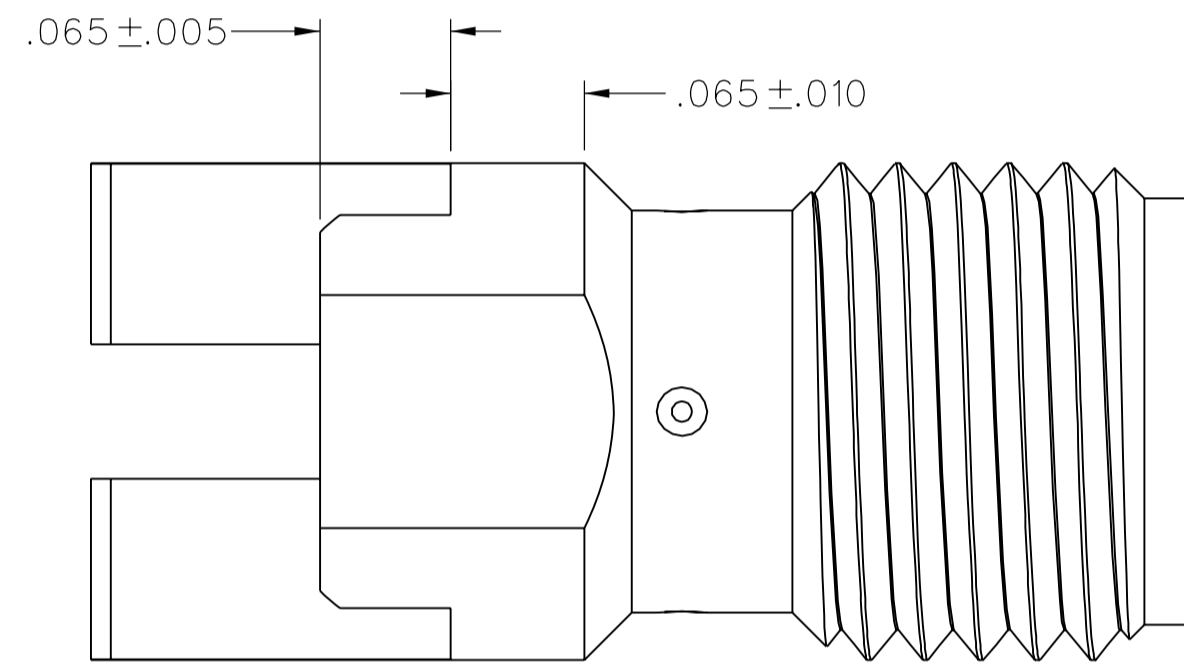
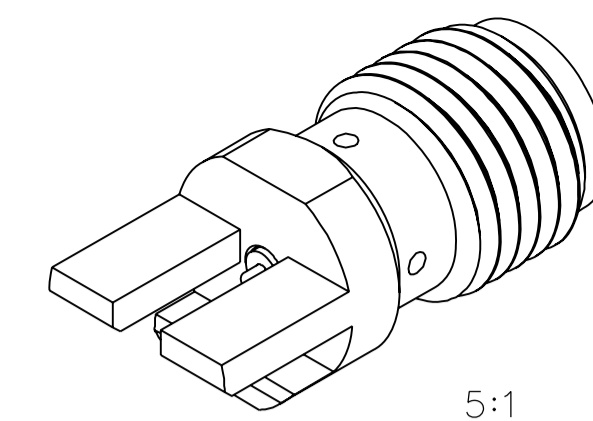
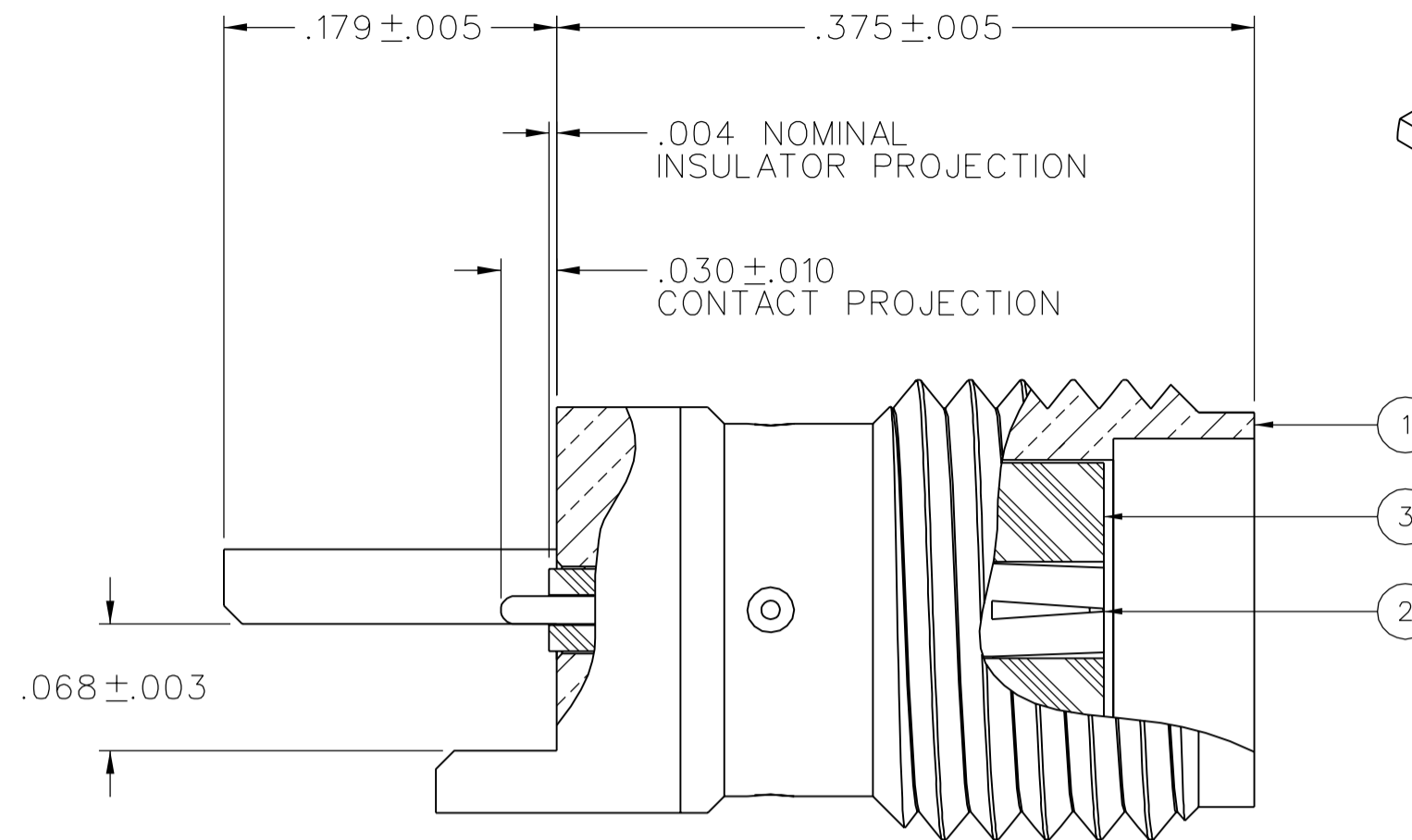
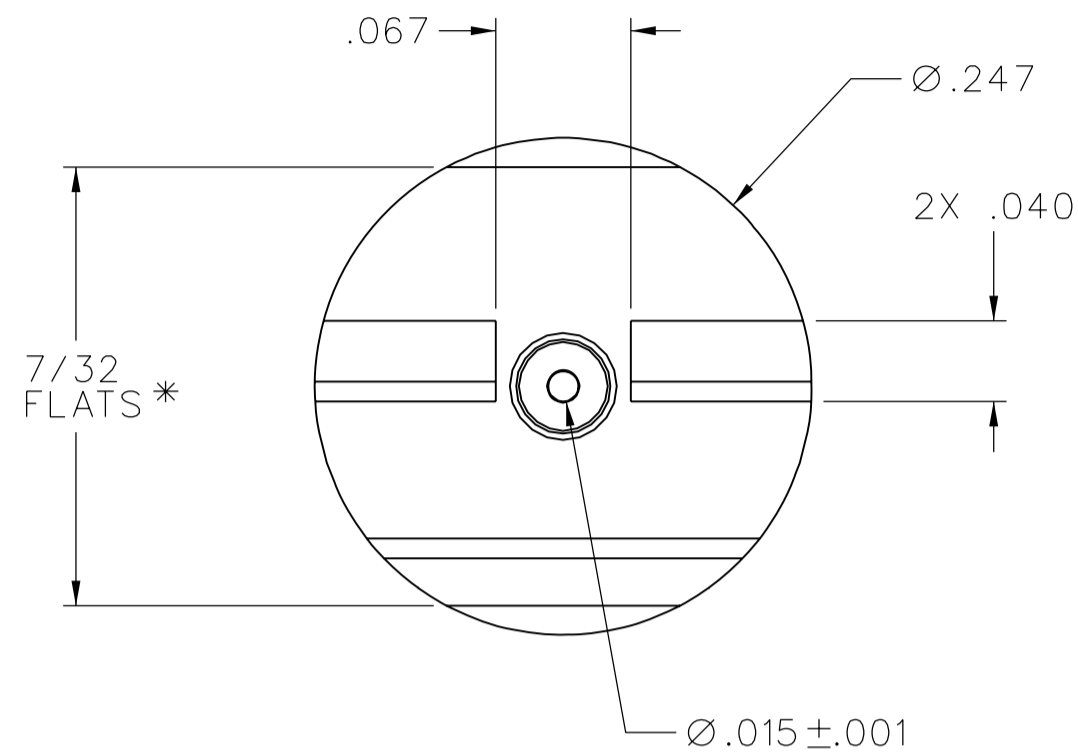

NOTES:

1. SPECIFICATIONS:

IMPEDANCE: 50 OHMS
 FREQUENCY RANGE: 0-26.5 GHz
 VSWR: 1.05+.02F(GHz) MAX AT 0-18 GHz, TYPICALLY < 1.50 AT 18-26.5 GHz
 WORKING VOLTAGE: 170 VRMS MAX AT SEA LEVEL
 DIELECTRIC WITHSTANDING VOLTAGE: 500 VRMS MIN AT SEA LEVEL
 INSULATION RESISTANCE: 1000 MEGOHM MIN
 CONTACT RESISTANCE:
 CENTER CONTACT - INITIAL 3.0 MILLIOHM MAX, AFTER ENVIRONMENTAL 4.0 MILLIOHM MAX
 OUTER CONDUCTOR - INITIAL 2.0 MILLIOHM MAX AFTER ENVIRONMENTAL NOT APPLICABLE
 CORONA LEVEL: 125 VOLTS MIN AT 70,000 FEET
 INSERTION LOSS: NOT APPLICABLE (DEPENDANT UPON APPLICATION)
 RF LEAKAGE: NOT APPLICABLE
 RF HIGH POTENTIAL WITHSTANDING VOLTAGE: 335 VRMS MIN AT 4 AND 7 MHz

MECHANICAL:

ENGAGE/DISENGAGE TORQUE: 2 INCH-POUNDS MAX
 MATING TORQUE: 7-10 INCH POUNDS WHEN BODY SUPPORTED WITH WRENCH
 *8 INCH POUNDS MAX UNSUPPORTED
 CONTACT RETENTION: 6 LBS MIN AXIAL FORCE ON MATING END
 4 IN-OZ MIN RADIAL TORQUE
 DURABILITY: 500 CYCLES MIN

ENVIRONMENTAL:

(MEETS OR EXCEEDS THE APPLICABLE PARAGRAPH OF MIL-PRF-39012)
 THERMAL SHOCK: MIL-STD-202, METHOD 107, CONDITION B, EXCEPT 115°C HIGH TEMP
 OPERATING TEMPERATURE: -65 DEG C TO 165 DEG C
 CORROSION: MIL-STD-202, METHOD 101, CONDITION B
 SHOCK: MIL-STD-202, METHOD 213, CONDITION I
 VIBRATION: MIL-STD-202, METHOD 204, CONDITION D
 MOISTURE RESISTANCE: MIL-STD-202, METHOD 106

② ALL HOLES PLATED THRU ENTIRE CIRCUIT BOARD STACKUP.

③ HOLE PATTERNS SYMMETRICAL ABOUT CENTER OF CPW TRACE.

4. FOR OPTIMUM CIRCUIT BOARD HIGH FREQUENCY PERFORMANCE:
 A. MAINTAIN SOLID GROUND PLANE BELOW HF SUBSTRATE.
 B. CONTROL PULLBACK OF TRACE AND GROUND FROM BOARD EDGE.
 C. CONTINUE GROUNDED COPLANAR LINE BEYOND GROUND PADS.
 D. PLACE 16 MIL DIA GROUND VIAS ON BOTH SIDES OF COPLANAR WAVEGUIDE LINE AT 50 MIL INTERVALS ALONG ENTIRE LENGTH.
 E. IMMERSION GOLD PLATE (ENIG) ALL CONDUCTORS PER IPC-4552.

⑤ REFERENCE DIMENSIONS FOR 50 OHM GROUNDED CPW LINE, USING ROGERS RO4003, 16 MIL HIGH FREQUENCY CIRCUIT BOARD SUBSTRATE:
 TRACE WIDTH = 28.5 MILS
 GROUND GAPS = 10 MILS
 CONDUCTOR THICKNESS = 1.4 MIL (INCLUDES PLATING)

6. EMERSON NETWORK POWER CONNECTIVITY SOLUTIONS HIGH FREQUENCY END LAUNCH CONNECTORS ARE COVERED UNDER US PATENT NUMBER 7,344,381

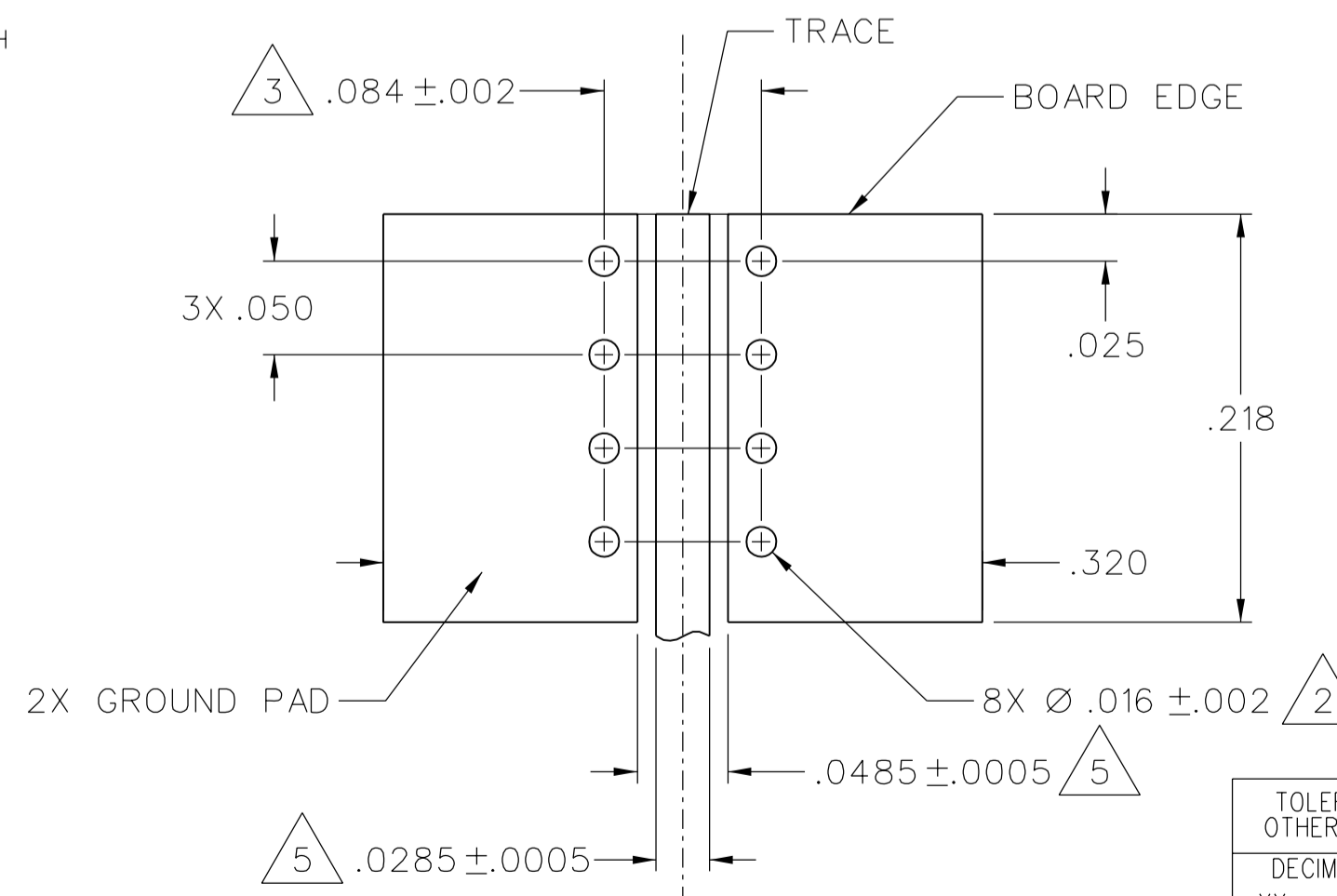

MOUNTING FOOTPRINT

10:1 (TOP VIEW, INCLUDING TRACE DIMENSIONS)

TOLERANCE UNLESS OTHERWISE SPECIFIED		DRAWN BY	DATE
DECIMALS	mm	JRK	11-2-04
.XX	_____	CHECKED BY	DATE
.XXX ±.003	_____	APPROVED BY	DATE
MATL	_____	JRK	12-15-04
FINISH	_____	RELEASE DATE	12-15-04
U/M	INCH	SCALE	10:1

Connectivity Solutions		EMERSON Network Power	
P.O. Box 1732		Waseca, MN 56093	
1-800-247-8256		TITLE	
HIGH FREQ END LAUNCH SMA JACK ASSEMBLY, EDGE MOUNT, 15 MIL PIN		SHEET	
DRAWING NO.		2 OF 2	
C - 142-0761-861/870		SCALE	

DRAWING NO. C - 142-0761-861/870			
0 REVISIONS			
ENGINEERING RELEASE			
1	11-5-04	JRK	12-15-04 ECN 49544
ADDED NOTE: 6			
***** * REVISION NUMBER FOLLOWED BY AN ALPHA * * CHARACTER INDICATES DRAWING CLARIFY * * CATION OR PART NUMBER ADDITION ONLY * *****			
1a	4-14-08	PAT	5-7-08 ECN 51481

CUSTOMER DRAWING

THIS DRAWING TO BE INTERPRETED PER ASME Y 14.5M - 1994

"μSTATION"

COMPANY CONFIDENTIAL