



750-085 Type J Series 75 Flexible Metal-Core Conduit

TYPE J NICKEL/IRON CONDUIT STAINLESS STEEL BRAID NEOPRENE JACKET *

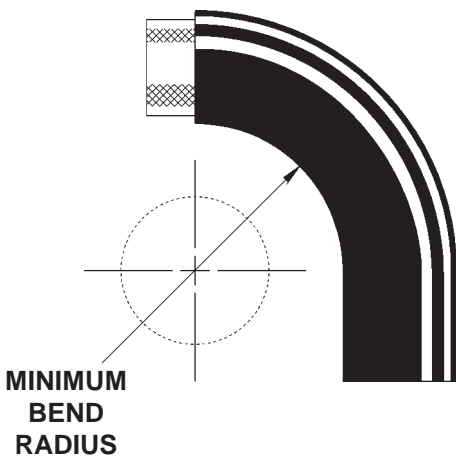
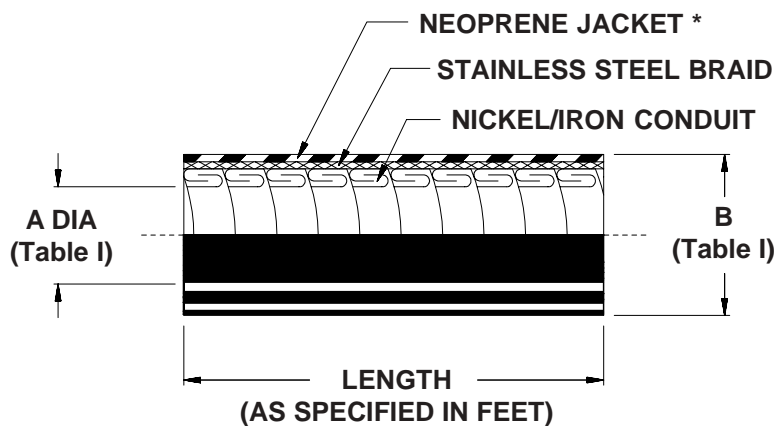
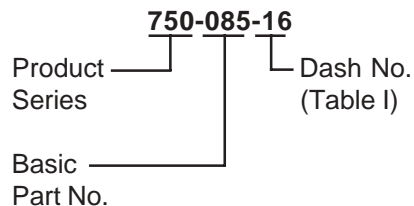

TABLE I			
DASH NO.	A DIA.	B DIA MAX	MINIMUM BEND RADIUS
08	.250 (6.4)	.562 (14.3)	1.250 (31.8)
12	.375 (9.5)	.740 (18.8)	1.875 (47.6)
16	.500 (12.7)	.890 (22.6)	2.500 (63.5)
20	.625 (15.9)	1.020 (25.9)	3.125 (79.4)
24	.750 (19.1)	1.140 (29.0)	3.750 (95.3)
32	1.000 (25.4)	1.450 (36.8)	5.000 (127.0)
40	1.250 (31.8)	1.700 (43.2)	6.250 (158.8)
48	1.500 (38.1)	1.950 (49.5)	7.500 (190.5)
56	1.750 (44.5)	2.195 (55.8)	8.750 (222.3)
64	2.000 (50.8)	2.485 (63.1)	10.000 (254.0)
80	2.500 (63.5)	2.985 (75.8)	12.500 (317.5)
96	3.000 (76.2)	3.485 (88.5)	15.000 (381.0)

Metric dimensions (mm) are in parentheses.

* For other jacket materials or for conduit without the jacket, consult the factory.