

**PLEASE CHECK WWW.MOLEX.COM FOR LATEST PART INFORMATION**

**Part Number:** [0008500005](#)  
**Status:** **Active**  
**Description:** KK® High Pressure Crimp Terminal 7879, 22-30 AWG, Bag Tin (Sn)

**Documents:**

[Drawing \(PDF\)](#) [RoHS Certificate of Compliance \(PDF\)](#)  
[Product Specification PS-7879 \(PDF\)](#)

**General**

Product Family Crimp Terminals  
 Series [7879](#)  
 Crimp Quality Equipment Yes  
 Product Name KK® High Pressure

**Physical**

Gender Female  
 Material - Metal Brass  
 Material - Plating Mating Tin  
 Material - Plating Termination Tin  
 Packaging Type Bag  
 Plating min: Mating (µin) 200  
 Plating min: Mating (µm) 5.00  
 Plating min: Termination (µin) 200  
 Plating min: Termination (µm) 5.00  
 Termination Interface: Style Crimp or Compression  
 Wire Insulation Diameter 1.57mm (.062") max.  
 Wire Size AWG 22, 24, 26, 28, 30  
 Wire Size mm² N/A

**Material Info**

Old Part Number 7879-1(P102)L

**Reference - Drawing Numbers**

Product Specification PS-7879  
 Sales Drawing SD-7879

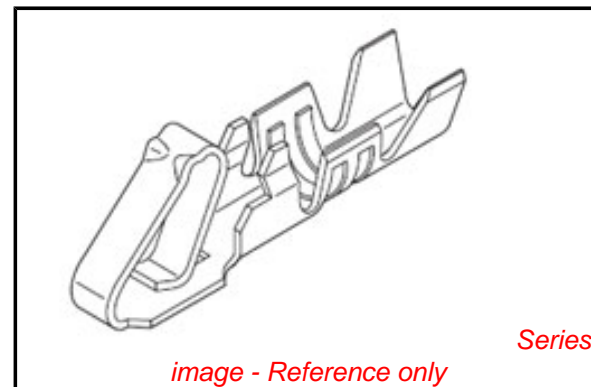

image - Reference only

**EU RoHS**

**ELV and RoHS  
 Compliant**  
**REACH SVHC  
 Contains SVHC: No**  
**Halogen-Free  
 Status**

**China RoHS**



**Need more information on product  
 environmental compliance?**

Email [productcompliance@molex.com](mailto:productcompliance@molex.com)  
 For a multiple part number RoHS Certificate of  
 Compliance, [click here](#)

Please visit the [Contact Us](#) section for any  
 non-product compliance questions.

**Search Parts in this Series**

[7879Series](#)

**Application Tooling | [FAQ](#)**

*Tooling specifications and manuals are  
 found by selecting the products below.  
 Crimp Height Specifications are then  
 contained in the Application Tooling  
 Specification document.*

**Global**

Description	Product #
Extraction Tool	<a href="#">0011030022</a>
Insertion Tool	<a href="#">0638120000</a>
Hand Crimp Tool	<a href="#">0638190800</a>

NOTES:

1. MATERIAL:
  - 1) 70/30 BRASS, PER ES-124C-6.
  - 2) PHOS. BRONZE, PER ES-124E-5.
2. FINISH: SEE LEGEND.
3. THIS PART CONFORMS TO PRODUCT SPEC. 7879.
4. CRIMP FOR 24-30 AWG. WIRE WITH .060/(1.52) MAX. INSULATION DIA.
5. THIS TERMINAL TO BE USED IN 7880 HOUSING.
6. DIMENSIONS GIVEN ACROSS CENTERLINES ARE SYMMETRICAL ABOUT THOSE CENTERLINES WITHIN HALF THE TOTAL TOLERANCE.
7. CRIMP WILL ACCEPT 22 AWG. WIRE WITH .062/(1.57) MAX. INSULATION DIA.

LEGEND:

7879-\*(\*\*\*)\*

MATERIAL  
 (.20<sup>+0.000</sup> / .020<sup>-0.008</sup>) / .008<sup>+0.0000</sup> / .0008<sup>-0.0008</sup> THICK

PLATING

(102) OVERALL TIN: .000200/(0.00508) MIN. OVER .000100/(0.00254) MIN. COPPER.  
 \*(P909) OVERALL HOT TN DP: .000100/(0.00254) MIN.  
 (P154) OVERALL TIN: .000100/(0.00254) MIN. OVERALL NICKEL UNDERPLATE: .000050/(0.00127) MIN.  
 (208) SELECT GOLD: .000015/(0.00038) MIN.  
 \*SELECT TIN: .000100/(0.00254) MIN.  
 OVERALL NICKEL UNDERPLATE: .000050/(0.00127) MIN.  
 (228) SELECT GOLD: .000030/(0.00076) MIN.  
 \*SELECT TIN: .000100/(0.00254) MIN.  
 OVERALL NICKEL UNDERPLATE: .000050/(0.00127) MIN.

\*THE PRIMARY SHIPPING CARTON WILL BE LABELED 'COMPLIANT TO RoHS DIRECTIVE 2002/95/EC AND ELY ANNEX II OF DIRECTIVE 2000/53/EC.' CARTONS WITHOUT THIS LABEL MAY CONTAIN PRODUCT WITH TIN-LEAD PLATING.

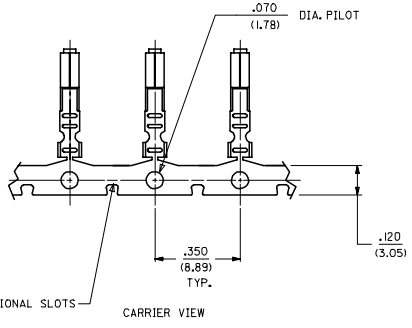
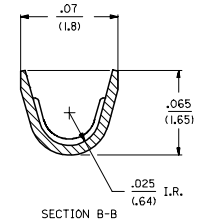
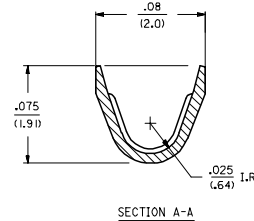
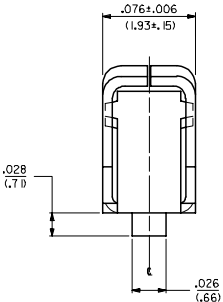
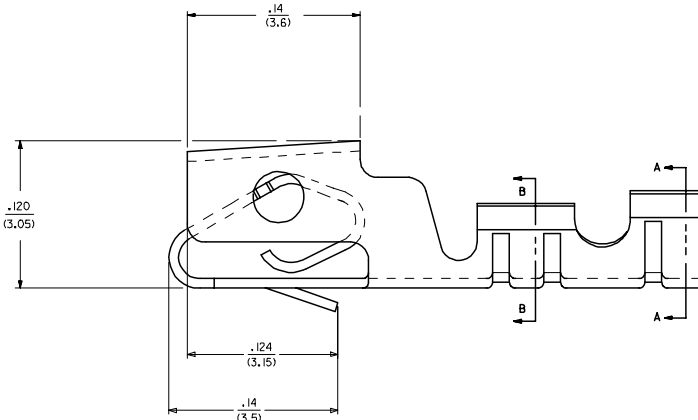
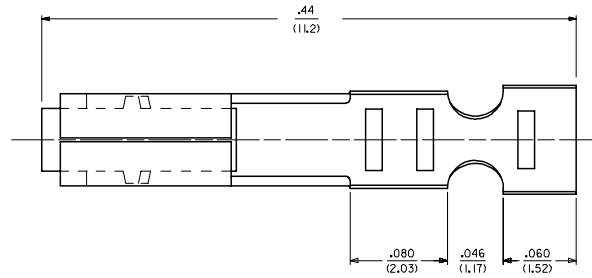

ADD EDP NO'S DEC NO: UCP2006-1006 2006/03/01 DURWALAHAG 2006/03/23 CHIKADDER 2006/03/23 APPRESMITH 2006/03/23 ZZ	QUALITY SYMBOLS ▽=0 ▽=0	GENERAL TOLERANCES (UNLESS SPECIFIED)		DIMENSION STYLE IN/MM		SCALE ---	DESIGN UNITS INCH	THIRD ANGLE PROJECTION	
		4 PLACES ± --- ± ---	3 PLACES ± --- ± .010	DRAWN BY GUZIK	DATE 12/22/88	TITLE (2.54)/.100 KK, CRIMP TYPE SHROUDED TERMINAL			
		2 PLACES ± 0.25 ± .014	1 PLACE ± 0.36 ± ---	CHECKED BY PATEL	DATE 12/22/88	APPROVED BY LENZ			
		ANGULAR ±1/2°		MATERIAL NO. SEE CHART		DOCUMENT NO. SD-7879		SHEET NO. 1 OF 2	
DRAFT WHERE APPLICABLE MUST REMAIN WITHIN DIMENSIONS				THIS DRAWING CONTAINS INFORMATION THAT IS PROPRIETARY TO MOLEX INCORPORATED AND SHOULD NOT BE USED WITHOUT WRITTEN PERMISSION					

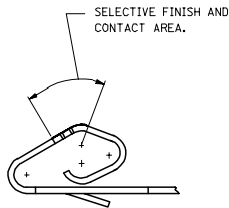

7879-1(***)*			7879-2(***)*		
PART NO.	ENG. NO		PART NO.	ENG. NO	
S 08-55-0128	7879-1P909I	PER ES-7879	50-29-1744	7879-2IP228I	PER ES-7879
S 08-55-0127	7879-1P909IL	PER ES-7879	50-29-1745	7879-2IP228IL	PER ES-7879
08-55-0124	7879-1P208	PER ES-7879		7879-2IP102I	PER ES-7879
				7879-2IP102IL	PER ES-7879
08-55-0129	7879-1P208IL	PER ES-7879			
08-50-0004	7879-1P102I	PER ES-7879			
08-50-0005	7879-1P102IL	PER ES-7879			
50-29-1900	7879-1P154I	PER ES-7879			

COLUMN NO. 1	CONT. IN COLUMN NO.	SHEET NO.	COLUMN NO. 2	CONT. IN COLUMN NO.	SHEET NO.	COLUMN NO. 3	CONT. IN COLUMN NO.	SHEET NO.
--------------	---------------------	-----------	--------------	---------------------	-----------	--------------	---------------------	-----------

ADD EDP NO'S REC NO: UCP2006-1006 2006/09/01 JORWNAELHAG 2006/09/29 CHKCADDER APPROVAL TH 2006/09/29 ZZ	QUALITY SYMBOLS ▽=0 ▽=0	GENERAL TOLERANCES (UNLESS SPECIFIED) <table border="1"> <tr> <th></th> <th>mm</th> <th>INCH</th> </tr> <tr> <td>4 PLACES</td> <td>± .005</td> <td>± .0005</td> </tr> <tr> <td>3 PLACES</td> <td>± .005</td> <td>± .0005</td> </tr> <tr> <td>2 PLACES</td> <td>± .005</td> <td>± .0005</td> </tr> <tr> <td>1 PLACE</td> <td>± .005</td> <td>± .0005</td> </tr> </table>			mm	INCH	4 PLACES	± .005	± .0005	3 PLACES	± .005	± .0005	2 PLACES	± .005	± .0005	1 PLACE	± .005	± .0005	DIMENSION STYLE IN/MM		SCALE ---	DESIGN UNITS INCH	<input checked="" type="checkbox"/> THIRD ANGLE PROJECTION
			mm	INCH																			
4 PLACES	± .005	± .0005																					
3 PLACES	± .005	± .0005																					
2 PLACES	± .005	± .0005																					
1 PLACE	± .005	± .0005																					
DRAFT WHERE APPLICABLE MUST REMAIN WITHIN DIMENSIONS		DRAWN BY GUZIK DATE 12/22/88		CHECKED BY PATEL DATE 12/22/88		APPROVED BY LENZ DATE 12/22/88		TITLE (2.54)/.100 KK, CRIMP TYPE SHROUDED TERMINAL MOLEX INCORPORATED DOCUMENT NO. SD-7879															