



Power LED Driver

2MHz High-Brightness LED Drivers with High-Side Current Sense and 5000:1 Dimming

FEATURES

- 5.5V to 40V Input Voltage Range
- High-Side Current Sense
- 20kHz Maximum Dimming Frequency
- Hysteretic Control: No Compensation
- 200mV Low Reference Voltage(5%)
- Dedicated Dimming Control Input
- Up to 2MHz Switching Frequency
- Adjustable Constant LED Current
- Up to 5A Constant Current Output
- 5V, 10mA On-Board Regulator
- -40°C to +125°C Operating Temperature Range
- SOT23-6 package

APPLICATIONS

- MR16 and Other LED Bulbs
- Power Led driver
- Constant Current Source

DESCRIPTION

The KB1365, step-down constant-current high-brightness LED (HB LED) drivers provide a cost-effective solution for automotive interior/exterior lighting, architectural and ambient lighting, LED bulbs such as MR16 and other LED illumination applications.

The KB1365 operate from a 5.5V to 40V input voltage range and feature a 5V/10mA on-board regulator. A high-side current-sense resistor adjusts the output current and a dedicated PWM input (DIM) enables a wide range of pulsed dimming.

The KB1365 is well suited for applications requiring a wide input voltage range. The high-side current-sensing and an integrated current-setting circuitry minimize the number of external components while delivering an LED current with +/-5% accuracy. A hysteretic control algorithm ensures excellent input-supply rejection and fast response during load transients and PWM dimming. The KB1365 features a 20% inductor current ripple. These devices operate up to 2MHz switching frequency, thus allowing for small component size.

SIMPLIFIED BLOCK DIAGRAM

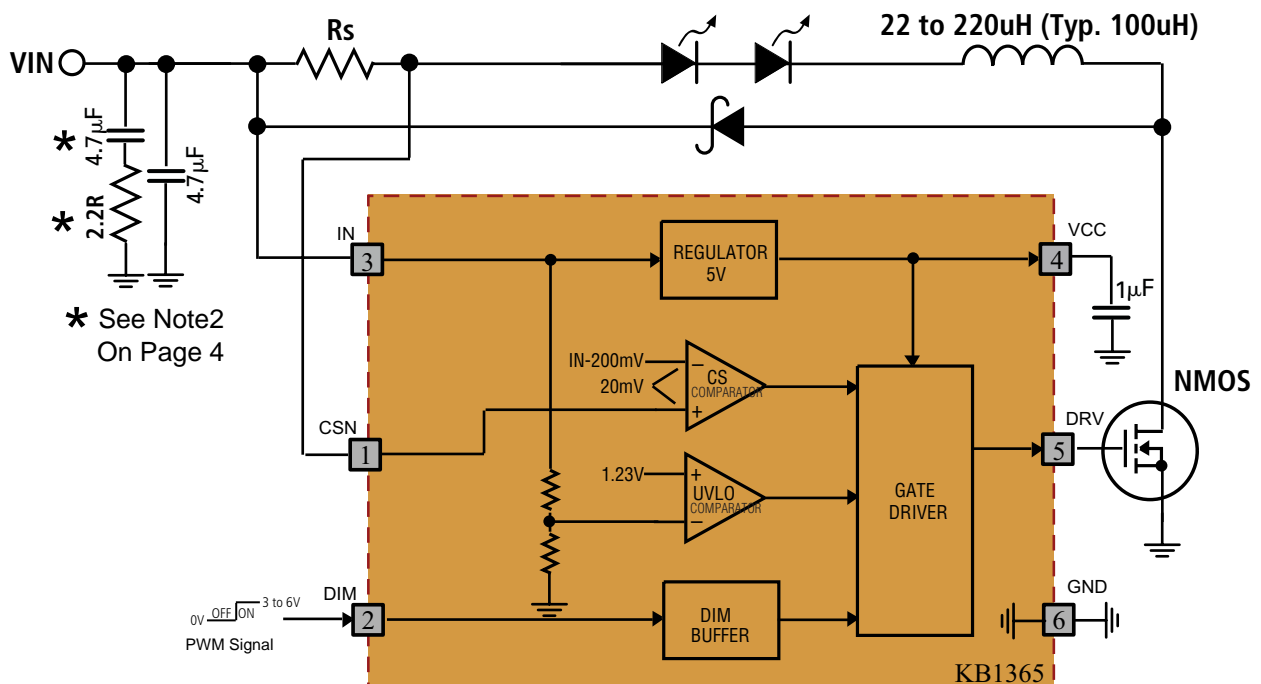



PIN CONFIGURATION

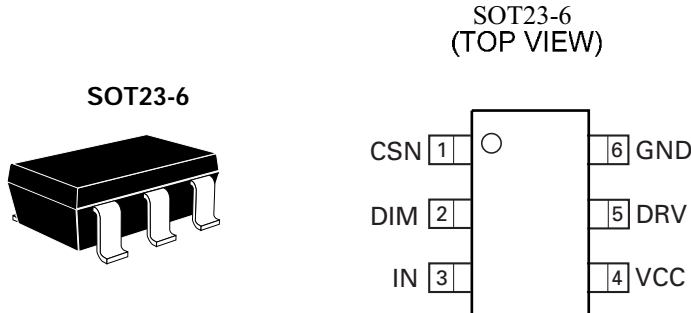

ORDER INFORMATION

| Part number | Package | Marking |
|-------------|----------------|--------------------------------------|
| KB1365GRE | SOT23-6, Green | xxxx, Date Code with one bottom line |

PIN DESCRIPTION

| PIN | NAME | FUNCTION |
|---------|------|---|
| 1 | IN | Positive Supply Voltage Input. Bypass with a 1 μ F or higher value capacitor to GND. |
| 2 | CSN | Current-Sense Input |
| 3 | DIM | Logic-Level Dimming Input. Drive DIM low to turn off the current regulator. Drive DIM high to enable the current regulator. |
| 4 | GND | Ground |
| 5 | DRV | Gate Drive Output. Connect to the gate of an external n-channel MOSFET. |
| 6 | VCC | Voltage Regulator Output. Connect a 1 μ F capacitor from VCC to GND. |
| SOT23-6 | | |

ABSOLUTE MAXIMUM RATINGS

IN, CSN, DIM to GND-0.3V to +40V
 VCC, DRV to GND-0.3V to +6V
 CSN to IN.....-0.3V to +0.3V
 Maximum Current into Any Pin
 (except IN, VCC, and DRV) \pm 20mA
 Continuous Power Dissipation (T_A = +70°C)
 6-Pin SOT.....350mW

Operating Temperature Range-40°C to +125°C
 Junction Temperature+150°C
 Storage Temperature Range-65°C to +150°C
 Lead Temperature (soldering, 10s)+300°C
 Pin-to-Pin ESD Ratings (HB Model).....2.5kV
 *As per JEDEC51 Standard (Single-Layer Board).

Stresses beyond those listed under "Absolute Maximum Ratings" may cause permanent damage to the device. These are stress ratings only, and functional operation of the device at these or any other conditions beyond those indicated in the operational sections of the specifications is not implied. Exposure to absolute maximum rating conditions for extended periods may affect device reliability.



RECOMMENDED OPERATION CONDITIONS

| Parameter | Symbol | Values | | | Unit |
|-----------------------|----------|--------|------|------|------|
| | | Min. | Typ. | Max. | |
| Power supply voltage | V_{IN} | 5.5 | — | 40 | V |
| Operating temperature | Top | -40 | +25 | +125 | °C |

ELECTRICAL CHARACTERISTICS

($V_{IN} = 12V$, $V_{DIM} = V_{CC}$ $C_{VCC} = 1\mu F$, $R_{SENSE} = 0.5\Omega$, $T_A = T_J = -40^\circ C$ to $+125^\circ C$, unless otherwise noted. Typical values are at $T_A = +25^\circ C$.) (Note 1)

| PARAMETER | SYMBOL | CONDITIONS | MIN | TYP | MAX | UNITS |
|---|--------------------|---|-----|-----|------|-------|
| Input Voltage Range | V_{IN} | | 5.5 | | 40.0 | V |
| Maximum Current Regulator Switching Frequency | f _{sw} | | | | 2 | MHz |
| Ground Current | I _{GND} | DRV open | | | 1.5 | mA |
| Supply Current | I _{IN} | $V_{DIM} < 0.6V$ | | | 425 | μA |
| Undervoltage Lockout | UVLO | $V_{IN} = V_{CSN} = V_{DIM}$, V_{IN} rising from 4V until $V_{DRV} > V_{CC} - 0.5V$ | | 4.7 | 5.0 | V |
| | | $V_{IN} = V_{CSN} = V_{DIM}$, V_{IN} falling from 6V, $V_{DRV} < 0.5V$ | | | 4.5 | |
| Undervoltage Lockout Hysteresis | | | | 0.5 | | V |
| SENSE COMPARATOR | | | | | | |
| Sense Voltage Threshold High | V _{SNSHI} | ($V_{IN} - V_{CSN}$) rising from 0V until $V_{DRV} < 0.5V$ (25°C) | 215 | 220 | 225 | mV |
| | | ($V_{IN} - V_{CSN}$) rising from 0V until $V_{DRV} < 0.5V$ (-40°C to +125°C) | 210 | 220 | 230 | |
| Sense Voltage Threshold Low | V _{SNSLO} | ($V_{IN} - V_{CSN}$) falling from 0.26V until $V_{DRV} > (V_{CC} - 0.5V)$ (25°C) | 175 | 180 | 185 | mV |
| | | ($V_{IN} - V_{CSN}$) falling from 0.26V until $V_{DRV} > (V_{CC} - 0.5V)$ (-40°C to +125°C) | 170 | 180 | 190 | |
| Propagation Delay to Output High | t _{DPDH} | Falling edge of ($V_{IN} - V_{CSN}$) from 0.26V to 0V to DRV high, $C_{DRV} = 1nF$ | | 82 | | ns |
| Propagation Delay to Output Low | t _{DPDL} | Rising edge of ($V_{IN} - V_{CSN}$) from 0V to 0.26V to DRV low, $C_{DRV} = 1nF$ | | 82 | | ns |
| Current-Sense Input Current | I _{CSN} | $(V_{IN} - V_{CSN}) = 200mV$ | | | 1 | μA |
| Current-Sense Threshold Hysteresis | C _{SHYS} | 0.5V (25°C) | | 40 | 50 | mV |
| | | 0.5V (-40°C to +125°C) | | 40 | 60 | mV |



ELECTRICAL CHARACTERISTICS

($V_{IN} = 12V$, $V_{DIM} = V_{CC}$ $C_{VCC} = 1\mu F$, $R_{SENSE} = 0.5\Omega$, $T_A = T_J = -40^\circ C$ to $+125^\circ C$, unless otherwise noted. Typical values are at $T_A = +25^\circ C$.) (Note 1)

| PARAMETER | SYMBOL | CONDITIONS | MIN | TYP | MAX | UNITS |
|---------------------------------|--------------|---|----------------|-----|-----|----------|
| GATE DRIVER | | | | | | |
| Gate Driver Source Current | | $V_{CSN} = V_{IN}$, $V_{DRV} = 0.5 \times V_{CC}$ | | 0.5 | | A |
| Gate Driver Sink Current | | $V_{CSN} = V_{IN} - 250mV$, $V_{DRV} = 0.5 \times V_{CC}$ | | 1 | | A |
| Gate Driver Output-Voltage High | V_{OH} | $I_{DRV} = 10mA$ | $V_{CC} - 0.5$ | | | V |
| Gate Driver Output-Voltage Low | V_{OL} | $I_{DRV} = -10mA$ | | | 0.5 | V |
| DIM INPUT | | | | | | |
| Maximum DIM Frequency | f_{DIM} | | | | 20 | kHz |
| DIM Input-Voltage High | V_{IH} | $V_{CSN} = V_{IN}$, increase DIM until $V_{DRV} > (V_{CC} - 0.5V)$ | 2.8 | | 6.0 | V |
| DIM Input-Voltage Low | V_{IL} | $V_{CSN} = V_{IN}$, decrease DIM until $V_{DRV} < 0.5V$ | | | 0.6 | V |
| DIM Hysteresis | DIM_{HYS} | | | 200 | | mV |
| DIM Turn-On Time | t_{DIMON} | DIM rising edge to $V_{DRV} = 0.5 \times V_{CC}$, $C_{DRV} = 1nF$ | | 100 | | ns |
| DIM Turn-Off Time | t_{DIMOFF} | DIM falling edge to $V_{DRV} = 0.5 \times V_{CC}$, $C_{DRV} = 1nF$ | | 100 | | ns |
| DIM Input Leakage High | | $V_{DIM} = V_{IN}$ | | | 10 | μA |
| DIM Input Leakage Low | | $V_{DIM} = 0V$ | -1 | | +1 | μA |
| V_{CC} REGULATOR | | | | | | |
| Regulator Output Voltage | V_{CC} | $I_{VCC} = 0.1mA$ to $10mA$, $V_{IN} = 5.5V$ to $40V$ | 4.5 | | 5.5 | V |
| | | $I_{VCC} = 0.1mA$ to $10mA$, $V_{IN} = 5.5V$ to $40V$ | 4.0 | | 5.5 | V |
| Load Regulation | | $I_{VCC} = 0.1mA$ to $10mA$, $V_{IN} = 12V$ | | 4 | | Ω |
| Line Regulation | | $V_{IN} = 6V$ to $40V$, $I_{VCC} = 10mA$ | | 11 | | mV |
| Power-Supply Rejection Ratio | PSRR | $V_{IN} = 12V$, $I_{VCC} = 5mA$, $f_{IN} = 10kHz$ | | -35 | | dB |
| Current Limit | I_{LIM} | $V_{IN} = 5.5V$, $V_{CC} = 0V$ | | 45 | | mA |
| | | $V_{IN} = 5.5V$, $V_{CC} = 4V$ | | 18 | | mA |
| Regulator Startup Time | t_{STRAT} | $V_{CC} = 0$ to $5.5V$ | | 350 | | us |

Note 1: All devices are 100% production tested at $T_J = +25^\circ C$ and $+125^\circ C$. Limits to $-40^\circ C$ are guaranteed by design.

Note 2: V_{in} Bypass Capacitor

Many types of capacitors can be used for input bypassing, however, caution must be exercised when using multi-layer ceramic capacitors. Because of the self-resonant and high Q characteristics of some types of ceramic capacitors, high voltage transients can be generated under some start-up conditions, such as connecting the charger input to a live power source. Adding a 2.2Ω resistor in series with an X5R ceramic capacitor will minimize start-up voltage transients.

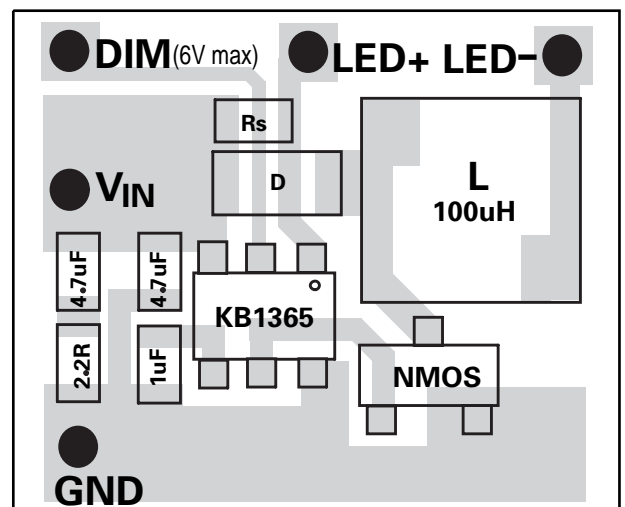

Layout suggestion



TYPICAL PERFORMANCE CHARACTERISTICS

($V_{IN} = V_{DIM} = 12V$, $C_{VCC} = 1\mu F$, $R_{SENSE} = 0.5\Omega$ connected between IN and CSN. Typical values at $T_A = +25^\circ C$, unless otherwise noted.)

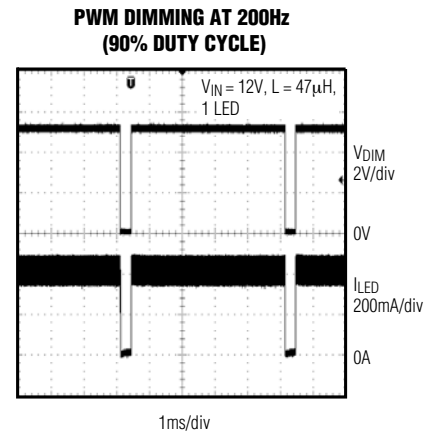
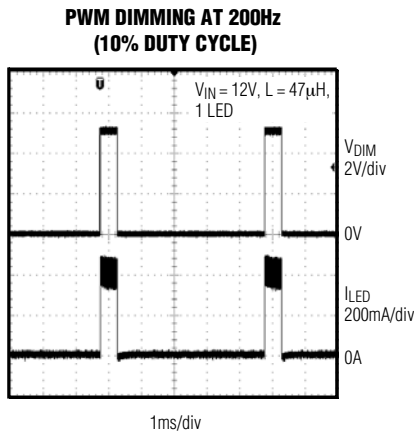
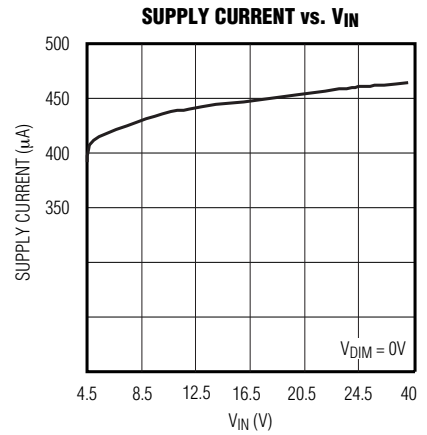
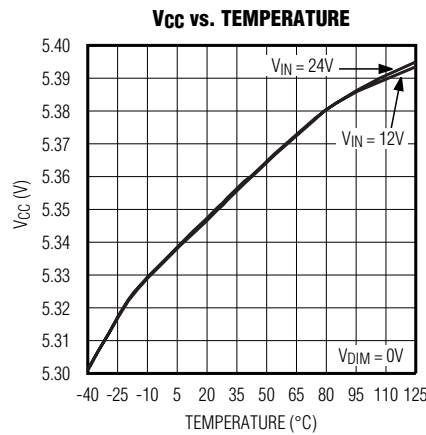
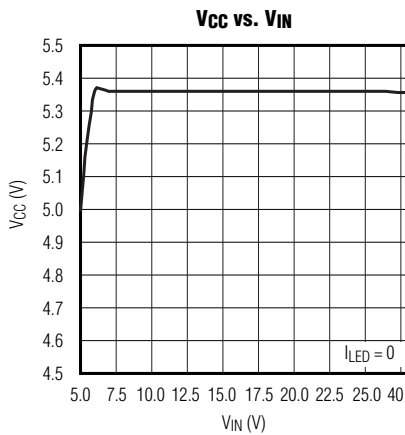
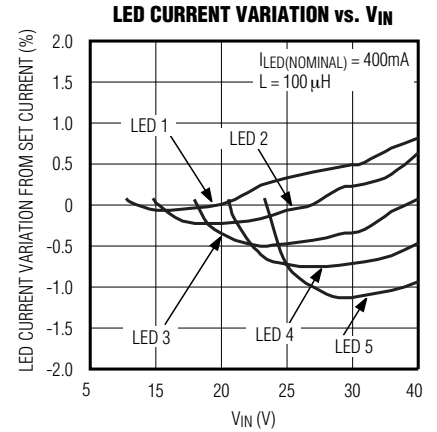
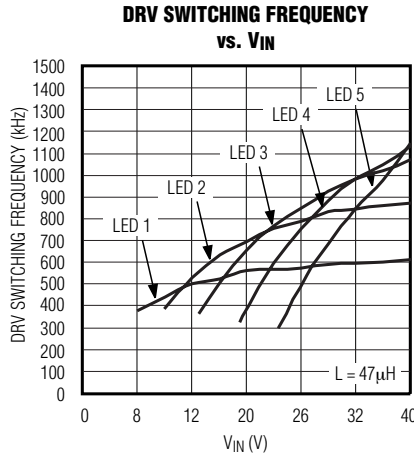
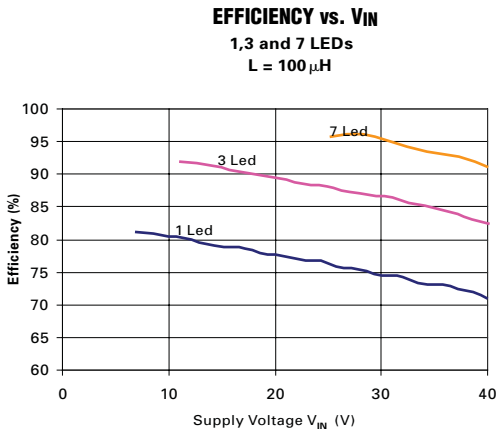



TYPICAL PERFORMANCE CHARACTERISTICS

($V_{IN} = V_{DIM} = 12V$, $C_{VCC} = 1\mu F$, $R_{SENSE} = 0.5\Omega$ connected between IN and CSN. Typical values at $T_A = +25^\circ C$, unless otherwise noted.)

**PWM DIMMING AT 200Hz
(1% DUTY CYCLE)**

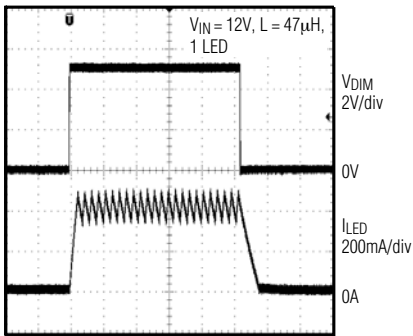

10µs/div

**PWM DIMMING EXPANDED
(50% DUTY CYCLE)**

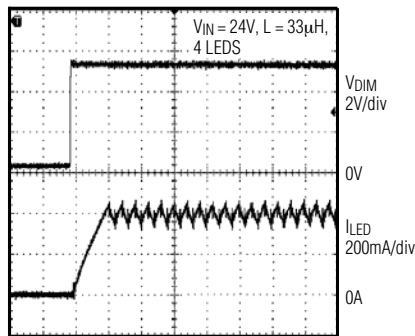

1µs/div

**PWM DIMMING EXPANDED
(50% DUTY CYCLE)**

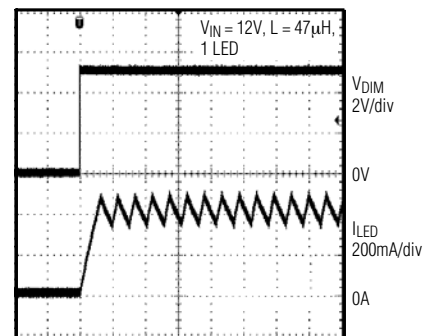

4µs/div

**PWM DIMMING AT 20kHz
(10% DUTY CYCLE)**

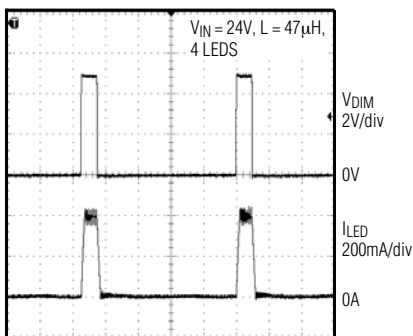

10µs/div

**PWM DIMMING AT 20kHz
(90% DUTY CYCLE)**

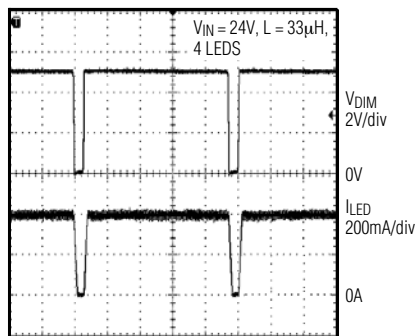

10µs/div

ILED VARIATION vs. TEMPERATURE

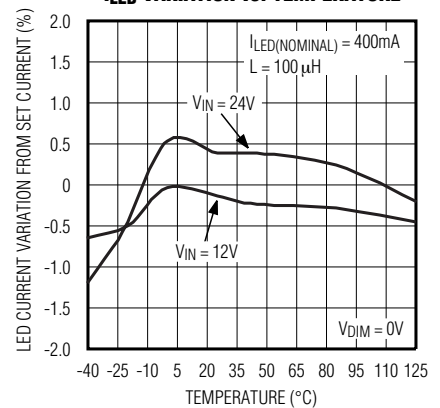



Detailed Description

The KB1365 are step-down, constant-current, high-brightness LED (HB LED) drivers. These devices operate from a 5.5V to 40V input voltage range and provide up to 0.5A of source and 1A of sink drive capability to the gate of an external MOSFET. A high-side current-sense resistor sets the output current and

Undervoltage Lockout (UVLO)

The KB1365 include a 5.0V undervoltage lockout (UVLO) with 500mV hysteresis. When V_{IN} falls below 4.5V, DRV goes low, turning off the external n-channel MOSFET. DRV goes high once V_{IN} is 5V or higher.

5V Regulator

VCC is the output of a 5V regulator capable of sourcing 10mA. Bypass VCC to GND with a 1 μ F capacitor.

DIM Input

The KB1365 allow dimming with a PWM signal at the DIM input. A logic level below 0.6V at DIM forces the KB1365's DRV output low, turning off the LED current. To turn the LED current on, the logic level at DIM must be at least 2.8V.

a dedicated PWM dimming input (DIM) allows for a wide range of independent pulsed dimming.

The high-side current-sensing scheme and on-board current-setting circuitry minimize the number of external components while delivering LED current with a $\pm 5\%$ accuracy, using a 1% sense resistor. See the *Functional Diagram*.

For the values of V_{SNSHI} and V_{SNSLO} , see the *Electrical Characteristics*.

Current Regulator Operation

The KB1365 regulate the LED output current using an input comparator with hysteresis (Figure 1). As the current through the inductor ramps up and the voltage across the sense resistor reaches the upper threshold, the voltage at DRV goes low, turning off the external MOSFET. The MOSFET turns on again when the inductor current ramps down through the freewheeling diode until the voltage across the sense resistor equals the lower threshold. Use the following equation to determine the operating frequency:

$$f_{SW} = \frac{(V_{IN} - n \times V_{LED}) \times n \times V_{LED} \times R_{SENSE}}{V_{IN} \times \Delta V \times L}$$

where n = number of LEDs, V_{LED} = forward voltage drop of one LED, and $\Delta V = (V_{SNSHI} - V_{SNSLO})$.

Applications Information

Setting nominal average output current with external resistor R_S

The nominal average output current in the LED(s) is determined by the value of the external current sense resistor (R_S) connected between V_{IN} and CSN and is given by:

$$I_{OUTnom} = 0.2/R_S$$

The table below gives values of nominal average output current for several preferred values of current setting resistor (R_S) in the typical application circuit shown on page 1:

| R_S (Ω) | Nominal average output current (mA) | R_S Power (w) |
|--------------------|-------------------------------------|-----------------|
| 0.1 | 2000 | 0.4 |
| 0.2 | 1000 | 0.2 |
| 0.57 | 350 | 0.07 |

Inductor selection

Recommended inductor values for the KB1365 are in the range 22 μ H to 220 μ H(100 μ H Typ.).



APPLICATION CIRCUIT

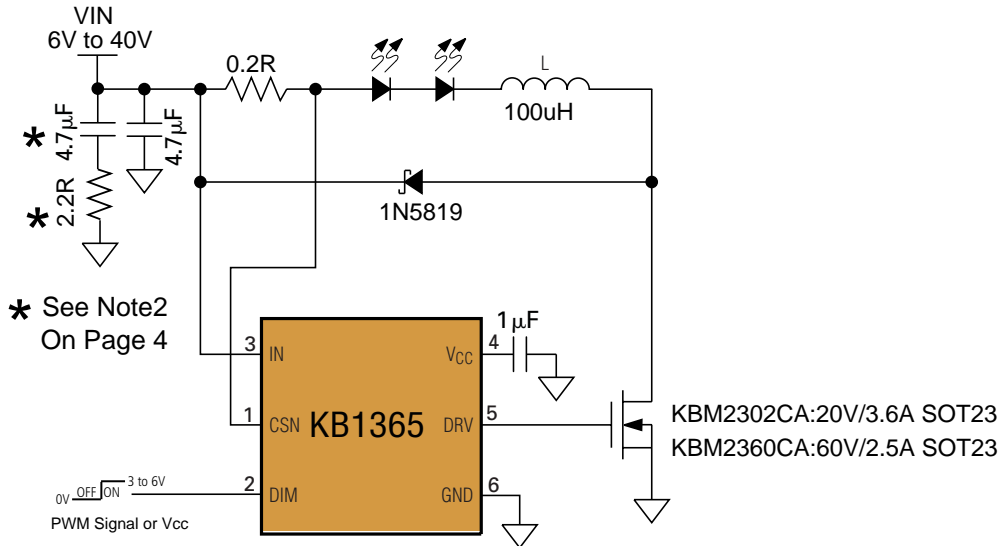

Figure 1a. KB1365 Typical Application Circuit with 1A Output .

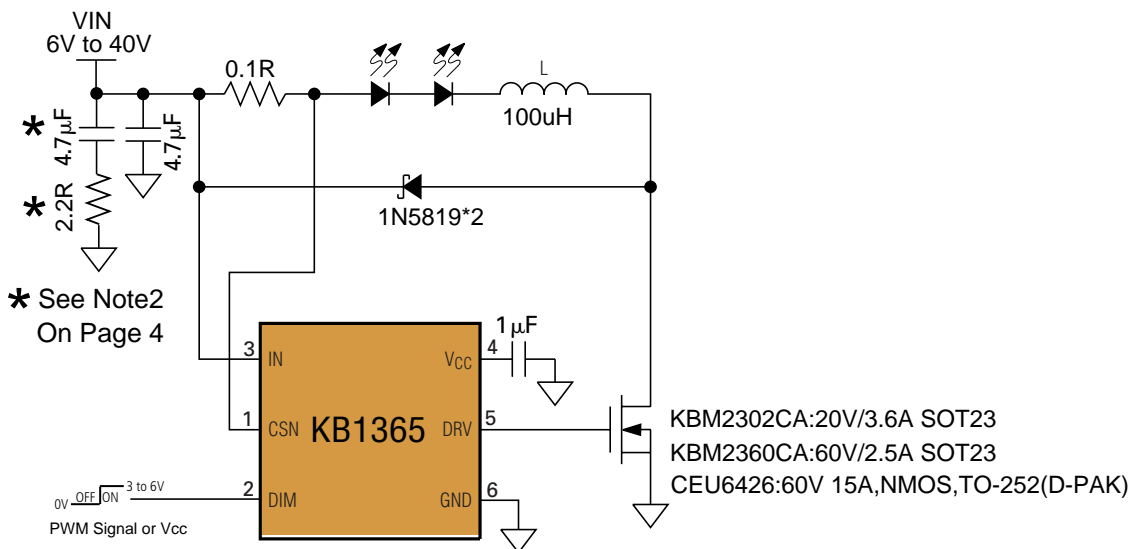

Figure 1a. KB1365 Typical Application Circuit with 2A Output .



PACAGE DESCRIPTION

Small Outline SOT23-6

PACKAGE OUTLINE

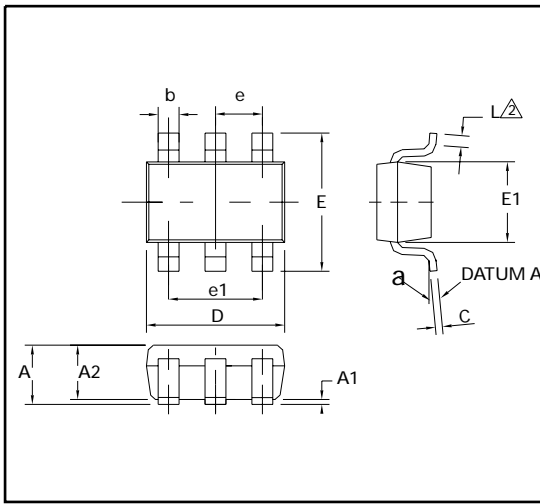

PAD LAYOUT DETAILS

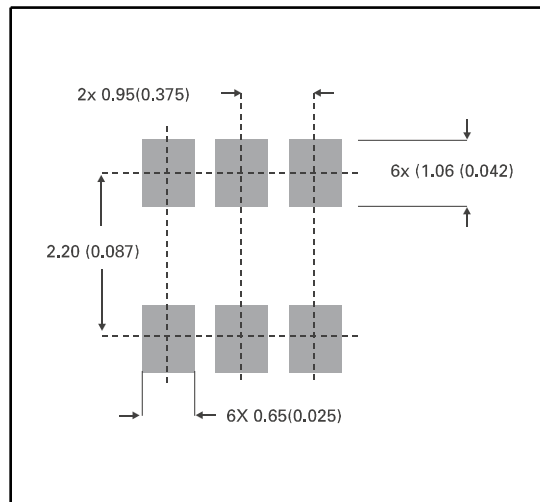

CONTROLLING DIMENSIONS IN MILLIMETRES APPROX CONVERSIONS INCHES.

PACKAGE DIMENSIONS

| DIM | Millimetres | | Inches | | DIM | Millimetres | | Inches | |
|-----|-------------|------|--------|-------|-----|-------------|------|-----------|-------|
| | Min | Max | Min | Max | | Min | Max | Min | Max |
| A | 0.90 | 1.45 | 0.35 | 0.057 | E | 2.60 | 3.00 | 0.102 | 0.118 |
| A1 | 0.00 | 0.15 | 0 | 0.006 | E1 | 1.50 | 1.75 | 0.059 | 0.069 |
| A2 | 0.90 | 1.30 | 0.035 | 0.051 | L | 0.10 | 0.60 | 0.004 | 0.002 |
| b | 0.35 | 0.50 | 0.014 | 0.019 | e | 0.95 REF | | 0.037 REF | |
| C | 0.09 | 0.20 | 0.0035 | 0.008 | e1 | 1.90 REF | | 0.074 REF | |
| D | 2.80 | 3.00 | 0.110 | 0.118 | L | 0° | 10° | 0° | 10° |