

General Description

The AAT1152 SwitchReg is a step-down switching converter ideal for applications where high efficiency, small size, and low ripple are critical. Able to deliver 1A with internal power MOSFETs, the current mode controlled IC is internally compensated for simplified system design and low external parts count.

The AAT1152 features a Power-OK (POK) function which monitors the output, alerting the system if the output voltage falls out of regulation.

The AAT1152 is available in a Pb-free MSOP-8 package and is rated over the -40°C to +85°C temperature range.

Features

- 5.5V Max Supply Input
- Fixed or Adjustable V_{OUT} 1.0V to 4.2V
- 1A Output Current
- Integrated Low On Resistance Power Switches
- Up to 95% Efficiency
- Power-OK Signal
- Internally Compensated Current Mode Control
- High Initial Accuracy: $\pm 1\%$
- 850kHz Switching Frequency
- Constant Pulse Width Modulation (PWM) Mode
- Low Output Ripple with Light Load
- Internal Soft Start
- Current Limit Protection
- Over-Temperature Protection
- MSOP-8 Package
- -40°C to +85°C Temperature Range

Applications

- Cable/DSL Modems
- Computer Peripherals
- High Efficiency Conversion from 5V or 3.3V Supply
- Network Cards
- Set-Top Boxes

Typical Application

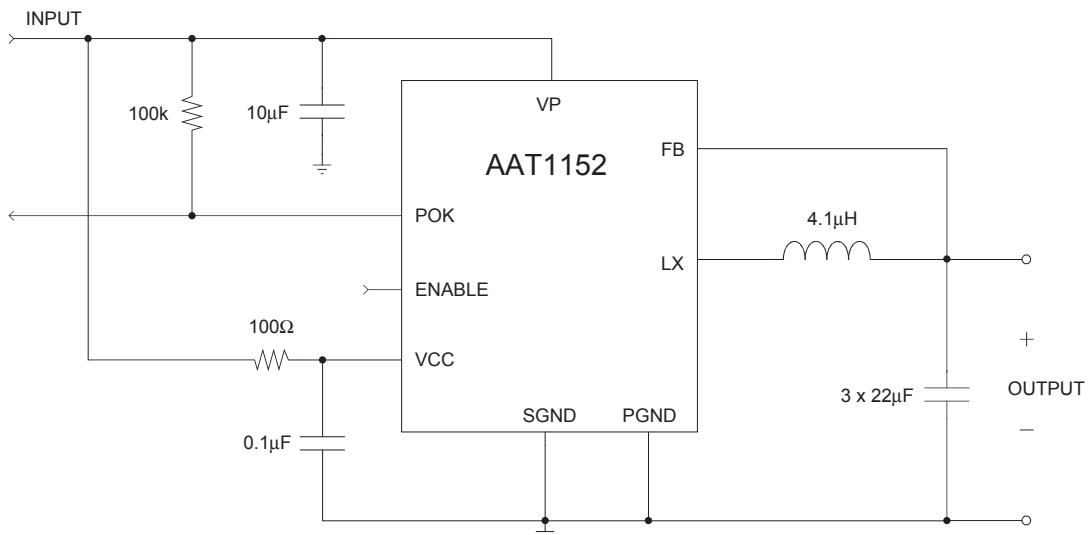

Pin Descriptions

Pin #	Symbol	Function
1	FB	Feedback input pin.
2	SGND	Signal ground.
3	EN	Converter enable pin.
4	VCC	Small signal filtered bias supply.
5	VP	Input supply for converter power stage.
6	LX	Inductor connection pin.
7	POK	Power-OK indicator. Open-drain output is low when V_{OUT} falls out of regulation.
8	PGND	Power ground return for output stage.

Pin Configuration

MSOP-8

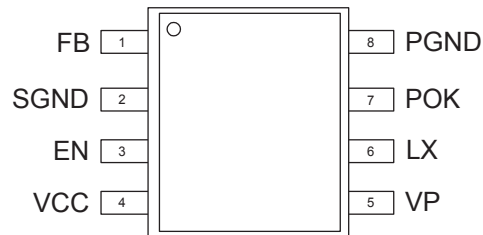

Absolute Maximum Ratings¹

$T_A = 25^\circ\text{C}$, unless otherwise noted.

Symbol	Description	Value	Units
V_{CC}, V_P	VCC, VP to GND	6	V
V_{LX}	LX to GND	-0.3 to $V_P + 0.3$	V
V_{FB}	FB to GND	-0.3 to $V_{CC} + 0.3$	V
V_{EN}, V_{POK}	POK, EN to GND	-0.3 to 6	V
T_J	Operating Junction Temperature Range	-40 to 150	$^\circ\text{C}$
T_{LEAD}	Maximum Soldering Temperature (at leads, 10 sec)	300	$^\circ\text{C}$
V_{ESD}	ESD Rating ² - HBM	3000	V

Thermal Characteristics³

Symbol	Description	Value	Units
Θ_{JA}	Maximum Thermal Resistance (MSOP-8)	150	$^\circ\text{C}/\text{W}$
P_D	Maximum Power Dissipation (MSOP-8)	833	mW

Recommended Operating Conditions

Symbol	Description	Rating	Units
T	Ambient Temperature Range	-40 to +85	$^\circ\text{C}$

1. Stresses above those listed in Absolute Maximum Ratings may cause permanent damage to the device. Functional operation at conditions other than the operating conditions specified is not implied. Only one Absolute Maximum Rating should be applied at any one time.
2. Human body model is a 100pF capacitor discharged through a 1.5k Ω resistor into each pin.
3. Mounted on a demo board.

Electrical Characteristics

$V_{IN} = V_{CC} = V_P = 5V$, $T_A = -40^{\circ}C$ to $+85^{\circ}C$, unless otherwise noted. Typical values are at $T_A = 25^{\circ}C$.

Symbol	Description	Conditions	Min	Typ	Max	Units
V_{IN}	Operation Voltage		2.7		5.5	V
V_{OUT}	DC Output Voltage Tolerance	$I_{OUT} = 500mA$ $T_A = 25^{\circ}C$ Full Temp	-1.0 -2.0		1.0 2.0	%
I_{LIM}	Current Limit	$T_A = 25^{\circ}C$	1.2			A
I_Q	Quiescent Supply Current	No Load, $V_{FB} = 0$		160	300	μA
$\Delta V_{OUT} (V_{OUT} * \Delta V_{IN})$	Load Regulation	$V_{IN} = 4.2V$, $I_{LOAD} = 0$ to 1A		3		%
$\Delta V_{OUT}/V_{OUT}$	Line Regulation	$V_{IN} = 2.7V$ to 5.5V		0.2		%/V
F_{OSC}	Oscillator Frequency	$T_A = 25^{\circ}C$	700	850	1000	kHz
$R_{DSON(H)}$	High-Side Switch On Resistance	$T_A = 25^{\circ}C$		110	150	m Ω
$R_{DSON(L)}$	Low-Side Switch On Resistance	$T_A = 25^{\circ}C$		100	150	m Ω
$V_{EN(H)}$	Enable Input High Voltage	$V_{IN} = 2.7V$ to 5.5V	1.4			V
$V_{EN(L)}$	Enable Input Low Voltage	$V_{IN} = 2.7V$ to 5.5V			0.6	V
I_{EN}	Enable Pin Leakage Current	$V_{EN} = 5.5V$			1	μA
V_{UVLO}	Under-Voltage Lockout	V_{IN} Rising V_{IN} Falling			2.5	V
$V_{UVLO(hys)}$	Under-Voltage Lockout Hysteresis			250		mV
T_{SD}	Over-Temperature Shutdown Threshold			140		$^{\circ}C$
T_{HYS}	Over-Temperature Shutdown Hysteresis			15		$^{\circ}C$
I_{SHDN}	Shutdown Current	$V_{EN} = 0$, $V_{IN} = 5.5V$			1	μA
$V_{TH(POK)}$	Power-OK Threshold	V_{FB} Ramping Up V_{FB} Ramping Down		90 88		% of V_{FB}
R_{POK}	Power-OK Pull-Down On Resistance			4		Ω

Typical Characteristics

Efficiency vs. Output Current
($V_{OUT} = 1.5V$)

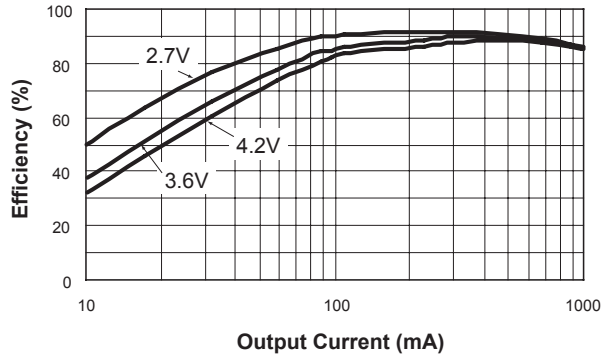

High Side $R_{DS(ON)}$ vs. Temperature

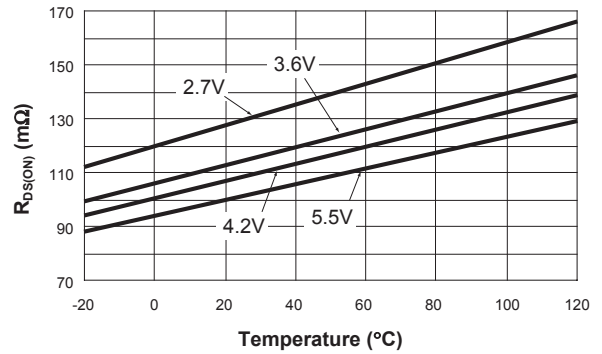

Low Side $R_{DS(ON)}$ vs. Temperature

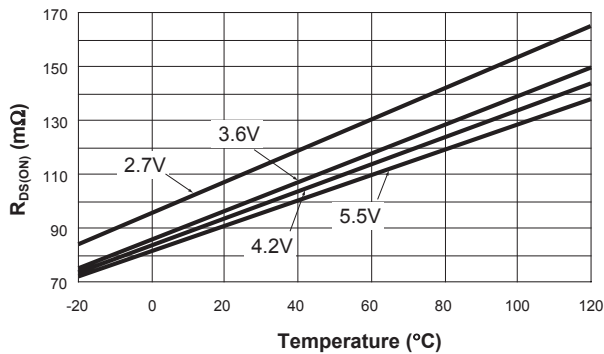

$R_{DS(ON)}$ vs. Input Voltage

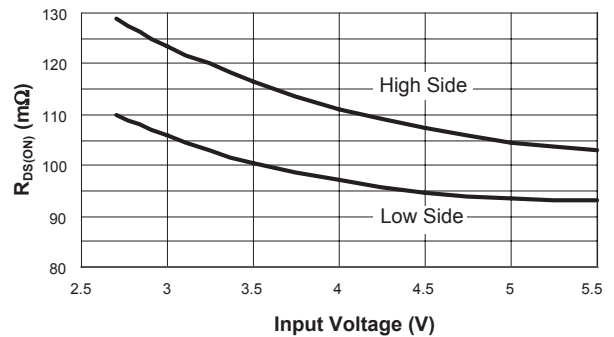

Enable Threshold vs. Input Voltage

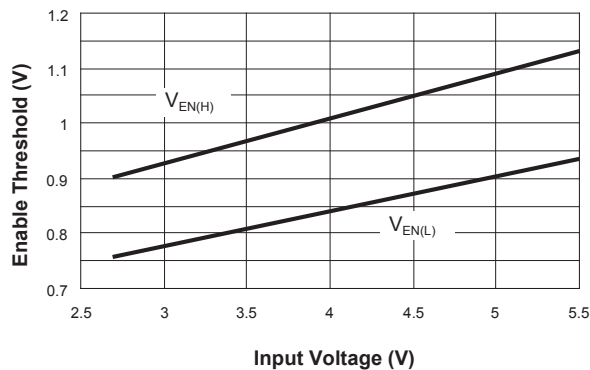

Oscillator Frequency Variation vs. Supply Voltage

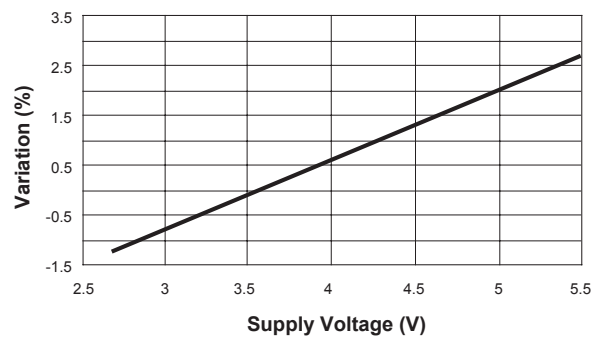

Typical Characteristics

Oscillator Frequency Variation vs. Temperature
($V_{IN} = 3.6V$)

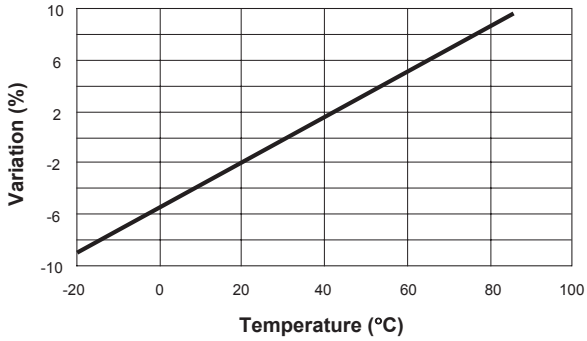

Output Voltage vs. Temperature
($I_{OUT} = 900mA$; $V_{OUT} = 1.5V$)

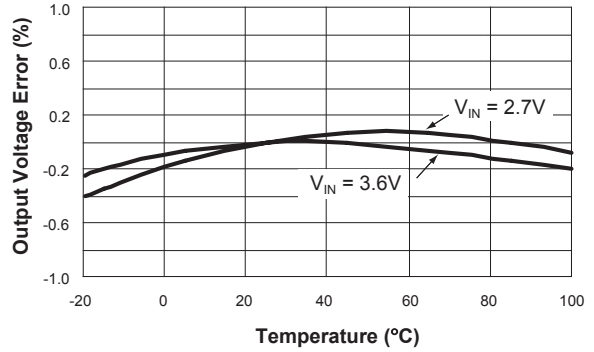

Line Regulation
($V_{OUT} = 1.5V$)

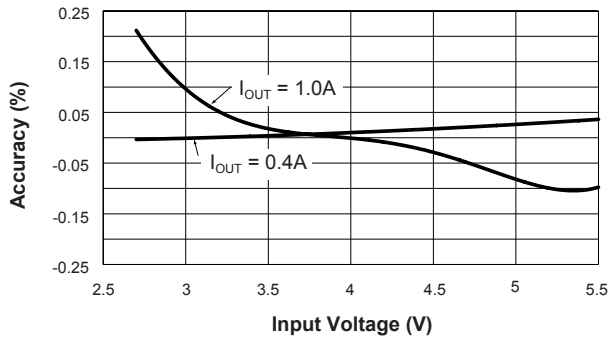

Load Regulation
($V_{OUT} = 1.5V$; $V_{IN} = 3.6V$)

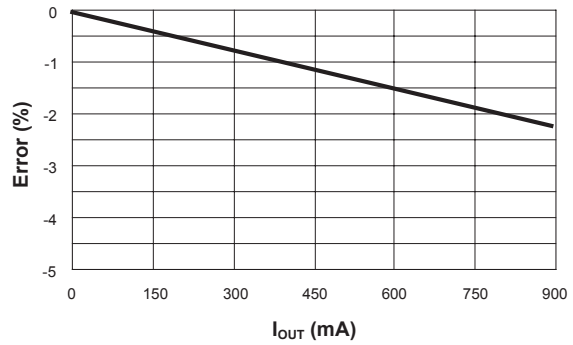

Load Regulation
($V_{OUT} = 3.3V$; $V_{IN} = 5.0V$)

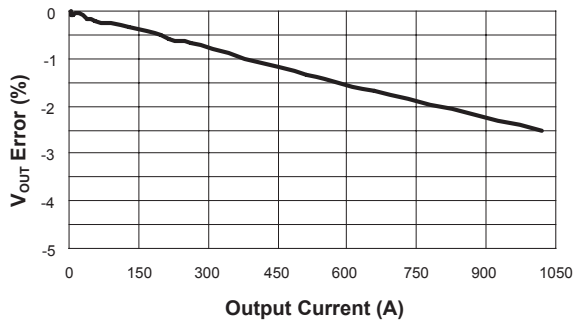

Efficiency vs. Input Voltage
($V_{OUT} = 1.5V$)

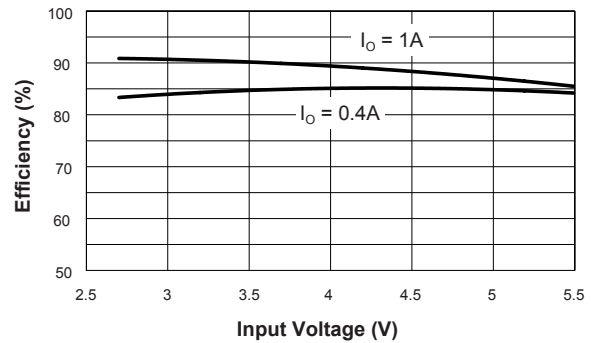

Typical Characteristics

AAT1152 Loop Gain and Phase
($C_o = 22\mu\text{F}$; $V_o = 1.5\text{V}$; $V_{in} = 3.6\text{V}$; $I_o = 1\text{A}$)

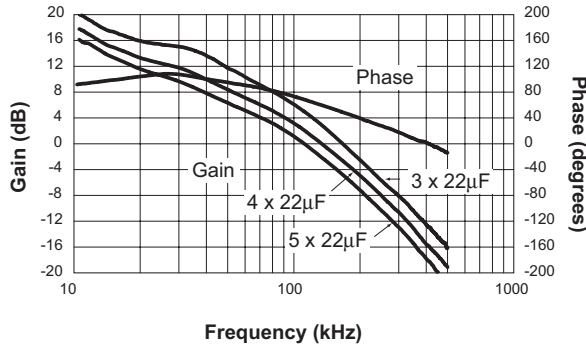

No Load Input Current vs. Temperature
($V_{CC} = V_P$)

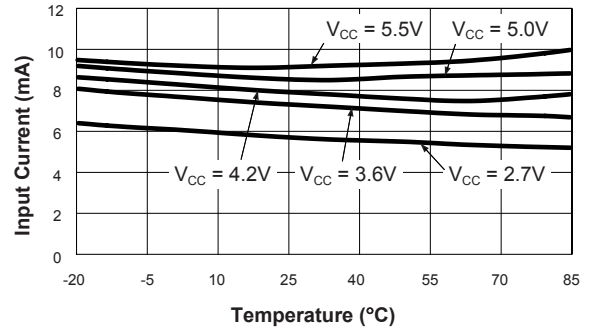

Non-Switching I_o vs. Temperature
($F_B = 0\text{V}$; $V_P = V_{CC}$)

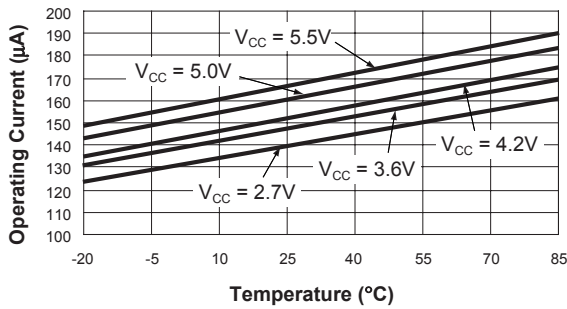

Switching Waveform
($V_{in} = 3.6\text{V}$; $V_{out} = 1.5\text{V}$; $I_{out} = 1.2\text{A}$)

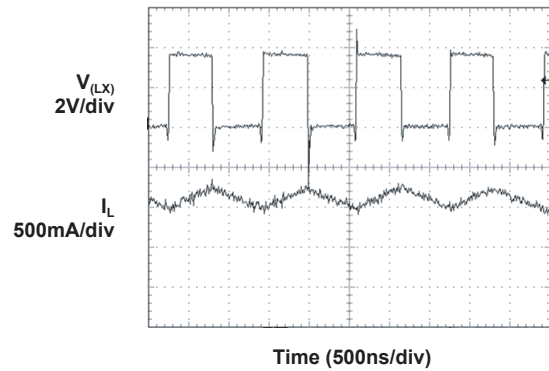

Transient Response
($V_{in} = 3.6\text{V}$; $V_{out} = 1.5\text{V}$; $I_{load} = 0.25$ to 1.2A)

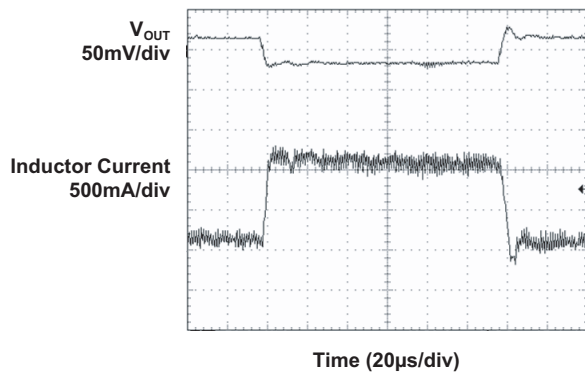

Output Ripple
($V_{in} = 3.6\text{V}$; $V_{out} = 1.5\text{V}$; $I_{out} = 0\text{A}$)

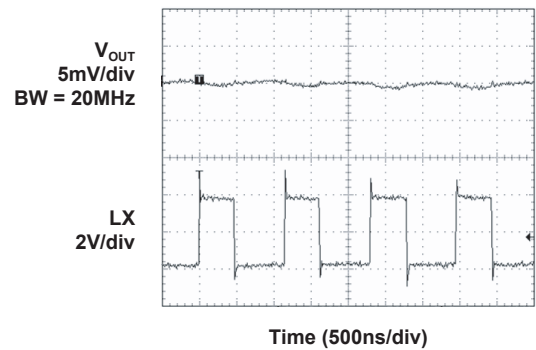

Typical Characteristics

Output Ripple
($V_{IN} = 3.6V$; $V_{OUT} = 1.5V$; $I_{OUT} = 1A$)

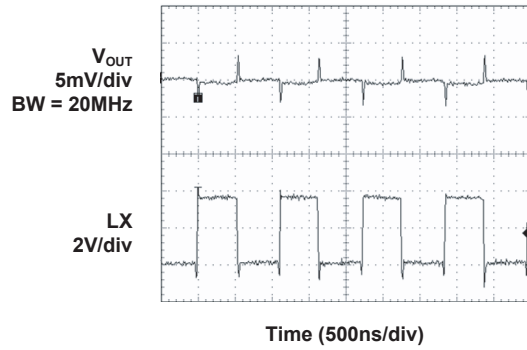

Output Ripple
($V_{IN} = 5.0V$; $V_{OUT} = 3.3V$; $I_{OUT} = 0A$)

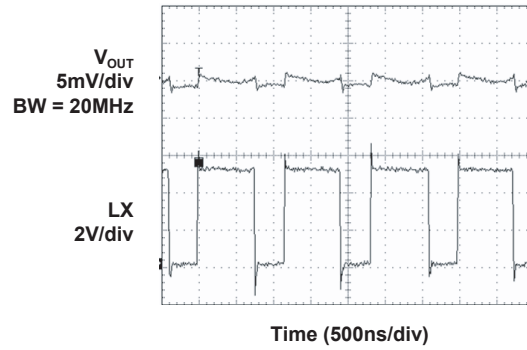

Output Ripple
($V_{IN} = 5.0V$; $V_{OUT} = 3.3V$; $I_{OUT} = 1A$)

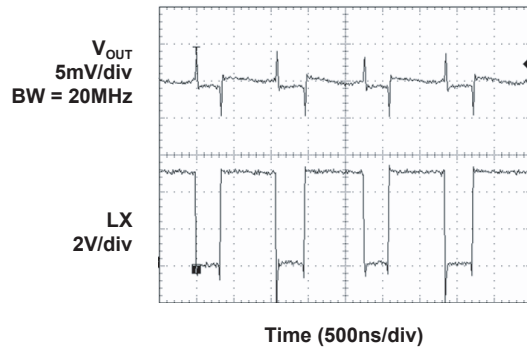

Functional Block Diagram

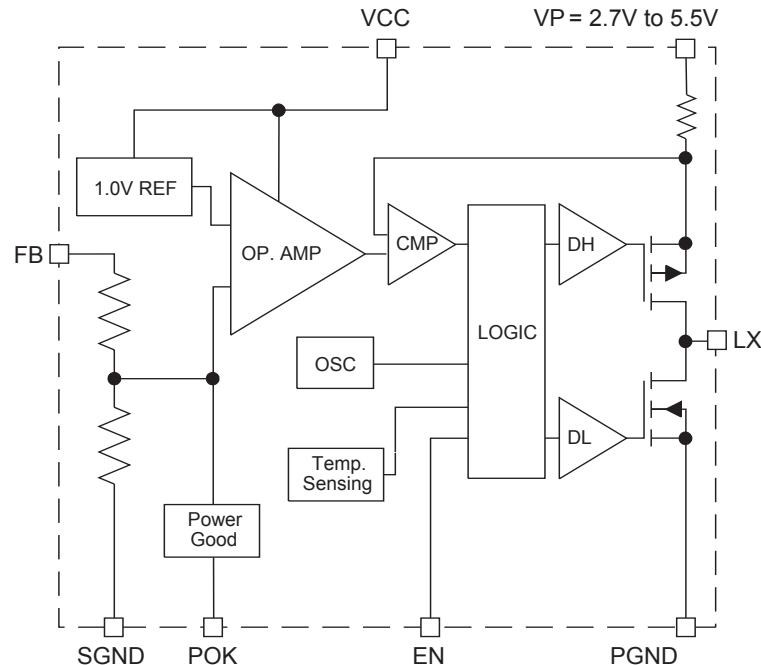

Applications Information

Control Loop

The AAT1152 is a peak current mode buck converter. The inner wide bandwidth loop controls the peak current of the output inductor. The output inductor current is sensed through the P-channel MOSFET (high side) and is also used for short-circuit and overload protection. A fixed slope compensation signal is added to the sensed current to maintain stability. The loop appears as a voltage-programmed current source in parallel with the output capacitor.

The voltage error amplifier output programs the current loop for the necessary inductor current to force a constant output voltage for all load and line conditions. The feedback resistive divider is internal, dividing the output voltage to the error amplifier ref-

erence voltage of 1V. The error amplifier does not have the large DC gain typical of most error amplifiers. This eliminates the need for external compensation components, while still providing sufficient DC loop gain for load regulation. The crossover frequency and phase margin are set by the output capacitor value only.

Soft Start/Enable

Soft start increases the inductor current limit point in discrete steps when the input voltage or enable input is applied. It limits the current surge seen at the input and eliminates output voltage overshoot (see Figure 1). When pulled low, the enable input forces the AAT1152 into a low-power, non-switching state. The total input current during shutdown is less than 1 μ A.

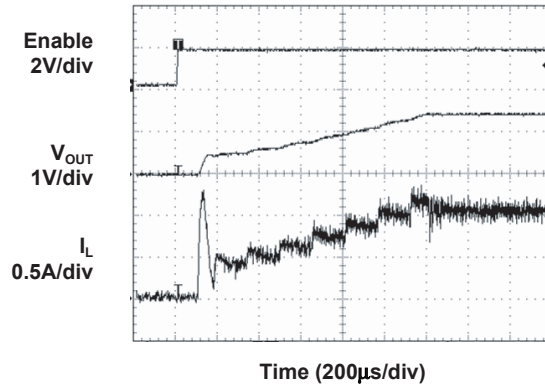

Figure 1: Inrush Limit ($V_{IN} = 3.6V$; $V_{OUT} = 1.5V$; $I_L = 1A$).

Current Limit and Over-Temperature Protection

For overload conditions, the peak input current is limited. Figure 2 displays the current limit characteristics. As load impedance decreases and the output voltage falls closer to zero, more power is dissipated internally, raising the device temperature. Thermal protection completely disables switching when internal dissipation becomes excessive, protecting the device from damage. The junction over-temperature threshold is 140°C with 15°C of hysteresis.

Power and Signal Source

Separate small signal ground and power supply pins isolate the internal control circuitry from the noise associated with the output MOSFET switching. The low pass filter R1 and C3 (shown in schematic Figures 3 and 4) filters the noise associated with power switching.

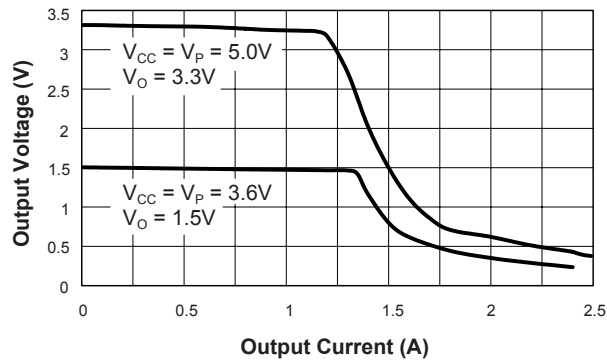

Figure 2: Current Limit Characteristics.

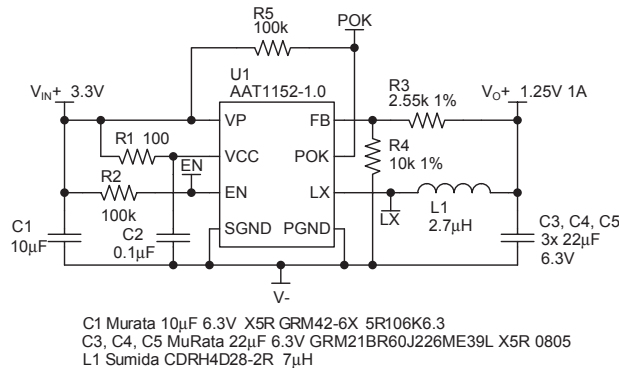

Figure 3: 3.3V to 1.25V Converter.

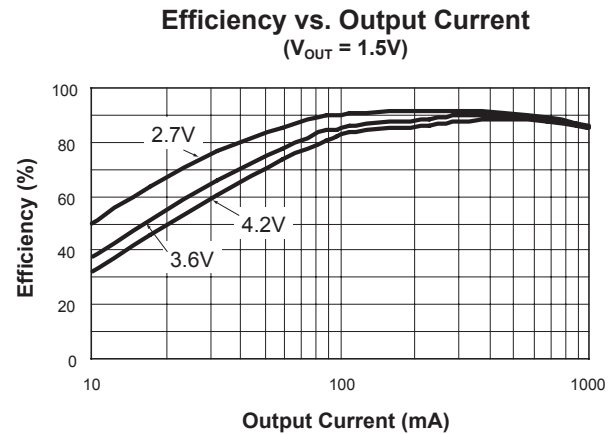
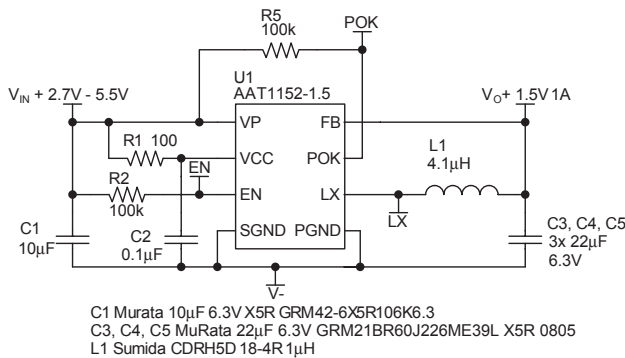

Figure 4: Lithium-Ion to 1.5V Output Converter.

Power Good

The AAT1152 features an integrated POK comparator and open-drain output signal. The POK pin goes low when the converter output is 12% or more below its nominal regulation voltage or when the device is in shutdown. Connect a pull-up resistor from POK to the converter input or output. Typical resistor pull-up values range from 100k to 10k.

Inductor

The output inductor is selected to limit the ripple current to some predetermined value, typically 20% to 40% of the full load current at the maximum input

voltage. Manufacturer's specifications list both the inductor DC current rating, which is a thermal limitation, and the peak current rating, which is determined by the saturation characteristics. The inductor should not show any appreciable saturation under normal load conditions. During overload and short-circuit conditions, the average current in the inductor can meet or exceed the I_{LIMIT} point of the AAT1152 without affecting converter performance. Some inductors may have sufficient peak and average current ratings yet result in excessive losses due to a high DCR. Always consider the losses associated with the DCR and its effect on the total converter efficiency when selecting an inductor.

For a 1A load and the ripple set to 30% at the maximum input voltage, the maximum peak-to-peak ripple current is 300mA. The inductance value required is 3.9μH.

$$L = \frac{V_{OUT}}{I_O \cdot k \cdot F_S} \cdot \left(1 - \frac{V_{OUT}}{V_{IN}}\right)$$

$$L = \frac{1.5V}{1.0A \cdot 0.3 \cdot 830kHz} \cdot \left(1 - \frac{1.5V}{4.2V}\right)$$

$$L = 3.9\mu H$$

The factor "k" is the fraction of full load selected for the ripple current at the maximum input voltage. The corresponding inductor RMS current is:

$$I_{RMS} = \sqrt{\left(I_O^2 + \frac{\Delta I^2}{12}\right)} \approx I_O = 1A$$

ΔI is the peak-to-peak ripple current which is fixed by the inductor selection above. For a peak-to-peak current of 30% of the full load current, the peak current at full load will be 115% of the full load. The 4.1μH inductor selected from the Sumida CDRH5D18 series has a 57mΩ DCR and a 1.95A DC current rating. At full load, the inductor DC loss is 57mW, which amounts to a 3.8% loss in efficiency.

Input Capacitor

The primary function of the input capacitor is to provide a low impedance loop for the edges of pulsed current drawn by the AAT1152. A low ESR/ESL ceramic capacitor is ideal for this function. To minimize the stray inductance, the capacitor should be placed as closely as possible to the IC. This keeps the high frequency content of the input current localized, minimizing radiated and conducted EMI while facilitating optimum performance of the AAT1152. Ceramic X5R or X7R capacitors are ideal for this function. The size required will vary depending on the load, output voltage, and input voltage source impedance characteristics. A typical value is around 10μF. The input capacitor RMS current varies with the input voltage and output voltage. The equation for the RMS current in the input capacitor is:

$$I_{RMS} = I_O \cdot \sqrt{\frac{V_O}{V_{IN}} \cdot \left(1 - \frac{V_O}{V_{IN}}\right)}$$

The input capacitor RMS ripple current reaches a maximum when V_{IN} is two times the output voltage where it is approximately one half of the load current. Losses associated with the input ceramic capacitor are typically minimal and are not an issue. Proper placement of the input capacitor can be seen in the reference design layout in Figures 5 and 6.

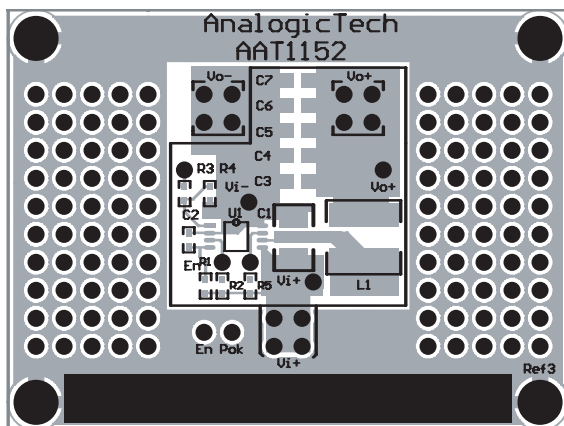

Figure 5: AAT1152 Evaluation Board Layout Top Layer.

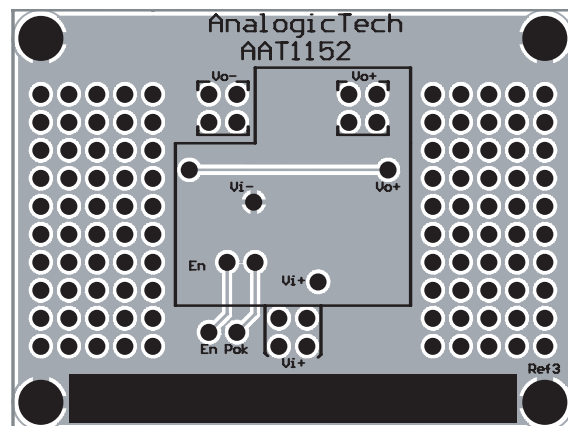

Figure 6: AAT1152 Evaluation Board Layout Bottom Layer.

Output Capacitor

Since there are no external compensation components, the output capacitor has a strong effect on loop stability. Larger output capacitance will reduce the crossover frequency with greater phase margin. For the 1.5V 1A design using the 4.1μH inductor, three 22μF 6.3V X5R capacitors provide a stable output. In addition to assisting stability, the output capacitor limits the output ripple and provides holdup during large load transitions. The output capacitor RMS ripple current is given by:

$$I_{\text{RMS}} = \frac{1}{2 \cdot \sqrt{3}} \cdot \frac{V_{\text{OUT}} \cdot (V_{\text{IN}} - V_{\text{OUT}})}{L \cdot F_{\text{S}} \cdot V_{\text{IN}}}$$

For a ceramic capacitor, dissipation due to the RMS current of the capacitor is not a concern. Tantalum capacitors with sufficiently low ESR to meet output voltage ripple requirements also have an RMS current rating much greater than that actually seen in this application.

Adjustable Output

For applications requiring an output other than the fixed outputs available, the 1V version can be externally programmed. Resistors R3 and R4 of Figure 3 force the output to regulate higher than 1V. R4 should be 100 times less than the internal 1MΩ resistance of the FB pin. Once R4 is selected, R3 can be calculated. For a 1.25V output with R4 set to 10.0kΩ, R3 is 2.55kΩ.

$$R3 = (V_{\text{O}} - 1) \cdot R4 = 0.25 \cdot 10.0\text{k}\Omega = 2.55\text{k}\Omega$$

Layout Considerations

Figures 5 and 6 display the suggested PCB layout for the AAT1152. The most critical aspect of the layout is the placement of the input capacitor C1. For proper operation, C1 must be placed as closely as possible to the AAT1152.

Thermal Calculations

There are two types of losses associated with the AAT1152 output switching MOSFET: switching losses and conduction losses. Conduction losses are associated with the $R_{\text{DS(ON)}}$ characteristics of the output switching device. At full load, assuming continuous conduction mode (CCM), a simplified form of the total losses is:

$$P_{\text{LOSS}} = \frac{I_{\text{O}}^2 \cdot (R_{\text{DS(ON)H}} \cdot V_{\text{O}} + R_{\text{DS(ON)L}} \cdot (V_{\text{IN}} - V_{\text{O}}))}{V_{\text{IN}}} + t_{\text{sw}} \cdot F_{\text{S}} \cdot I_{\text{O}} \cdot V_{\text{IN}} + I_{\text{Q}} \cdot V_{\text{IN}}$$

Once the total losses have been determined, the junction temperature can be derived from the Θ_{JA} for the MSOP-8 package.

Design Example:

Specifications

I_{OUT}	1A
I_{RIPPLE}	30% of full load at max V_{IN}
V_{OUT}	1.5V
V_{IN}	2.7V to 4.2V (3.6V nominal)
F_s	830kHz

Maximum Input Capacitor Ripple:

$$I_{RMS} = I_o \cdot \sqrt{\frac{V_o}{V_{IN}} \cdot \left(1 - \frac{V_o}{V_{IN}}\right)} = \frac{I_o}{2} = 0.5A_{RMS}, V_{IN} = 2 \cdot V_o$$

$$P = ESR_{COUT} \cdot I_{RMS}^2 = 5m\Omega \cdot 0.5^2A = 1.25mW$$

Inductor Selection:

$$L = \frac{V_{OUT}}{I_o \cdot K \cdot F_s} \cdot \left(1 - \frac{V_{OUT}}{V_{IN}}\right) = \frac{1.5V}{1A \cdot 0.3 \cdot 830kHz} \cdot \left(1 - \frac{1.5V}{4.2V}\right) = 3.9\mu H$$

Select Sumida Inductor CDRH5D18 4.1 μ H 57m Ω 2.0mm height.

$$\Delta I = \frac{V_o}{L \cdot F_s} \cdot \left(1 - \frac{V_o}{V_{IN}}\right) = \frac{1.5V}{4.1\mu H \cdot 830kHz} \cdot \left(1 - \frac{1.5V}{4.2V}\right) = 280mA$$

$$I_{PK} = I_{OUT} + \frac{\Delta I}{2} = 1A + 0.14A = 1.14A$$

$$P = I_o^2 \cdot DCR = 57mW$$

Output Capacitor Dissipation:

$$I_{RMS} = \frac{1}{2 \cdot \sqrt{3}} \cdot \frac{V_{OUT} \cdot (V_{IN} - V_{OUT})}{L \cdot F_s \cdot V_{IN}} = \frac{1}{2 \cdot \sqrt{3}} \cdot \frac{1.5V \cdot (4.2V - 1.5V)}{4.1\mu H \cdot 830kHz \cdot 4.2V} = 82mA_{RMS}$$

$$P_{ESR} = ESR_{COUT} \cdot I_{RMS}^2 = 5m\Omega \cdot 0.082^2A = 33\mu W$$

AAT1152 Dissipation:

$$P = \frac{I_O^2 \cdot (R_{DS(ON)H} \cdot V_O + R_{DS(ON)L} \cdot (V_{IN} - V_O))}{V_{IN}} + (t_{sw} \cdot F_s \cdot I_O + I_Q) \cdot V_{IN}$$

$$= \frac{(0.14\Omega \cdot 1.5V + 0.145\Omega \cdot (3.6V - 1.5V))}{3.6V} + (20ns \cdot 830kHz \cdot 1.0A + 0.3mA) \cdot 3.6V = 0.203W$$

$$T_{J(MAX)} = T_{AMB} + \Theta_{JA} \cdot P_{LOSS} = 85^\circ C + 150^\circ C/W \cdot 0.203W = 115^\circ C$$

Manufacturer	Part Number	Value	Max DC Current	DCR	Size (mm) L x W x H	Type
TaiyoYuden	NPO5DB4R7M	4.7μH	1.4A	0.038	5.9 x 6.1 x 2.8	Shielded
Toko	A914BYW-3R5M-D52LC	3.5μH	1.34A	0.073	5.0 x 5.0 x 2.0	Shielded
Sumida	CDRH5D28-4R2	4.2μH	2.2A	0.031	5.7 x 5.7 x 3.0	Shielded
Sumida	CDRH5D18-4R1	4.1μH	1.95A	0.057	5.7 x 5.7 x 2.0	Shielded
MuRata	LQH55DN4R7M03	4.7μH	2.7A	0.041	5.0 x 5.0 x 4.7	Non-Shielded
MuRata	LQH66SN4R7M03	4.7μH	2.2A	0.025	6.3 x 6.3 x 4.7	Shielded

Table 1: Surface Mount Inductors.

Manufacturer	Part Number	Value	Voltage	Temp. Co.	Case
MuRata	GRM40 X5R 106K 6.3	10μF	6.3V	X5R	0805
MuRata	GRM42-6 X5R 106K 6.3	10μF	6.3V	X5R	1206
MuRata	GRM21BR60J226ME39L	22μF	6.3V	X5R	0805
MuRata	GRM21BR60J106ME39L	10μF	6.3V	X5R	0805

Table 2: Surface Mount Capacitors.

Ordering Information

Output Voltage ¹	Package	Marking ²	Part Number (Tape and Reel) ³
1.0V (Adj. $V_{OUT} \geq 1.0V$)	MSOP-8	LTXYY	AAT1152IKS-1.0-T1
1.8V	MSOP-8	MLXYY	AAT1152IKS-1.8-T1
2.5V	MSOP-8	MMXYY	AAT1152IKS-2.5-T1
3.3V	MSOP-8	IAXYY	AAT1152IKS-3.3-T1



All AnalogicTech products are offered in Pb-free packaging. The term “Pb-free” means semiconductor products that are in compliance with current RoHS standards, including the requirement that lead not exceed 0.1% by weight in homogeneous materials. For more information, please visit our website at <http://www.analogictech.com/pbfree>.

Package Information

MSOP-8

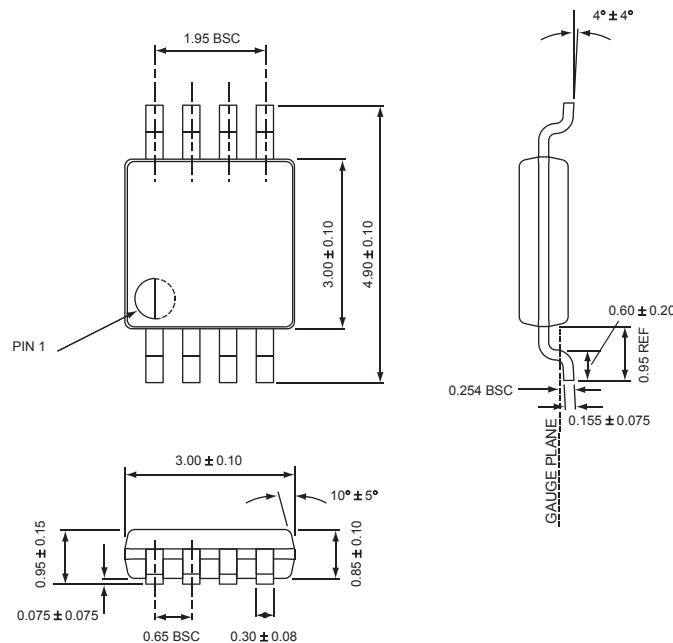

All dimensions in millimeters.

1. Contact Sales for other voltage options.
2. XYY = assembly and date code.
3. Sample stock is generally held on part numbers listed in **BOLD**.

© Advanced Analogic Technologies, Inc.

AnalogicTech cannot assume responsibility for use of any circuitry other than circuitry entirely embodied in an AnalogicTech product. No circuit patent licenses, copyrights, mask work rights, or other intellectual property rights are implied. AnalogicTech reserves the right to make changes to their products or specifications or to discontinue any product or service without notice. Customers are advised to obtain the latest version of relevant information to verify, before placing orders, that information being relied on is current and complete. All products are sold subject to the terms and conditions of sale supplied at the time of order acknowledgement, including those pertaining to warranty, patent infringement, and limitation of liability. AnalogicTech warrants performance of its semiconductor products to the specifications applicable at the time of sale in accordance with AnalogicTech's standard warranty. Testing and other quality control techniques are utilized to the extent AnalogicTech deems necessary to support this warranty. Specific testing of all parameters of each device is not necessarily performed.

AnalogicTech and the AnalogicTech logo are trademarks of Advanced Analogic Technologies Incorporated. All other brand and product names appearing in this document are registered trademarks or trademarks of their respective holders.

Advanced Analogic Technologies, Inc.
830 E. Arques Avenue, Sunnyvale, CA 94085
Phone (408) 737-4600
Fax (408) 737-4611