

PLEASE CHECK WWW.MOLEX.COM FOR LATEST PART INFORMATION

Part Number: [0330013023](#)
Status: **Active**
Overview: [mx150 sealed connector system](#)
Description: MX150™ Female Terminal, Select Gold (Au) Plating, 22 AWG, Left Reel Payoff, Large Polarization Rib, Contact Material Thickness 0.30mm (.012")

Documents:

[Drawing \(PDF\)](#) [RoHS Certificate of Compliance \(PDF\)](#)

General

Product Family	Crimp Terminals
Series	33001
Comments	Left Reel Payoff, Large Polarization Rib
Crimp Quality Equipment	Yes
Overview	mx150 sealed connector system
Product Name	MX150™

Physical

Gender	Female
Material - Metal	High Performance Alloy (HPA)
Material - Plating Mating	Unplated
Material - Plating Termination	Unplated
Packaging Type	Reel
Plating min: Mating (µin)	30.4
Plating min: Mating (µm)	0.76
Plating min: Termination (µin)	100
Plating min: Termination (µm)	2.5
Termination Interface: Style	Crimp or Compression
Wire Insulation Diameter	2.60mm (.102") max.
Wire Size AWG	22
Wire Size mm²	0.5

Electrical

Current - Maximum per Contact	22A
Voltage - Maximum	250V

Material Info

Reference - Drawing Numbers

Sales Drawing	SD-33012-002
---------------	--------------

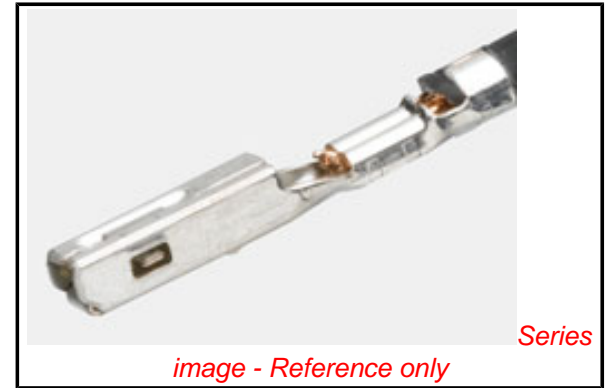

EU RoHS

**ELV and RoHS
Compliant**
**REACH SVHC
Contains SVHC: No**
**Halogen-Free
Status**

China RoHS



Not Reviewed

Need more information on product environmental compliance?

Email productcompliance@molex.com
 For a multiple part number RoHS Certificate of Compliance, [click here](#)

Please visit the [Contact Us](#) section for any non-product compliance questions.

Search Parts in this Series

[33001Series](#)

Use With

[33472](#) Dual Row Housing, [33476](#) Hybrid Housing, [33471](#) Single Row Housing

Application Tooling | FAQ

Tooling specifications and manuals are found by selecting the products below. Crimp Height Specifications are then contained in the Application Tooling Specification document.

Global

Description	Product #
Manual Extraction Tool	0638131500
FineAdjust™ Applicator	0639001000
Hand Crimp Tool, 18-22AWG	0638116000
Hand Crimp Tool, Metric 0.05 and 0.75	0638116200

This document was generated on 05/27/2010

PLEASE CHECK WWW.MOLEX.COM FOR LATEST PART INFORMATION

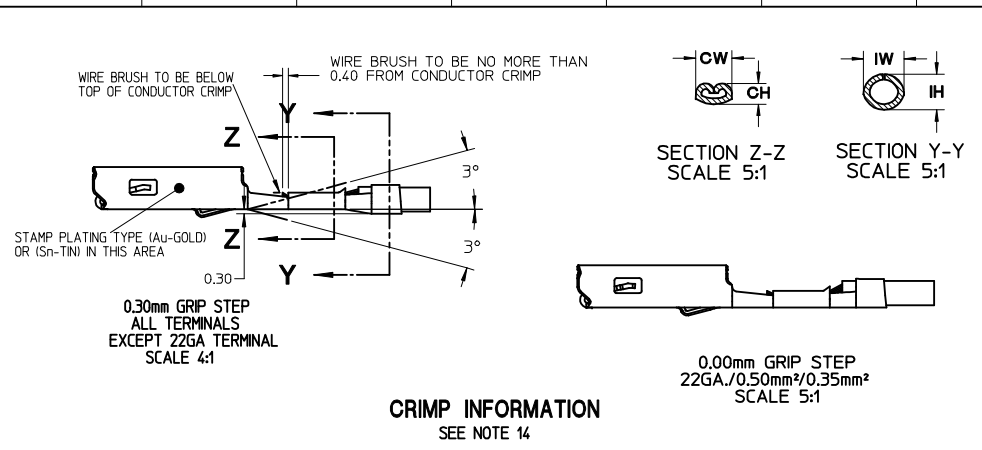

CRIMP INFORMATION
SEE NOTE 14

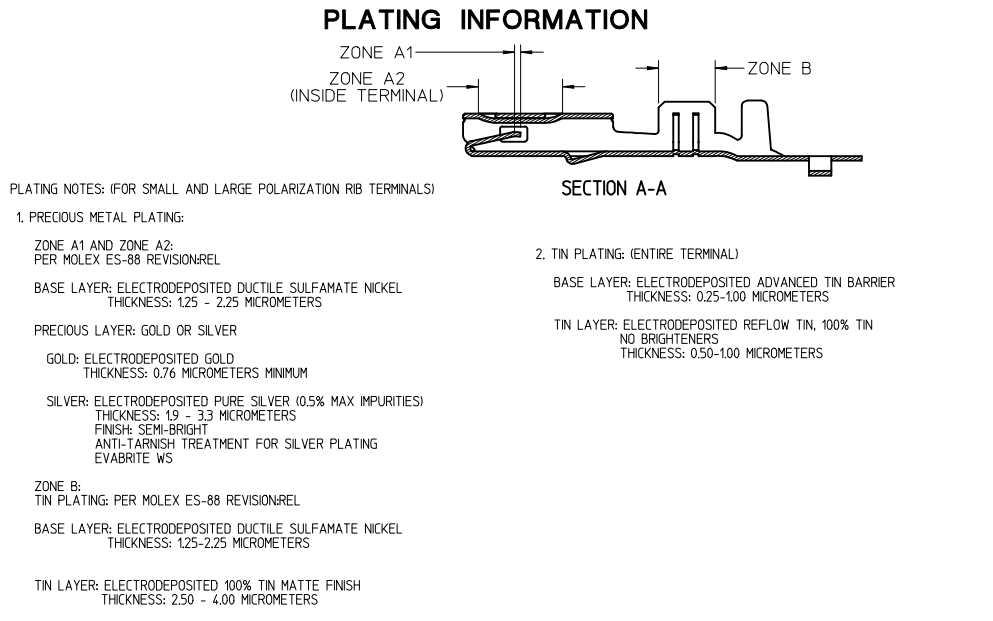

PLATING INFORMATION

PLATING NOTES: (FOR SMALL AND LARGE POLARIZATION RIB TERMINALS)

- PRECIOUS METAL PLATING:
ZONE A1 AND ZONE A2:
PER MOLEX ES-88 REVISION REL
BASE LAYER: ELECTRODEPOSITED DUCTILE SULFAMATE NICKEL
THICKNESS: 125 - 225 MICROMETERS
PRECIOUS LAYER: GOLD OR SILVER
GOLD: ELECTRODEPOSITED GOLD
THICKNESS: 0.76 MICROMETERS MINIMUM
SILVER: ELECTRODEPOSITED PURE SILVER (0.5% MAX IMPURITIES)
THICKNESS: 19 - 33 MICROMETERS
FINISH: SEMI-BRIGHT
ANTI-TARNISH TREATMENT FOR SILVER PLATING
EVABRITE WS
 - TIN PLATING: (ENTIRE TERMINAL)
BASE LAYER: ELECTRODEPOSITED ADVANCED TIN BARRIER
THICKNESS: 0.25-1.00 MICROMETERS
TIN LAYER: ELECTRODEPOSITED REFLOW TIN, 100% TIN
NO BRIGHTENERS
THICKNESS: 0.50-1.00 MICROMETERS
- ZONE B:
TIN PLATING: PER MOLEX ES-88 REVISION REL
BASE LAYER: ELECTRODEPOSITED DUCTILE SULFAMATE NICKEL
THICKNESS: 125-225 MICROMETERS
TIN LAYER: ELECTRODEPOSITED 100% TIN MATTE FINISH
THICKNESS: 2.50 - 4.00 MICROMETERS

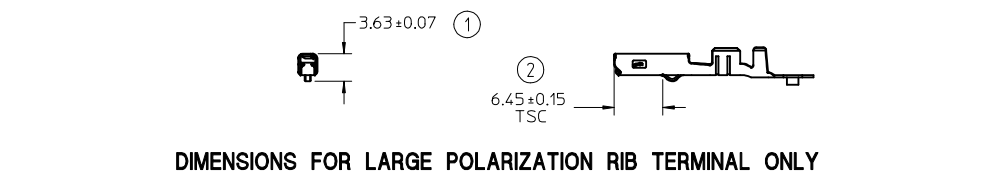

DIMENSIONS FOR LARGE POLARIZATION RIB TERMINAL ONLY

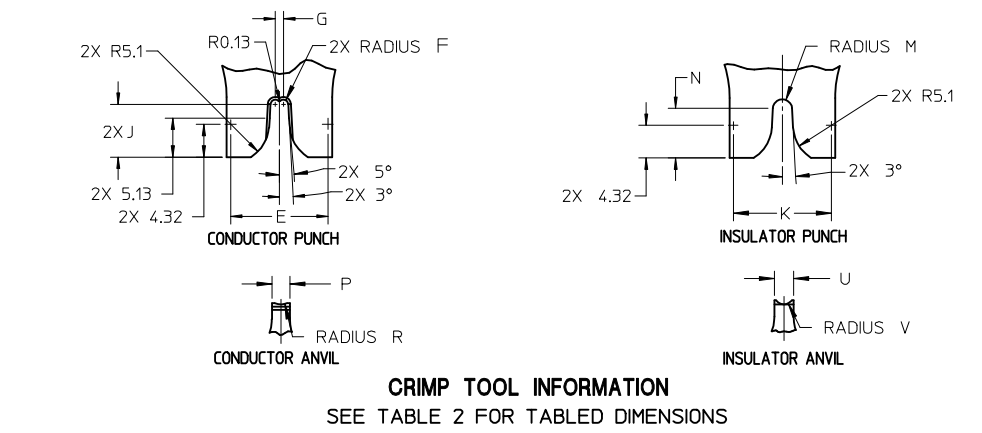

CRIMP TOOL INFORMATION
SEE TABLE 2 FOR TABLED DIMENSIONS

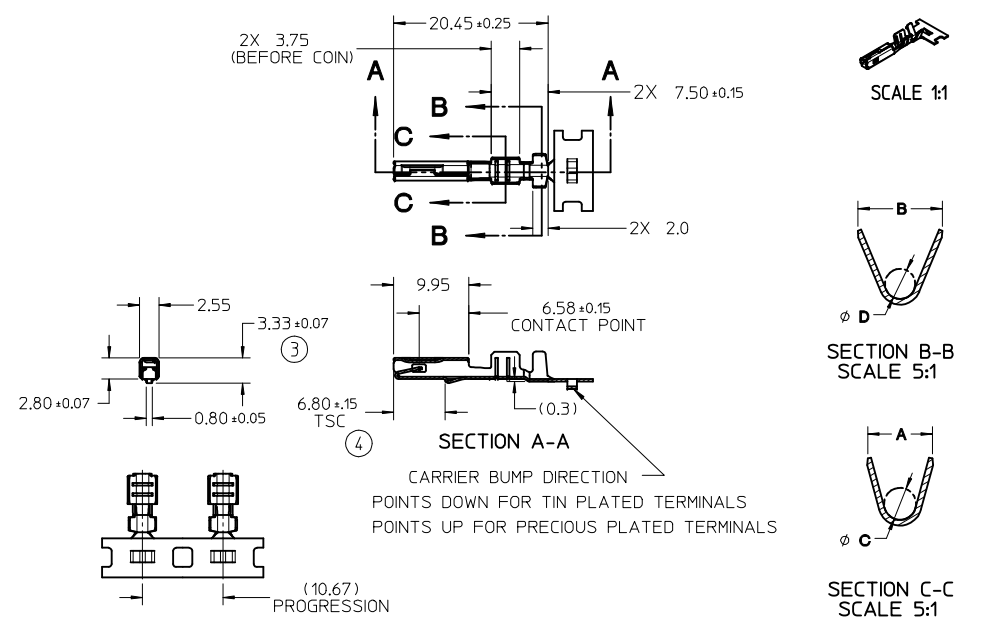

- NOTES: (UNLESS OTHERWISE SPECIFIED)
- MATING TERMINAL SHOWN ON SD-33000-001
 - MATERIAL: ASTM B422, UNS C19025, HR04
THICKNESS: 0.30 mm ±0.01
TEMPER: FULL HARD (REF)
TENSILE: 496 MIN MPA
PLATING: SEE PLATING NOTES ABOVE
 - MEETS PERFORMANCE SPECIFICATION FOR CABLE TO TERMINAL ELECTRICAL CRIMPS PER SAE/USCAR-21 (8/2001)
 - MEETS PERFORMANCE STANDARD FOR AUTOMOTIVE ELECTRICAL CONNECTOR SYSTEMS FOR SAE/USCAR-2, REV. 4 (TEMP CLASS 3) (4/2001)
 - MEETS ELECTRICAL CONNECTION SYSTEM DESIGN SPECIFICATION (SDS) REV.11 (5/2002)
 - MEETS FIELD CORRELATED LIFE TEST (FCLT) PER SAE/USCAR-20 (11/2001)
 - MEETS WIRING COMPONENT DESIGN GUIDELINES SAE/USCAR-12 REV 2 (12/2001)
 - TSC ON A DIMENSION TO BE INTERPRETED AS DISTANCE TO A THEORETICAL SHARP CORNER AS IF THE RADIUS WERE NOT PRESENT
 - DRAWING CONFORMS TO AVP-(T401/T406)-001 REVISION A DATED 2/16/99
 - REFERENCE 97B5-14474-AAB FOR LARGE POLARIZATION RIB CAVITY SPECIFICATION
 - INSERTION FORCE (TIN) AVG. FROM PV TESTING =
3.8N LARGE POLARIZATION RIB
3.5N SMALL POLARIZATION RIB (REFERENCE)
 - ALL DIMENSIONS EXCEPT ①, ②, ③ & ④ ARE COMMON TO BOTH SMALL AND LARGE POLARIZATION RIB TERMINALS
 - REFERENCE PK-31300-516 FOR REEL DIRECTION
 - REFERENCE CS-33012-002 FOR ADDITIONAL CRIMP INFORMATION

ENTER DESCRIPTION EC NO: UAU2010-0107 DRAWN BY: DRWINKFERGUSON CHKD: A. DHIR APPR: B. MOSER 2009/08/19 2009/08/20	QUALITY SYMBOLS ▽=0 ▽=0	GENERAL TOLERANCES (UNLESS SPECIFIED)		DIMENSION STYLE MM ONLY		SCALE 2:1	DESIGN UNITS METRIC	THIRD ANGLE PROJECTION	
		mm	INCH	DRAWN BY L. PULLIAM	DATE 2005/06/21	TITLE MX150 RECEPTACLE TERMINAL			
B1	REV	4 PLACES	± .005	± .005	CHECKED BY A. DHIR	DATE 2005/06/21	MOLEX MOLEX INCORPORATED		
		3 PLACES	± 0.10	± 0.10	APPROVED BY B. MOSER	DATE 2005/06/22			
		2 PLACES	± 0.3	± 0.3	MATERIAL NO. SEE TABLE		DOCUMENT NO. SD-33012-002	SHEET NO. 1 OF 5	
		1 PLACE	± 3°	± 3°	THIS DRAWING CONTAINS INFORMATION THAT IS PROPRIETARY TO MOLEX INCORPORATED AND SHOULD NOT BE USED WITHOUT WRITTEN PERMISSION				

TABLE 1 - TERMINAL CRIMP DIM. REFERENCE 9

J	SUPPLIER PART NO.		FORD PART NO.	PLATING	WIRE SIZE (awg)	WIRE SPECIFICATION	CONDUCTOR CH (SEC Z-Z) ±0.05 mm		CONDUCTOR CW (SEC Z-Z) ±0.10 mm		INSULATOR IH (SEC Y-Y) ±0.10 mm		INSULATOR IW (SEC Y-Y) ±0.10 mm		WIRE PULL FORCE (N)	
	RIGHT PAYOFF	LEFT PAYOFF					CH	CW	IH	IW						
I	SMALL POLARIZATION RIB															
	33012-2001	33012-3001	7C3T-14474-EA	TIN	14	ML-123A	1.65	2.45	2.90	2.75	2.68					
H	LARGE POLARIZATION RIB															
	33001-4023*	33001-5023*	7U5T-14474-NA	SILVER**	0.50mm ²	JASO D 611 (AVSS)	1.60	2.45	2.90	2.75	2.31	ML-126A1	1.10	1.60	1.80	1.90

RIGHT PAYOFF	LEFT PAYOFF	7U5T-14474-NA	SILVER**	0.50mm ²	ML-126A1	1.10	1.60	1.80	1.90	1.11
33001-4023*	33001-5023*	7U5T-14474-NA*	SILVER**	0.35mm ²	WSK-1A348-A2	0.95	1.60	1.70	1.90	50

¹HFILON WIRE:
CORE WIRE: STAINLESS STEEL, SUS #0.14, 7 STRANDS
SURROUNDING WIRE: NICKEL (Ni) PLATED COPPER (Cu) #0.14, 30 STRANDS
INSULATOR: PTFE

* 0.35mm² WIRE MUST NOT BE USED IN MX150 SEALED CONNECTOR SYSTEMS

** SILVER PLATED TERMINALS NOT TO BE USED IN CONNECTOR SYSTEMS WITH CIRCUIT COUNTS HIGHER THAN 8 DUE TO HIGHER CONNECTOR MATE/UNMATE FORCE

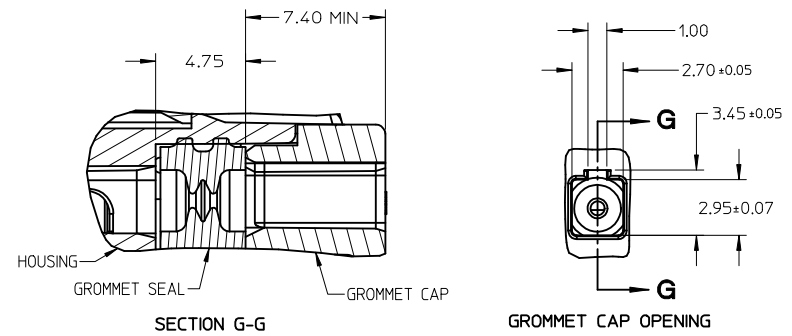

GROMMET SEAL / CAP CONFIGURATION TO MODIFY LARGE POLARIZATION RIB CAVITY TO ACCEPT SMALL POLARIZATION RIB APPLICATIONS

ENTER DESCRIPTION EC NO: UAU2010-0107 DRINKWATERGUSON 2009/08/18 CHKDA-DHIR 2009/08/19 APPR:BMOSER 2009/08/20	QUALITY SYMBOLS ▽=0 ▽=0	GENERAL TOLERANCES (UNLESS SPECIFIED)		DIMENSION STYLE MM ONLY		SCALE	DESIGN UNITS	THIRD ANGLE PROJECTION					
		4 PLACES ± --- ± --- 3 PLACES ± 0.005 ± --- 2 PLACES ± 0.10 ± --- 1 PLACE ± 0.3 ± ---	mm INCH ± --- ± --- ± 0.005 ± --- ± 0.10 ± --- ± 0.3 ± ---	DRAWN BY L. PULLIAM 2005/06/21	DATE 2005/06/21	TITLE	MX150 RECEPTACLE TERMINAL						
REV B1		ANGULAR ± 3°		APPROVED BY B. MOSER 2005/06/22		DATE 2005/06/22		MATERIAL NO. SEE TABLE		DOCUMENT NO. SD-33012-002		SHEET NO. 2 OF 5	
THIS DRAWING CONTAINS INFORMATION THAT IS PROPRIETARY TO MOLEX INCORPORATED AND SHOULD NOT BE USED WITHOUT WRITTEN PERMISSION													

THIS CHECKING - AID IS FOR SMALL POLARIZATION RIB TERMINALS ONLY

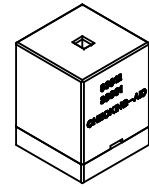

CHECKING - AID ASSEMBLY
SCALE 1:1

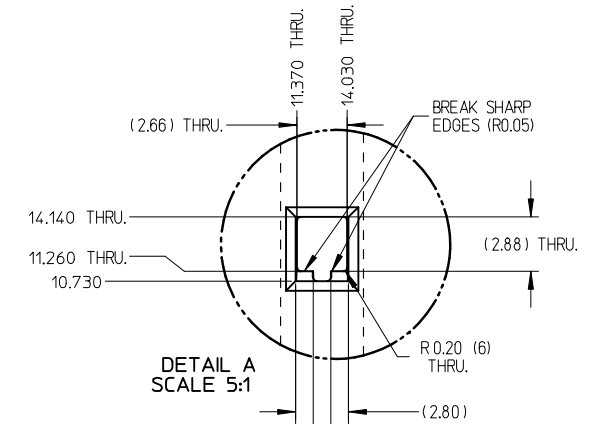

DETAIL A
SCALE 5:1

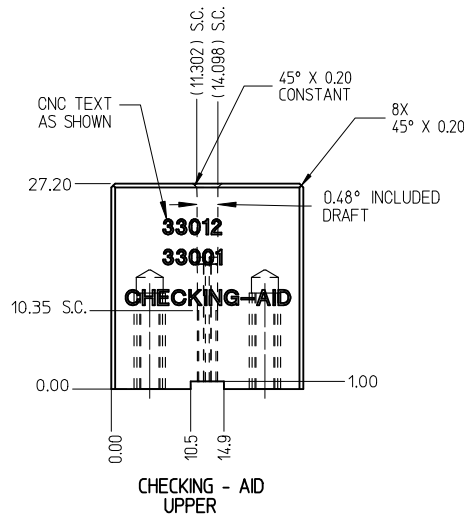
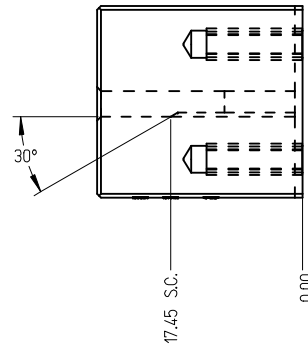
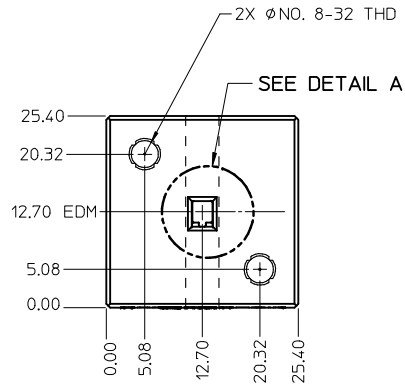

CHECKING - AID
UPPER

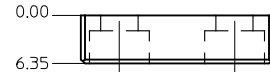
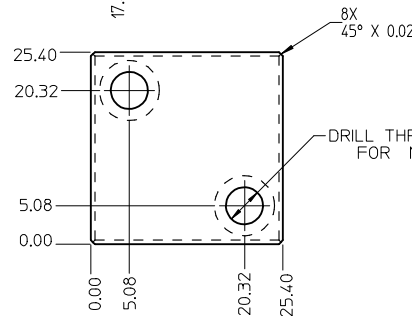

CHECKING - AID
LOWER

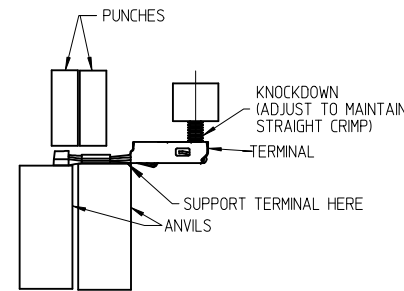

CRIMP REQUIREMENTS:

1. CRIMP STRAIGHTNESS MUST BE MAINTAINED
USE A KNOCKDOWN TOOL LOCATED AS SHOWN
TERMINAL BOX MUST NOT BE DEFORMED
2. AFTER CRIMPING, THE CRIMPED TERMINAL (AND UP TO 5 mm OF WIRE PAST THE INSULATOR CUTOFF TAB) MUST FIT FREELY INTO THE CHECKING-AID SHOWN ON THIS PAGE
3. FOR OTHER MECHANICAL REQUIREMENTS ON CRIMPED TERMINALS, REFER TO SAE/USCAR-21 (5-13-02) SECTIONS 4.2 (VISUAL INSPECTION), 4.2 (CROSS SECTION ANALYSIS) AND 4.4 (CONDUCTOR CRIMP PULLOUT FORCE)

UPPER & LOWER
CHECKING-AID
A2 TOOL STEEL
HARDEN & GRIND
ROCKWELL "C" 56-58

ENTER DESCRIPTION EC NO: UAU2010-0107 DRINKFERGUSON 2009/08/18 CHKDA:DHIR 2009/08/19 APPR:BMOSER 2009/08/20	QUALITY SYMBOLS ▽=0 ▽=0	GENERAL TOLERANCES (UNLESS SPECIFIED)		DIMENSION STYLE MM ONLY	SCALE 2:1	DESIGN UNITS METRIC	THIRD ANGLE PROJECTION	
		4 PLACES ± mm 3 PLACES ± 0.005 2 PLACES ± 0.10 1 PLACE ± 0.3	INCH ± --- ± --- ± --- ± ---	DRAWN BY L. PULLIAM	DATE 2005/06/21	CHECKED BY A. DHIR	DATE 2005/06/21	MX150 RECEPTACLE TERMINAL
APPROVED BY B. MOSER	DATE 2005/06/22	MATERIAL NO. SEE TABLE		DOCUMENT NO. SD-33012-002		MOLEX INCORPORATED		
REV B1	SIZE C	THIS DRAWING CONTAINS INFORMATION THAT IS PROPRIETARY TO MOLEX INCORPORATED AND SHOULD NOT BE USED WITHOUT WRITTEN PERMISSION						SHEET NO. 3 OF 5

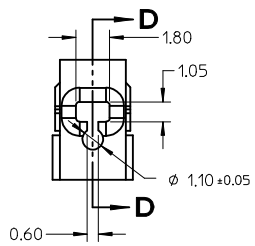
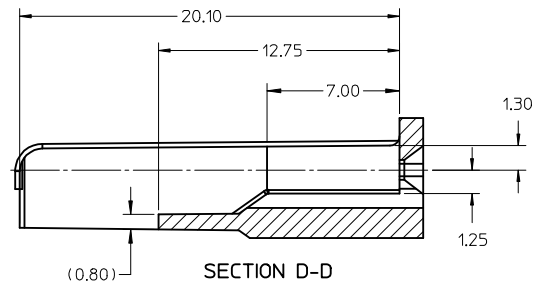
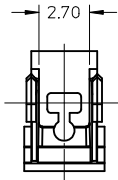

- NOTES: UNLESS OTHERWISE SPECIFIED
1. TOLERANCES: LINEAR ± 0.10
ANGULAR $\pm 3^\circ$
 2. ALL DRAFT WITHIN TOLERANCE.
 3. MAX RADII ON ALL CORNERS SHOWN SHARP: 0.10
 4. MAX FLASH PERMISSIBLE: 0.1
 5. EJECTOR PIN MARKS PERMISSIBLE IF FLUSH TO 0.25 BELOW SURFACE.
 6. MATERIAL: HOUSING/FINGER SPECIFICATION ENGINEERED FOR MATERIAL WITH THE FOLLOWING PROPERTIES:
A. FLEXURAL MODULUS = 4,500 TO 9,400 MPa
PER ASTM TEST D790
B. ELONGATION AT YIELD = 2.3% OR BETTER
PER ASTM TEST D638 TYPE V
 7. CAVITY SPEC FOR USE ONLY WITH MOLEX RECEPTACLE
TERMINAL PART NUMBERS SPECIFIED ELSEWHERE ON THIS
DRAWING

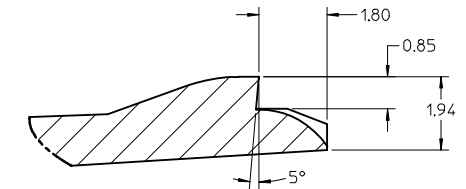
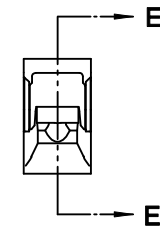
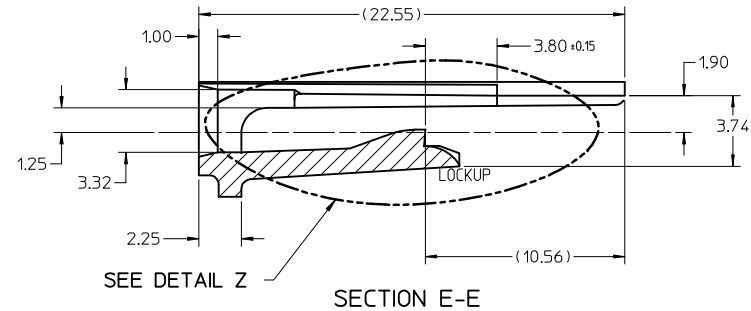
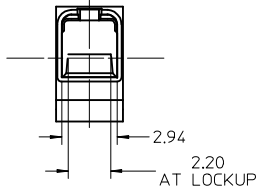

DETAIL Z
SCALE 20:1

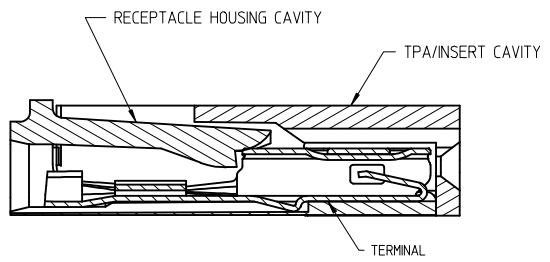

SECTION F-F

RECEPTACLE CAVITY ASSEMBLED VIEWS
FOR SMALL POLARIZATION RIB APPLICATIONS
FIG. 1

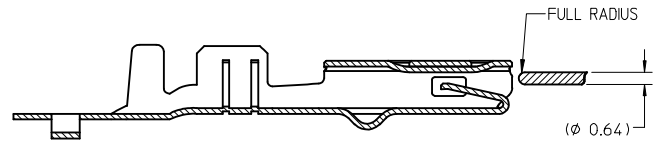
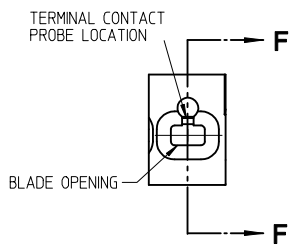

SECTION D-D
FOR LARGE POLARIZATION RIB APPLICATIONS
FIG. 2

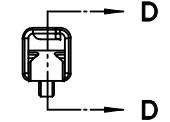

PROBING DOWN THE
THROAT MUST USE
THIS TERMINAL PROBE

PROBE PIN DETAILS:
MANUFACTURER: LONE STAR INDUSTRIAL
PART NUMBER: LS054R-403-N-4.6
PIN DIAMETER: 0.025 IN (0.64mm)
TIP SHAPE: SPHERICAL
TEL: 915-779-7255

PREFERRED PROBING LOCATION
IS NOT ON SPRING MEMBER

IF ELECTRICAL CONTINUITY PROBE
TOUCHES SPRING MEMBER USE
PROBING AS SHOWN IN FIG. 2

REV	DESCRIPTION	DATE	BY
B1	ENTER DESCRIPTION	2009/08/18	DRWIN:KEERGUSON
	EC NO: UAU2010-0107	2009/08/19	CHKD:A.DHIR
	APPR:BMOSER	2009/08/20	

QUALITY SYMBOLS
◀=0
▽=0

GENERAL TOLERANCES (UNLESS SPECIFIED)	
mm	INCH
4 PLACES ± 0.10	± 0.005
3 PLACES ± 0.005	± 0.0005
2 PLACES ± 0.10	± 0.005
1 PLACE ± 0.3	± 0.012
ANGULAR ± 3°	

DIMENSION STYLE	
MM ONLY	
DRAWN BY	DATE
L. PULLIAM	2005/06/21
CHECKED BY	DATE
A. DHIR	2005/06/21
APPROVED BY	DATE
B. MOSER	2005/06/22
MATERIAL NO.	
SEE TABLE	
SIZE	
C	

SCALE	DESIGN UNITS	THIRD ANGLE PROJECTION
5:1	METRIC	☉
MX150 RECEPTACLE TERMINAL		
MOLEX INCORPORATED		
DOCUMENT NO.	SHEET NO.	
SD-33012-002	4 OF 5	

THIS DRAWING CONTAINS INFORMATION THAT IS PROPRIETARY TO MOLEX INCORPORATED AND SHOULD NOT BE USED WITHOUT WRITTEN PERMISSION

