

**PLEASE CHECK WWW.MOLEX.COM FOR LATEST PART INFORMATION**

**Part Number:** [0039305049](#)

**Status:** **Active**

**Overview:** [Mini-Fit Jr.™](#)

**Description:** 4.20mm (.165") Pitch Mini-Fit Jr.™ Header, Single Row, Vertical, with Snap-in Plastic Peg PCB Lock, 4 Circuits, PA Polyamide Nylon 6/6, UL 94V-2, Tin (Sn) Over Nickel (Ni) Plating, with Drain Holes

**Documents:**

[3D Model](#)

[Drawing \(PDF\)](#)

[Product Specification PS-5556-001 \(PDF\)](#)

[RoHS Certificate of Compliance \(PDF\)](#)

**Agency Certification**

CSA	LR19980
TUV	R72081037
UL	E29179

**General**

Product Family	PCB Headers
Series	<a href="#">5566</a>
Application	Wire-to-Board
Comments	Current = 13A max. per circuit when header is mated to a receptacle loaded with <a href="#">45750</a> Mini-Fit Plus HCS™ Crimp Terminal Crimped to to 16 AWG wire. . See Molex product specification PS-45750-001 for additional current de-rating information.. High Temperature, Square Pin, Solder Type
Overview	<a href="#">Mini-Fit Jr.™</a>
Product Name	Mini-Fit Jr.™

**Physical**

Breakaway	No
Circuits (Loaded)	4
Circuits (maximum)	4
Color - Resin	Natural
Durability (mating cycles max)	30
First Mate / Last Break	No
Flammability	94V-2
Glow-Wire Compliant	No
Guide to Mating Part	No
Keying to Mating Part	None
Lock to Mating Part	Yes
Material - Metal	Brass
Material - Plating Mating	Tin
Material - Plating Termination	Tin
Material - Resin	Nylon
Number of Rows	1
Orientation	Vertical
PC Tail Length (in)	0.138 In
PC Tail Length (mm)	3.50 mm
PCB Locator	Yes
PCB Retention	Yes
PCB Thickness Recommended (in)	0.062 In
PCB Thickness Recommended (mm)	1.60 mm
Packaging Type	Tray
Pitch - Mating Interface (in)	0.165 In
Pitch - Mating Interface (mm)	4.20 mm

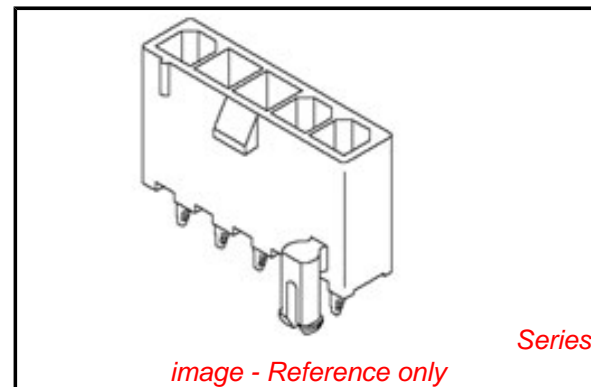

**EU RoHS**

**ELV and RoHS Compliant**

**REACH SVHC**

**Contains SVHC: No**

**Halogen-Free**

**Status**

**Not Reviewed**

**China RoHS**



**Need more information on product environmental compliance?**

Email [productcompliance@molex.com](mailto:productcompliance@molex.com)  
For a multiple part number RoHS Certificate of Compliance, [click here](#)

Please visit the [Contact Us](#) section for any non-product compliance questions.

**Search Parts in this Series**

[5566Series](#)

**Mates With**

[5557](#) Mini-Fit Jr.™ Receptacle Housing

Pitch - Term. Interface (in)	0.165 In
Pitch - Term. Interface (mm)	4.20 mm
Plating min: Mating (µin)	101.6
Plating min: Mating (µm)	2.54
Plating min: Termination (µin)	101.6
Plating min: Termination (µm)	2.54
Polarized to Mating Part	Yes
Polarized to PCB	Yes
Shrouded	Fully
Stackable	No
Surface Mount Compatible (SMC)	No
Temperature Range - Operating	-40°C to +105°C
Termination Interface: Style	Through Hole

### **Electrical**

Current - Maximum per Contact	13A
Voltage - Maximum	600V

### **Solder Process Data**

Duration at Max. Process Temperature (seconds)	5
Lead-free Process Capability	Wave Capable (TH only)
Max. Cycles at Max. Process Temperature	1
Process Temperature max. C	235

### **Material Info**

Old Part Number	5566-04B3S
-----------------	------------

### **Reference - Drawing Numbers**

Packaging Specification	PK-5566-002
Product Specification	PS-5556-001
Sales Drawing	SDA-5566-NL*
Test Summary	TS-5556-002

This document was generated on 05/12/2010

**PLEASE CHECK [WWW.MOLEX.COM](http://WWW.MOLEX.COM) FOR LATEST PART INFORMATION**

NOTES:

1. MATERIALS:

HOUSING:

\*BLANK\*=NYLON 6/6, UL94 V-2, COLOR: NATURAL

\*210\*=NYLON 6/6, UL94 V-0, COLOR: NATURAL

\*BL\*=NYLON 6/6, UL94 V-2, COLOR: BLACK

TERMINALS:

BRASS

2. TERMINAL PLATING:

\*BLANK\*=.000035/(0.00090) MIN. BRIGHT TIN OVER

.000020/(0.00050) MIN. COPPER

\*GS2=.000015/(0.00038) MIN. SELECT GOLD AND

.000100/(0.00254) MIN. SELECT MATTE TIN

OVER .000050/(0.00127) MIN. NICKEL OVERALL

\*GS=.000030/(0.00076) MIN. SELECT GOLD AND

.000100/(0.00254) MIN. SELECT MATTE TIN

OVER .000050/(0.00127) MIN. NICKEL OVERALL

S=.000100/(0.00254) MIN. BRIGHT TIN OVER

.000050/(0.00127) MIN. NICKEL

\*THE PRIMARY SHIPPING CARTON WILL BE LABELED

"ELV AND RoHS COMPLIANT", CARTONS WITHOUT

THIS LABEL MAY CONTAIN PRODUCT WITH

TIN-LEAD PLATING.

3. PRODUCT SPECIFICATION: PS-5556-001

4. PACKAGING: TRAY PACKED PER PK-5566-002

5. PART MATES WITH MINI-FIT JR. RECEPTACLE NO. 5557.

6. PART IS NOT DESIGNED FOR CURRENT SHARING.

7. PARTS ARE NOT TO BE MATED OR UN-MATED WHILE

CIRCUITS ARE LIVE.

8. PART CONFORMS TO CLASS "B" REQUIREMENTS OF

COSMETIC SPECIFICATION PS-45499-002.

CKT SIZE	DIM A	DIM B
4	.709 (18.00)	.496 (12.60)
5	.874 (22.20)	.661 (16.80)
6	1.039 (26.40)	.827 (21.00)
7	1.205 (30.60)	.992 (25.20)
8	1.370 (34.80)	1.157 (29.40)
9	1.535 (39.00)	1.323 (33.60)
10	1.701 (43.20)	1.488 (37.80)
11	1.866 (47.40)	1.654 (42.00)
12	2.031 (51.60)	1.819 (46.20)

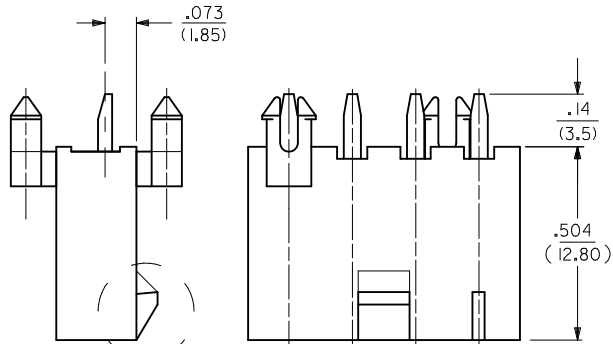
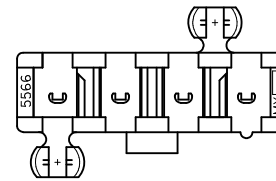

LOCK OPTION

POSITIVE LOCK      PASSIVE LOCK

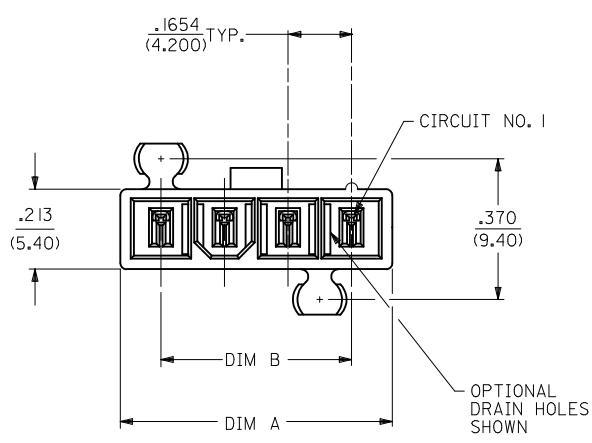

LEGEND:

5566 - N \* \* \* \* \*

CIRCUIT SIZE (04-12)

ASSEMBLY TYPE  
A=W/O DRAIN HOLES  
B=WITH DRAIN HOLES

PEG AND LOCK OPTION  
3=MTG. PEGS, POSITIVE LOCK  
4=MTG. PEGS, PASSIVE LOCK

PLATING (SEE NOTE 2)

HOUSING MAT'L (SEE NOTE 1)

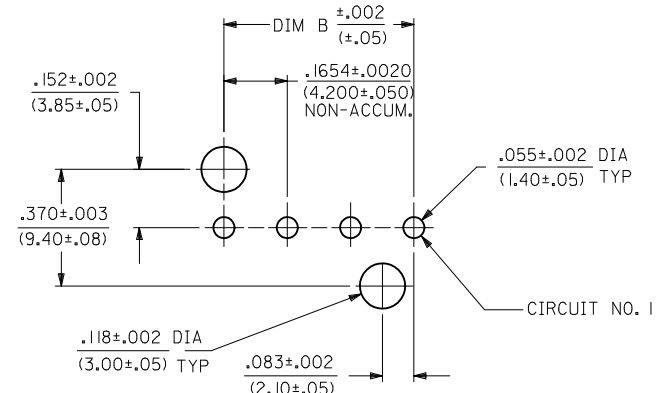

RECOMMENDED HOLE LAYOUT FOR .070/(1.78) MAX. THICK P. C. BOARD VIEWED FROM COMPONENT SIDE

4	M
3	M
2	K1
1	M
SHEET REV	

ADD PART #S EC NO: UCP2010-1922 DRWN: RBENES 2009/02/10 CHKD: BELL 2010/02/12 APPR: FSMITH 2010/02/15	QUALITY SYMBOLS ▽=0 ▽=0	GENERAL TOLERANCES (UNLESS SPECIFIED)	DIMENSION STYLE IN/MM	SCALE 1:1	DESIGN UNITS METRIC	THIRD ANGLE PROJECTION
		4 PLACES ± --- ± --- 3 PLACES ± --- ± .015 2 PLACES ± 0.38 ± --- 1 PLACE ± --- ± --- ANGULAR ± 1/2°	DRAWN BY KSS DATE 1989/02/19	CHECKED BY JTR DATE 1989/02/19	APPROVED BY RAS DATE 1989/02/19	TITLE VERTICAL HEADER ASSY W/ & W/O PEG & DRAIN HOLE MINI-FIT JR SINGLE ROW
DRAFT WHERE APPLICABLE MUST REMAIN WITHIN DIMENSIONS	MATERIAL NO. SEE CHART	DOCUMENT NO. SDA-5566-NL*	THIS DRAWING CONTAINS INFORMATION THAT IS PROPRIETARY TO MOLEX INCORPORATED AND SHOULD NOT BE USED WITHOUT WRITTEN PERMISSION			

