

PLEASE CHECK WWW.MOLEX.COM FOR LATEST PART INFORMATION

Part Number: [0196001306](#)
Status: **Active**
Description: Avikrimp™ Fully Insulated Female Quick Disconnect

Documents:

[Drawing \(PDF\)](#) [RoHS Certificate of Compliance \(PDF\)](#)

Agency Certification

CSA LR18689
 UL E79133

General

Product Family Quick Disconnects
 Series [19600](#)
 Crimp Quality Equipment Yes
 Product Name Avikrimp™
 Type Quick Disconnect

Physical

Barrel Type Closed
 Flammability 94V-2
 Gender Female
 Glow-Wire Compliant No
 Insulation Nylon (PA)
 Lock to Mating Part None
 Material - Metal Brass
 Orientation Straight
 Packaging Type Adhesive Tape on Reel
 Polarized to Mating Part No
 Tab Thickness 0.81mm (.032")
 Tab Width 6.35mm (.250")
 Temperature Range - Operating -65°C to +105°C
 Wire Insulation Diameter 6.89x4.32mm (.270x.170") max.
 Wire Size AWG 16+16, 18+18, 20+20, 22+22

Electrical

Voltage - Maximum 300V

Material Info

Reference - Drawing Numbers

Sales Drawing SD-19600-1300

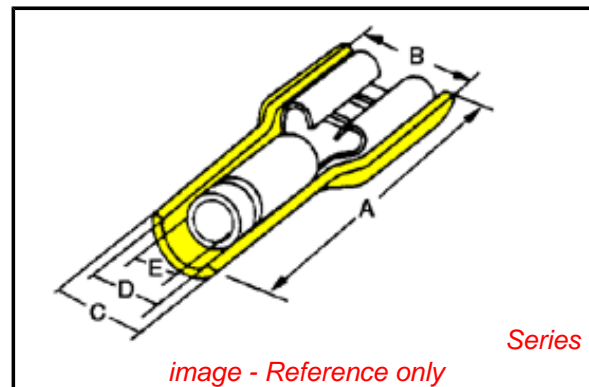

EU RoHS

ELV and RoHS Compliant

REACH SVHC

Not Reviewed

Halogen-Free

Status

Not Reviewed

China RoHS



Need more information on product environmental compliance?

Email productcompliance@molex.com
 For a multiple part number RoHS Certificate of Compliance, [click here](#)

Please visit the [Contact Us](#) section for any non-product compliance questions.

Search Parts in this Series

[19600Series](#)

Application Tooling | [FAQ](#)

Tooling specifications and manuals are found by selecting the products below. Crimp Height Specifications are then contained in the Application Tooling Specification document.

Global

Description	Product #
ATP Perishable Tool Kit used in ATP Presses that Process Product on Tape, for 2 Wires 18-22 AWG	0190270001
ATP Perishable Tool Kit used in ATP Presses that Process Product on Tape, for 2 Wires with 16 AWG	0190270011

PLEASE CHECK WWW.MOLEX.COM FOR LATEST PART INFORMATION

PART NO.	CARRIER STYLE	TAB SIZE	COLOR	A MAX	B MAX	C MIN	D MIN	E MWID	H NOMINAL
19600-1300	LOOSE PIECE	.250 X .032	YELLOW	.960/24.38	.385/9.78	.245/6.22	.112/2.84	.170/4.31	N/A
19600-1302	LOOSE PIECE	.187 X .020	YELLOW	.880/22.36	.330/8.39	.245/6.22	.112/2.84	.170/4.31	
19600-1304	LOOSE PIECE	.187 X .032	YELLOW	.880/22.36	.330/8.39	.245/6.22	.112/2.84	.170/4.31	
19600-1306	TAPE MOUNT	.250 X .032	YELLOW	.960/24.38	.385/9.78	.245/6.22	.112/2.84	.170/4.31	.56/14.2 (D)
19600-1307	TAPE MOUNT	.187 X .020	YELLOW	.880/22.36	.330/8.39	.245/6.22	.112/2.84	.170/4.31	.64/16.3
19600-1308	TAPE MOUNT	.187 X .032	YELLOW	.880/22.36	.330/8.39	.245/6.22	.112/2.84	.170/4.31	

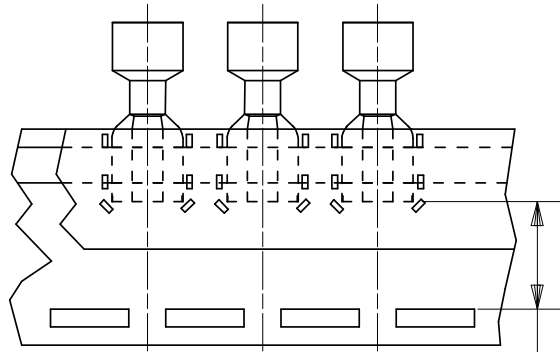
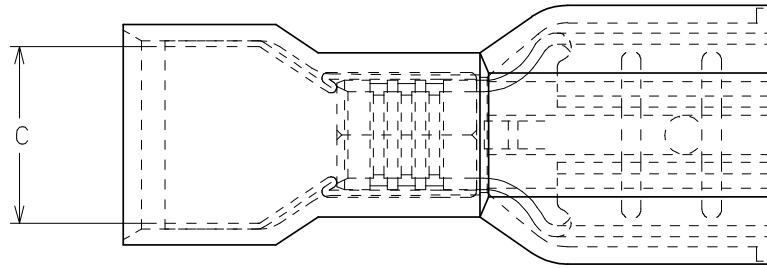
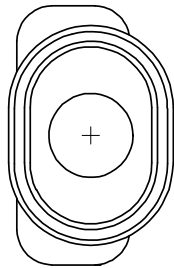

PARTS ON TAPE
(SCALE 2:1) (D)

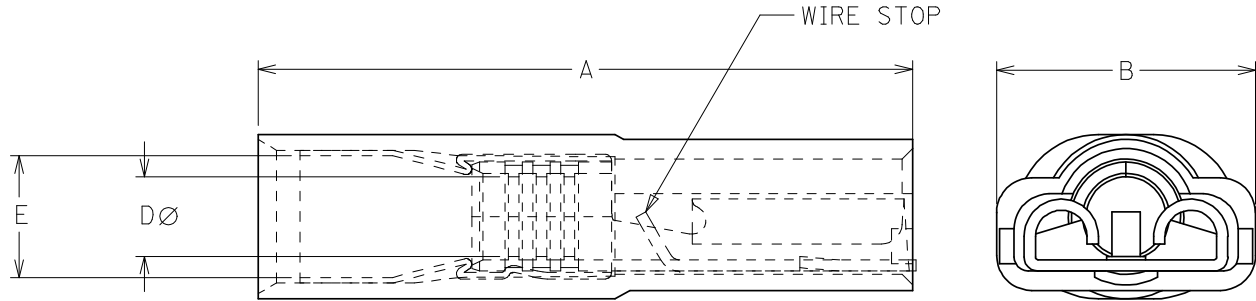

1. TERMINAL MATERIAL: BRASS
2. TERMINAL PLATING: TIN
3. INSULATION MATERIAL: NYLON
4. MWID= MAXIMUM WIRE INSULATION DIAMETER.
5. PARTS TO ACCEPT TWO 22, 20, 18 & 16 OR A COMBINATION OF ANY TWO OF THESE WIRE GAUGES.
6. PART IS RoHS COMPLIANT.

ADD TAPE DIAG. DIMS EC NO: WNA2008-0049 DRAWN:ETHRODAHL 2008/02/14 CHKD:JMACNELL 2008/03/11 APPR:JMACNELL 2008/03/11	QUALITY SYMBOLS ▼=0 ▽=0	GENERAL TOLERANCES (UNLESS SPECIFIED)		DIMENSION STYLE IN/MM		SCALE 10:1	DESIGN UNITS INCH	THIRD ANGLE PROJECTION
		4 PLACES ±--- ±---	mm	INCH	DRAWN BY	DATE	TITLE AVIKRIMP FIQD OVAL EXP. TWO(22,20,18, & 16 AWG) .187 & .250 TAB WIDTH	
		3 PLACES ±--- ±.005			HEB	DATE		
		2 PLACES ±0.13 ±.01			CHECKED BY	DATE	MOLEX INCORPORATED DOCUMENT NO. SD-19600-1300	
1 PLACE ±0.25 ±---			RWD	DATE	SHEET NO. 1 OF 1			
ANGULAR ±---°		DRAFT WHERE APPLICABLE MUST REMAIN WITHIN DIMENSIONS		MATERIAL NO. SEE CHART				
THIS DRAWING CONTAINS INFORMATION THAT IS PROPRIETARY TO MOLEX INCORPORATED AND SHOULD NOT BE USED WITHOUT WRITTEN PERMISSION								