

5 V or 3 V NVRAM supervisor for up to 8 LPSRAMs

Not recommended for new design

Features

- Converts low power SRAM into NVRAMs
- Precision power monitoring and power switching circuitry
- Automatic WRITE-protection when V_{CC} is out-of-tolerance
- Two-input decoder allows control for up to 8 SRAMs (with 2 devices active in parallel)
- Choice of supply voltages and power-fail deselect voltages:
 - M40Z300:
 - $V_{CC} = 4.5\text{ V to }5.5\text{ V}$
 - $THS = V_{SS}: 4.5\text{ V} \leq V_{PFD} \leq 4.75\text{ V}$
 - $THS = V_{OUT}: 4.2\text{ V} \leq V_{PFD} \leq 4.5\text{ V}$
 - M40Z300W:
 - $V_{CC} = 3.0\text{ V to }3.6\text{ V}$
 - $THS = V_{SS}: 2.8\text{ V} \leq V_{PFD} \leq 3.0\text{ V}$
 - $V_{CC} = 2.7\text{ V to }3.3\text{ V}$
 - $THS = V_{OUT}: 2.5\text{ V} \leq V_{PFD} \leq 2.7\text{ V}$
- Reset output (\overline{RST}) for power on reset
- Battery low pin (\overline{BL})
- Less than 12 ns chip enable access propagation delay (for 5.0 V device)
- Packaging includes a 28-lead SOIC and SNAPHAT[®] top (to be ordered separately), or A 16-lead SOIC
- SOIC package provides direct connection for a SNAPHAT top which contains the battery
- RoHS compliant
 - Lead-free second level interconnect

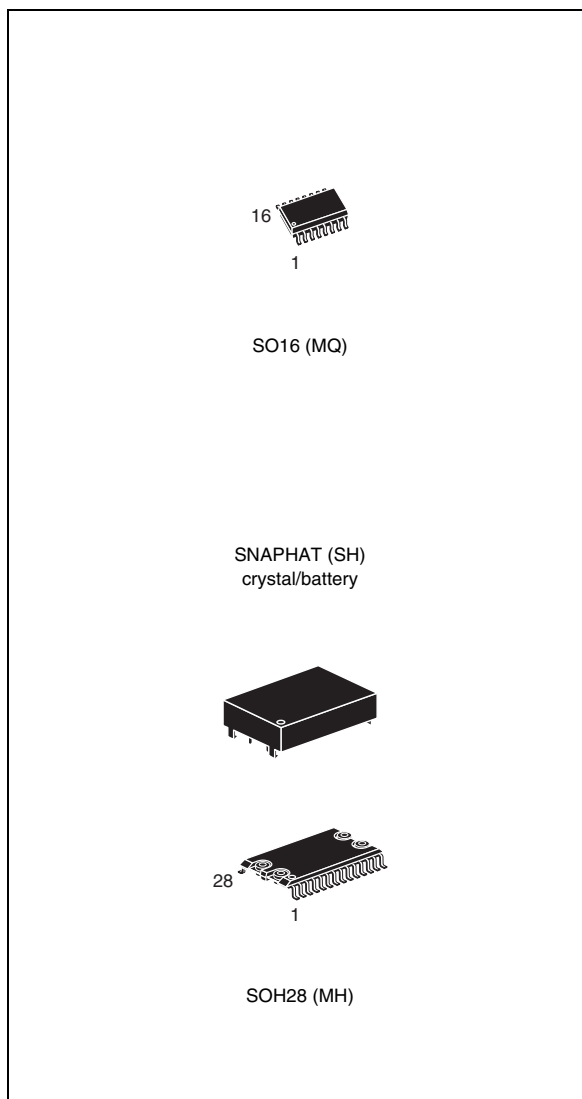

Contents

- 1 Description 5**
- 2 Operation 9**
 - 2.1 Two to four decode 10
 - 2.2 Data retention lifetime calculation 10
 - 2.3 Power-on reset output 11
 - 2.4 Battery low pin 11
 - 2.5 V_{CC} noise and negative going transients 12
- 3 Maximum ratings 13**
- 4 DC and AC parameters 14**
- 5 Package mechanical data 18**
- 6 Part numbering 23**
- 7 Revision history 24**

List of tables

Table 1.	Signal names	6
Table 2.	Truth table.	10
Table 3.	Absolute maximum ratings	13
Table 4.	DC and AC measurement conditions	14
Table 5.	Capacitance	14
Table 6.	DC characteristics.	15
Table 7.	Power down/up mode AC characteristics	17
Table 8.	SOH28 – 28-lead plastic small outline, battery SNAPHAT, package mechanical data . . .	19
Table 9.	SH – 4-pin SNAPHAT housing for 48 mAh battery, package mechanical data	20
Table 10.	SH – 4-pin SNAPHAT housing for 120 mAh battery, package mechanical data	21
Table 11.	SO16 – 16-lead plastic small outline, 150 mils body width, package mechanical data . .	22
Table 12.	Ordering information example	23
Table 13.	SNAPHAT® battery table	23
Table 14.	Document revision history	24

List of figures

Figure 1.	Logic diagram	6
Figure 2.	28-pin SOIC connections	7
Figure 3.	M40Z300 16-pin SOIC connections	7
Figure 4.	M40Z300W 16-pin SOIC connections	7
Figure 5.	Hardware hookup	8
Figure 6.	Address-decode time	10
Figure 7.	Supply voltage protection	12
Figure 8.	AC testing load circuit	14
Figure 9.	Power-down timing	16
Figure 10.	Power-up timing	16
Figure 11.	SOH28 – 28-lead plastic small outline, 4-socket battery SNAPHAT, package outline	19
Figure 12.	SH – 4-pin SNAPHAT housing for 48 mAh battery, package outline	20
Figure 13.	SH – 4-pin SNAPHAT housing for 120mAh battery, package outline.	21
Figure 14.	SO16 – 16-lead plastic small outline, 150 mils body width, package outline	22

1 Description

The M40Z300/W NVRAM supervisor is a self-contained device which converts a standard low-power SRAM into a non-volatile memory. A precision voltage reference and comparator monitors the V_{CC} input for an out-of-tolerance condition.

When an invalid V_{CC} condition occurs, the conditioned chip enable outputs ($\overline{E1}_{CON}$ to $\overline{E4}_{CON}$) are forced inactive to write-protect the stored data in the SRAM. During a power failure, the SRAM is switched from the V_{CC} pin to the lithium cell within the SNAPHAT[®] to provide the energy required for data retention. On a subsequent power-up, the SRAM remains write protected until a valid power condition returns.

The 28-pin, 330 mil SOIC provides sockets with gold plated contacts for direct connection to a separate SNAPHAT housing containing the battery. The SNAPHAT housing has gold plated pins which mate with the sockets, ensuring reliable connection. The housing is keyed to prevent improper insertion. This unique design allows the SNAPHAT battery package to be mounted on top of the SOIC package after the completion of the surface mount process which greatly reduces the board manufacturing process complexity of either directly soldering or inserting a battery into a soldered holder. Providing non-volatility becomes a "SNAP." The 16-pin SOIC provides battery pins for an external user-supplied battery.

Insertion of the SNAPHAT housing after reflow prevents potential battery damage due to the high temperatures required for device surface-mounting. The SNAPHAT housing is also keyed to prevent reverse insertion.

The 28-pin SOIC and battery packages are shipped separately in plastic anti-static tubes or in tape & reel form. For the 28-lead SOIC, the battery/crystal package (e.g., SNAPHAT) part number is "M4ZXX-BR00SH".

Caution: Do not place the SNAPHAT battery top in conductive foam, as this will drain the lithium button-cell battery.

Figure 1. Logic diagram

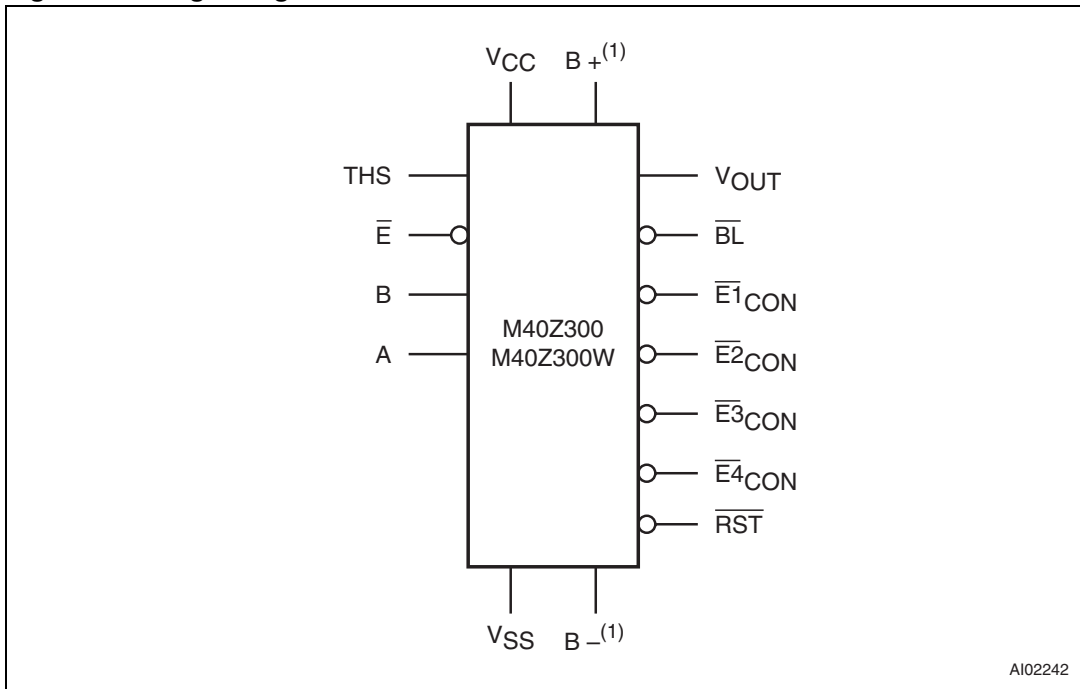

1. For 16-pin SOIC package only.

Table 1. Signal names

THS	Threshold select input
\bar{E}	Chip enable input
$\bar{E1}_{CON} - \bar{E4}_{CON}$	Conditioned chip enable output
A, B	Decoder inputs
\bar{RST}	Reset output (open drain)
\bar{BL}	Battery low output (open drain)
V_{OUT}	Supply voltage output
V_{CC}	Supply voltage
V_{SS}	Ground
B +	Positive battery pin
B -	Negative battery pin ⁽¹⁾
NC	Not connected internally

1. For M40Z300W, B- must be connected to the negative battery terminal only (not to pin 8, V_{SS}).

Figure 2. 28-pin SOIC connections

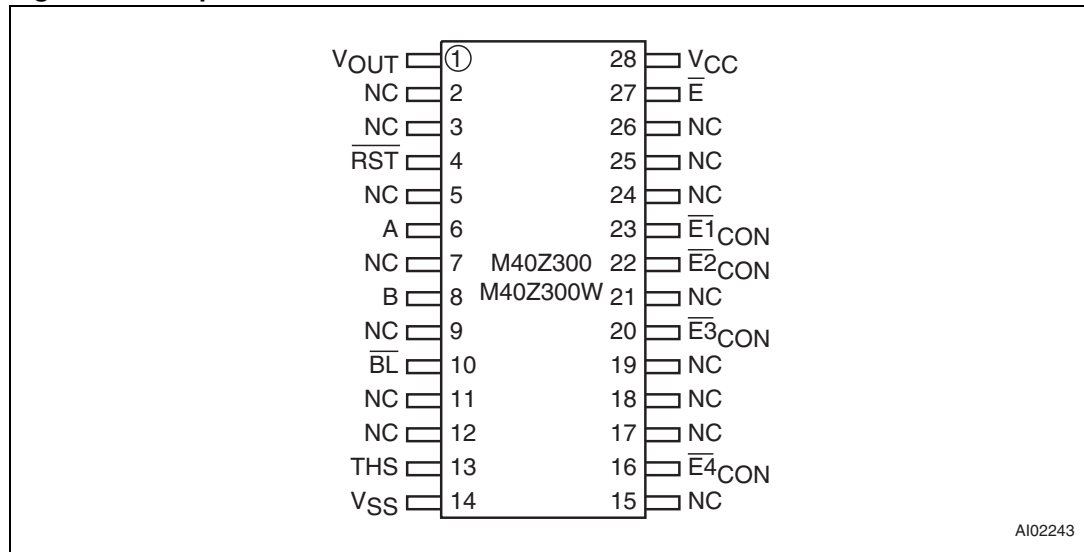

Figure 3. M40Z300 16-pin SOIC connections

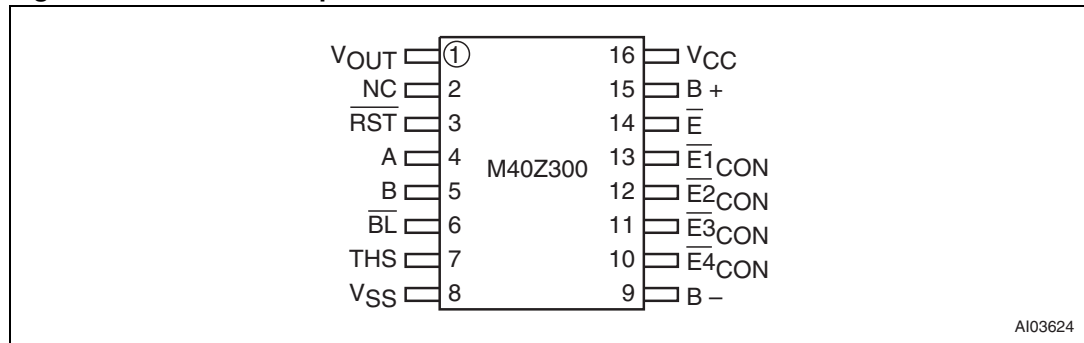
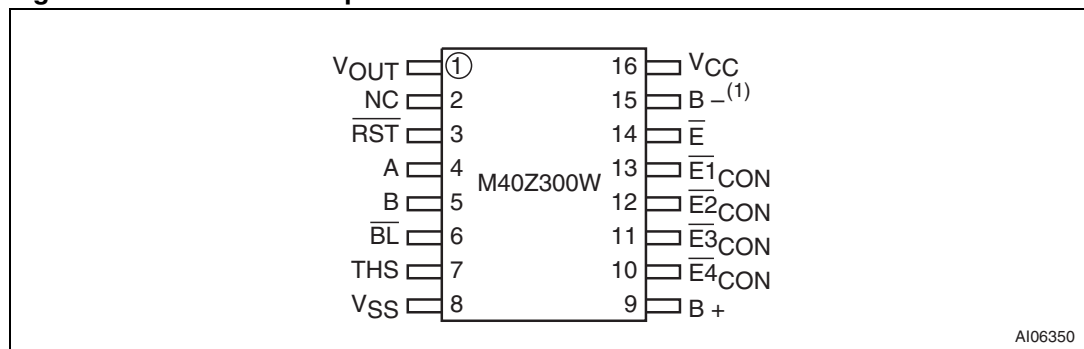
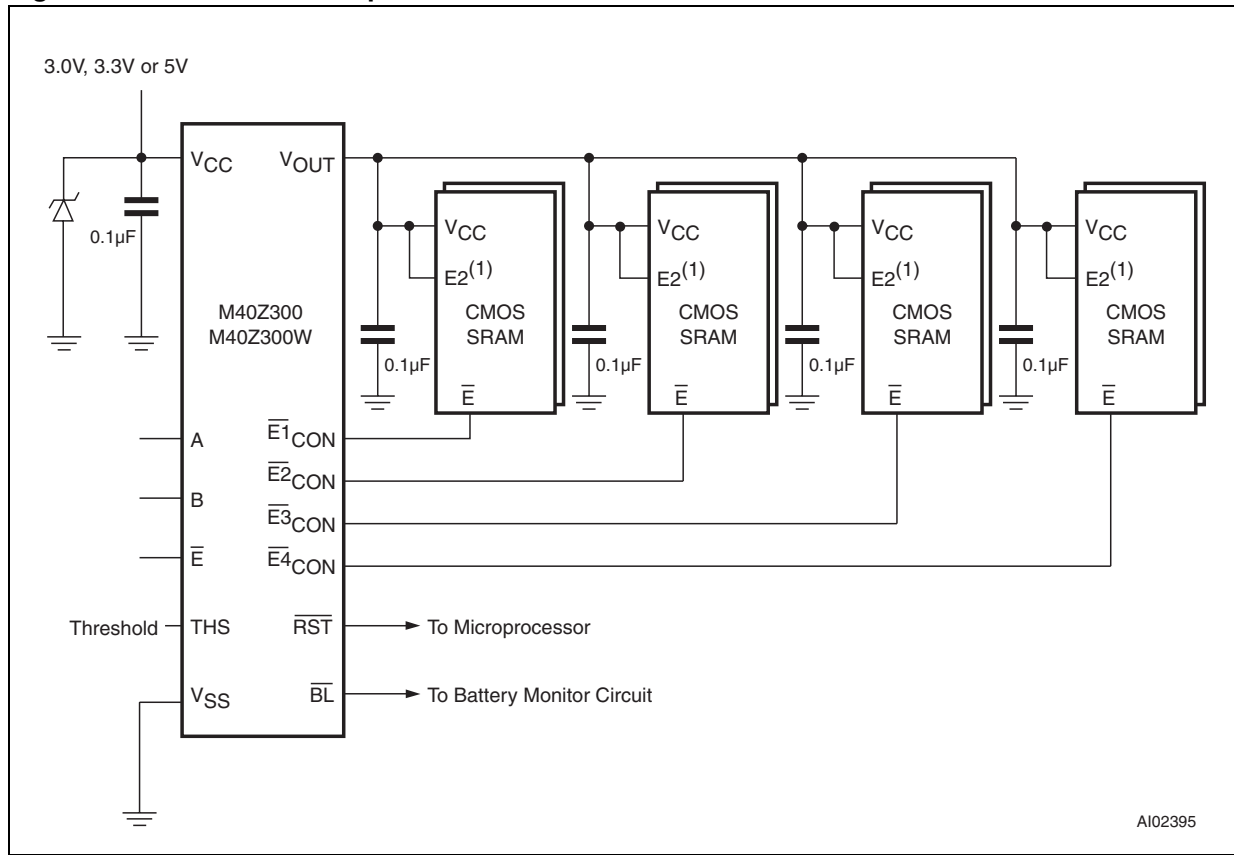

Figure 4. M40Z300W 16-pin SOIC connections



1. For M40Z300W, B- must be connected to the negative battery terminal only (not to pin 8, VSS).

Figure 5. Hardware hookup



- 1. If the second chip enable pin (E2) is unused, it should be tied to V_{OUT}.

2 Operation

The M40Z300/W, as shown in [Figure 5 on page 8](#), can control up to four (eight, if placed in parallel) standard low-power SRAMs. These SRAMs must be configured to have the chip enable input disable all other input signals. Most slow, low-power SRAMs are configured like this, however many fast SRAMs are not. During normal operating conditions, the conditioned chip enable ($\overline{E1}_{CON}$ to $\overline{E4}_{CON}$) output pins follow the chip enable (\overline{E}) input pin with timing shown in [Figure 6 on page 10](#) and [Table 7 on page 17](#). An internal switch connects V_{CC} to V_{OUT} . This switch has a voltage drop of less than 0.3V (I_{OUT1}).

When V_{CC} degrades during a power failure, $\overline{E1}_{CON}$ to $\overline{E4}_{CON}$ are forced inactive independent of \overline{E} . In this situation, the SRAM is unconditionally write protected as V_{CC} falls below an out-of-tolerance threshold (V_{PFD}). For the M40Z300 the power fail detection value associated with V_{PFD} is selected by the Threshold Select (THS) pin and is shown in [Table 6 on page 15](#). For the M40Z300W, the THS pin selects both the supply voltage and V_{PFD} (also shown in [Table 6 on page 15](#)).

Note: In either case, THS pin must be connected to either V_{SS} or V_{OUT} .

If chip enable access is in progress during a power fail detection, that memory cycle continues to completion before the memory is write protected. If the memory cycle is not terminated within time t_{WPT} , $\overline{E1}_{CON}$ to $\overline{E4}_{CON}$ are unconditionally driven high, write protecting the SRAM. A power failure during a WRITE cycle may corrupt data at the currently addressed location, but does not jeopardize the rest of the SRAM's contents. At voltages below V_{PFD} (min), the user can be assured the memory will be write protected within the Write Protect Time (t_{WPT}) provided the V_{CC} fall time exceeds t_F (see [Figure 6 on page 10](#)).

As V_{CC} continues to degrade, the internal switch disconnects V_{CC} and connects the internal battery to V_{OUT} . This occurs at the switchover voltage (V_{SO}). Below the V_{SO} , the battery provides a voltage V_{OHB} to the SRAM and can supply current I_{OUT2} (see [Table 6 on page 15](#)).

When V_{CC} rises above V_{SO} , V_{OUT} is switched back to the supply voltage. Outputs $\overline{E1}_{CON}$ to $\overline{E4}_{CON}$ are held inactive for t_{CER} (120ms maximum) after the power supply has reached V_{PFD} , independent of the \overline{E} input, to allow for processor stabilization (see [Figure 10 on page 16](#)).

2.1 Two to four decode

The M40Z300/W includes a 2 input (A, B) decoder which allows the control of up to 4 independent SRAMs. The truth table for these inputs is shown in [Table 2](#).

Table 2. Truth table

Inputs			Outputs			
\bar{E}	B	A	$\bar{E}1_{CON}$	$E2_{CON}$	$\bar{E}3_{CON}$	$\bar{E}4_{CON}$
H	X	X	H	H	H	H
L	L	L	L	H	H	H
L	L	H	H	L	H	H
L	H	L	H	H	L	H
L	H	H	H	H	H	L

Figure 6. Address-decode time

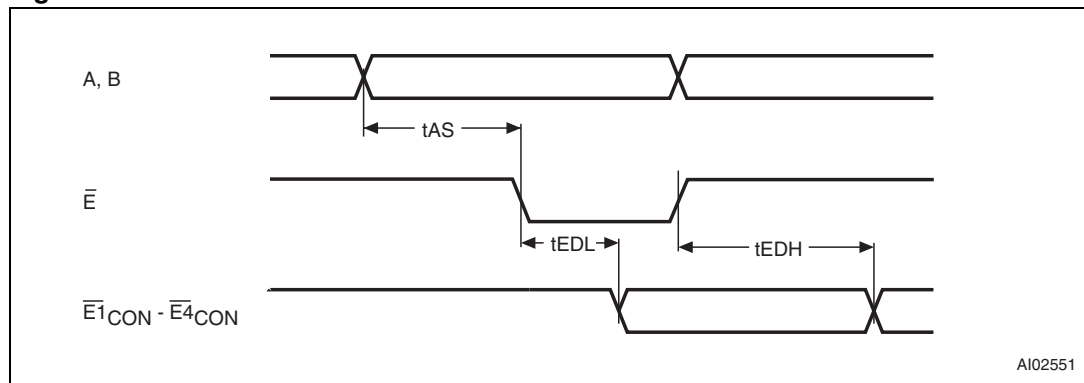

Note: During system design, compliance with the SRAM timing parameters must comprehend the propagation delay between $\bar{E}1_{CON}$ - $\bar{E}4_{CON}$.

2.2 Data retention lifetime calculation

Most low power SRAMs on the market today can be used with the M40Z300/W NVRAM SUPERVISOR. There are, however some criteria which should be used in making the final choice of which SRAM to use. The SRAM must be designed in a way where the chip enable input disables all other inputs to the SRAM. This allows inputs to the M40Z300/W and SRAMs to be “Don't Care” once V_{CC} falls below $V_{PFD}(\min)$. The SRAM should also guarantee data retention down to $V_{CC} = 2.0$ V. The chip enable access time must be sufficient to meet the system needs with the chip enable propagation delays included. If the SRAM includes a second chip enable pin ($\bar{E}2$), this pin should be tied to V_{OUT} .

If data retention lifetime is a critical parameter for the system, it is important to review the data retention current specifications for the particular SRAMs being evaluated. Most SRAMs specify a data retention current at 3.0 V. Manufacturers generally specify a typical condition for room temperature along with a worst case condition (generally at elevated temperatures). The system level requirements will determine the choice of which value to use.

The data retention current value of the SRAMs can then be added to the I_{BAT} value of the M40Z300/W to determine the total current requirements for data retention. The available battery capacity for the SNAPHAT® of your choice can then be divided by this current to determine the amount of data retention available (see [Table 13 on page 23](#)).

Caution: Take care to avoid inadvertent discharge through V_{OUT} and $\overline{E1}_{CON}$ - $\overline{E4}_{CON}$ after battery has been attached.

For a further more detailed review of lifetime calculations, please see application note AN1012.

2.3 Power-on reset output

All microprocessors have a reset input which forces them to a known state when starting. The M40Z300/W has a reset output (\overline{RST}) pin which is guaranteed to be low within t_{WPT} of V_{PFD} (see [Table 7](#)). This signal is an open drain configuration. An appropriate pull-up resistor should be chosen to control the rise time. This signal will be valid for all voltage conditions, even when V_{CC} equals V_{SS} .

Once V_{CC} exceeds the power failure detect voltage V_{PFD} , an internal timer keeps \overline{RST} low for t_{REC} to allow the power supply to stabilize.

2.4 Battery low pin

The M40Z300/W automatically performs battery voltage monitoring upon power-up, and at factory-programmed time intervals of at least 24 hours. The battery low (\overline{BL}) pin will be asserted if the battery voltage is found to be less than approximately 2.5 V. The \overline{BL} pin will remain asserted until completion of battery replacement and subsequent battery low monitoring tests, either during the next power-up sequence or the next scheduled 24-hour interval.

If a battery low is generated during a power-up sequence, this indicates that the battery is below 2.5 V and may not be able to maintain data integrity in the SRAM. Data should be considered suspect, and verified as correct. A fresh battery should be installed.

If a battery low indication is generated during the 24-hour interval check, this indicates that the battery is near end of life. However, data is not compromised due to the fact that a nominal V_{CC} is supplied. In order to insure data integrity during subsequent periods of battery backup mode, the battery should be replaced. The SNAPHAT® top should be replaced with valid V_{CC} applied to the device.

The M40Z300/W only monitors the battery when a nominal V_{CC} is applied to the device. Thus applications which require extensive durations in the battery backup mode should be powered-up periodically (at least once every few months) in order for this technique to be beneficial. Additionally, if a battery low is indicated, data integrity should be verified upon power-up via a checksum or other technique. The \overline{BL} pin is an open drain output and an appropriate pull-up resistor to V_{CC} should be chosen to control the rise time.

2.5 V_{CC} noise and negative going transients

I_{CC} transients, including those produced by output switching, can produce voltage fluctuations, resulting in spikes on the V_{CC} bus. These transients can be reduced if capacitors are used to store energy which stabilizes the V_{CC} bus. The energy stored in the bypass capacitors will be released as low going spikes are generated or energy will be absorbed when overshoots occur. A ceramic bypass capacitor value of $0.1 \mu\text{F}$ (as shown in [Figure 7](#)) is recommended in order to provide the needed filtering.

In addition to transients that are caused by normal SRAM operation, power cycling can generate negative voltage spikes on V_{CC} that drive it to values below V_{SS} by as much as one volt. These negative spikes can cause data corruption in the SRAM while in battery backup mode. To protect from these voltage spikes, STMicroelectronics recommends connecting a Schottky diode from V_{CC} to V_{SS} (cathode connected to V_{CC} , anode to V_{SS}). Schottky diode 1N5817 is recommended for through hole and MBR5120T3 is recommended for surface mount.

Figure 7. Supply voltage protection

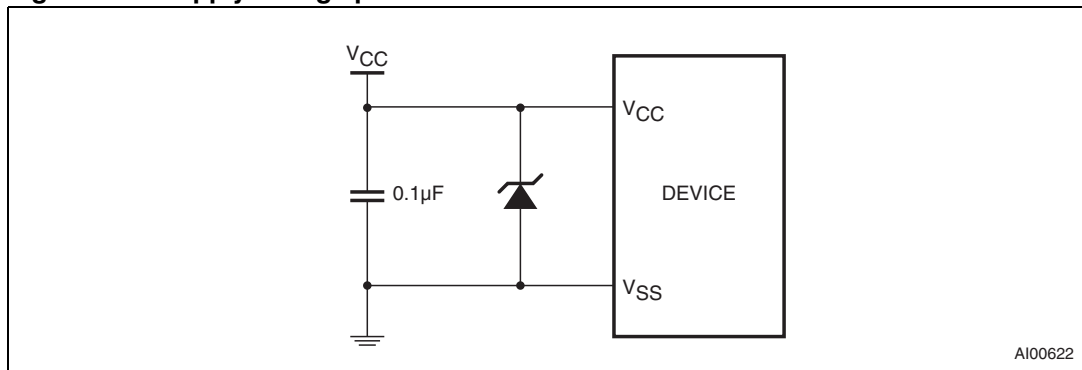

3 Maximum ratings

Stressing the device above the rating listed in the absolute maximum ratings table may cause permanent damage to the device. These are stress ratings only and operation of the device at these or any other conditions above those indicated in the operating sections of this specification is not implied. Exposure to absolute maximum rating conditions for extended periods may affect device reliability.

Table 3. Absolute maximum ratings

Symbol	Parameter	Value	Unit	
T _A	Ambient operating temperature	Grade 1	0 to 70	°C
		Grade 6	−40 to 85	°C
T _{STG}	Storage temperature	SNAPHAT®	−40 to 85	°C
		SOIC	−55 to 125	°C
T _{SLD} ⁽¹⁾	Lead solder temperature for 10 seconds	260	°C	
V _{IO}	Input or output voltage	−0.3 to V _{CC} + 0.3	V	
V _{CC}	Supply voltage	M40Z300	−0.3 to 7.0	V
		M40Z300W	−0.3 to 4.6	V
I _O	Output current	20	mA	
P _D	Power dissipation	1	W	

1. For SO package, Lead-free (Pb-free) lead finish: Reflow at peak temperature of 260°C (total thermal budget not to exceed 245°C for greater than 30 seconds).

Caution: Negative undershoots below −0.3 V are not allowed on any pin while in the battery backup mode.

Caution: Do NOT wave solder SOIC to avoid damaging SNAPHAT sockets.

4 DC and AC parameters

This section summarizes the operating and measurement conditions, as well as the DC and AC characteristics of the device. The parameters in the following DC and AC characteristic tables are derived from tests performed under the measurement conditions listed in [Table 4: DC and AC measurement conditions](#). Designers should check that the operating conditions in their projects match the measurement conditions when using the quoted parameters.

Table 4. DC and AC measurement conditions

Parameter		M40Z300	M40Z300W
V _{CC} supply voltage		4.5 to 5.5 V	2.7 to 3.6 V
Ambient operating temperature	Grade 1	0 to 70 °C	0 to 70 °C
	Grade 6	-40 to 85 °C	-40 to 85 °C
Load capacitance (C _L)		100 pF	50 pF
Input rise and fall times		≤ 5 ns	≤ 5 ns
Input pulse voltages		0 to 3 V	0 to 3 V
Input and output timing ref. voltages		1.5 V	1.5 V

Note: Output High Z is defined as the point where data is no longer driven.

Figure 8. AC testing load circuit

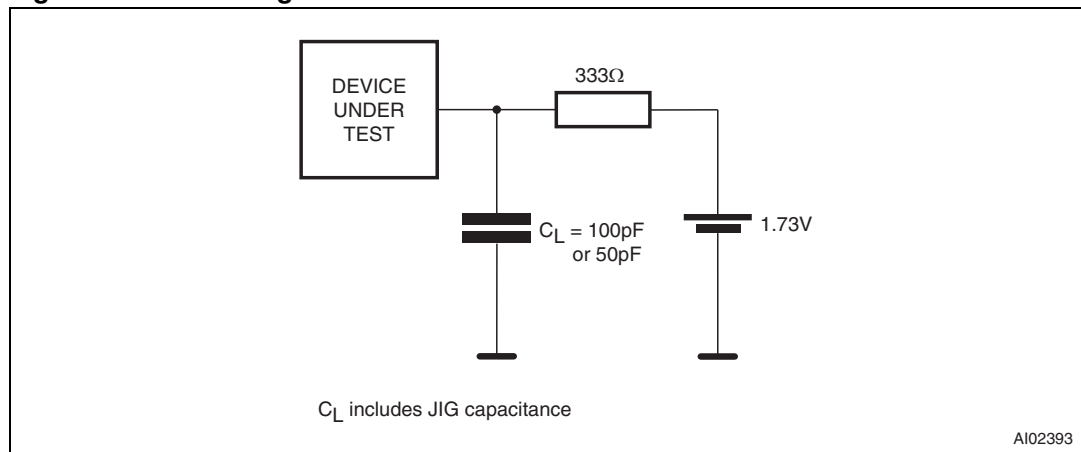

Note: 50 pF for M40Z300W.

Table 5. Capacitance

Symbol	Parameter ⁽¹⁾⁽²⁾	Min	Max	Unit
C _{IN}	Input capacitance	-	8	pF
C _{OUT} ⁽³⁾	Input/output capacitance	-	10	pF

1. Sampled only, not 100% tested.
2. At 25 °C, f = 1 MHz.
3. Outputs deselected.

Table 6. DC characteristics

Sym	Parameter	Test condition ⁽¹⁾	M40Z300			M40Z300W			Unit
			Min	Typ	Max	Min	Typ	Max	
$I_{LI}^{(2)}$	Input leakage current	$0\text{ V} \leq V_{IN} \leq V_{CC}$			± 1			± 1	μA
I_{CC}	Supply current	Outputs open		3	6		2	4	mA
V_{IL}	Input low voltage		-0.3		0.8	-0.3		0.8	V
V_{IH}	Input high voltage		2.2		$V_{CC} + 0.3$	2.0		$V_{CC} + 0.3$	V
V_{OL}	Output low voltage	$I_{OL} = 4.0\text{ mA}$			0.4			0.4	V
	Output low voltage (open drain) ⁽³⁾	$I_{OL} = 10\text{ mA}$			0.4			0.4	V
V_{OH}	Output high voltage	$I_{OH} = -2.0\text{ mA}$	2.4			2.4			V
V_{OHB}	V_{OH} battery backup ⁽⁴⁾	$I_{OUT2} = -1.0\ \mu\text{A}$	2.0	2.9	3.6	2.0	2.9	3.6	V
I_{OUT1}	V_{OUT} current (active)	$V_{OUT} > V_{CC} - 0.3$			250			150	mA
		$V_{OUT} > V_{CC} - 0.2$			150			100	mA
I_{OUT2}	V_{OUT} current (battery backup)	$V_{OUT} > V_{BAT} - 0.3$		100			100		μA
I_{CCDR}	Data retention mode current ⁽⁵⁾				100			100	nA
THS	Threshold select voltage		V_{SS}		V_{OUT}	V_{SS}		V_{OUT}	V
V_{PFD}	Power-fail deselect voltage (THS = V_{SS})		4.5	4.6	4.75	2.8	2.9	3.0	V
	Power-fail deselect voltage (THS = V_{OUT})		4.2	4.35	4.5	2.5	2.6	2.7	V
V_{SO}	Battery backup switchover voltage			3.0			2.5		V
V_{BAT}	Battery voltage		2.0	2.9	3.6	2.0	2.9	3.6	V

- Valid for ambient operating temperature: $T_A = 0$ to $70\text{ }^\circ\text{C}$ or -40 to $85\text{ }^\circ\text{C}$; $V_{CC} = 2.7$ to 3.6 V or 4.5 to 5.5 V (except where noted).
- Outputs deselected.
- For $\overline{\text{RST}}$ & $\overline{\text{BL}}$ pins (open drain).
- Chip enable outputs ($\overline{\text{E1}}_{\text{CON}}$ - $\overline{\text{E4}}_{\text{CON}}$) can only sustain CMOS leakage currents in the battery backup mode. Higher leakage currents will reduce battery life.
- Measured with V_{OUT} and $\overline{\text{E1}}_{\text{CON}}$ - $\overline{\text{E4}}_{\text{CON}}$ open.

Figure 9. Power-down timing

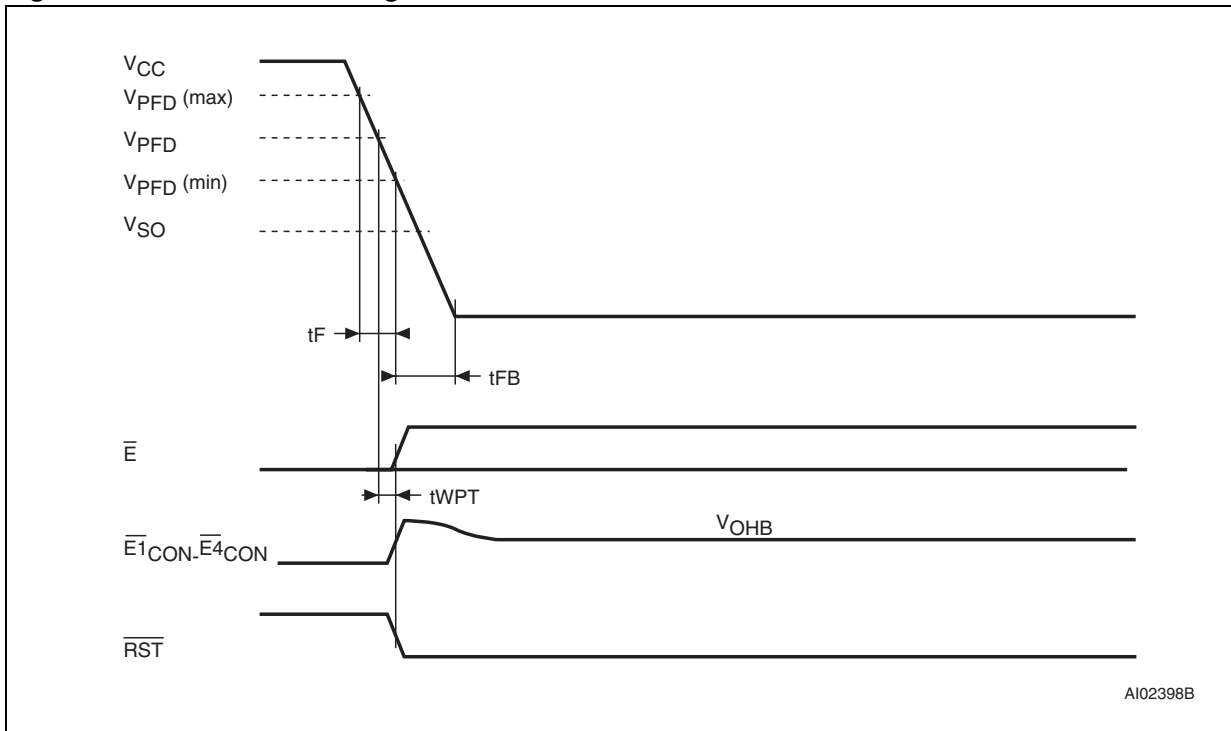

Figure 10. Power-up timing

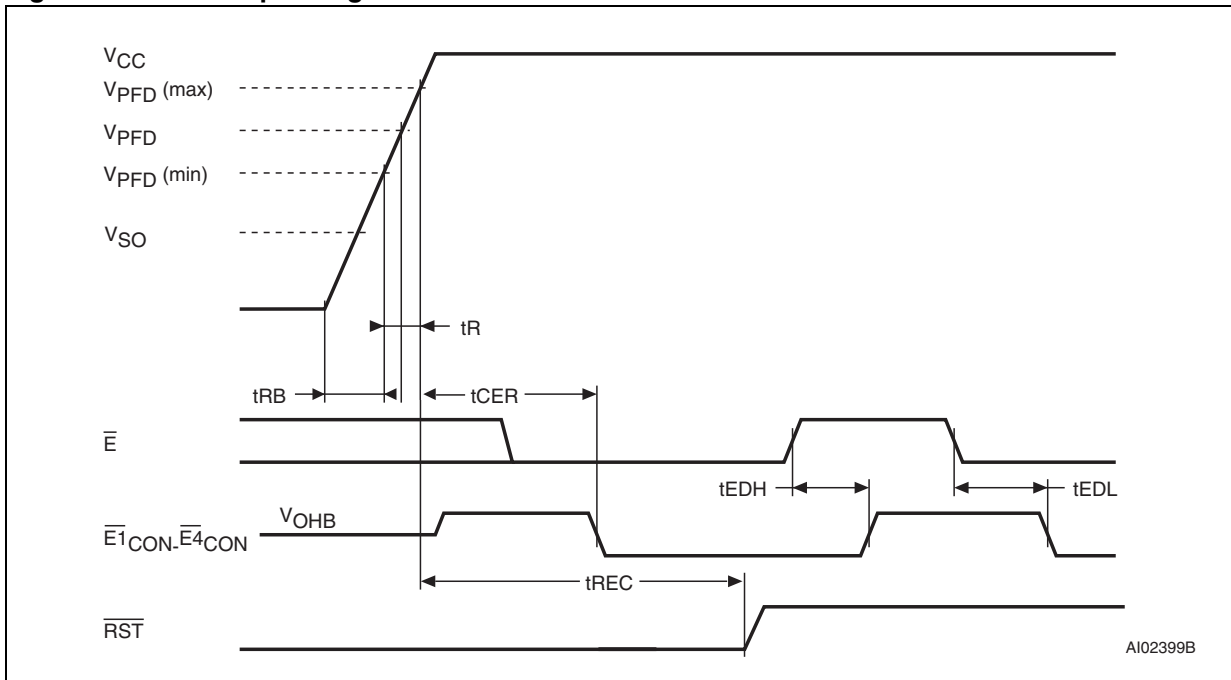

Table 7. Power down/up mode AC characteristics

Symbol	Parameter ⁽¹⁾	Min	Max	Unit	
$t_F^{(2)}$	$V_{PFD}(\text{max})$ to $V_{PFD}(\text{min})$ V_{CC} fall time	300		μs	
$t_{FB}^{(3)}$	$V_{PFD}(\text{min})$ to V_{SS} V_{CC} fall time	M40Z300	10	μs	
		M40Z300W	150	μs	
t_R	$V_{PFD}(\text{min})$ to $V_{PFD}(\text{max})$ V_{CC} rise time	10		μs	
t_{EDL}	Chip enable propagation delay low	M40Z300	12	ns	
		M40Z300W	20	ns	
t_{EDH}	Chip enable propagation delay high	M40Z300	10	ns	
		M40Z300W	20	ns	
t_{AS}	A, B set up to \bar{E}	0		ns	
t_{CER}	Chip enable recovery	40	120	ms	
$t_{REC}^{(4)}$	$V_{PFD}(\text{max})$ to \overline{RST} high	40	120	ms	
t_{WPT}	Write protect time	M40Z300	40	150	μs
		M40Z300W	40	250	μs
t_{RB}	V_{SS} to $V_{PFD}(\text{min})$ V_{CC} rise time	1		μs	

- Valid for ambient operating temperature: $T_A = 0$ to 70 °C or -40 to 85 °C; $V_{CC} = 2.7$ to 3.6 V or 4.5 to 5.5 V (except where noted).
- $V_{PFD}(\text{max})$ to $V_{PFD}(\text{min})$ fall time of less than t_F may result in deselection/write protection not occurring until 200 μs after V_{CC} passes $V_{PFD}(\text{min})$.
- $V_{PFD}(\text{min})$ to V_{SS} fall time of less than t_{FB} may cause corruption of RAM data.
- $t_{REC}(\text{min}) = 20\text{ms}$ for industrial temperature Grade 6 device.

5 Package mechanical data

In order to meet environmental requirements, ST offers these devices in different grades of ECOPACK[®] packages, depending on their level of environmental compliance. ECOPACK[®] specifications, grade definitions and product status are available at: www.st.com. ECOPACK[®] is an ST trademark.

Figure 11. SOH28 – 28-lead plastic small outline, 4-socket battery SNAPHAT, package outline

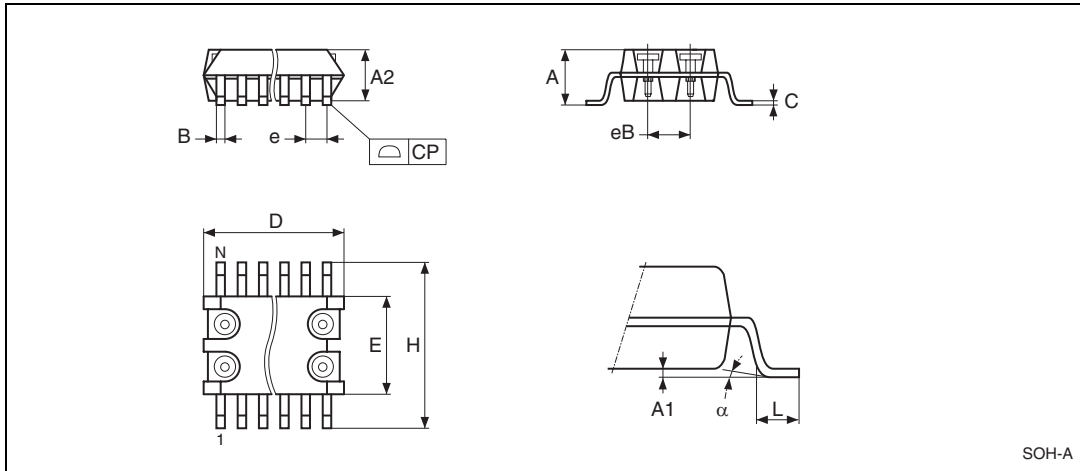

Note: Drawing is not to scale.

Table 8. SOH28 – 28-lead plastic small outline, battery SNAPHAT, package mechanical data

Symbol	mm			inches		
	Typ	Min	Max	Typ	Min	Max
A			3.05			0.120
A1		0.05	0.36		0.002	0.014
A2		2.34	2.69		0.092	0.106
B		0.36	0.51		0.014	0.020
C		0.15	0.32		0.006	0.012
D		17.71	18.49		0.697	0.728
E		8.23	8.89		0.324	0.350
e	1.27	–	–	0.050	–	–
eB		3.20	3.61		0.126	0.142
H		11.51	12.70		0.453	0.500
L		0.41	1.27		0.016	0.050
α		0°	8°		0°	8°
N	28			28		
CP			0.10			0.004

Figure 12. SH – 4-pin SNAPHAT housing for 48 mAh battery, package outline

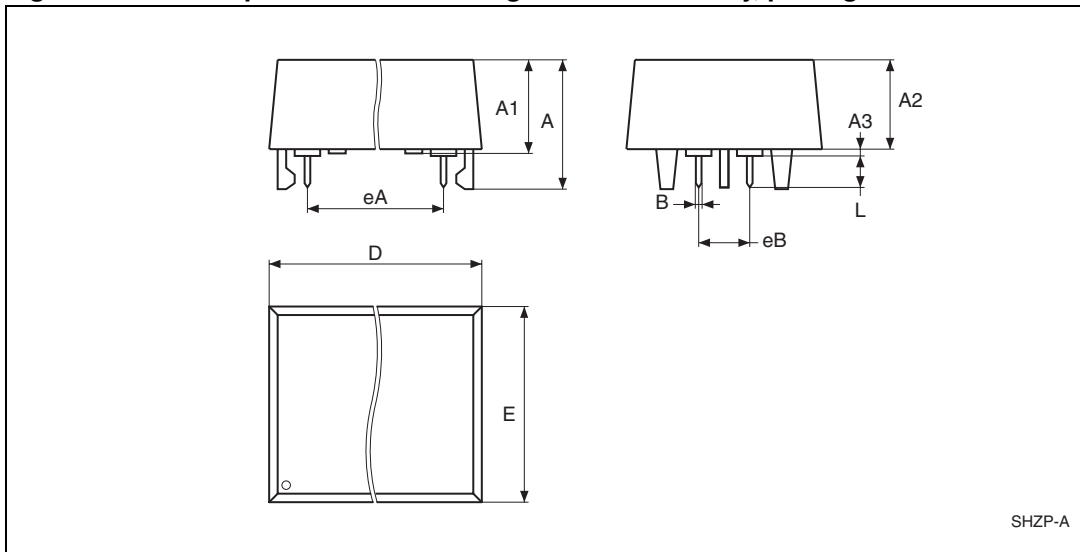

Note: Drawing is not to scale.

Table 9. SH – 4-pin SNAPHAT housing for 48 mAh battery, package mechanical data

Symbol	mm			inches		
	Typ	Min	Max	Typ	Min	Max
A			9.78			0.385
A1		6.73	7.24		0.265	0.285
A2		6.48	6.99		0.255	0.275
A3			0.38			0.015
B		0.46	0.56		0.018	0.022
D		21.21	21.84		0.835	0.860
E		14.22	14.99		0.560	0.590
eA		15.55	15.95		0.612	0.628
eB		3.20	3.61		0.126	0.142
L		2.03	2.29		0.080	0.090

Figure 13. SH – 4-pin SNAPHAT housing for 120mAh battery, package outline

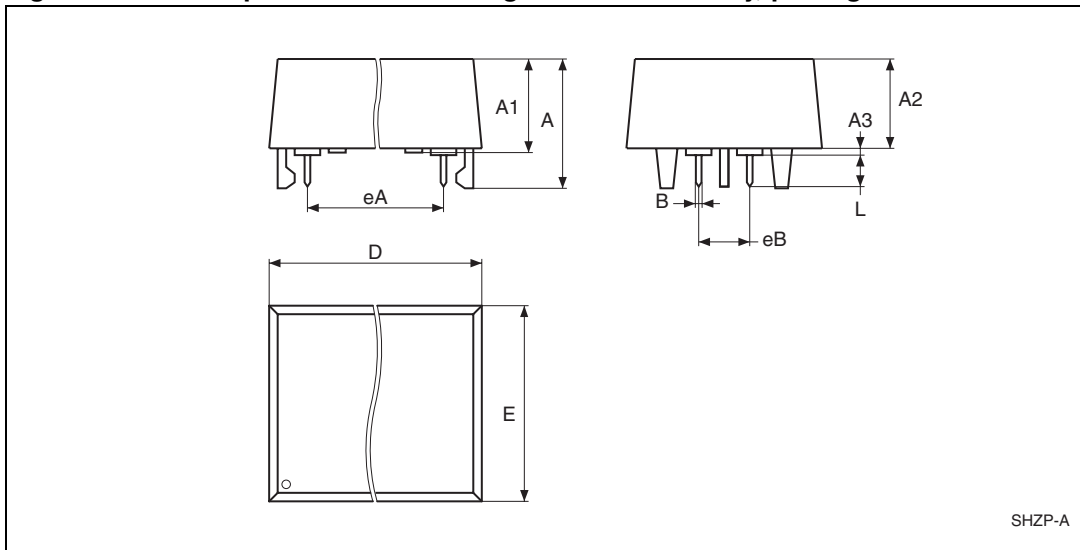

Note: Drawing is not to scale.

Table 10. SH – 4-pin SNAPHAT housing for 120 mAh battery, package mechanical data

Symbol	mm			inches		
	Typ	Min	Max	Typ	Min	Max
A			10.54			0.415
A1		8.00	8.51		0.315	.0335
A2		7.24	8.00		0.285	0.315
A3			0.38			0.015
B		0.46	0.56		0.018	0.022
D		21.21	21.84		0.835	0.860
E		17.27	18.03		0.680	0.710
eA		15.55	15.95		0.612	0.628
eB		3.20	3.61		0.126	0.142
L		2.03	2.29		0.080	0.090

Figure 14. SO16 – 16-lead plastic small outline, 150 mils body width, package outline

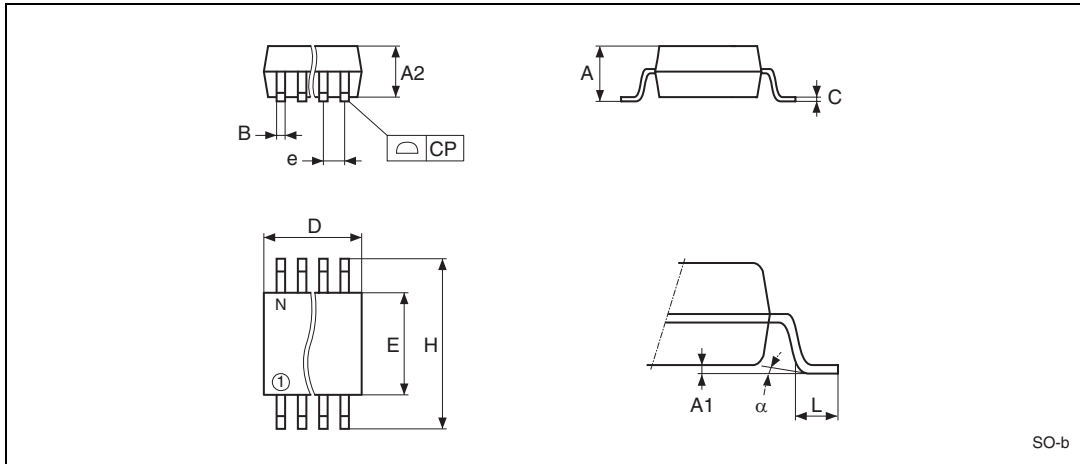

Note: Drawing is not to scale.

Table 11. SO16 – 16-lead plastic small outline, 150 mils body width, package mechanical data

Symbol	mm			inches		
	Typ.	Min.	Max.	Typ.	Min.	Max.
A			1.75			0.069
A1		0.10	0.25		0.004	0.010
A2			1.60			0.063
B		0.35	0.46		0.014	0.018
C		0.19	0.25		0.007	0.010
D		9.80	10.00		0.386	0.394
E		3.80	4.00		0.150	0.158
e	1.27	–	–	0.050	–	–
H		5.80	6.20		0.228	0.244
L		0.40	1.27		0.016	0.050
a		0°	8°		0°	8°
N	16			16		
CP			0.10			0.004

6 Part numbering

Table 12. Ordering information example

Example:	M40Z	300W	MH	1	E
Device type					
M40Z					
Supply and write protect voltage					
300 ⁽¹⁾ = V _{CC} = 4.5 to 5.5 V					
THS = V _{SS} = 4.5 V ≤ V _{PFD} ≤ 4.75 V					
THS = V _{OUT} = 4.2 V ≤ V _{PFD} ≤ 4.5 V					
300W ⁽¹⁾ = V _{CC} = 3.0 to 3.6 V					
THS = V _{SS} = 2.8 V ≤ V _{PFD} ≤ 3.0 V					
V _{CC} = 2.7 V to 3.3 V					
THS = V _{OUT} = 2.5 V ≤ V _{PFD} ≤ 2.7 V					
Package					
MH ⁽²⁾ = SOH28					
MQ = SO16					
Temperature range					
1 = 0 to 70 °C					
6 = -40 to 85 °C					
Shipping method for SOIC					

E = Lead-free package (ECOPACK[®]), tubes

F = Lead-free package (ECOPACK[®]), tape & reel

1. Not recommended for new design. Contact ST sales office for availability.
2. The SOIC package (SOH28) requires the battery package (SNAPHAT[®]) which is ordered separately under the part number "M4Zxx-BR00SH" in plastic tubes or "M4Zxx-BR00SHTR" in tape & reel form.

Caution: Do not place the SNAPHAT battery package "M4Zxx-BR00SH" in conductive foam as it will drain the lithium button-cell battery.

For other options, or for more information on any aspect of this device, please contact the ST sales office nearest you

Table 13. SNAPHAT[®] battery table

Part number	Description	Package
M4Z28-BR00SH1	Lithium battery (48 mAh) SNAPHAT	SH
M4Z32-BR00SH1	Lithium battery (120 mAh) SNAPHAT	SH

7 Revision history

Table 14. Document revision history

Date	Revision	Changes
Mar-1999	1.0	First issue
08-Mar-2000	1.1	Document layout changed; SO16 package added; battery capacity changed (Table 13)
22-Sep-2000	1.2	SO16 package measures change
23-Feb-2001	1.3	Added information for industrial temperature (Table 3 , 7 , 12)
30-May-2001	1.4	Change “Controller” references to “SUPERVISOR”
10-Jul-2001	2.0	Reformatted; added temp/voltage info. to tables (Table 6 , 7); Figures changed (Figure 1 , 3 , 5 , 8 , 6)
01-Aug-2001	2.1	E2 connections added to hookup (Figure 5)
15-Jan-2002	2.2	16-pin SOIC connections split, graphic added (Figure 4); addition to hardware hookup (Figure 5)
13-May-2002	2.3	Modify reflow time and temperature footnote (Table 3)
31-Oct-2003	2.4	Update DC characteristics (Table 6)
04-Nov-2003	2.5	Correct DC characteristics (Table 6)
23-Feb-2005	3.0	Reformatted; IR reflow, SO package updates (Table 3)
05-Nov-2007	4.0	Reformatted; added lead-free second level interconnect to cover page and Section 5: Package mechanical data ; updated Figure 10 and Table 3 , 12 , 13 .
19-Oct-2010	5	Devices not recommended for new design, updated document status; updated Table 12 , ECOPACK [®] text in Section 5: Package mechanical data ; reformatted document.

Please Read Carefully:

Information in this document is provided solely in connection with ST products. STMicroelectronics NV and its subsidiaries ("ST") reserve the right to make changes, corrections, modifications or improvements, to this document, and the products and services described herein at any time, without notice.

All ST products are sold pursuant to ST's terms and conditions of sale.

Purchasers are solely responsible for the choice, selection and use of the ST products and services described herein, and ST assumes no liability whatsoever relating to the choice, selection or use of the ST products and services described herein.

No license, express or implied, by estoppel or otherwise, to any intellectual property rights is granted under this document. If any part of this document refers to any third party products or services it shall not be deemed a license grant by ST for the use of such third party products or services, or any intellectual property contained therein or considered as a warranty covering the use in any manner whatsoever of such third party products or services or any intellectual property contained therein.

UNLESS OTHERWISE SET FORTH IN ST'S TERMS AND CONDITIONS OF SALE ST DISCLAIMS ANY EXPRESS OR IMPLIED WARRANTY WITH RESPECT TO THE USE AND/OR SALE OF ST PRODUCTS INCLUDING WITHOUT LIMITATION IMPLIED WARRANTIES OF MERCHANTABILITY, FITNESS FOR A PARTICULAR PURPOSE (AND THEIR EQUIVALENTS UNDER THE LAWS OF ANY JURISDICTION), OR INFRINGEMENT OF ANY PATENT, COPYRIGHT OR OTHER INTELLECTUAL PROPERTY RIGHT.

UNLESS EXPRESSLY APPROVED IN WRITING BY AN AUTHORIZED ST REPRESENTATIVE, ST PRODUCTS ARE NOT RECOMMENDED, AUTHORIZED OR WARRANTED FOR USE IN MILITARY, AIR CRAFT, SPACE, LIFE SAVING, OR LIFE SUSTAINING APPLICATIONS, NOR IN PRODUCTS OR SYSTEMS WHERE FAILURE OR MALFUNCTION MAY RESULT IN PERSONAL INJURY, DEATH, OR SEVERE PROPERTY OR ENVIRONMENTAL DAMAGE. ST PRODUCTS WHICH ARE NOT SPECIFIED AS "AUTOMOTIVE GRADE" MAY ONLY BE USED IN AUTOMOTIVE APPLICATIONS AT USER'S OWN RISK.

Resale of ST products with provisions different from the statements and/or technical features set forth in this document shall immediately void any warranty granted by ST for the ST product or service described herein and shall not create or extend in any manner whatsoever, any liability of ST.

ST and the ST logo are trademarks or registered trademarks of ST in various countries.

Information in this document supersedes and replaces all information previously supplied.

The ST logo is a registered trademark of STMicroelectronics. All other names are the property of their respective owners.

© 2010 STMicroelectronics - All rights reserved

STMicroelectronics group of companies

Australia - Belgium - Brazil - Canada - China - Czech Republic - Finland - France - Germany - Hong Kong - India - Israel - Italy - Japan - Malaysia - Malta - Morocco - Philippines - Singapore - Spain - Sweden - Switzerland - United Kingdom - United States of America

www.st.com

