

PLEASE CHECK WWW.MOLEX.COM FOR LATEST PART INFORMATION

Part Number: [0714362364](#)
Status: **Active**
Description: 1.00mm (.039") Pitch Mezzanine IEEE 1386 Plug, Surface Mount, Dual Row, Vertical Stacking, 64 Circuits, 8.35mm (.329") Unmated Height, with PCB Locator Pegs, with Robotic Placement Metal Cap, 0.76µm (30µ") Gold (Au) Selective Plating, Tube Pac

Documents:

[3D Model](#) [Product Specification PS-71436-9999 \(PDF\)](#)
[Drawing \(PDF\)](#) [RoHS Certificate of Compliance \(PDF\)](#)

Agency Certification

CSA LR19980
 UL E29179

General

Product Family PCB Headers
 Series [71436](#)
 Application Board-to-Board
 Product Name Mezzanine

Physical

Breakaway No
 Circuits (Loaded) 64
 Circuits (maximum) 64
 Color - Resin Natural
 Flammability 94V-0
 Glow-Wire Compliant No
 Lock to Mating Part None
 Mated Height (in) 0.394 In, 0.472 In, 0.512 In, 0.591 In
 Mated Height (mm) 10.00 mm, 12.00 mm, 13.00 mm, 15.00 mm
 Material - Metal Phosphor Bronze
 Material - Plating Mating Gold
 Material - Plating Termination Tin
 Material - Resin High Temperature Thermoplastic
 Number of Rows 2
 Orientation Vertical
 PCB Locator Yes
 PCB Retention None
 PCB Thickness Recommended (in) 0.040 In
 PCB Thickness Recommended (mm) 1.00 mm
 Packaging Type Tube
 Pitch - Mating Interface (in) 0.039 In
 Pitch - Mating Interface (mm) 1.00 mm
 Plating min: Mating (µin) 30.4
 Plating min: Mating (µm) 0.76
 Plating min: Termination (µin) 76.4
 Plating min: Termination (µm) 1.91
 Polarized to Mating Part No
 Shrouded Fully
 Stackable No
 Temperature Range - Operating -55°C to +85°C
 Termination Interface: Style Surface Mount

Electrical

Current - Maximum per Contact 1A
 Voltage - Maximum 100V

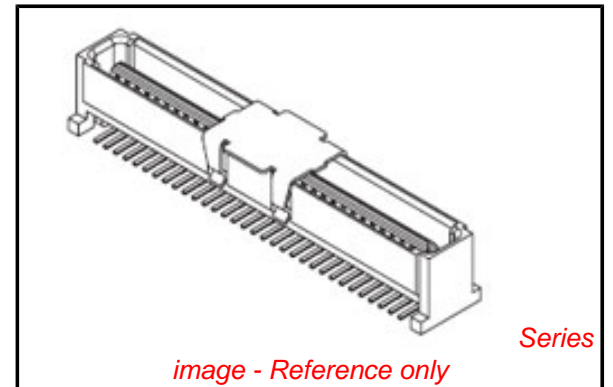

image - Reference only

EU RoHS

ELV and RoHS Compliant
REACH SVHC
 Not Reviewed
Halogen-Free Status

China RoHS



Not Reviewed

Need more information on product environmental compliance?

Email productcompliance@molex.com
 For a multiple part number RoHS Certificate of Compliance, [click here](#)

Please visit the [Contact Us](#) section for any non-product compliance questions.

Search Parts in this Series

[71436Series](#)

Mates With

[714390](#) for Stack Height 10mm, [714391](#) for Stack Height 12mm, [714392](#) for Stack Height 13mm, [714393](#) for Stack Height 15mm

Solder Process Data

Lead-free Process Capability
Process Temperature max. C

Reflow Capable (SMT only)
260

Material Info**Reference - Drawing Numbers**

Product Specification
Sales Drawing

PS-71436-9999
SDA-71436-2***

This document was generated on 03/31/2010

PLEASE CHECK WWW.MOLEX.COM FOR LATEST PART INFORMATION

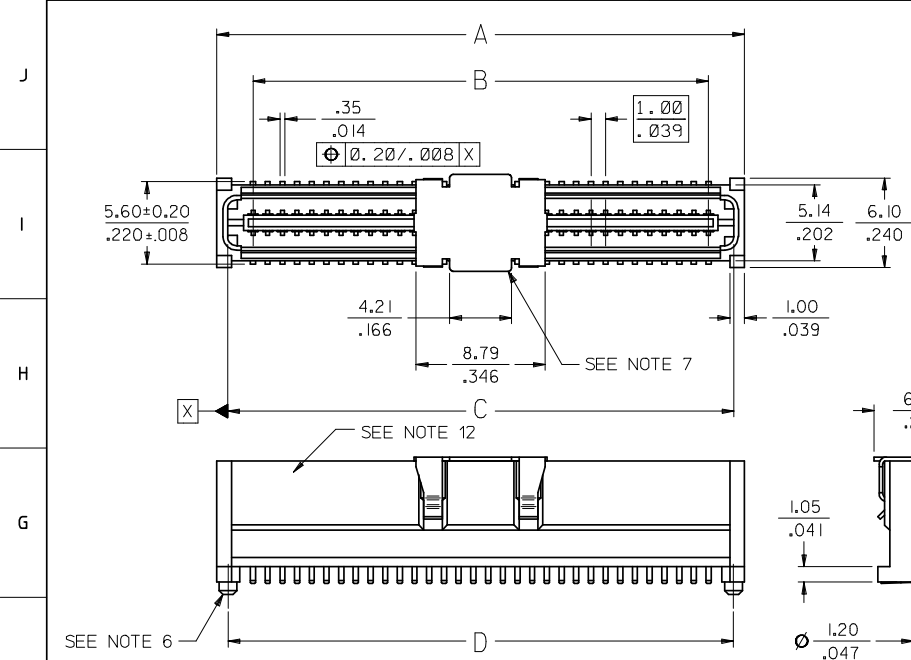

CIRCUIT SIZE	DIM. A	DIM. B	DIM. C	DIM. D
20	$\frac{13.90}{.547}$	$\frac{9.00}{.354}$	$\frac{12.58}{.495}$	$\frac{12.40}{.488}$
30	$\frac{18.90}{.744}$	$\frac{14.00}{.551}$	$\frac{17.58}{.692}$	$\frac{17.40}{.685}$
40	$\frac{23.90}{.941}$	$\frac{19.00}{.748}$	$\frac{22.58}{.889}$	$\frac{22.40}{.882}$
50	$\frac{28.90}{1.138}$	$\frac{24.00}{.945}$	$\frac{27.58}{1.086}$	$\frac{27.40}{1.079}$
60	$\frac{33.90}{1.335}$	$\frac{29.00}{1.142}$	$\frac{32.58}{1.283}$	$\frac{32.40}{1.276}$
64	$\frac{35.90}{1.413}$	$\frac{31.00}{1.220}$	$\frac{34.58}{1.361}$	$\frac{34.40}{1.354}$
70	$\frac{38.90}{1.531}$	$\frac{34.00}{1.339}$	$\frac{37.58}{1.480}$	$\frac{37.40}{1.472}$
80	$\frac{43.90}{1.728}$	$\frac{39.00}{1.535}$	$\frac{42.58}{1.676}$	$\frac{42.40}{1.669}$
84	$\frac{45.90}{1.807}$	$\frac{41.00}{1.614}$	$\frac{44.58}{1.755}$	$\frac{44.40}{1.748}$
90	$\frac{48.90}{1.925}$	$\frac{44.00}{1.732}$	$\frac{47.58}{1.873}$	$\frac{47.40}{1.866}$
100	$\frac{53.90}{2.122}$	$\frac{49.00}{1.929}$	$\frac{52.58}{2.070}$	$\frac{52.40}{2.063}$
110	$\frac{58.90}{2.319}$	$\frac{54.00}{2.126}$	$\frac{57.58}{2.267}$	$\frac{57.40}{2.260}$
120	$\frac{63.90}{2.516}$	$\frac{59.00}{2.323}$	$\frac{62.58}{2.464}$	$\frac{62.40}{2.457}$

NOTES:

- HOUSING MATERIAL: LIQUID CRYSTAL POLYMER (LCP) GLASS FILLED.; UL RATING: 94V-0; COLOR: WHITE OR BLACK
TERMINAL MATERIAL: PHOSPHOR BRONZE; 0.205/.0080 THICK
VACUUM CAP MATERIAL: STAINLESS STEEL; 0.255/.0100 THICK
- PLATING FINISHES: SEE SHEET 2
- PRODUCT SPECIFICATION: PS-71436-999
- PACKAGING SPECIFICATIONS: REFER TO CHART ON SHEET 2.
- MATES WITH: 71439 SERIES. SEE SHEET 2 FOR MATING VIEW AND STACK HEIGHT.
- PEGS ARE OPTIONAL. REFER TO CHART ON SHEET 2.
- VACUUM PICK & PLACE CAP IS OPTIONAL. REFER TO CHART ON SHEET 2.
- THIS PART CONFORMS TO EIA STANDARD 700 AAAB FOR 1.0mm TWO-PART CONNECTORS FOR USE WITH PARALLEL PRINTED BOARDS.
- COPLANARITY OF SMT TAILS: 0.10/.004 MAX.
- 64-CIRCUIT PLUG ASSEMBLY WITH PEGS AND VACUUM CAP SHOWN FOR ILLUSTRATION PURPOSES ONLY.
- DIMENSIONS ARE IN mm/in. INCH DIMENSIONS SHOWN FOR REFERENCE ONLY.
- ASSEMBLY TO HAVE DATE CODE: XX XX
WEEK _____ YEAR

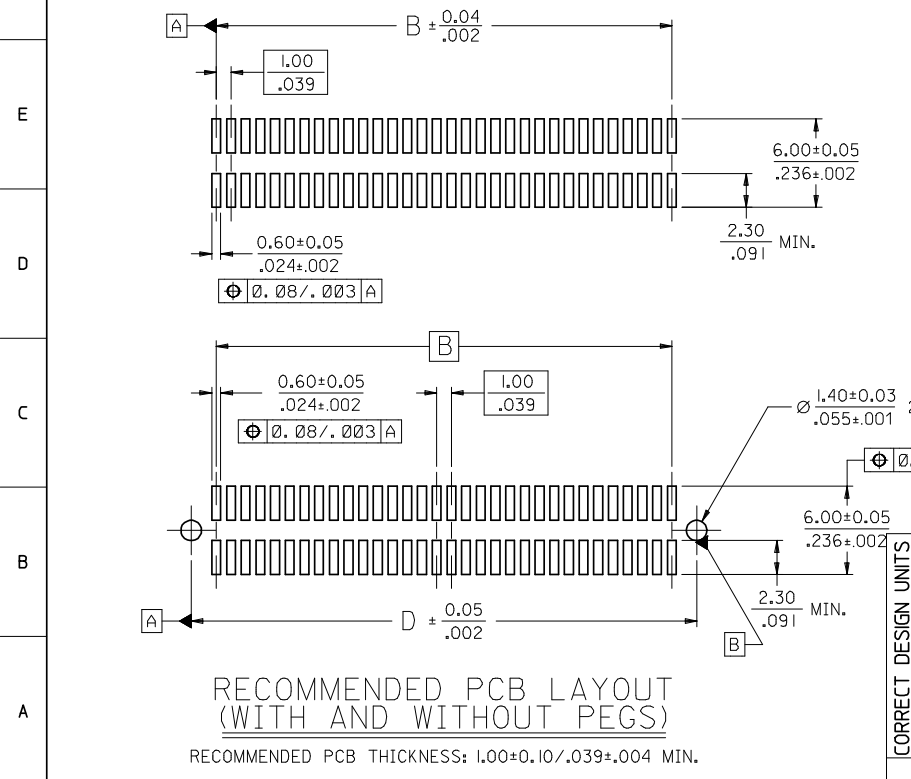

RECOMMENDED PCB LAYOUT (WITH AND WITHOUT PEGS)
RECOMMENDED PCB THICKNESS: 1.00±0.10/.039±.004 MIN.

2	L
1	M
SHT	REV

CORRECT DESIGN UNITS EC NO: UCP2008-2464 DRW:MSI/BARRA 2008/04/07 CHKD:BBARKER 2008/04/16 APPR:SMILLER 2008/04/16	QUALITY SYMBOLS ▽=0 ▽=0	GENERAL TOLERANCES (UNLESS SPECIFIED)	DIMENSION STYLE MM/IN	SCALE 4:1	DESIGN UNITS METRIC	THIRD ANGLE PROJECTION	
	4 PLACES ± --- ± ---	REED 1995/03/23	DRAWN BY REED	DATE 1995/03/23	TITLE SALES ASSY, 1.0MM BOARD TO BOARD PLUG CONNECTOR 4.30/169 STACK HEIGHT		
	3 PLACES ± --- ± .005	CHECKED BY REED	DATE 1995/07/23	MATERIAL NO. SEE TABLE			
	2 PLACES ± 0.13 ± .01	APPROVED BY BIXLER	DATE 1995/03/23	DOCUMENT NO. SDA-71436-2***			
1 PLACE ± 0.25 ± ---	ANGULAR ±1/2°		DRAFT WHERE APPLICABLE MUST REMAIN WITHIN DIMENSIONS		SHEET NO. 1 OF 2		
THIS DRAWING CONTAINS INFORMATION THAT IS PROPRIETARY TO MOLEX INCORPORATED AND SHOULD NOT BE USED WITHOUT WRITTEN PERMISSION							

WHITE (NATURAL) MATERIAL

CIRCUIT SIZE	PLUG ASSEMBLY ITEM NUMBER	PEGS	CONTACT PLATING (SEE PLATING NOTES)	PICK & PLACE CAP	PACKAGING SPEC. NUMBER	PACKAGING TYPE
64	71436-2164	YES	30 GOLD	NO	PK-70873-0607	TUBE
64	71436-2364	YES	30 GOLD	YES	PK-70873-0607	TUBE
64	71436-2464	YES	30 GOLD	YES	PK-70873-063	TAPE & REEL
64	71436-2564	NO	30 GOLD	NO	PK-70873-0606	TUBE
64	71436-2764	NO	30 GOLD	YES	PK-70873-0606	TUBE
64	71436-2864	NO	30 GOLD	YES	PK-70873-063	TAPE & REEL
64	71436-2264	NO	50 GOLD	YES	PK-70873-063	TAPE & REEL
64	71436-2664	YES	50 GOLD	NO	PK-70873-0607	TUBE
64	71436-2064	NO	50 GOLD	NO	PK-70873-0607	TUBE

PLATING NOTES:

30 GOLD: SELECTIVE GOLD (Au) IN THE CONTACT AREA;
 THICKNESS = 0.76 MICROMETERS (30 MICROINCHES) MINIMUM;
 SELECTIVE TIN (Sn) IN THE PC TAIL AREA;
 THICKNESS = 1.88 MICROMETERS (75 MICROINCHES) MINIMUM;
 NICKEL UNDERPLATE OVERALL.

50 GOLD: SELECTIVE GOLD (Au) IN THE CONTACT AREA;
 THICKNESS = 1.27 MICROMETERS (50 MICROINCHES) MINIMUM;
 SELECTIVE TIN (Sn) IN THE PC TAIL AREA;
 THICKNESS = 1.88 MICROMETERS (75 MICROINCHES) MINIMUM;
 NICKEL UNDERPLATE OVERALL.

BLACK MATERIAL WITH PICK & PLACE CAP

CIRCUIT SIZE	PLUG ASSEMBLY ITEM NUMBER	PEGS	CONTACT PLATING (SEE NOTES PAGE2)	PICK & PLACE CAP	PACKAGING SPEC. NUMBER	PACKAGING TYPE
64	71436-2964	NO	30 GOLD	YES	PK-70873-063	TAPE & REEL

RECOMMENDED PLUG/RECEPTACLE COMBINATION FOR MATED STACK HEIGHT PER EIA STANDARD 700 AAAB

MATED STACK HEIGHT	RECEPTACLE HEIGHT	RECEPTACLE SERIES NO.	PLUG HEIGHT	PLUG SERIES NO.
10.00/.394	5.30/.209	71439-0***	4.30/.169	71436-2***
12.00/.472	7.30/.287	71439-1***	4.30/.169	71436-2***
13.00/.512	8.30/.327	71439-2***	4.30/.169	71436-2***
15.00/.591	10.30/.406	71439-3***	4.30/.169	71436-2***

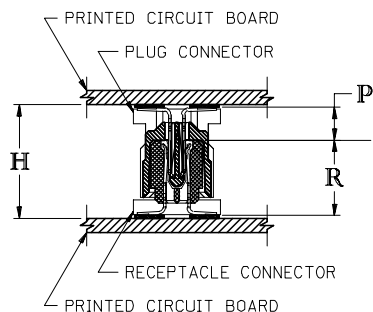

PLUG STACK HEIGHT
 + RECEPTACLE STACK HEIGHT
 + 0.40/.016 (SOLDER PASTE ALLOWANCE)
 = MATED STACK HEIGHT

BOTTOMING SURFACE

P = PLUG STACK HEIGHT
 R = RECEPTACLE STACK HEIGHT
 H = MATED STACK HEIGHT

ADD 71436-2064/-2664 EC NO: UCP2007-2420 DRWN:MSIBARRA 2007/05/08 CHKD:DMORGAN 2007/05/17 APPR:SMILLER 2007/05/18 REVISIONS	QUALITY SYMBOLS ▽=0 ▽=0	GENERAL TOLERANCES (UNLESS SPECIFIED) mm INCH 4 PLACES ± --- ± --- 3 PLACES ± --- ± --- 2 PLACES ± --- ± --- 1 PLACE ± --- ± --- ANGULAR ±1/2°	DIMENSION STYLE MM/IN DRAWN BY DATE REED 1995/03/23 CHECKED BY DATE REED 1995/03/23 APPROVED BY DATE BIXLER 1995/03/23	SCALE --- DESIGN UNITS INCH THIRD ANGLE PROJECTION	TITLE SALES ASSY, 1.0MM BOARD TO BOARD PLUG CONNECTOR 4.30/.169 STACK HEIGHT MOLEX INCORPORATED MATERIAL NO. SDA-71436-2*** DOCUMENT NO. SDA-71436-2*** SHEET NO. 2 OF 2
	DRAFT WHERE APPLICABLE MUST REMAIN WITHIN DIMENSIONS		SEE TABLE		THIS DRAWING CONTAINS INFORMATION THAT IS PROPRIETARY TO MOLEX INCORPORATED AND SHOULD NOT BE USED WITHOUT WRITTEN PERMISSION