

| SPECIFICATIONS                                       |              |       |
|--|--------------|-------|
| PARAMETERS   | VALUES       | UNITS |
| RATED INPUT POWER                                    | 2            | W     |
| MAX INPUT POWER                                      | 4            | W     |
| IMPEDANCE  | 4 ± 15%      | OHM   |
| OUTPUT SPL @ 1W/0.5M<br>(AT 0.8, 1.0, 1.2, 1.5, kHz) | 87 ± 3       | dB(A) |
| DISTORTION (MAX.)                                    | 5%           | -     |
| RESONANT FREQUENCY                                   | 370 ± 20%    | Hz    |
| FREQUENCY RANGE                                      | 200 ~ 20,000 | Hz    |
| HOUSING MATERIAL                                     | ABS          | -     |
| CONE MATERIAL  | PAPER        | -     |
| MAGNET MATERIAL                                      | Nd-Fe-B      | -     |
| OPERATING TEMPERATURE                                | -40 ~ +85    | °C    |
| WEIGHT   | 16.5         | grams |

THIS DOCUMENT CONTAINS DATA PROPRIETARY TO PROJECTS UNLIMITED, INC. ANY USE OR REPRODUCTION, IN ANY FORM, WITHOUT PRIOR WRITTEN PERMISSION OF PROJECTS UNLIMITED, INC. IS PROHIBITED.  
©2003, Projects Unlimited Inc.

| REVISION HISTORY |  |            |          |
|------------------|--|------------|----------|
| LTR              | DESCRIPTION                              | DATE       | APPROVED |
| -                | RELEASED FROM ENGINEERING                | 12/7/2005  |          |
| A                | ADDED MOUNTING HOLE DIMENSION            | 12/18/2007 | R.W.     |
| B                | REVISED MAX. INPUT POWER                 | 7/18/2008  | B.R.     |
| C                | REVISED OPERATING TEMPERATURE            | 10/14/2008 | C.W.     |
| D                | REVISED TO INVENTOR 3-D DRAWING TEMPLATE | 11/8/2008  | B.R.     |

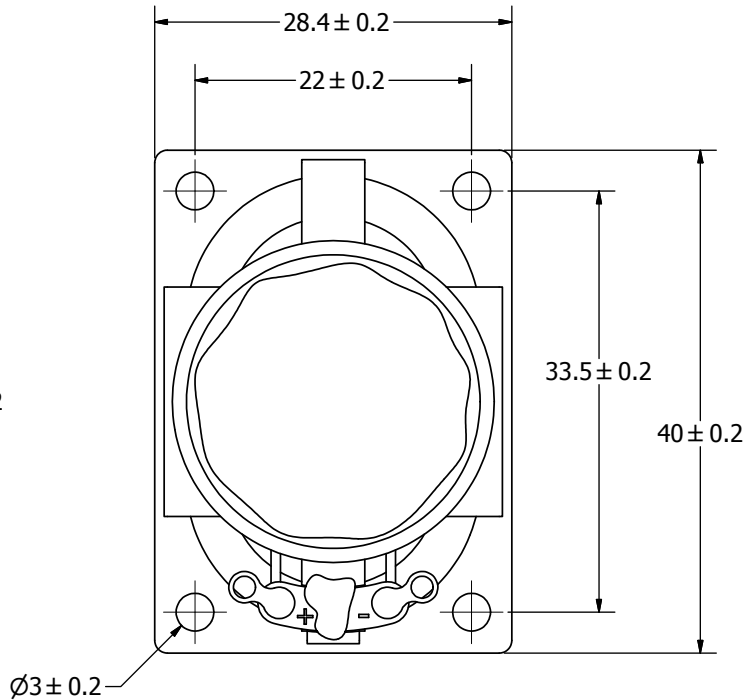
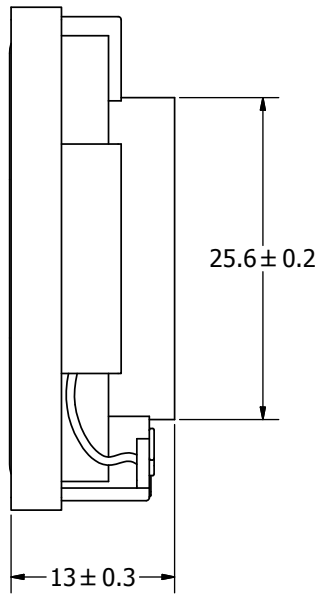

**NOTES:**

1. ALL DIMENSIONS ARE IN MILLIMETERS.
2. SPECIFICATIONS SUBJECT TO CHANGE OR WITHDRAWAL WITHOUT NOTICE.
3. THIS PART IS RoHS 2002/95/EC COMPLIANT.

|  |                   |                                      |           |            |           |             |           |            |
|--|-------------------|--------------------------------------|-----------|------------|-----------|-------------|-----------|------------|
| UNLESS OTHERWISE SPECIFIED:<br>DIMENSIONS ARE IN MILLIMETERS,<br>TOLERANCES ARE ±0.5 AND ANGLES ARE ±3°. | SIZE<br><b>A3</b> | Designed by                          | Date      | Checked by | Date      | Approved by | Date      | Drawn Date |
|  |                   | J.A.F.                               | 12/6/2005 | B.R.       | 12/7/2005 | E.P.        | 12/7/2005 | 11/8/2008  |
| AS04004PO-R.idw  |                   | <br>A Division of Projects Unlimited |           |            |           | AS04004PO-R |           |            |
| Speaker  |                   |                                      |           |            |           | Edition     | Sheet     |            |
|  |                   |                                      | -         |            |           | 1 / 1       |           |            |