

NEW

Radiometrix

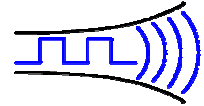

Hartcran House, 231 Kenton Lane, Harrow, HA3 8RP, England

Tel: +44 (0) 20 8909 9595, Fax: +44 (0) 20 8909 2233

08 January 2008

TX3H-869.50-10

UHF Wide Band FM 450mW Transmitter

The TX3H-869.5-10 is an 869.5MHz FM transmitter module with a power output of 450mW nominal. It is a 100% pin-compatible drop-in replacement for the Radiometrix TX1H-151.300-10 and can be used in applications where greater radiated power is desired (for example when space limitations dictate the use of small and inefficient antennas, or for applications where the extra power is permitted). The module will handle raw data rates up to 10kbps.



Figure 1: TX3H-869.50-10 & RX3A-869.50-10

Features

- Standard frequency: 869.50MHz band
- Data rates up to 16kbps
- Usable range over 3km
- Fully screened
- Low power requirements

The TX3H operates on European 869.40 – 869.65MHz sub-band allocation for 500mW and is designed to meet EN300 200-3 (radio) and EN301 489-3 (EMC) requirements. Custom frequencies may be available to order.

Technical Summary

- Transmit power: 450mW (26.5dBm, ± 1 dB)
- Operating frequency: 869.50MHz
- Supply: 5V (regulated)
- Current consumption: 310mA (typical)
- Data bit rate: 16kbps max.
- Size: 45 x 17 x 5.5mm

Applications

- Tracing and asset tracking systems
- Meter reading systems
- Industrial telemetry and telecommand
- Data loggers
- In-building environmental monitoring and control
- Social alarms
- High-end security and fire alarms
- Vehicle data up/download

TX3H single channel 450mW UHF transmitter

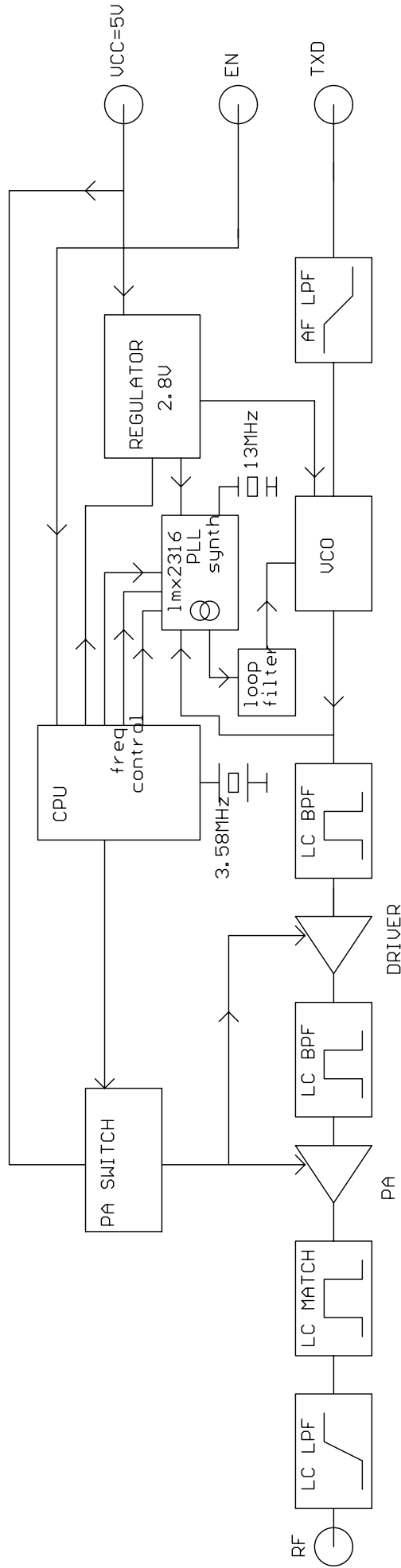

Figure 2: TX3H block diagram

User interface

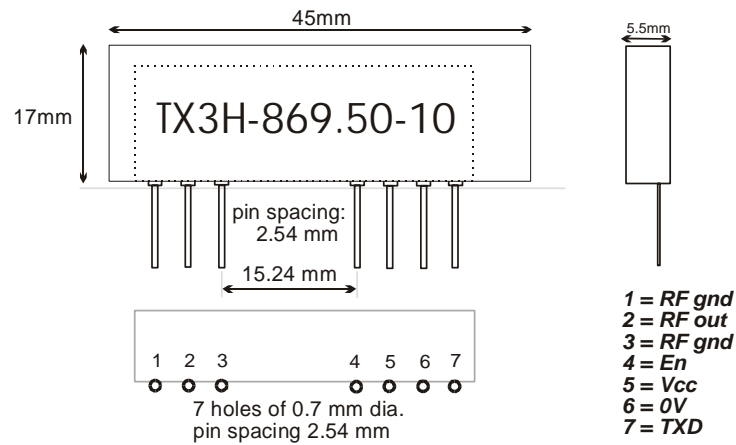

Figure 3: TX3H pin-out and dimension (compared to TX3A)

TX1H pin	Name	Function
1, 3	RFgnd	RF Ground
2	RF out	50Ω RF output to the antenna
4	EN	Pull high to enable TX. <0.15V shuts down module (current <1μA).
5	VCC	5V regulated DC power supply
6	0V	Ground
7	TXD	DC coupled input for 5V CMOS logic. $R_{in} = 100k\Omega$

Note: Pin out as TX1H and standard TX3A

Condensed specifications:

Operating temperature: -40°C to +85°C

(Figures apply at +25°C, 5.0V supply unless otherwise stated)

	pin	min.	typ.	max.	units	notes
Supply						
Supply voltage	5	4.9	5	5.1	V	8
Supply current	5	-	310	-	mA	
Standby current (EN <0.15V)	5	-	-	1	μA	8
RF						
RF power output	2	+25.5	+26.5	+27	dBm	1
Spurious emissions, ≤1GHz	2	-	-	-54	dBm	2
Spurious emissions, ≥ 1GHz	2	-	-	-40	dBm	2
RF centre frequency		-	869.50	-	MHz	3
Initial Frequency accuracy		-15	0	+15	kHz	
Overall Frequency accuracy		-40	0	+40	kHz	4
FM deviation (peak)		-	±27	-	kHz	5
Antenna pin impedance	2	-	50	-	Ω	
Number of channels		-	1	-		
Baseband						
Modulation bandwidth @ -3dB		DC	-	8	kHz	6
Maximum raw data rate		-	-	16	kbps	6
TXD input level (logic low)	6	-	0	-	V	7
TXD input level (logic high)	6	-	5.0	-	V	7
Dynamic timing						
TX enable to full RF		-	53	55	ms	8

Notes:

1. Measured into 50Ω resistive load
2. Meets EN requirements at all frequencies
3. There is a <10% duty cycle restriction on 869.50 MHz in EU member states
4. Total over full supply and temperature range
5. With 0V – 5.0V modulation input
6. 5V CMOS compatible
7. To achieve specified FM deviation
8. Supply to Vcc must be constant and should not be used for power up of tx (use EN)

Applications information

Modulation formats

The module will produce the specified FM deviation with a 2-level digital input to TXD which toggles between 0V and 5V.

TXD is normally driven directly by logic levels but will also accept analogue drive, e.g. 2-tone signalling. In this case it is recommended that TXD (pin 7) should be DC-biased to 2.5V with the modulation AC-coupled and limited to a maximum of 5V peak-to-peak. The instantaneous modulation voltage must not swing below 0V or above 5V at any time if waveform distortion and excessive FM deviation is to be avoided – use a resistive potential divider and/or level shifter to accomplish this if necessary. The varactor modulator in the transmitter introduces some 2nd harmonic distortion, which may be reduced if necessary by predistortion of the analogue waveform.

At the other end of the link the AF output (pin 6) of RX3A receiver can be used to drive an external decoder directly.

Although the module baseband response extends down to DC, data formats containing a DC component are unsuitable and should not be used. This is because frequency errors and drifts between the transmitter and receiver occur in normal operation resulting in DC offset errors on the AF output.

Power up timing for TX3H

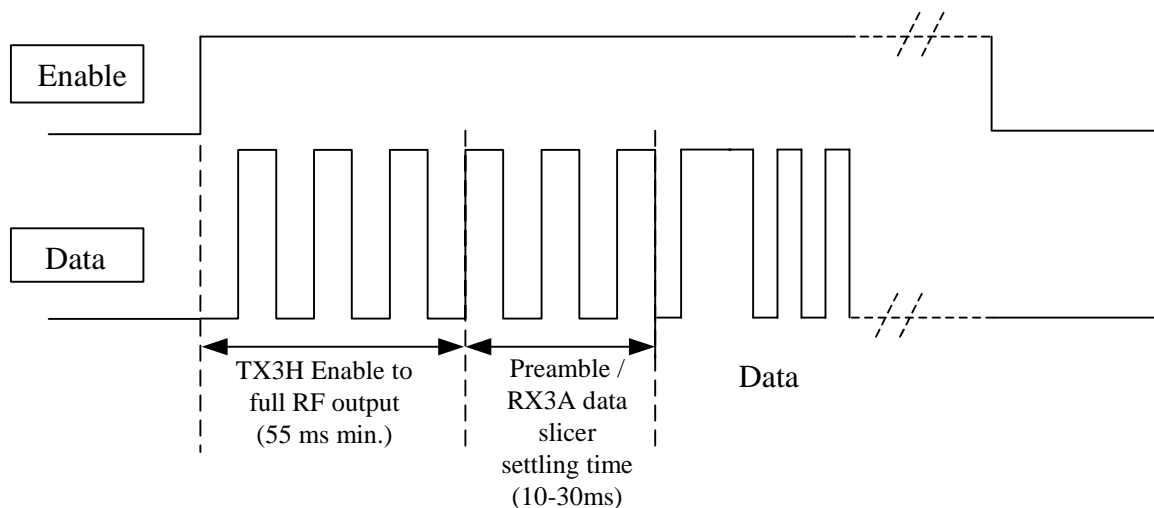

Figure 4: Typical timing diagram

Antenna considerations and options

The choice and positioning of transmitter and receiver antennas is of the utmost importance and is the single most significant factor in determining system range. The following notes are intended to assist the user in choosing the most effective arrangement for a given application.

Nearby conducting objects such as a PCB or battery can cause detuning or screening of the antenna which severely reduces efficiency. Ideally the antenna should stick out from the top of the product and be entirely in the clear, however this is often not desirable for practical or ergonomic reasons and a compromise may need to be reached. If an internal antenna must be used, try to keep it away from other metal components and pay particular attention to the “hot” end (i.e. the far end), as this is generally the most susceptible to detuning. The space around the antenna is as important as the antenna itself.

Microprocessors and microcontrollers tend to radiate significant amounts of radio frequency hash, which can cause desensitisation of the receiver if its antenna is in close proximity. 868MHz band is generally less prone to this effect than lower frequencies, but problems can still arise. Things become

worse as logic speeds increase, because fast logic edges are capable of generating harmonics across the UHF range which are then radiated effectively by the PCB tracking. In extreme cases system range can be reduced by a factor of 3 or more. To minimise any adverse effects, situate the antenna and module as far as possible from any such circuitry and keep PCB track lengths to the minimum possible. A ground plane can be highly effective in cutting radiated interference and its use is strongly recommended. A simple test for interference is to monitor the receiver RSSI output voltage, which should be the same regardless of whether the microcontroller or other logic circuitry is running or in reset.

Two types of antenna are recommended for use with the TX3H:

Whip (¼-wave). This consists simply of a piece of wire or rod connected to the module at one end. The lengths given below are from module pin to antenna tip including any interconnecting wire or tracking (but not including any 50Ω coax or microstrip connection). This antenna is simple, cheap, easy to set up and performs well. It is especially effective when used with a ground plane, which in practice is often provided by the main PCB or by a metal case.

Base-loaded whip. In applications where space is at a premium a shortened whip may be used, tuned by means of a coil inserted at the base. This coil may be air-wound for maximum efficiency, or a small SMT inductor can be used. The value must be empirically chosen to tune the particular length of whip for best results “in situ”, making this antenna more difficult to set up. Radiated power will generally be slightly less than that obtained from a ¼-wave whip.

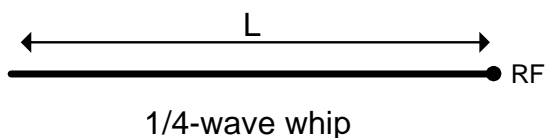

wire, rod, PCB track
or a combination of these
 $L \text{ (mm)} = 71250 / \text{freq(MHz)}$

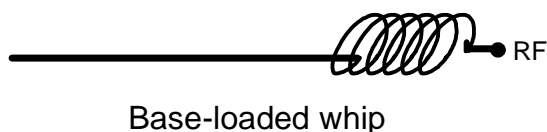

shortened wire, rod, PCB track etc.
with loading coil.
SMT inductor may be used if reqd.

Fig. 5: Antenna configurations

Other types of antennas are feasible but tend to have drawbacks at these frequencies. Helical and tuned loop antennas are both very compact but tricky to set up, and can be impractical at 868MHz because of their very small size. Microstrip patch antennas are relatively large in area, directional, and have gain.

Note: Where the specified antennas are mounted on the PCB and/or in close proximity to metalwork (module casing, components, PCB tracking etc), the antenna radiation pattern may be seriously affected. Radiated power may be significantly increased in some directions (sometimes by as much as 10dB) and correspondingly reduced in others. This may adversely affect system performance where good all-round coverage is desired.

Care should also be taken to ensure that this effect does not increase the radiated power in any direction beyond that allowed by type approval regulations. Where this occurs the antenna may need to be relocated. In extreme cases a resistive attenuator of appropriate value may be required between the module and antenna.

Type Approval requirements: Europe

The modules comply with the requirements of the R&TTE Directive (including standards EN 300 220-3 and EN 301 489-3) when used in accordance with the information contained herein. The following provisos apply:

- 1) The modules must not be modified or used outside their specification limits.
- 2) The modules may only be used to transfer digital or digitised data. Analogue speech and/or music are not permitted.
- 3) The equipment in which the TX3H is used must carry all necessary external labelling to meet the requirements of the R&TTE directive.
- 4) The TX3H has not been tested with antennas having gains greater than that of a quarter-wave whip. The use of such antennas may require further R&TTE approval.

Module mounting considerations

Good RF layout practice should be observed. In particular, any ground return required by the antenna or feed should be connected directly to the RF GND pins at the antenna end of the module, and not to the 0V pins which are intended as DC grounds only. All connecting tracks should be kept as short as possible to avoid any problems with stray RF pickup.

If the connection between module and antenna does not form part of the antenna itself, it should be made using 50 Ω microstrip line or coax or a combination of both. It is desirable (but not essential) to fill all unused PCB area around the module with ground plane.

Ordering information

For European applications in the 868 - 870MHz band:

Transmitter: **TX3H-869.50-10**

Matching RX3A receiver: **RX3A-869.50-10**

(Refer to TX3A/RX3A data sheet for technical details: <http://www.radiometrix.com/pdf/tx3arx3a.pdf>)

CEPT/ERC Rec 70-03, 868 MHz Band Plan

Applications	Non-specific SRD	Alarm	Non-specific SRD	Social Alarm	Alarm	Non-specific SRD	Alarm	Non-specific SRD
Channel Spacing	No Spacing	25kHz or WB	No Spacing	25kHz	25kHz	25kHz or Wide Band	25kHz	No Spacing
Duty Cycle	<1% or LBT	<1%	<0.1% or LBT	<0.1%	<0.1%	<10% or LBT	<10%	up to 100%

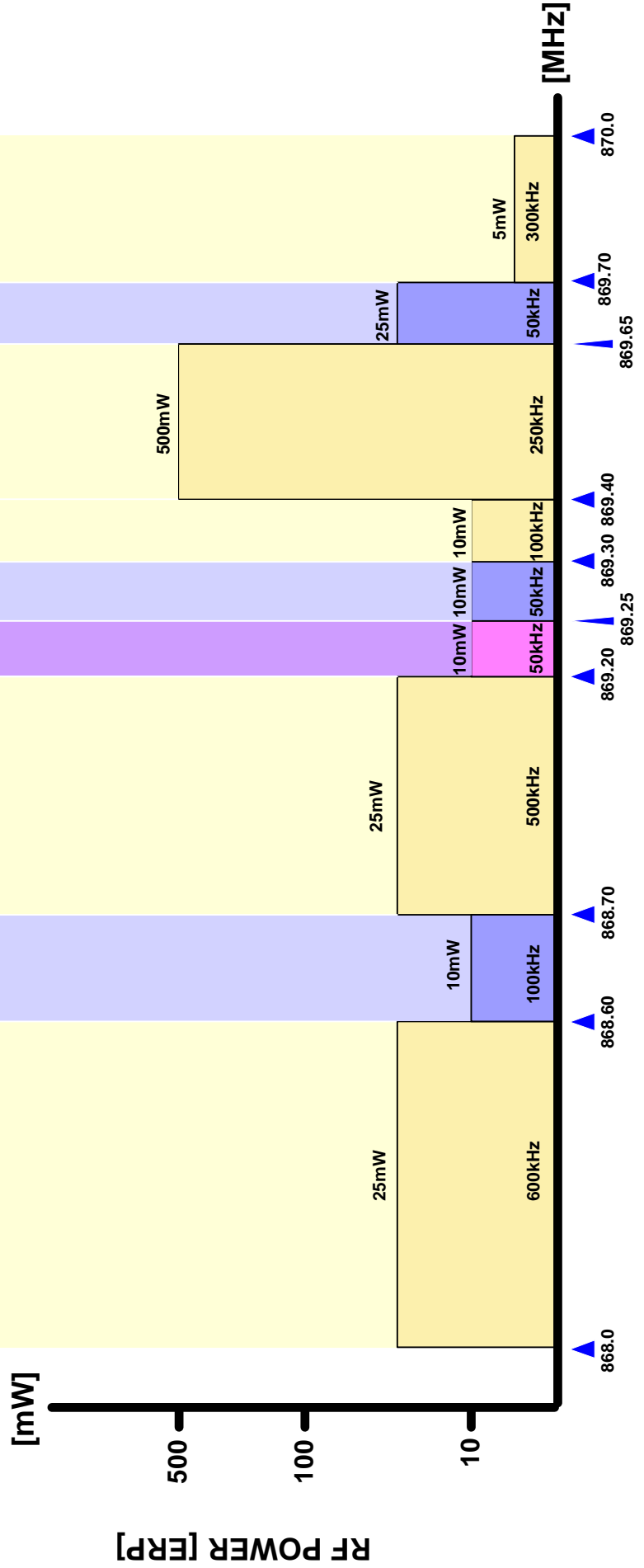

Radiometrix Ltd

**Hartcran House
231 Kenton Lane
Harrow, Middlesex
HA3 8RP
ENGLAND**

Tel: +44 (0) 20 8909 9595

Fax: +44 (0) 20 8909 2233

sales@radiometrix.com

www.radiometrix.com

Copyright notice

This product data sheet is the original work and copyrighted property of Radiometrix Ltd. Reproduction in whole or in part must give clear acknowledgement to the copyright owner.

Limitation of liability

The information furnished by Radiometrix Ltd is believed to be accurate and reliable. Radiometrix Ltd reserves the right to make changes or improvements in the design, specification or manufacture of its subassembly products without notice. Radiometrix Ltd does not assume any liability arising from the application or use of any product or circuit described herein, nor for any infringements of patents or other rights of third parties which may result from the use of its products. This data sheet neither states nor implies warranty of any kind, including fitness for any particular application. These radio devices may be subject to radio interference and may not function as intended if interference is present. We do NOT recommend their use for life critical applications.

The Intrastat commodity code for all our modules is: 8542 6000

R&TTE Directive

After 7 April 2001 the manufacturer can only place finished product on the market under the provisions of the R&TTE Directive. Equipment within the scope of the R&TTE Directive may demonstrate compliance to the essential requirements specified in Article 3 of the Directive, as appropriate to the particular equipment. Further details are available on The Office of Communications (Ofcom) web site:

<http://www.ofcom.org.uk/radiocomms/ifi/>

Information Requests

Ofcom

Riverside House

2a Southwark Bridge Road

London SE1 9HA

Tel: +44 (0)845 456 3000 or 020 7981 3040

Fax: +44 (0)20 7783 4033

information.requests@ofcom.org.uk

European Radiocommunications Office (ERO)

Peblingehus

Nansensgade 19

DK 1366 Copenhagen

Tel. +45 33896300

Fax +45 33896330

ero@ero.dk

www.ero.dk
