

E

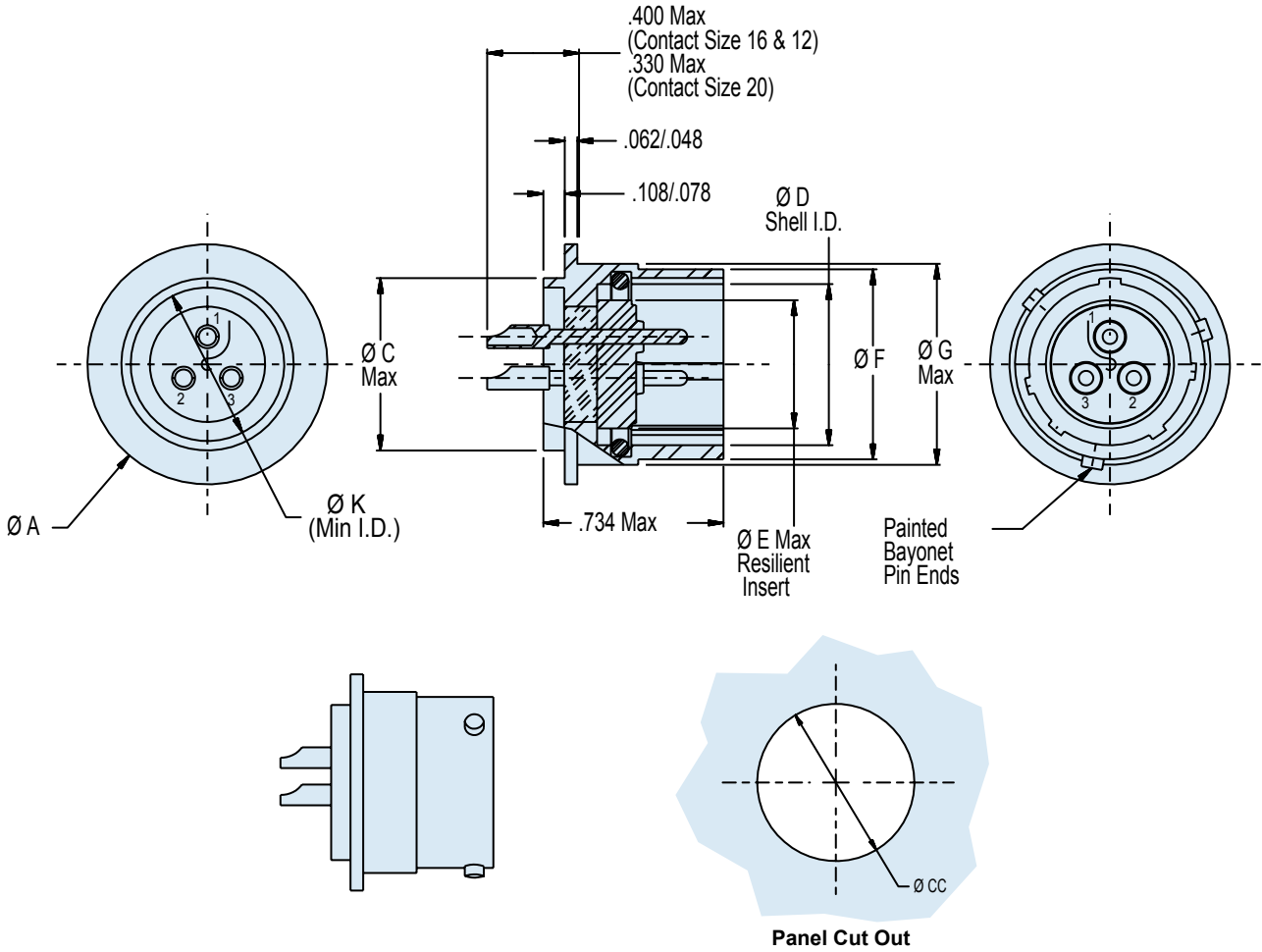

230-024

# MIL-DTL-83723/80 Series III Type Hermetic Bayonet Coupling Solder Flange Mount Receptacle with Solder Cup Terminals

MIL-DTL  
83723

## HERMETIC LEAK RATE MOD CODES

Designator	Required Leak Rate
-585A	1 x 10 <sup>-10</sup> cc's Helium per second
-585B	1 x 10 <sup>-9</sup> cc's Helium per second
-585C	1 x 10 <sup>-8</sup> cc's Helium per second

TABLE I: CONNECTOR AND CUT-OUT DIMENSIONS

Shell Size	A	C Dia Max	D Dia Shell I.D.	E Dia Resilient Insert	F Dia	G Dia Max	K Dia Min	Panel Cut-Out Ø CC
8	.760/.720 (19.3/18.3)	.500 (12.7)	.433/.428 (11.0/10.9)	.312 (7.9)	.536/.531 (13.6/13.5)	.561 (14.2)	.406 (10.3)	.515/.505 (13.1/12.8)
10	.860/.820 (21.8/20.8)	.562 (14.3)	.535/.530 (13.6/13.5)	.388 (9.9)	.659/.654 (16.7/16.6)	.696 (17.7)	.443 (11.3)	.582/.572 (14.8/14.5)
12	1.065/1.025 (27.1/26.0)	.750 (19.1)	.705/.700 (17.9/17.8)	.558 (14.2)	.829/.824 (21.1/20.9)	.875 (22.2)	.668 (17.0)	.770/.760 (19.6/19.3)
14	1.110/1.070 (28.2/27.2)	.812 (20.6)	.774/.796 (19.7/20.2)	.627 (15.9)	.898/.893 (22.8/22.7)	.935 (23.7)	.668 (17.0)	.832/.822 (21.1/20.9)
16	1.230/1.190 (31.2/30.2)	.937 (23.8)	.901/.896 (22.9/22.8)	.772 (19.6)	1.025/1.020 (26.0/25.9)	1.062 (27.0)	.763 (19.4)	.958/.948 (24.3/24.1)
18	1.360/1.320 (34.5/33.5)	1.062 (27.0)	1.007/1.002 (25.6/25.5)	.860 (21.8)	1.131/1.126 (28.7/28.6)	1.187 (30.1)	.862 (21.9)	1.082/1.072 (27.5/27.2)
20	1.450/1.410 (36.8/35.8)	1.187 (30.1)	1.132/1.125 (28.8/28.6)	.985 (25.0)	1.256/1.251 (31.9/31.8)	1.312 (33.3)	1.108 (28.1)	1.202/1.192 (30.5/30.3)
22	1.610/1.570 (40.9/39.9)	1.312 (33.3)	1.257/1.252 (31.9/31.8)	1.110 (28.2)	1.381/1.376 (35.1/35.0)	1.437 (36.5)	1.204 (30.6)	1.332/1.322 (33.8/33.6)
24	1.730/1.690 (43.9/42.9)	1.437 (36.5)	1.382/1.377 (35.1/35.0)	1.235 (31.4)	1.506/1.501 (38.3/38.1)	1.562 (39.7)	1.388 (35.3)	1.452/1.442 (36.9/36.6)

E

## APPLICATION NOTES

- To be identified with manufacturer's name, part number and date code, space permitting.
- Material/Finish\*:
  - Shell:
    - Z1 - Stainless steel/passivated
    - ZL - Stainless steel/Nickel Plated
    - FT - Carbon steel/tin plated
  - Contacts - 52 Nickel alloy/gold plated
  - Bayonets - Stainless steel/passivated
  - Seals - Silicone elastomer/N.A.
  - Insulation - Glass/N.A.
- Glenair 230-024 will mate with any QPL MIL-DTL-83723/75 & 77 Series III bayonet coupling plug of same size, keyway, and insert polarization.
- Performance:
  - Hermeticity <1 x 10<sup>-7</sup> cc He/sec @ 1 atmosphere differential.
  - Dielectric withstanding voltage - Consult factory or MIL-STD-1554.
  - Insulation resistance - 5000 MegOhms min @ 500VDC.
- Consult factory and/or MIL-STD-1554 for arrangement, keyway, and insert position options.
- Metric Dimensions (mm) are indicated in parentheses.

\* Additional shell materials available, including titanium and Inconel®. Consult factory for ordering information.