

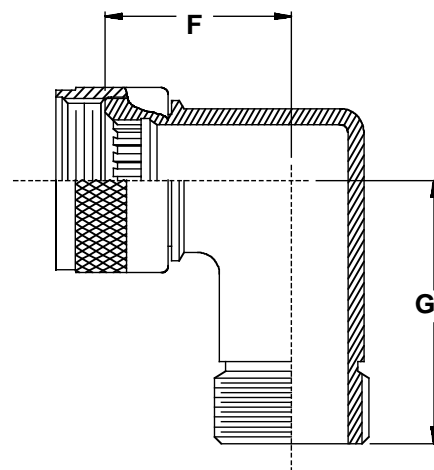

713-102 Metal Straight, 45°, and 90° M28840 Connector Adapters for Series 72 & 74 Tubing and Series 75 Conduit

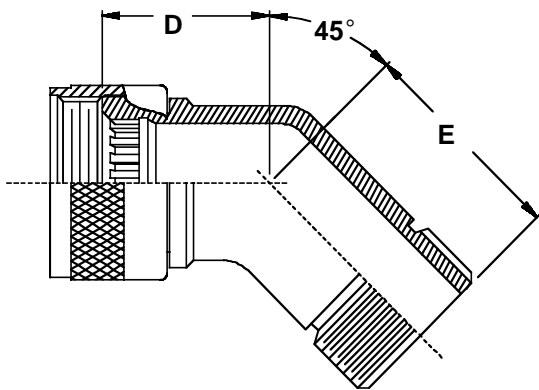
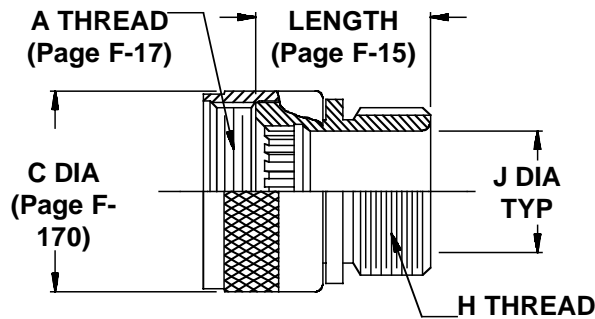
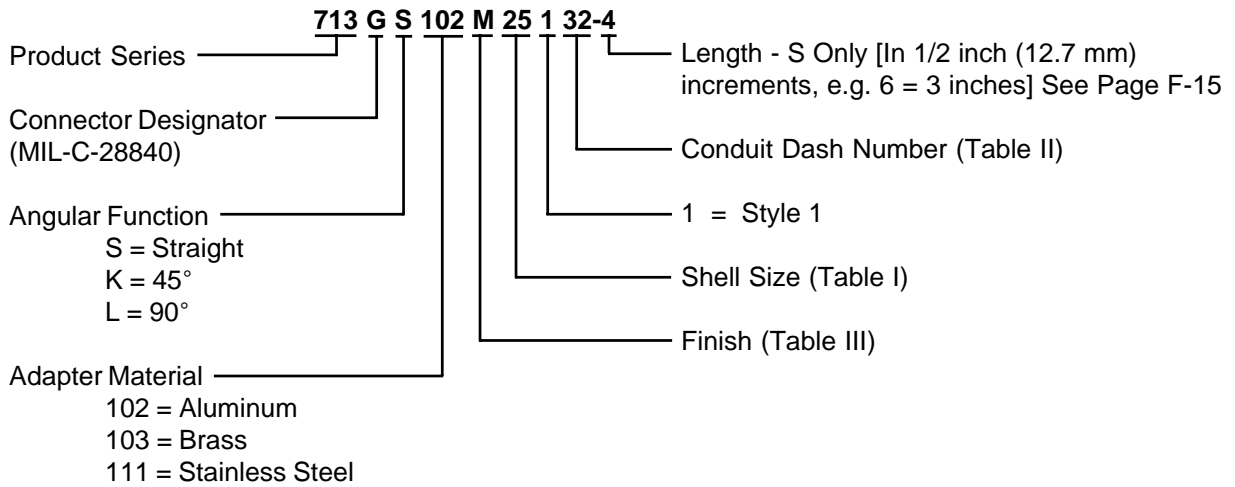

Metric dimensions (mm) are in parentheses.

713-102
Metal Straight, 45°, and 90° M28840 Connector Adapters
for Series 72 & 74 Tubing and Series 75 Conduit



TABLE I

SHELL SIZE MIL-C-28840	MAX CONDUIT DASH NO.	D MAX	E MAX	F MAX	G MAX
	REF *				
11	12	1.240 (31.5)	.920 (23.4)	1.380 (35.1)	1.060 (26.9)
13	16	1.260 (32.0)	.940 (23.9)	1.440 (36.6)	1.120 (28.4)
15	20	1.290 (32.8)	.970 (24.6)	1.500 (38.1)	1.190 (30.2)
17	24	1.310 (33.3)	.990 (25.1)	1.570 (39.9)	1.250 (31.8)
19	24	1.340 (34.0)	1.020 (25.9)	1.630 (41.4)	1.330 (33.8)
23	32	1.380 (35.1)	1.060 (26.9)	1.730 (43.9)	1.410 (35.8)
25	40	1.410 (35.8)	1.090 (27.7)	1.800 (45.7)	1.480 (37.6)
29	48	1.580 (40.1)	1.260 (32.0)	2.040 (51.8)	1.720 (43.7)
33	48	1.620 (41.1)	1.300 (33.0)	2.130 (54.1)	1.810 (46.0)

* Dimensions D-E-F-G apply to connector shell size and conduit dash number combinations listed. When larger conduit dash numbers are selected, consult factory for dimensions.

TABLE II

CONDUIT DASH NO.	AVAILABILITY			H THREAD CLASS 2A	J DIA ± .015 (.4)
	72	74	75		
06		06		7/16 - 28 UNEF	.193 (4.9)
08			08	1/2 - 20 UNF	.255 (6.5)
09		09	09	9/16 - 24 UNEF	.286 (7.3)
10		10		9/16 - 24 UNEF	.317 (8.1)
12	12	12	12	5/8 - 24 UNEF	.380 (9.7)
14		14		11/16 - 24 UNEF	.442 (11.2)
16	16	16	16	3/4 - 20 UNEF	.505 (12.8)
20	20	20	20	7/8 - 20 UNEF	.630 (16.0)
24	24	24	24	1 - 20 UNEF	.755 (19.2)
28	28	28		1 3/16 - 18 UNEF	.880 (22.4)
32	32	32	32	1 5/16 - 18 UNEF	1.005 (25.5)
40	40	40	40	1 1/2 - 18 UNEF	1.255 (31.9)
48		48	48	1 3/4 - 18 UNS	1.505 (38.2)
56		56	56	2 - 18 UNS	1.755 (44.6)
64		64	64	2 1/4 - 16 UN	2.005 (50.9)

Consult factory for adapters using 3.000 inch (76.2) conduit

TABLE III

SYMBOL	FINISH
B	Olive Drab over Cadmium Plate
J	Gold Iridite over Cadmium Plate over Nickel
M	Electroless Nickel
N	Olive Drab over Cadmium Plate over Nickel
NC	Zinc-Cobalt, Olive Drab
NF	Olive Drab over Cadmium Plate over Electroless Nickel (500 Hour Salt Spray)
T	Bright Dip Cadmium Plate over Nickel
Z1	Passivate