

CMPT2907A
SURFACE MOUNT
PNP SILICON TRANSISTOR



SOT-23 CASE



www.centrasemi.com

DESCRIPTION:

The CENTRAL SEMICONDUCTOR CMPT2907A type is a PNP silicon transistor manufactured by the epitaxial planar process, epoxy molded in a surface mount package, designed for small signal general purpose and switching applications.

MARKING CODE: C2F

MAXIMUM RATINGS: ($T_A=25^\circ\text{C}$)

	SYMBOL		UNITS
Collector-Base Voltage	V_{CBO}	60	V
Collector-Emitter Voltage	V_{CEO}	60	V
Emitter-Base Voltage	V_{EBO}	5.0	V
Continuous Collector Current	I_C	600	mA
Power Dissipation	P_D	350	mW
Operating and Storage Junction Temperature	T_J, T_{stg}	-65 to +150	$^\circ\text{C}$
Thermal Resistance	θ_{JA}	357	$^\circ\text{C/W}$

ELECTRICAL CHARACTERISTICS: ($T_A=25^\circ\text{C}$ unless otherwise noted)

SYMBOL	TEST CONDITIONS	MIN	MAX	UNITS
I_{CBO}	$V_{CB}=50\text{V}$		10	nA
I_{CBO}	$V_{CB}=50\text{V}, T_A=125^\circ\text{C}$		10	μA
I_{CEV}	$V_{CE}=30\text{V}, V_{EB}=0.5\text{V}$		50	nA
BV_{CBO}	$I_C=10\mu\text{A}$	60		V
BV_{CEO}	$I_C=10\text{mA}$	60		V
BV_{EBO}	$I_E=10\mu\text{A}$	5.0		V
$V_{CE(SAT)}$	$I_C=150\text{mA}, I_B=15\text{mA}$		0.4	V
$V_{CE(SAT)}$	$I_C=500\text{mA}, I_B=50\text{mA}$		1.6	V
$V_{BE(SAT)}$	$I_C=150\text{mA}, I_B=15\text{mA}$		1.3	V
$V_{BE(SAT)}$	$I_C=500\text{mA}, I_B=50\text{mA}$		2.6	V
h_{FE}	$V_{CE}=10\text{V}, I_C=0.1\text{mA}$	75		
h_{FE}	$V_{CE}=10\text{V}, I_C=1.0\text{mA}$	100		
h_{FE}	$V_{CE}=10\text{V}, I_C=10\text{mA}$	100		
h_{FE}	$V_{CE}=10\text{V}, I_C=150\text{mA}$	100	300	
h_{FE}	$V_{CE}=10\text{V}, I_C=500\text{mA}$	50		
f_T	$V_{CE}=20\text{V}, I_C=50\text{mA}, f=100\text{MHz}$	200		MHz
C_{ob}	$V_{CB}=10\text{V}, I_E=0, f=1.0\text{MHz}$		8.0	pF
C_{ib}	$V_{BE}=2.0\text{V}, I_C=0, f=1.0\text{MHz}$		30	pF

R5 (1-February 2010)

CMPT2907A
SURFACE MOUNT
PNP SILICON TRANSISTOR



ELECTRICAL CHARACTERISTICS - Continued: ($T_A=25^\circ\text{C}$ unless otherwise noted)

SYMBOL	TEST CONDITIONS	MAX	UNITS
t_{on}	$V_{CC}=30\text{V}$, $V_{BE}=0.5\text{V}$, $I_C=150\text{mA}$, $I_{B1}=15\text{mA}$	45	ns
t_d	$V_{CC}=30\text{V}$, $V_{BE}=0.5\text{V}$, $I_C=150\text{mA}$, $I_{B1}=15\text{mA}$	10	ns
t_r	$V_{CC}=30\text{V}$, $V_{BE}=0.5\text{V}$, $I_C=150\text{mA}$, $I_{B1}=15\text{mA}$	40	ns
t_{off}	$V_{CC}=6.0\text{V}$, $I_C=150\text{mA}$, $I_{B1}=I_{B2}=15\text{mA}$	100	ns
t_s	$V_{CC}=6.0\text{V}$, $I_C=150\text{mA}$, $I_{B1}=I_{B2}=15\text{mA}$	80	ns
t_f	$V_{CC}=6.0\text{V}$, $I_C=150\text{mA}$, $I_{B1}=I_{B2}=15\text{mA}$	30	ns

SOT-23 CASE - MECHANICAL OUTLINE

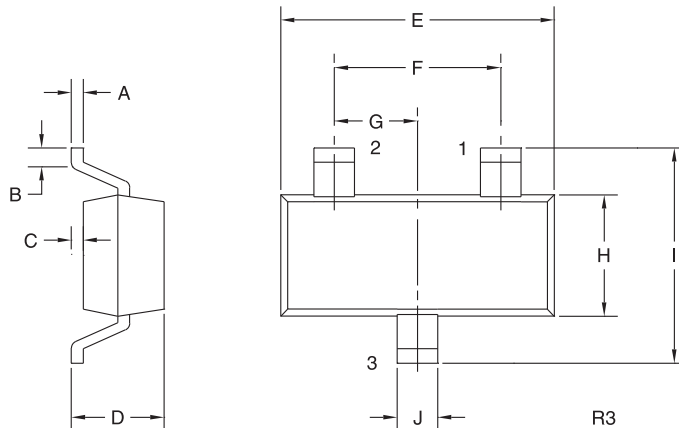

LEAD CODE:

- 1) Base
- 2) Emitter
- 3) Collector

MARKING CODE: C2F

SYMBOL	DIMENSIONS			
	INCHES		MILLIMETERS	
	MIN	MAX	MIN	MAX
A	0.003	0.007	0.08	0.18
B	0.006	-	0.15	-
C	-	0.005	-	0.13
D	0.035	0.043	0.89	1.09
E	0.110	0.120	2.80	3.05
F	0.075		1.90	
G	0.037		0.95	
H	0.047	0.055	1.19	1.40
I	0.083	0.098	2.10	2.49
J	0.014	0.020	0.35	0.50

SOT-23 (REV: R3)

R5 (1-February 2010)