

# UG10FCT AND UG10GCT

## ULTRAFAST SOFT RECOVERY RECTIFIER

Reverse Voltage - 400 Volts

Forward Current - 10.0 Amperes

### TO-220AB

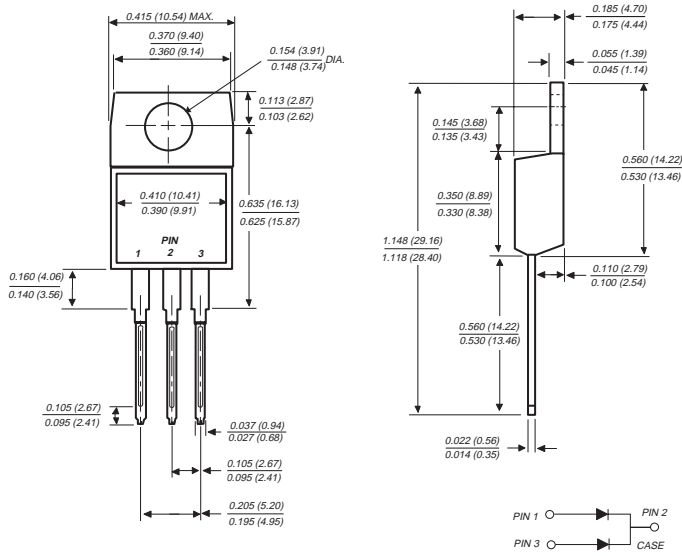

Dimensions in inches and (millimeters)

### FEATURES

- ◆ Plastic package has Underwriters Laboratories Flammability Classification 94V-0
- ◆ Ideally suited for free wheeling diode power factor correction applications
- ◆ Soft recovery characteristics
- ◆ Excellent high temperature switching
- ◆ Optimized to reduce switching losses
- ◆ High temperature soldering guaranteed: 250°C/10 seconds at terminals
- ◆ Glass passivated chip junction

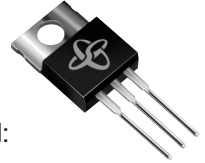

### MECHANICAL DATA

**Case:** JEDEC TO-220AB molded plastic body

**Terminals:** Plated leads, solderable per MIL-STD-750, Method 2026

**Polarity:** As marked

**Mounting Position:** Any

**Mounting Torque:** 5 in. - lbs. max.

**Weight:** 0.08 ounce, 2.24 grams

### MAXIMUM RATINGS AND ELECTRICAL CHARACTERISTICS

Ratings at 25°C ambient temperature unless otherwise specified.

	SYMBOLS	UG10FCT	UG10GCT	UNITS
Maximum repetitive peak reverse voltage	V <sub>RRM</sub>	300	400	Volts
Working peak reverse voltage	V <sub>RWM</sub>	225	300	Volts
Maximum RMS voltage	V <sub>RMS</sub>	210	280	Volts
Maximum DC blocking voltage	V <sub>DC</sub>	300	400	Volts
Maximum average forward rectified current at T <sub>C</sub> =100°C	I <sub>(AV)</sub>	10		Amps
Peak forward surge current 8.3ms single half sine-wave superimposed on rated load (JEDEC Method) per leg	I <sub>FSM</sub>	60A		Amps
Maximum instantaneous forward voltage per leg (NOTE 1) I <sub>F</sub> = 5A	V <sub>F</sub>	T <sub>J</sub> =25°C 1.30 T <sub>J</sub> =150°C 1.05		Volts
Maximum reverse leakage current at working peak reverse voltage	I <sub>R</sub>	T <sub>J</sub> =25°C 10 T <sub>J</sub> =100°C 200		µA
Maximum reverse recovery time per leg at I <sub>F</sub> =0.5A, I <sub>R</sub> =1.0A, I <sub>rr</sub> =0.25A	t <sub>rr</sub>	35		ns
Maximum Reverse recovery time per leg at I <sub>F</sub> =1.0A, di/dt=100A/µs, V <sub>R</sub> =30V, I <sub>rr</sub> =0.1 I <sub>RM</sub>	t <sub>rr</sub>	50		ns
Maximum reverse recovery current per leg at I <sub>F</sub> =5A, di/dt=50A/µs, V <sub>R</sub> =30V	I <sub>RM</sub>	3.0		Amps
Maximum stored charge per leg I <sub>F</sub> =2A, di/dt=20A/µs, V <sub>R</sub> =30V, I <sub>rr</sub> =0.1 I <sub>RM</sub>	Q <sub>rr</sub>	50		nC
Typical thermal resistance from junction to case per leg	R <sub>θJC</sub>	4.5		°C/W
Operating junction and storage temperature range	T <sub>J</sub> , T <sub>STG</sub>	-40 to +150		°C

**NOTE:** (1) Pulse test: 300µs pulse width, 1% duty cycle

**NOTICE:** Advanced product information is subject to change without notice

# RATINGS AND CHARACTERISTIC CURVES UG10FCT AND UG10GCT

