

BIDIRECTIONAL THYRISTOR SURGE SUPPRESSOR

APPLICATIONS

- T1/E1 Trunk & Line Card
- SLIC Line Card
- PBX Branch Exchange Switches
- FCC Part 68 Customer Premise Equipment
- Line Interface Modem
- ADSL Architecture Interface
- ISDN Architecture Interface

FEATURES

- Meets IEC 61000-4-4 & -5 Industry Requirements
- Provides Protection in Accordance with FCC Part 68, UL 1459, Bellcore 1089, ITU-TK.20 & K.21
- Peak Off-State Voltage from 120 to 275 Volts
- Surge Current Capability (See Surge Ratings Table)
- ESD Protection > 40 kilovolts
- Low Capacitance for T1/E1 Trunk & Line Card Applications
- UL 94V-0 Flammability Classification

MAXIMUM RATINGS

- Surge Current: 60A Max. (50/60 Hz) (I_{TSM})
- Storage Temperatures: -55° to + 150°C
- Junction Temperatures: T_j = -40° to 150°C
- Thermal Resistance for PPxxxxSB or SC in a DO-214AA Package is $R_{\theta JC} = 26^\circ\text{C/Watt}$ & $R_{\theta Jc} = 85^\circ\text{C/Watt}$
- Critical Rate of Rise of Maximum On-State Current: $di/dt = 500\text{A}/\mu\text{s}$
- Critical Rate of Rise of Maximum Off-State Voltage: $dv/dt > 2\text{kv}/\mu\text{s}$

MECHANICAL CHARACTERISTICS

- Package: Molded DO-214AA (JEDEC)
- Approximate Weight: 2.5 grams
- Body Marked with Logo and Marking Code

SURGE RATINGS						
SERIES	I_{PP} 2 X 10 μs AMPS	I_{PP} 10 X 160 μs AMPS	I_{PP} 10 X 560 μs AMPS	I_{PP} 10 X 1000 μs AMPS	I_{TSM} 60 Hz AMPS	di/dt AMPS/ μs
SB	300	150	100	75	30	500
SC	500	200	200	100	60	500

IEC 1000-4 COMPATIBLE



DO-214AA PACKAGE

DESCRIPTION

Defined product set SB and SC families are a series of Thyristor surge suppression (TSS) devices designed to protect telecommunication equipment against lightning. These devices can be used on central office equipment, PBX, DSU, OCU, digital telephones, fax machines, modems and radio controlled equipment. The bidirectional configuration provides protection for both positive and negative transients and the discrete surface mount package allows individual placement of the device on line cards or other locations where multiple component devices do not offer the versatile in board trace layout.

The ProTek TSS device can be used to provide protection in accordance with industry standard requirements, such as FCC Part 68, ANSI C62.41, UL 1459 and GR-1089-CORE. Their low capacitance is ideal for T1/E1 trunk or line card applications.

**DEVICE SYMBOL
(BIDIRECTIONAL)**

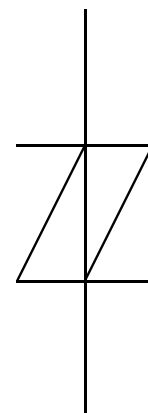

ELECTRICAL CHARACTERISTICS @ 25°C Ambient Temperature

PROTEK PART NUMBER	DEVICE MARKING CODE	REPETITIVE PEAK OFF-STATE VOLTAGE V_{DRM} VOLTS	SWITCHING VOLTAGE @ 100V/ μ s V_S VOLTS	MINIMUM HOLDING CURRENT (Figure 4) $di/dt = 1A/ms$ I_H mA	SWITCHING CURRENT I_S mA	MAXIMUM OFF-STATE CURRENT (Figure 2) @ V_{DRM} I_{DRM} μ A	MAXIMUM ON-STATE VOLTAGE (Figure 3) @ I_T V_T VOLTS	ON-STATE CURRENT I_T A	TYPICAL CAPACITANCE (See Note 1) @ 2V, 1 MHz C pF
PP3100SB-1	GY1	275	350	70	800	5	5	1.0	30
PP1300SC-1	HG1	120	160	70	800	5	5	1.0	80
PP1500SC-1	HH1	140	220	70	800	5	5	1.0	80
PP2300SC-1	HJ1	160	220	70	800	5	5	1.0	60
PP3100SC-1	HL1	275	350	70	800	5	5	1.0	60

Note 1: Capacitance imbalance between positive and negative polarities is typically < 15pF.

DO-214AA PACKAGE DIMENSIONS

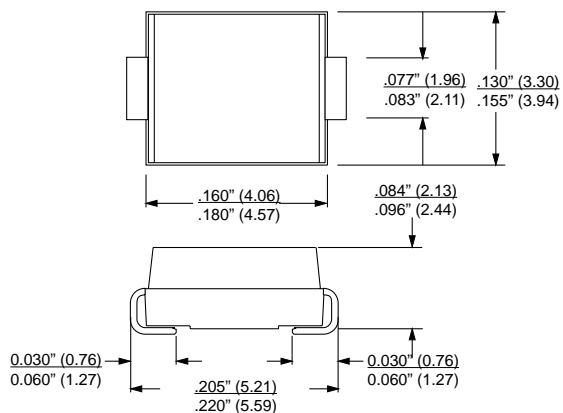

Measurements are in inches, (mm) denotes millimeters

FIGURE 1
PULSE WAVE FORM EXAMPLE

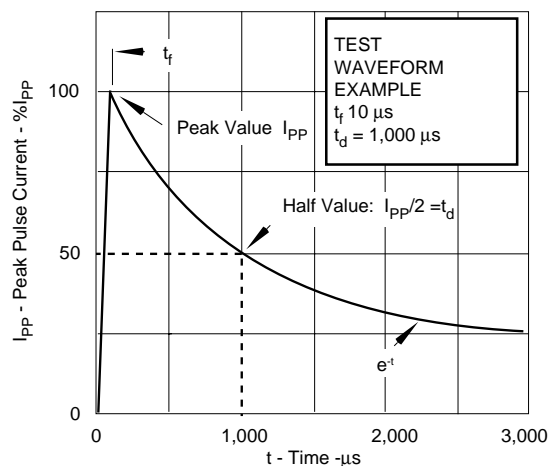

FIGURE 2
TYPICAL PEAK OFF-STATE CURRENT VS JUNCTION TEMPERATURE

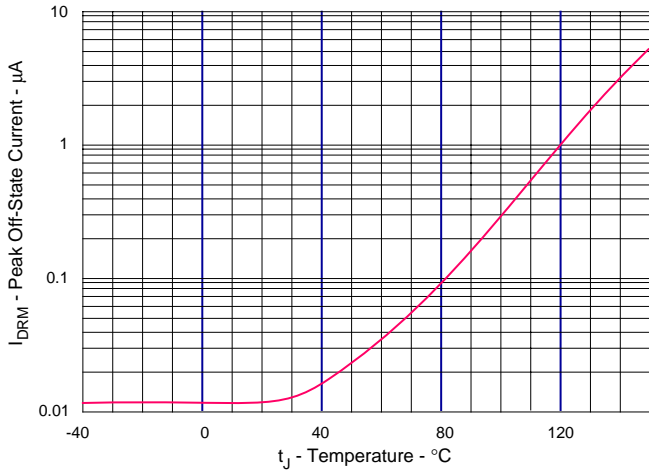

FIGURE 3
TYPICAL ON-STATE CURRENT VS ON-STATE VOLTAGE

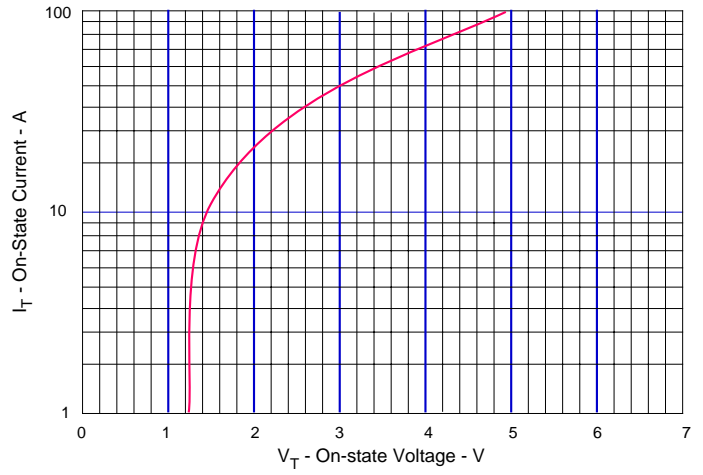

FIGURE 4
TYPICAL HOLDING CURRENT VS JUNCTION TEMPERATURE

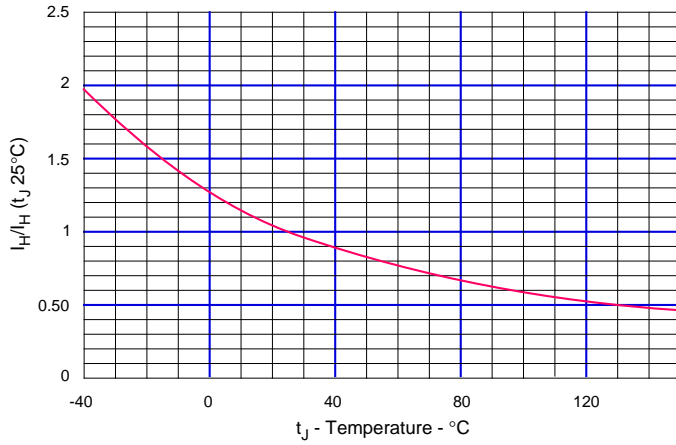

FIGURE 5
TYPICAL NORMALIZED V_S VS JUNCTION TEMPERATURE

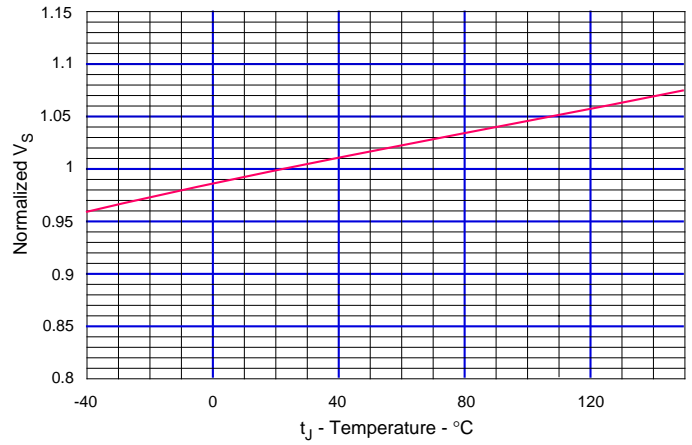

FIGURE 6
ON-STATE CURRENT VS SURGE CURRENT DURATION

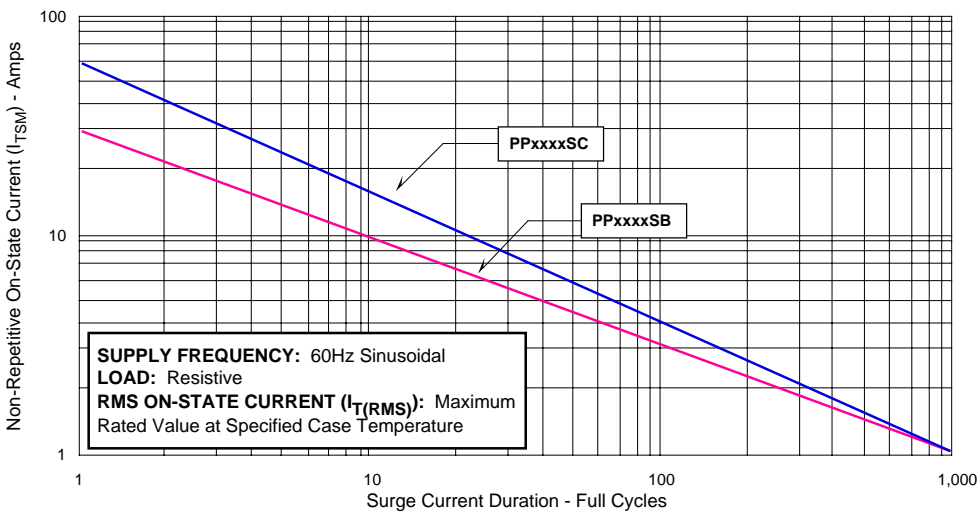
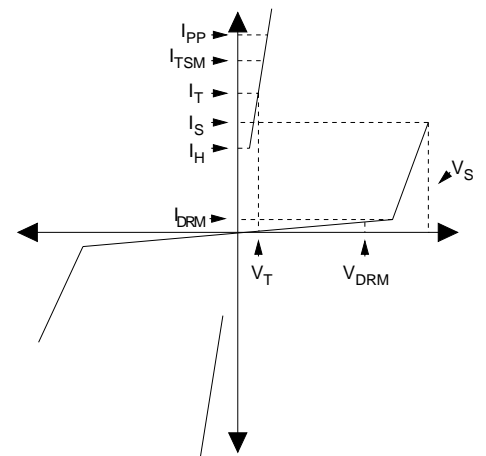
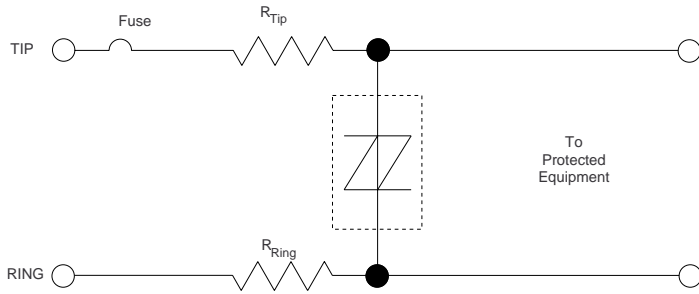

FIGURE 7
V- I CHARACTERISTICS CURVE



Application Notes for Thyristor Surge Suppressors used in Telecommunication Circuits

FIGURE 8 - UL 1459 & FCC Part 68 Metallic Protection



The TSS device is located across the tip-to-ring line after a limiting resistor and fuse combination. R_{TIP} and R_{RING} resistors are optional depending upon the TSS device selection. Without the resistors, the PP3100SB/SC is recommended. However, with a resistance value of 7.5 ohms for tip and ring, the PP3100SA is recommended. Digital signals may use a lower TSS device depending upon the total tip to ring voltage range. Selection of the TSS device, either PPxxxxSB or PPxxxxSC is based upon the value of the tip and ring resistors. For the National Electronic Code (NEC) article 800, it is recommended that at least one fuse be used in the tip or ring line for metallic surges. Fuses may be replaced with a suitable Positive Temperature Coefficient (PTC) automatic resettable current limiting device.

FIGURE 9 - UL 1459 & FCC Part 68 - Longitudinal Protection

There are two TSS devices, one located from tip-to-ground and one ring-to-ground. The PP3100SB/SC is recommended for resistor values of 7.5 ohms each. The National Electric Code (NEC) article 800 requires two fuse elements when connecting to ground. Fuses or a suitable Positive Temperature Coefficient (PTC) automatic resettable current limiting device may be used. The purpose of this circuit is to limit AC power current from getting on the ground line causing any safety hazard.

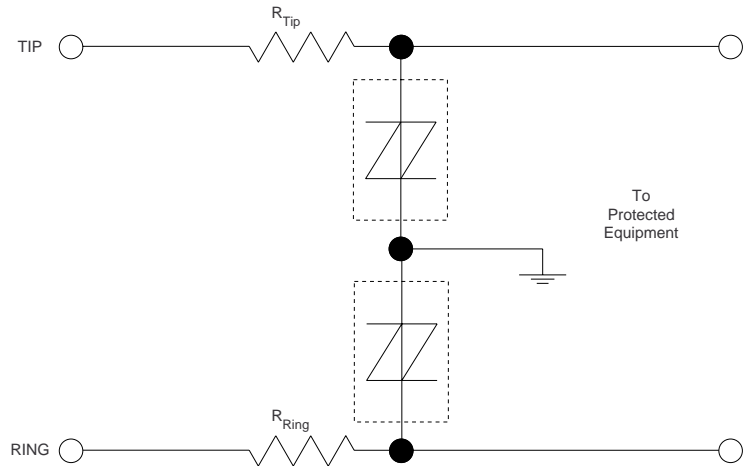
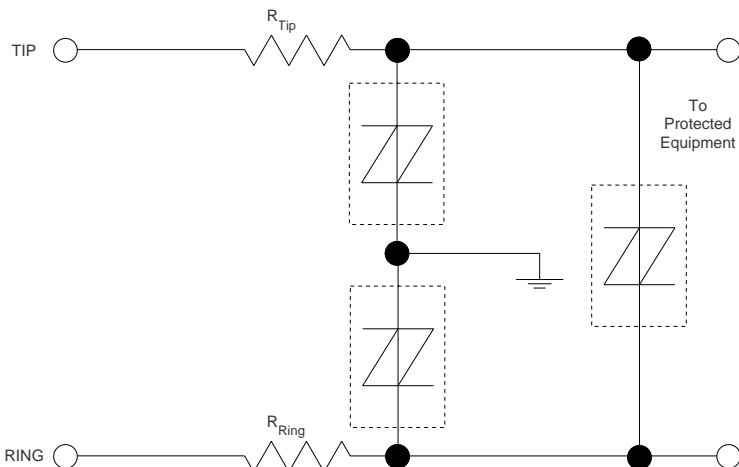

FIGURE 10 - UL 1459 & FCC Part 68 - Metallic and Longitudinal Protection



Three equal TSS devices are used in this application for metallic (tip-to-ring) and longitudinal (tip-to-ground and ring-to-ground) protection. For analog signals, the PP3100SB/SC is recommended. The National Electric Code (NEC) article 800 requires two fuse elements when connecting to ground. Fuses or a suitable Positive Temperature Coefficient (PTC) automatic resettable current limiting device may be used. This is circuit is recommended for protection against the Bellcore requirement: First Level Lightning Surge Tests (Telecommunications Port), document # GR-1089-CORE.

