



FSA2267 / FSA2267A

0.35Ω Low-Voltage Dual-SPDT Analog Switch

Features

- Typical 0.35Ω On Resistance (R_{ON}) for +2.7V supply
- FSA2267A features less than 10μA I_{CCT} current when S Input is lower than V_{CC}
- 0.25Ω maximum R_{ON} flatness for +2.7V supply
- 1.6mm x 2.1mm 10-Lead MicroPak™ package
- Broad V_{CC} operating range
- Low THD (0.02% typical for 32Ω load)
- High current handling capability (350mA continuous current under 3.3V supply)

Applications

- Cell phone
- PDA
- Portable media player

Description

The FSA2267 and FSA2267A are Dual Single Pole Double Throw (SPDT) analog switches. The FSA2267 operates from a single 1.65V to 3.6V supply, while the FSA2267A operates from a single 2.3V to 4.3V supply. Each features an ultra-low On Resistance of 0.35Ω at a +2.7V supply and 25°C. Both devices are fabricated with sub-micron CMOS technology to achieve fast switching speeds and designed for break-before-make operation.

FSA2267A features very low quiescent current, even when the control voltage is lower than the V_{CC} supply. This feature services the mobile handset applications very well, allowing for the direct interface with baseband processor general-purpose I/Os.

Ordering Information

Order Number	Top Mark	Lead-Free	Package Description	Packing Method
FSA2267L10X	FC	Yes	10-Lead MicroPak, 1.6 x 2.1mm, JEDEC MO-255	5000 Units on Tape and Reel
FSA2267MUX	FSA 2267	Yes	10-Lead Molded Small Outline Package (MSOP), JEDEC MO-187, 3.0mm Wide	3000 Units on Tape and Reel
FSA2267AL10X	FD	Yes	10-Lead MicroPak, 1.6 x 2.1mm, JEDEC MO-255	5000 Units on Tape and Reel
FSA2267AMUX	FSA 2267A	Yes	10-Lead Molded Small Outline Package (MSOP), JEDEC MO-187, 3.0mm Wide	4000 Units on Tape and Reel

Lead-Free package per JEDEC J-STD-020B.
MicroPak™ is a trademark of Fairchild Semiconductor Corporation.

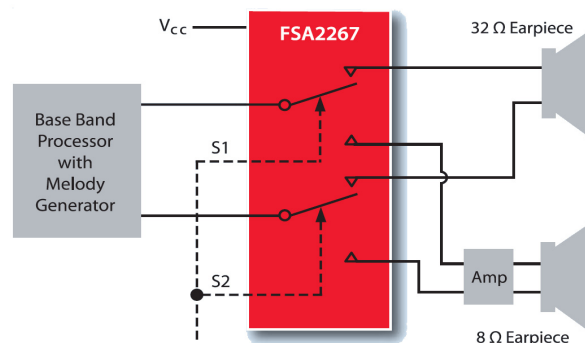

Figure 1. Application Diagram

Analog Symbols

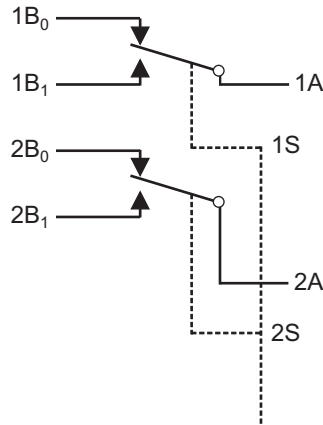

Figure 2. Analog Symbol

Connections Diagram

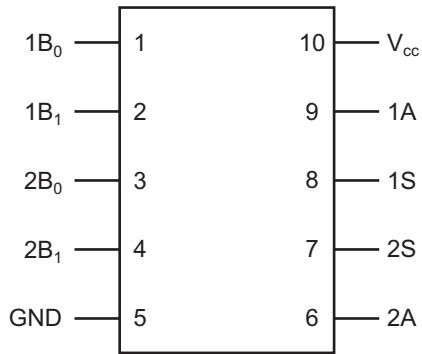

Figure 3. 10-Lead MSOP

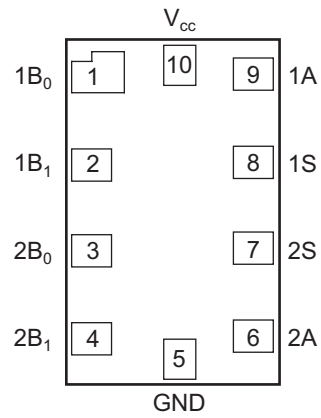

Figure 4. 10-Lead Micropak

Truth Table

Control Input(s)	Function
LOW Logic Level	B ₀ Connected to A
HIGH Logic Level	B ₁ Connected to A

Pin Descriptions

Pin Names	Function
1A, 2A, 1B ₀ , 1B ₁ , 2B ₀ , 2B ₁	Data Ports
1S, 2S	Control Input

Absolute Maximum Ratings

Stresses exceeding the absolute maximum ratings may damage the device. The device may not function or be operable above the recommended operating conditions and stressing the parts to these levels is not recommended. In addition, extended exposure to stresses above the recommended operating conditions may affect device reliability. The absolute maximum ratings are stress ratings only.

Symbol	Parameter	Min.	Max.	Unit
V_{CC}	Supply Voltage	-0.5	+5.5	V
V_S	Switch Voltage ⁽¹⁾	-0.5	$V_{CC} + 0.5$	V
V_{IN}	Input Voltage ⁽¹⁾	-0.5	V_{CC}	V
I_{IK}	Input Diode Current ⁽²⁾	-50		mA
I_{SW}	Switch Current		350	mA
I_{SWPEAK}	Peak Switch Current (Pulsed at 1ms duration, <10% Duty Cycle)		500	mA
T_{STG}	Storage Temperature Range	-65	+150	°C
T_J	Maximum Junction Temperature		+150	°C
T_L	Lead Temperature (Soldering, 10 seconds)		+260	°C
ESD	Human Body Model: FSA2267		7500	V
	Human Body Model: FSA2267A		7000	V
	Charged Device Model: FSA2267/FSA2267A		1000	V

Notes:

- The input and output negative voltage ratings may be exceeded if the input and output diode current ratings are observed.
- Minimums define the acceptable range of current. Negative current should not exceed minimum negative values.

Recommended Operating Conditions

The Recommended Operating Conditions table defines the conditions for actual device operation. Recommended operating conditions are specified to ensure optimal performance to the datasheet specifications. Fairchild does not recommend exceeding them or designing to absolute maximum ratings.

Symbol	Parameter	Min.	Max.	Unit
V_{CC}	Supply Voltage			V
	FSA2267	1.65	3.6	V
	FSA2267A	2.3	4.3	
V_{IN}	Control Input Voltage ⁽³⁾	0	V_{CC}	V
V_{SW}	Switch Input Voltage	0	V_{CC}	V
T_A	Operating Temperature	-40	+85	°C

Note:

- Unused inputs must be held HIGH or LOW. They may not float.

ESD Protection

ESD Performance of the FSA2267/FSA2267A

FSA2267

- HBM all pins 7.0kV
- CDM all pins 1.0kV

FSA267A

- HBM all pins 7.5kV
- CDM all pins 1.0kV

Human Body Model

Figure 5 shows the schematic representation of the Human Body Model ESD event. Figure 6 is the ideal waveform representation of the Human Body Model. The device is tested to JEDEC: JESD22-A114 Human Body Model.

Charged Device Model

In manufacturing test and handling environments, a more useful model is the Charged Device Model and the FSA2267/FSA2267A has a very good ESD immunity to this model. The device is tested to JEDEC: JESD22-C101 Charged Device Model.

IEC 61000-4-2

The IEC 61000-4-2 standard covers ESD testing and performance of finished equipment and evaluates the equipment in its entirety for ESD immunity. Fairchild Semiconductor has evaluated this device using the IEC 6100-4-2 representative system model depicted in Figure 7.

ESD values measured via the IEC 61000-4-2 evaluation method are influenced by the specific board layout, board size, and many other factors of the manufacturer's product application. Measured system ESD values cannot be guaranteed by Fairchild Semiconductor to exactly correlate to a manufacturer's in-house testing due to these application environment variables. Fairchild Semiconductor has been able to determine that, for ultra-portable applications, an enhanced ESD immunity, relative to the IEC 61000-4-2 specification, can be achieved with the inclusion of a 100Ω-series resistor in the V_{CC} supply path to the analog switch (see Figure 8). Typical improvements of between 3-6kV of ESD immunity (I/O to GND) have been measured with the inclusion of the resistor with the IEC 61000-4-2 representative model. For more information on ESD testing methodologies, please refer to:

AN-6019 Fairchild Analog Switch Products ESD Test Methodology Overview
<http://www.fairchildsemi.com/an/AN/AN-6019.pdf>

Additional ESD Test Conditions

For information regarding test methodologies and performance levels, please contact Fairchild Semiconductor.

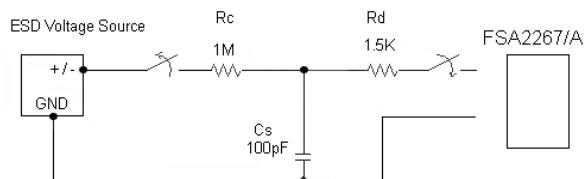

Figure 5. Human Body ESD Test Model

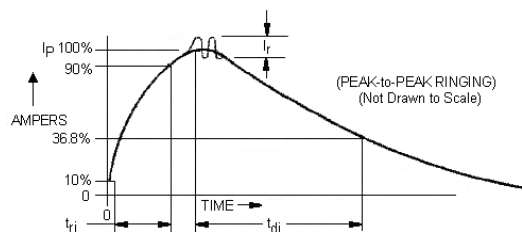

Figure 6. HBM Current Waveform

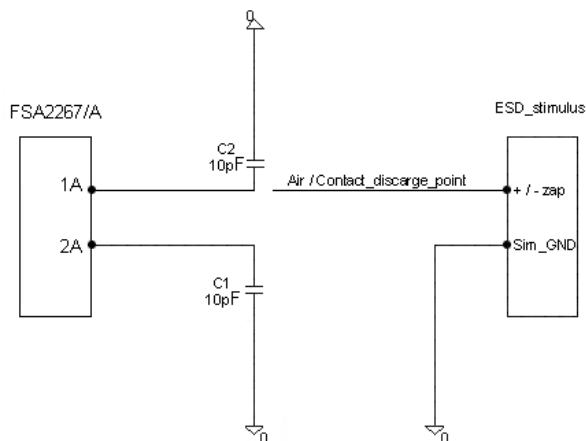

Figure 7. IEC 61000-4-2 ESD Test Model

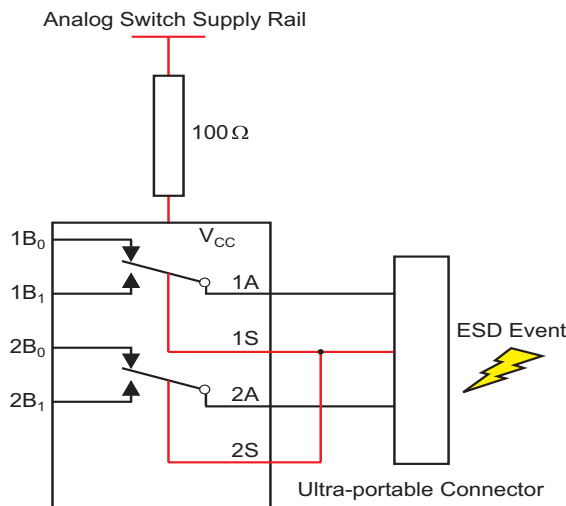

Figure 8. ESD Immunity with 100Ω Resistor

FSA2267 DC Electrical Characteristics

All typical values are at 25°C unless otherwise specified.

Symbol	Parameter	Conditions	V _{CC}	T _A = +25°C			T _A = -40 to +85°C		Units
			(V)	Min.	Typ.	Max.	Min.	Max.	
V _{IH}	Input Voltage High		2.7 to 3.6				2.0		V
			2.3 to 2.7				1.7		
			1.65 to 1.95				0.65 V _{CC}		
V _{IL}	Input Voltage Low		2.7 to 3.6					0.8	V
			2.3 to 2.7					0.7	
			1.65 to 1.95					0.35 V _{CC}	
I _{IN}	Control Input Leakage	V _{IN} = 0V to V _{CC}	1.65 to 3.6				-0.5	0.5	μA
I _{NO(OFF)} , I _{NC(OFF)}	Off-Leakage Current of Port nB ₀ and nB ₁	nA = 0.3V, 3.3V, nB ₀ or nB ₁ = 0.3V, 3.3V or floating	3.6	-5.0		5.0	-50	50	nA
		nA = 0.3V, 2.4V, nB ₀ or nB ₁ = 0.3V, 2.4V or floating	2.7	-5.0		5.0	-50	50	
		nA = 0.3V, 1.65V, nB ₀ or nB ₁ = 0.3V, 1.65V or floating	1.95	-5.0		5.0	-50	50	
I _{A(ON)}	On Leakage Current of Port 1A and 2A	nA = 0.3V, 3.3V, nB ₀ or nB ₁ = 0.3V, 3.3V or floating	3.6	-5.0		5.0	-50	50	nA
		nA = 0.3V, 2.4V, nB ₀ or nB ₁ = 0.3V, 2.4V or floating	2.7	-5.0		5.0	-50	50	
		nA = 0.3V, 1.65V, nB ₀ or nB ₁ = 0.3V, 1.65V or floating	1.95	-5.0		5.0	-50	50	
R _{ON}	Switch On Resistance ⁽⁴⁾ See Figure 9	I _{OUT} = 100mA, nB ₀ or nB ₁ = 0V, 0.7V, 2.0V, 2.7V	2.7		0.35			0.60	Ω
		I _{OUT} = 100mA, nB ₀ or nB ₁ = 0V, 0.7V, 1.6V, 2.3V	2.3		0.45			0.75	
		I _{OUT} = 100mA, nB ₀ or nB ₁ = 0.8V	1.65		1.0			3.9	
ΔR _{ON}	On Resistance Matching Between Channels ⁽⁵⁾	I _{OUT} = 100mA, nB ₀ or nB ₁ = 0.7V	2.7		0.040			0.075	Ω
			2.3		0.040			0.080	
			1.65		0.1				
R _{FLAT(ON)}	On Resistance Flatness ⁽⁶⁾	I _{OUT} = 100mA, nB ₀ or nB ₁ = 0V to V _{CC}	2.7					0.25	Ω
			2.3					0.3	
			1.65		0.3				
I _{CC}	Quiescent Supply Current	V _{IN} = 0V or V _{CC} , I _{OUT} = 0A	3.6	-100		100	-500	500	nA

Notes:

- On resistance is determined by the voltage drop between A and B pins at the indicated current through the switch.
- ΔR_{ON} = R_{ONmax} - R_{ONmin} measured at identical V_{CC}, temperature, and voltage.
- Flatness is defined as the difference between the maximum and minimum value of R_{ON} over the specified range of conditions.

FSA2267A DC Electrical Characteristics

All typical values are at 25°C unless otherwise specified.

Symbol	Parameter	Conditions	V _{CC}	T _A = +25°C			T _A = -40 to +85°C		Units
			(V)	Min.	Typ.	Max.	Min.	Max.	
V _{IH}	Input Voltage High		3.6 to 4.3				1.7		V
			2.7 to 3.6				1.5		
			2.3 to 2.7				1.4		
V _{IL}	Input Voltage Low		3.6 to 4.3					0.7	V
			2.7 to 3.6					0.5	
			2.3 to 2.7					0.4	
I _{IN}	Control Input Leakage	V _{IN} = 0V to V _{CC}	2.3 to 4.3				-0.5	0.5	μA
I _{NO(OFF)} , I _{NC(OFF)}	Off-Leakage Current of Port nB ₀ and nB ₁	nA = 0.3V, 4.0V, nB ₀ or nB ₁ = 4.0V, 0.3V or floating	4.3	-10.0		10.0	-100	100	nA
		nA = 0.3V, 3.3V, nB ₀ or nB ₁ = 0.3V, 3.3V or floating	3.6	-5.0		5.0	-50	50	
		nA = 0.3V, 2.4V, nB ₀ or nB ₁ = 0.3V, 2.4V or floating	2.7	-5.0		5.0	-50	50	
I _{A(ON)}	On Leakage Current of Port 1A and 2A	nA = 0.3V, 4.0V, nB ₀ or nB ₁ = 0.3V, 4.0V or floating	4.3	-20.0		20.0	-200	200	nA
		nA = 0.3V, 3.3V, nB ₀ or nB ₁ = 0.3V, 3.3V or floating	3.6	-5.0		5.0	-50	50	
		nA = 0.3V, 3.3V, nB ₀ or nB ₁ = 0.3V, 3.3V or floating	2.7	-5.0		5.0	-50	50	
R _{ON}	Switch On Resistance ⁽⁷⁾	I _{OUT} = 100mA, nB ₀ or nB ₁ = 0V, 0.7V, 3.6V, 4.3V	4.3		0.35			0.6	Ω
		I _{OUT} = 100mA, nB ₀ or nB ₁ = 0V, 0.7V, 2.3V, 3.0V	3.0		0.35			0.6	
		I _{OUT} = 100mA, nB ₀ or nB ₁ = 0V, 0.7V, 2.0V, 2.7V	2.7		0.35			0.6	
		I _{OUT} = 100mA, nB ₀ or nB ₁ = 0.8V	1.65		1.0				
ΔR _{ON}	On Resistance Matching Between Channels ⁽⁸⁾ See Figure 10	I _{OUT} = 100mA, nB ₀ or nB ₁ = 0.7V	4.3		0.04			0.075	Ω
			3.0		0.04			0.075	
			2.7		0.04			0.075	
			1.65		0.1				
R _{FLAT(ON)}	On Resistance Flatness ⁽⁹⁾	I _{OUT} = 100mA, nB ₀ or nB ₁ = 0V to V _{CC}	4.3		0.15			0.25	Ω
			3.0		0.15			0.25	
			2.7		0.15			0.25	
			1.65		0.3				
I _{CC}	Quiescent Supply Current	V _{IN} = 0V or V _{CC} , I _{OUT} = 0A	4.3	-100	80	100	-500	500	nA
I _{CCT}	Increase in I _{CC} per Input	V _{IN} = 1.8V	4.3		7.0	10.0		15.0	μA
		V _{IN} = 2.6V			0.5	2.0		7.0	

Notes:

7. On resistance is determined by the voltage drop between A and B pins at the indicated current through the switch.
8. ΔR_{ON} = R_{ONmax} - R_{ONmin} measured at identical V_{CC}, temperature, and voltage.
9. Flatness is defined as the difference between the maximum and minimum value of R_{ON} over the specified range of conditions.

FSA2267 AC Electrical Characteristics

All typical values are at 25°C unless otherwise specified.

Symbol	Parameter	Conditions	V _{CC} (V)	T _A = +25°C			T _A = -40 to +85°C		Units	Figure Number
				Min.	Typ.	Max.	Min.	Max.		
t _{ON}	Turn-On Time	nB ₀ or nB ₁ = 1.5V, R _L = 50Ω, C _L = 35 pF	2.7 to 3.6		30.0	38.0		42.0	ns	Figure 11
			2.3 to 2.7		29.0	37.0		40.0		
			1.65 to 1.95		27.0	35.0		38.0		
t _{OFF}	Turn-Off Time	nB ₀ or nB ₁ = 1.5V, R _L = 50Ω, C _L = 35 pF	2.7 to 3.6		13.0	16.0		18.0	ns	Figure 11
			2.3 to 2.7		14.0	18.0		20.0		
			1.65 to 1.95		15.0	21.0		25.0		
t _{BBM}	Break-Before-Make Time	nB ₀ or nB ₁ = 1.5V, R _L = 50Ω, C _L = 35 pF	2.7 to 3.6		17.0		2.0		ns	Figure 12
			2.3 to 2.7		15.0		2.0			
			1.65 to 1.95		12.0		2.0			
Q	Charge Injection	C _L = 100 pF, V _{GEN} = 0V, R _{GEN} = 0Ω	2.7 to 3.6		9.0				pC	Figure 14
		C _L = 100 pF, V _{GEN} = 0V, R _{GEN} = 0Ω	2.3 to 2.7		9.0					
		C _L = 100 pF, V _{GEN} = 0V, R _{GEN} = 0Ω	1.65 to 1.95		9.0					
OIRR	Off Isolation	f = 100kHz, R _L = 50Ω, C _L = 5pF (Stray)	2.7 to 3.6		-80.0				dB	Figure 13
			2.3 to 2.7		-80.0					
			1.65 to 1.95		-80.0					
Xtalk	Crosstalk	f = 100kHz, R _L = 50Ω, C _L = 5pF (Stray)	2.7 to 3.6		-80.0				dB	Figure 13
			2.3 to 2.7		-80.0					
			1.65 to 1.95		-80.0					
BW	-3db Bandwidth	R _L = 50Ω	1.65 to 3.6		45.0				MHz	Figure 16
THD	Total Harmonic Distortion	R _L = 32Ω, V _{IN} = 2V _{pk-pk} , f = 20Hz to 20kHz	2.7 to 3.6		0.024				%	Figure 17
		R _L = 32Ω, V _{IN} = 1.5V _{pk-pk} , f = 20Hz to 20kHz	2.3 to 2.7		0.015					
		R _L = 32Ω, V _{IN} = 1.2V _{pk-pk} , f = 20Hz to 20kHz	1.65 to 1.95		0.35					

FSA2267A AC Electrical Characteristics

All typical value are at 25°C unless otherwise specified.

Symbol	Parameter	Conditions	V _{CC} (V)	T _A = +25°C			T _A = -40 to +85°C		Units	Figure Number
				Min.	Typ.	Max.	Min.	Max.		
t _{ON}	Turn-On Time	nB ₀ or nB ₁ = 1.5V, R _L = 50Ω, C _L = 35pF	3.6 to 4.3		37.0	46.0		48.0	ns	Figure 11
			2.7 to 3.6		37.0	50.0		57.0		
			2.3 to 2.7		60					
			1.65		570					
t _{OFF}	Turn-Off Time	nB ₀ or nB ₁ = 1.5V, R _L = 50Ω, C _L = 35pF	3.6 to 4.3		15.0	23.0		25.0	ns	Figure 11
			2.7 to 3.6		16.0	30.0		30.0		
			2.3 to 2.7		50.0					
			1.65		500					
t _{B_{BM}}	Break-Before-Make Time	nB ₀ or nB ₁ = 1.5V, R _L = 50Ω, C _L = 35pF	3.6 to 4.3		8.0		2.0	ns	Figure 12	
			2.7 to 3.6		8.0		2.0			
			2.3 to 2.7		8.0		2.0			
Q	Charge Injection	C _L = 100 pF, V _{GEN} = 0V, R _{GEN} = 0Ω	3.6 to 4.3		24.0			pC	Figure 14	
		C _L = 100 pF, V _{GEN} = 0V, R _{GEN} = 0Ω	2.7 to 3.6		24.0					
		C _L = 100 pF, V _{GEN} = 0V, R _{GEN} = 0Ω	2.3 to 2.7		24.0					
OIRR	Off Isolation	f = 100kHz, R _L = 50Ω, C _L = 5pF (Stray)	3.6 to 4.3		-75.0			dB	Figure 13	
			2.7 to 3.6		-75.0					
			2.3 to 2.7		-75.0					
Xtalk	Crosstalk	f = 100kHz, R _L = 50Ω, C _L = 5pF (Stray)	3.6 to 4.3		-70.0			dB	Figure 13	
			2.7 to 3.6		-70.0					
			2.3 to 2.7		-70.0					
BW	-3db Bandwidth	R _L = 50Ω	2.3 to 4.3		45.0			MHz	Figure 16	
THD	Total Harmonic Distortion	R _L = 32Ω, V _{IN} = 2V _{pk-pk} , f = 20Hz to 20kHz	3.6 to 4.3		0.02			%	Figure 17	
		R _L = 32Ω, V _{IN} = 1.5V _{pk-pk} , f = 20Hz to 20kHz	2.7 to 3.6		0.02					
		R _L = 32Ω, V _{IN} = 1.2V _{pk-pk} , f = 20Hz to 20kHz	2.3 to 2.7		0.02					

Capacitance

Symbol	Parameter	Conditions	V _{CC} (V)	T _A = +25°C			T _A = -40 to +85°C		Units	Figure Number
				Min.	Typ.	Max.	Min.	Max.		
C _{IN}	Control Pin Input Capacitance	f = 1Mhz	0.0		1.5				pF	Figure 15
C _{OFF}	B Port Off Capacitance	f = 1Mhz	3.3		30.0				pF	Figure 15
C _{ON}	A Port On Capacitance	f = 1Mhz	3.3		126				pF	Figure 15

Typical Characteristics

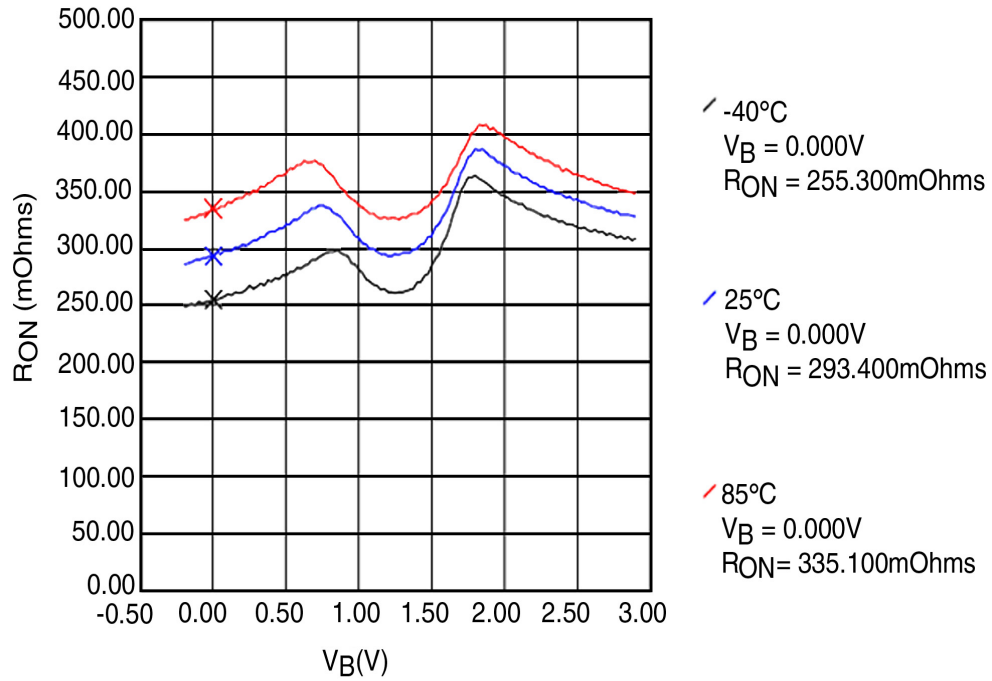

Figure 9. RON at 2.7V for FSA2267

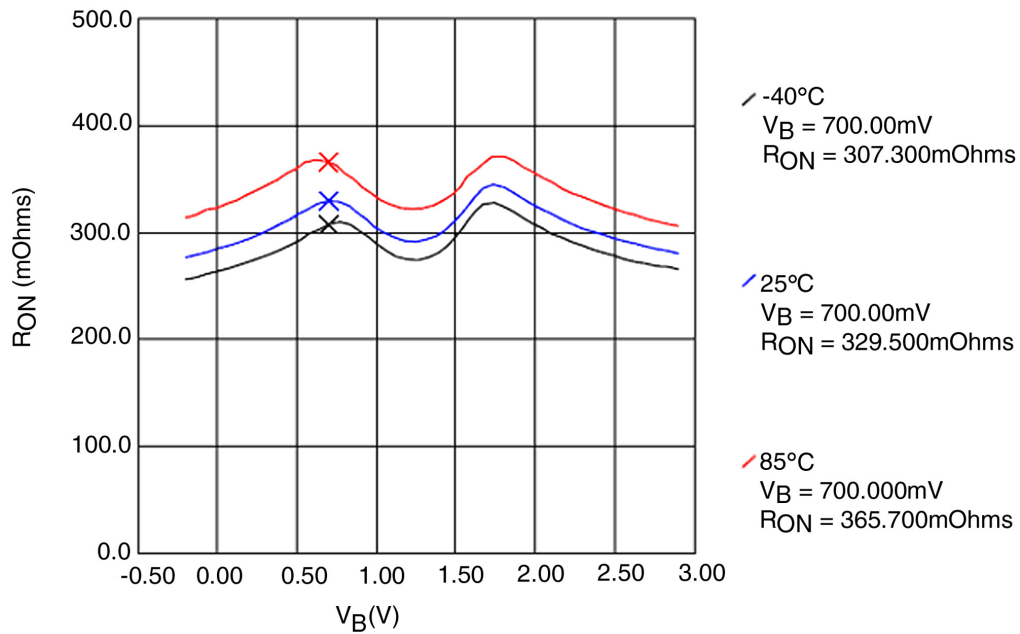
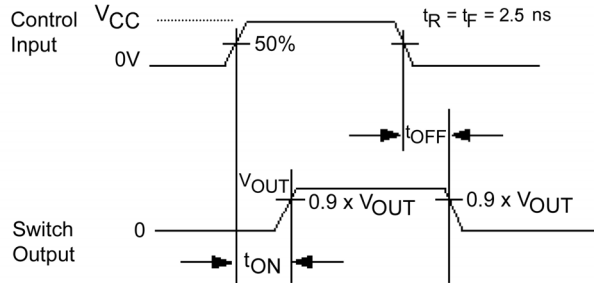
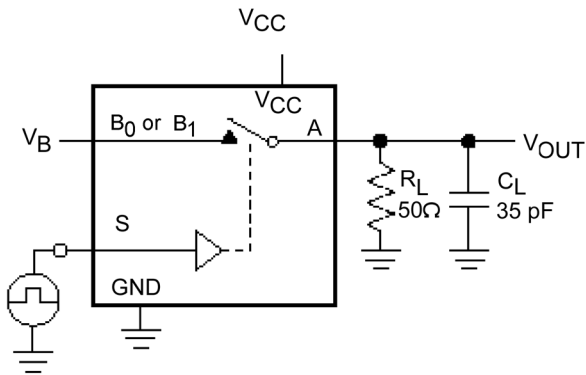

Figure 10. RON at 2.7V for FSA2267A

AC Loading and Waveforms



C_L includes Fixture and Stray Capacitance.

Logic input waveforms are inverted for switches with opposite logic sense.

Figure 11. Turn-On/Turn-Off Timing

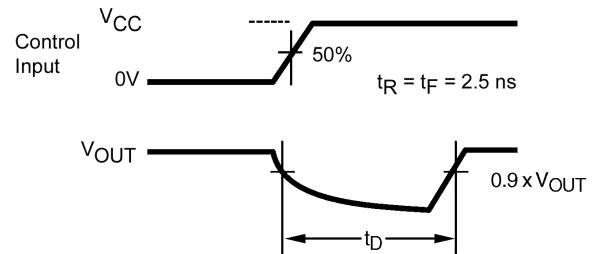
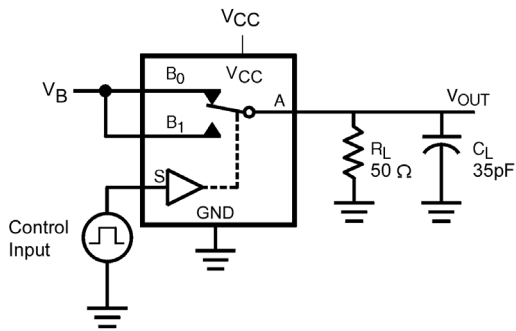

C_L Includes Fixture and Stray Capacitance

Figure 12. Break-Before-Make Timing

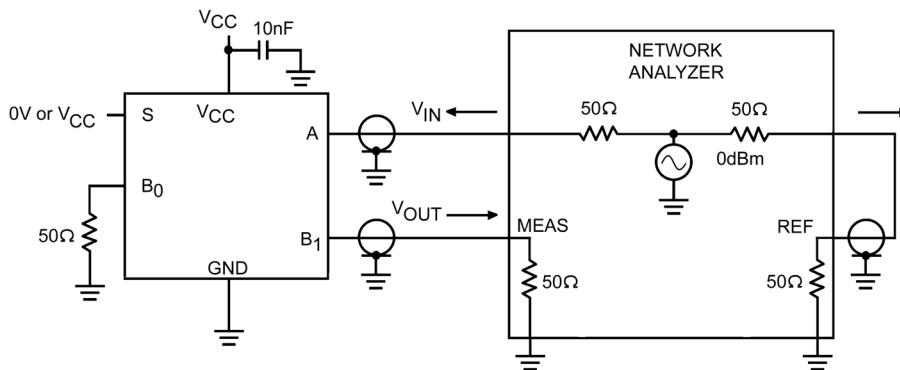

$$\text{OFF-ISOLATION} = 20 \log \frac{V_{\text{OUT}}}{V_{\text{IN}}}$$

$$\text{ON-LOSS} = 20 \log \frac{V_{\text{OUT}}}{V_{\text{IN}}}$$

$$\text{CROSSTALK} = 20 \log \frac{V_{\text{OUT}}}{V_{\text{IN}}}$$

Figure 13. Off Isolation and Crosstalk

AC Loading and Waveforms (Continued)

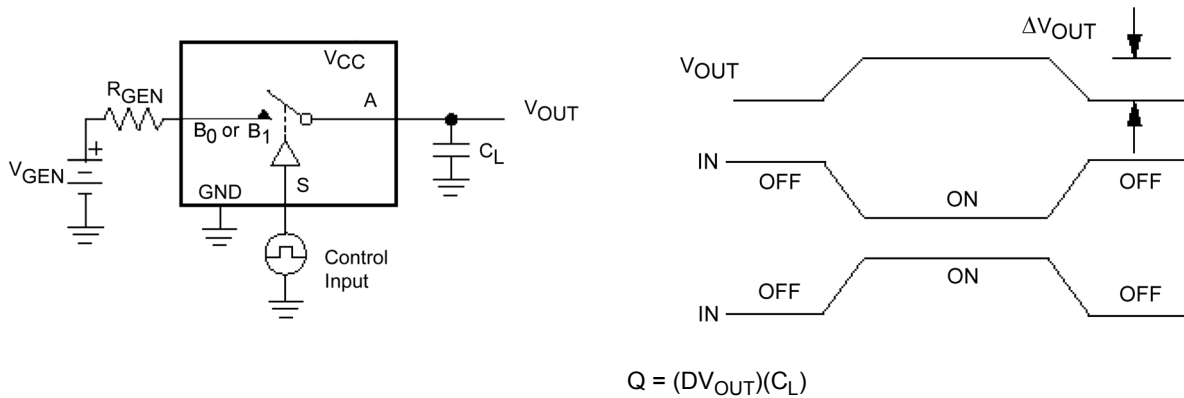

Figure 14. Charge Injection

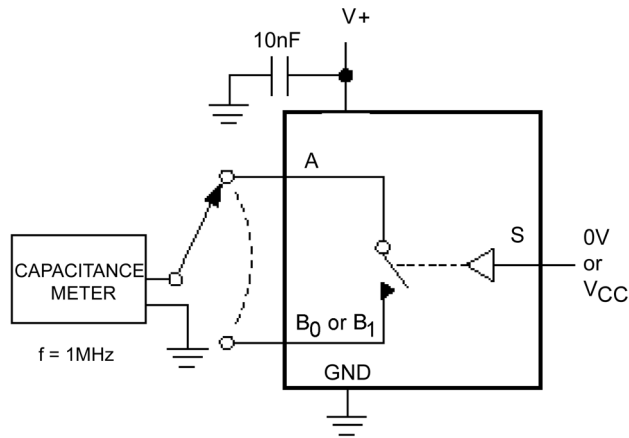

Figure 15. On/Off Capacitance Measurement Setup

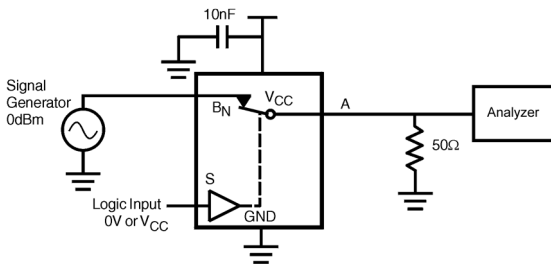

Figure 16. Bandwidth

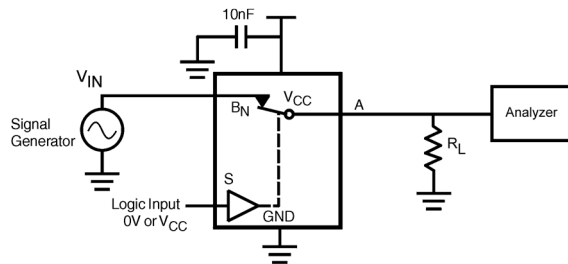

Figure 17. Harmonic Distortion

Tape and Reel Specification

Tape Format for MicroPak™ 10

Dimensions are in millimeters (inches) unless otherwise noted.

Package Designator	Tape Section	Cavity Number	Cavity Status	Cover Tape Status
L10X	Leader (Start End)	125 (typical)	Empty	Sealed
	Carrier	5000	Filled	Sealed
	Trailer (Hub End)	75 (typical)	Empty	Sealed

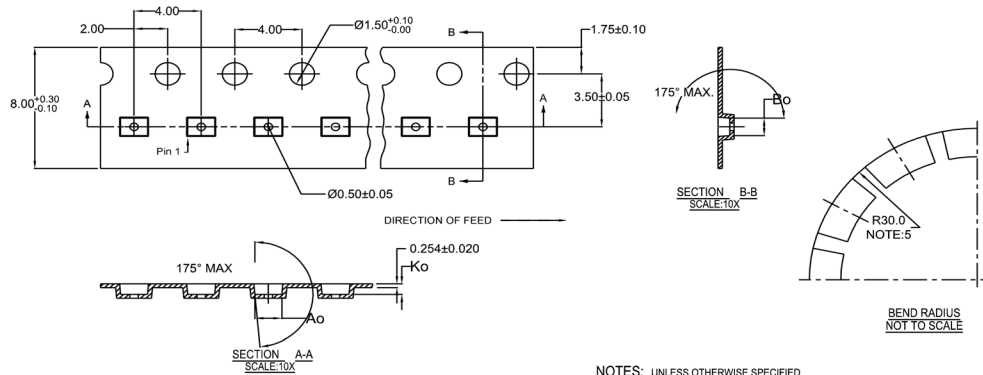

10	300056	2.30±0.05	1.78±0.05	0.68±0.05
8	300038	1.78±0.05	1.78±0.05	0.68±0.05
6	300033	1.60±0.05	1.15±0.05	0.70±0.05

NOTES: UNLESS OTHERWISE SPECIFIED

1. ACCUMULATED 50 SPROCKETS, SPROCKET HOLE PITCH IS 200.00 ±0.30MM
2. NO INDICATED CORNER RADIUS IS 0.127MM
3. CAMBER NOT TO EXCEED 1MM IN 100MM
4. SMALLEST ALLOWABLE BENDING RADIUS
5. POCKET POSITION RELATIVE TO SPROCKET HOLE MEASURED AS TRUE POSITION OF POCKET, NOT POCKET HOLE



SCALE: 6X

Reel Dimensions

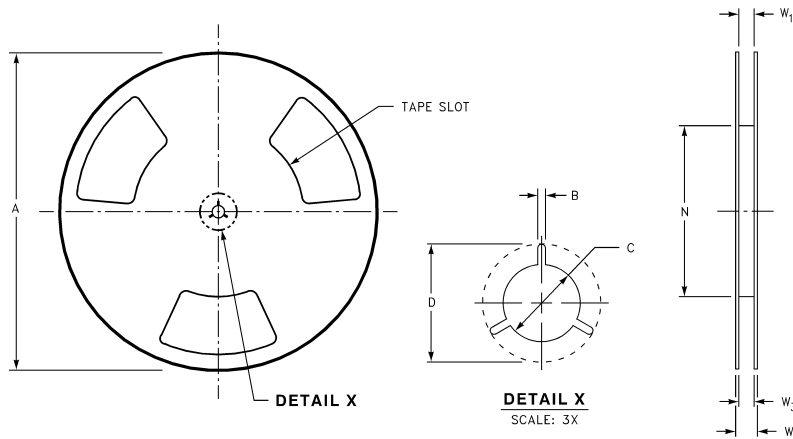

Tape Size	A	B	C	D	N	W1	W2	W3
	7.0	0.059	0.512	0.795	2.165	0.331 + 0.059/-0.000	0.567	W1 + 0.078/-0.039
(8mm)	(177.8)	(1.50)	(13.00)	(20.20)	(55.00)	(8.40 + 1.50/-0.00)	(14.40)	(W1 + 2.00/-1.00)

Physical Dimensions

Dimensions are in millimeters unless otherwise noted.

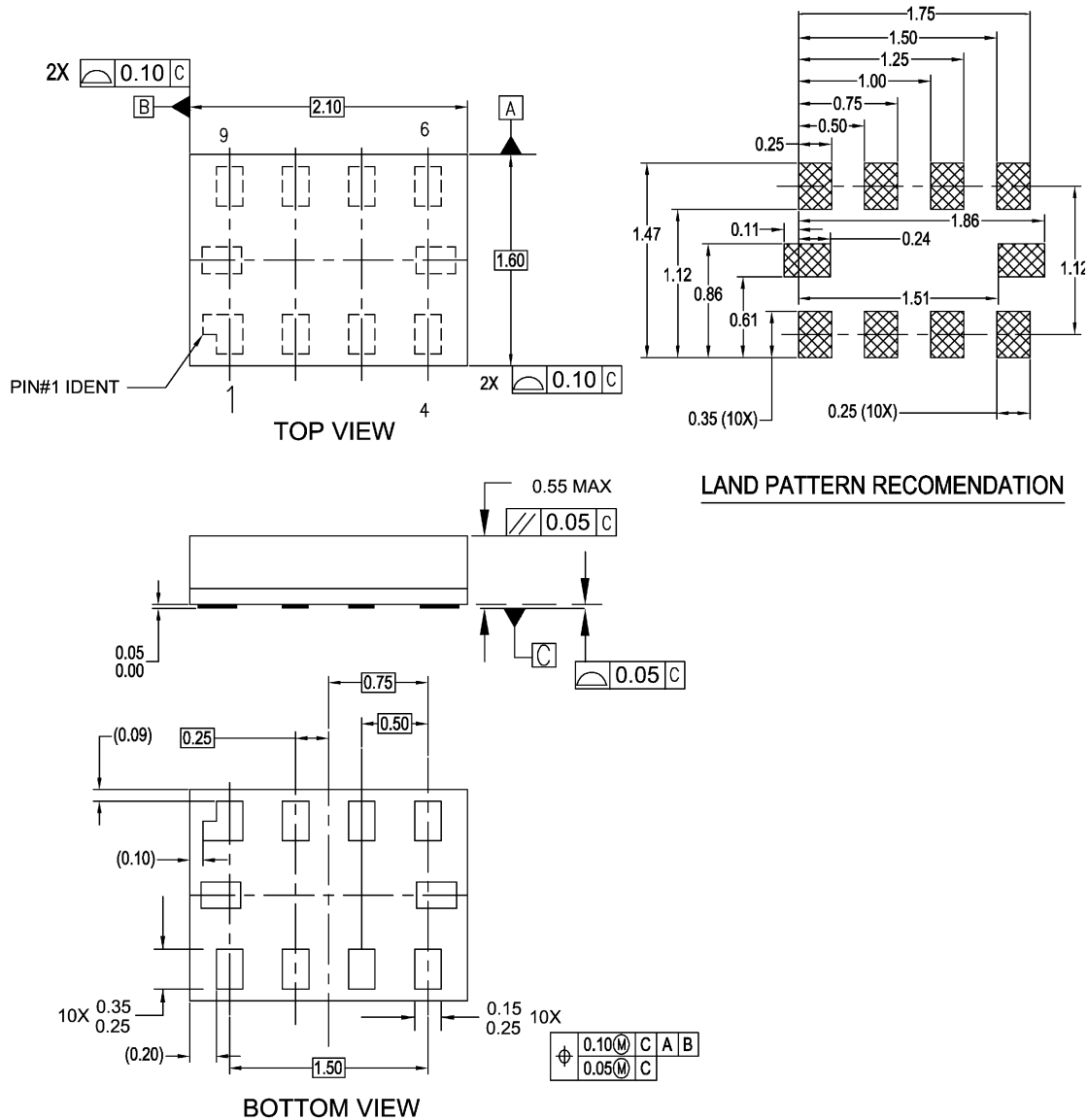

NOTES:

- A. PACKAGE CONFORMS TO JEDEC MO255, VARIATION UABD
- B. DIMENSIONS ARE IN MILLIMETERS.
- C. DIMENSIONS AND TOLERANCES CONFORMS TO ASME Y14.5M, 1994.

MAC010ARevC

Figure 18. Pb-Free, 10-Lead, MicroPak™, 1.6 x 2.1mm

Tape and Reel Specification

Tape Dimensions for MSOP 10

Dimensions are in millimeters unless otherwise specified.

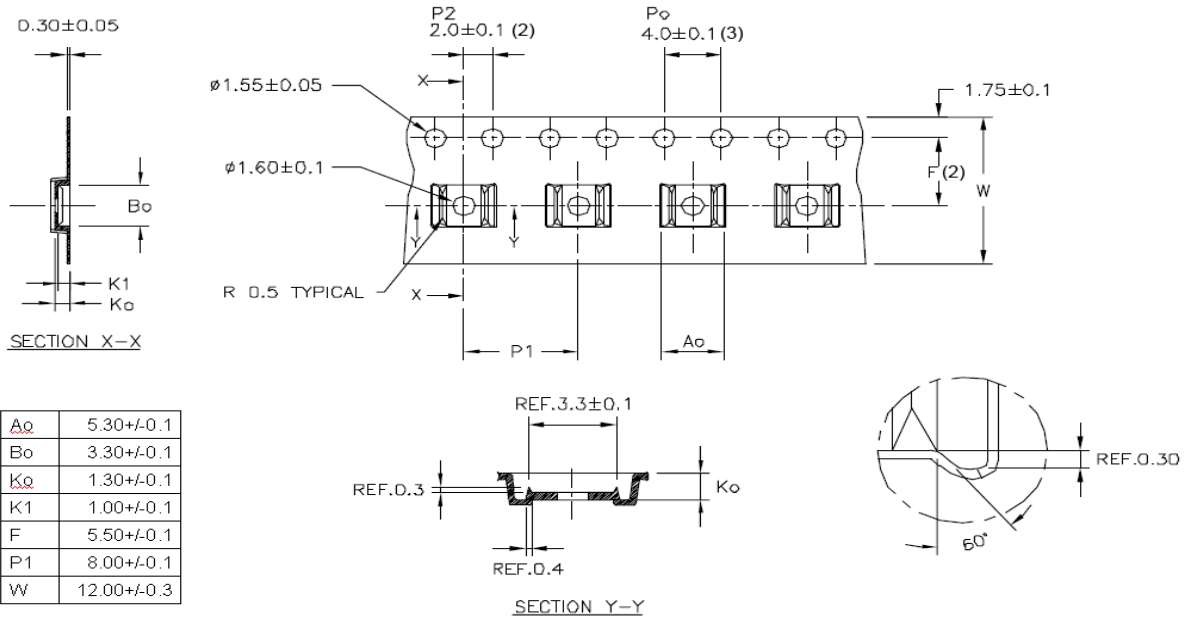

A ₀	5.30±0.1
B ₀	3.30±0.1
K ₀	1.30±0.1
K ₁	1.00±0.1
F	5.50±0.1
P ₁	8.00±0.1
W	12.00±0.3

Notes:

1. All dimensions are in millimeters.
2. Measured from centerline of sprocket hole to centerline of pocket.
3. Cumulative tolerance of ten sprocket holes is ±0.20mm.
4. Other material available.

Reel Dimensions for MSOP

Dimensions are in inches (millimeters) unless otherwise specified.

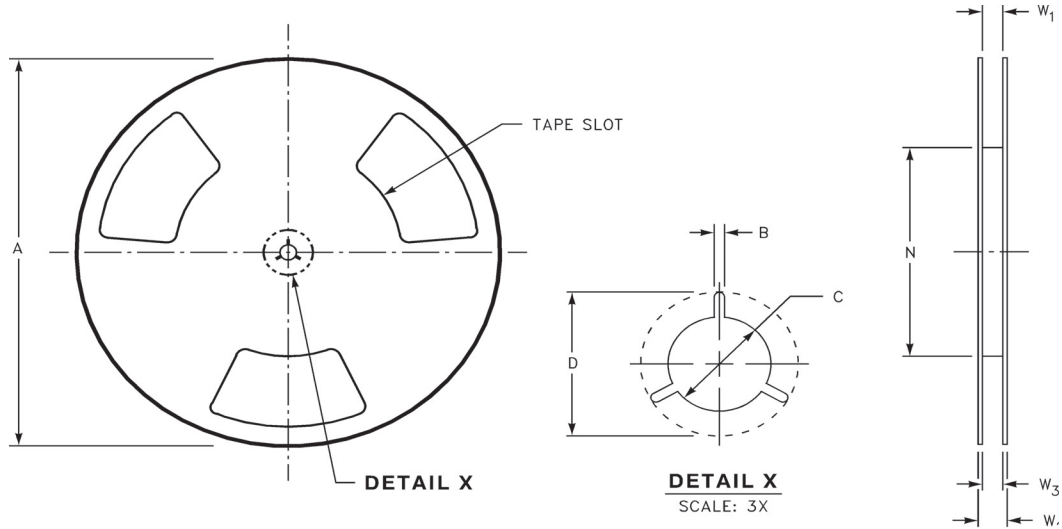

Tape Size	A	B	C	D	N	W1	W2	W3
	13	0.059	0.512	0.795	7.008	0.448	0.724	0.468-0.606
(12mm)	(330)	(1.5)	(13)	(20.2)	(178)	(12.4)	(18.4)	(11.9 -15.4)

Physical Dimensions

Dimensions are in millimeters unless otherwise noted.

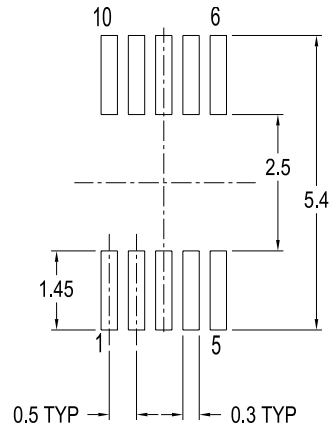
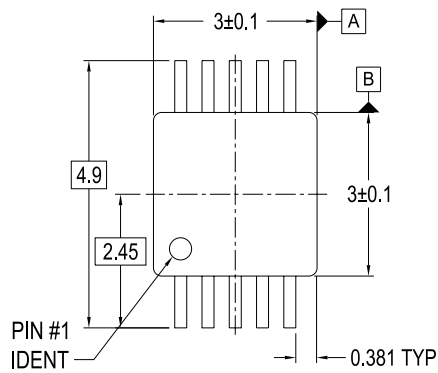

LAND PATTERN RECOMENDATION

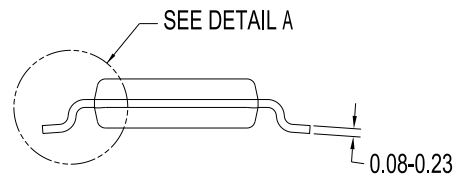
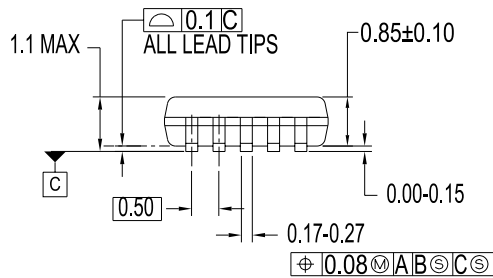

DIMENSIONS ARE IN MILLIMETERS

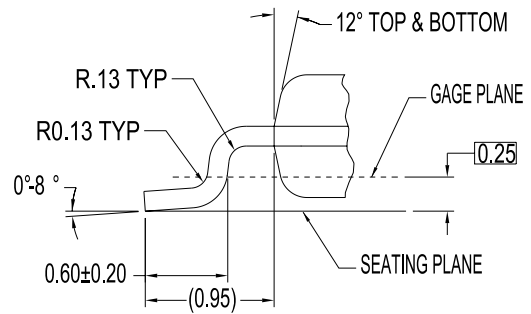

DETAIL A

NOTES:

- A. CONFORMS TO JEDEC REGISTRATION MO-187, VARIATION BA, REF NOTE 6, DATE 11/00.
- B. DIMENSIONS ARE IN MILLIMETERS.
- C. DIMENSIONS ARE EXCLUSIVE OF BURRS, MOLD FLASH, AND TIE BAR EXTRUSIONS.
- D. DIMENSIONS AND TOLERANCES PER ASME Y14.5M, 1994.

MUA10AREVA

Figure 19. Pb-Free, 10-Lead, Molded Small Outline Package (MSOP), JEDEC MO-187, 3.0mm Wide

TRADEMARKS

The following are registered and unregistered trademarks Fairchild Semiconductor owns or is authorized to use and is not intended to be an exhaustive list of all such trademarks.

ACEx [®]	HiSeC [™]	Programmable Active Droop [™]	TinyLogic [®]
Across the board. Around the world. [™]	i-Lo [™]	QFET [®]	TINYOPTO [™]
ActiveArray [™]	ImpliedDisconnect [™]	QST [™]	TinyPower [™]
Bottomless [™]	IntelliMAX [™]	QT Optoelectronics [™]	TinyWire [™]
Build it Now [™]	ISOPLANAR [™]	Quiet Series [™]	TruTranslation [™]
CoolFET [™]	MICROCOUPLER [™]	RapidConfigure [™]	μSerDes [™]
CROSSVOLT [™]	MicroPak [™]	RapidConnect [™]	UHC [®]
CTL [™]	MICROWIRE [™]	ScalarPump [™]	UniFET [™]
Current Transfer Logic [™]	MSX [™]	SMART START [™]	VCX [™]
DOMET [™]	MSXPro [™]	SPM [®]	Wire [™]
E ² CMOS [™]	OCX [™]	STEALTH [™]	
EcoSPARK [®]	OCXPro [™]	SuperFET [™]	
EnSigna [™]	OPTOLOGIC [®]	SuperSOT [™] -3	
FACT Quiet Series [™]	OPTOPLANAR [®]	SuperSOT [™] -6	
FACT [®]	PACMAN [™]	SuperSOT [™] -8	
FAST [®]	POP [™]	SyncFET [™]	
FASTr [™]	Power220 [®]	TCM [™]	
FPS [™]	Power247 [®]	The Power Franchise [®]	
FRFET [®]	PowerEdge [™]	 ™	
GlobalOptoisolator [™]	PowerSaver [™]	TinyBoost [™]	
GTO [™]	PowerTrench [®]	TinyBuck [™]	

DISCLAIMER

FAIRCHILD SEMICONDUCTOR RESERVES THE RIGHT TO MAKE CHANGES WITHOUT FURTHER NOTICE TO ANY PRODUCTS HEREIN TO IMPROVE RELIABILITY, FUNCTION OR DESIGN. FAIRCHILD DOES NOT ASSUME ANY LIABILITY ARISING OUT OF THE APPLICATION OR USE OF ANY PRODUCT OR CIRCUIT DESCRIBED HEREIN; NEITHER DOES IT CONVEY ANY LICENSE UNDER ITS PATENT RIGHTS, NOR THE RIGHTS OF OTHERS. THESE SPECIFICATIONS DO NOT EXPAND THE TERMS OF FAIRCHILD'S WORLDWIDE TERMS AND CONDITIONS, SPECIFICALLY THE WARRANTY THEREIN, WHICH COVERS THESE PRODUCTS.

LIFE SUPPORT POLICY

FAIRCHILD'S PRODUCTS ARE NOT AUTHORIZED FOR USE AS CRITICAL COMPONENTS IN LIFE SUPPORT DEVICES OR SYSTEMS WITHOUT THE EXPRESS WRITTEN APPROVAL OF FAIRCHILD SEMICONDUCTOR CORPORATION.

As used herein:

- Life support devices or systems are devices or systems which, (a) are intended for surgical implant into the body or (b) support or sustain life, and (c) whose failure to perform when properly used in accordance with instructions for use provided in the labeling, can be reasonably expected to result in a significant injury of the user.
- A critical component in any component of a life support, device, or system whose failure to perform can be reasonably expected to cause the failure of the life support device or system, or to affect its safety or effectiveness.

PRODUCT STATUS DEFINITIONS

Definition of Terms

Datasheet Identification	Product Status	Definition
Advance Information	Formative or In Design	This datasheet contains the design specifications for product development. Specifications may change in any manner without notice.
Preliminary	First Production	This datasheet contains preliminary data; supplementary data will be published at a later date. Fairchild Semiconductor reserves the right to make changes at any time without notice to improve design.
No Identification Needed	Full Production	This datasheet contains final specifications. Fairchild Semiconductor reserves the right to make changes at any time without notice to improve design.
Obsolete	Not In Production	This datasheet contains specifications on a product that has been discontinued by Fairchild Semiconductor. The datasheet is printed for reference information only.

Rev. 124