

## Features

- Attenuation: 2 dB steps to 30 dB
- Temperature Stability:  $\pm 0.18$  dB from  $-55^{\circ}\text{C}$  to  $+85^{\circ}\text{C}$  Typical
- Low DC Power Consumption
- Hermetic Surface Mount Package
- Fast Switching Speed, 12 ns Typical
- 50 Ohm Nominal Impedance

## Description

M/A-COM's AT-232 is a GaAs FET 4-bit digital attenuator with a 2 dB minimum step size and 30 dB total attenuation. This attenuator is in a hermetically sealed ceramic 16-lead surface mount package. The AT-232 is ideally suited for use where accuracy, fast switching, very low power consumption and low intermodulation products are required. Typical applications include dynamic range setting in precision receiver circuits and other gain/leveling control circuits. Environmental screening is available. Contact the factory for information.

## Electrical Specifications<sup>1</sup> (From $-55^{\circ}\text{C}$ to $+85^{\circ}\text{C}$ )

Parameter	Test Conditions	Frequency	Units	Min	Typ	Max
Reference Insertion Loss	—	DC - 0.5 GHz	dB	—	—	2.0
		DC - 1.0 GHz	dB	—	—	2.3
		DC - 2.0 GHz	dB	—	—	2.5
Attenuation Accuracy <sup>2</sup>	Any Single Bit	DC - 1.0 GHz DC - 2.0 GHz	$\pm (0.15 \text{ dB} + 3\% \text{ of atten setting in dB}) \text{ dB}$ $\pm (0.2 \text{ dB} + 3\% \text{ of atten setting in dB}) \text{ dB}$ Or $\pm 0.45 \text{ dB}$ , whichever is greater			
	Any Combination of Bits	DC - 1.0 GHz DC - 2.0 GHz	$\pm (0.22 \text{ dB} + 3\% \text{ of atten setting in dB}) \text{ dB}$ $\pm (0.25 \text{ dB} + 4\% \text{ of atten setting in dB}) \text{ dB}$ Or $\pm 0.45 \text{ dB}$ , whichever is greater			
VSWR	—	DC - 2.0 GHz	Ratio	—	—	1.6:1
Trise, Tfall	10% to 90%	—	ns	—	12	—
Ton, Toff	50% Control to 90/10% RF	—	ns	—	18	—
Transients	In-Band (peak-peak)	—	mV	—	25	—
1 dB Compression	Input Power Input Power	0.05 GHz	dBm	—	+20	—
		0.5 - 2.0 GHz	dBm	—	+28	—
Input IP3	For two-tone Input Power Up to +5 dBm	0.05 GHz	dBm	—	+40	—
		0.5 - 2.0 GHz	dBm	—	+50	—
Input IP2	For two-tone Input Power Up to +5 dBm	0.05 GHz	dBm	—	+45	—
		0.5 - 2.0 GHz	dBm	—	+68	—

1. All specifications apply when operated with control voltages of 0.0V to -5.0V.
2. This attenuator is guaranteed monotonic.

## CR-6

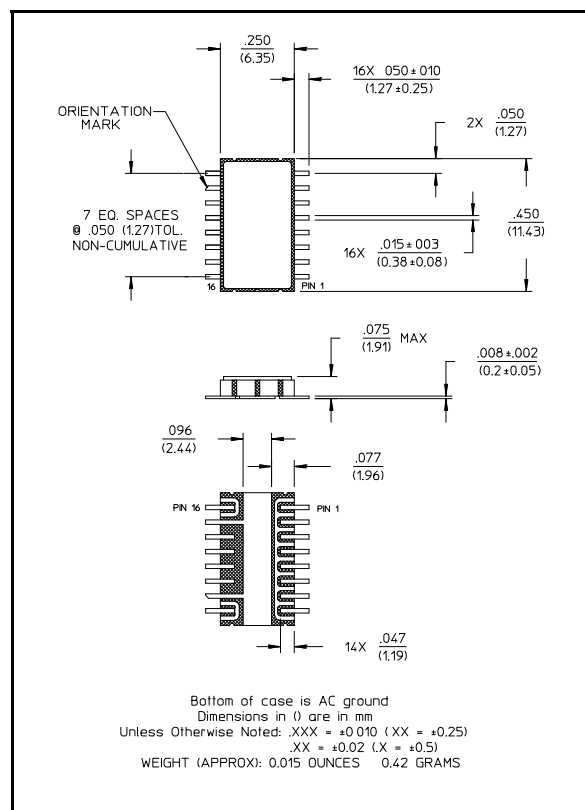

Electrical Specifications (From -55°C to +85°C)

Parameter	Test Conditions	Frequency	Units	Min	Typ	Max
Input Leakage Current (Low)	-0.2 to 0V	—	μA	—	—	20
Input Leakage Current (High)	-8.0 to -5.0V	—	μA	—	—	200

Absolute Maximum Ratings <sup>3</sup>

Parameter	Absolute Maximum
Max Input Power 0.05 GHz 0.5 - 2.0 GHz	+27 dBm +34 dBm
Control Voltage	+0.5V, -8.5V
Operating Temperature	-55°C to +125°C
Storage Temperature	-65°C to +150°C

3. Operation of this device above any one of these parameters may cause permanent damage.

Truth Table

Control Inputs								
/VC4	VC4	/VC3	VC3	/VC2	VC2	/VC1	VC1	Atten. (dB)
-5V	0V	-5V	0V	-5V	0V	-5V	0V	Ref.
0V	-5V	-5V	0V	-5V	0V	-5V	0V	2 dB
-5V	0V	0V	-5V	-5V	0V	-5V	0V	4 dB
-5V	0V	-5V	0V	0V	-5V	-5V	0V	8 dB
-5V	0V	-5V	0V	-5V	0V	0V	-5V	16 dB
0V	-5V	0V	-5V	0V	-5V	0V	-5V	30 dB

Functional Schematic (Top View)

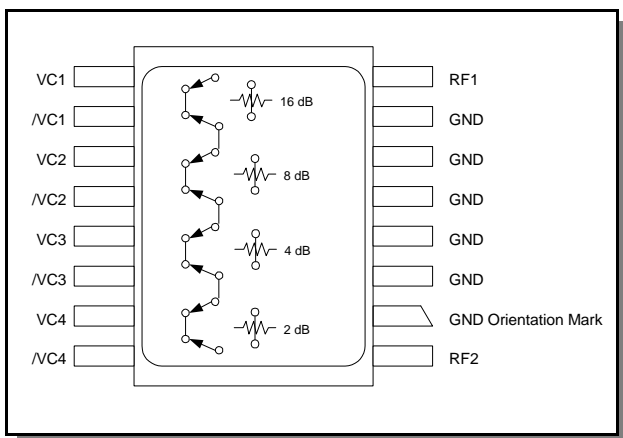

Specifications subject to change without notice.

- North America: Tel. (800) 366-2266
- Asia/Pacific: Tel.+81-44-844-8296, Fax +81-44-844-8298
- Europe: Tel. +44 (1344) 869 595, Fax+44 (1344) 300 020

Visit [www.macom.com](http://www.macom.com) for additional data sheets and product information.

Typical Performance Curves

Ref. Insertion Loss vs. Frequency

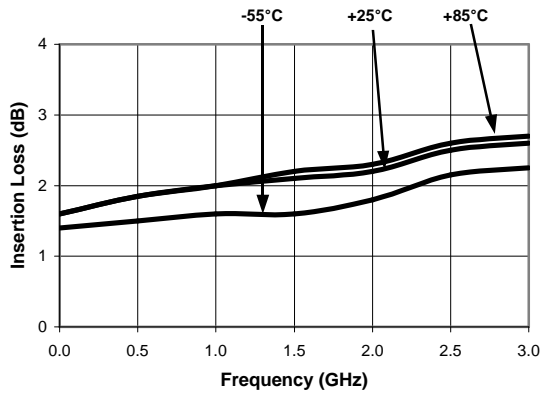

VSWR vs. Frequency

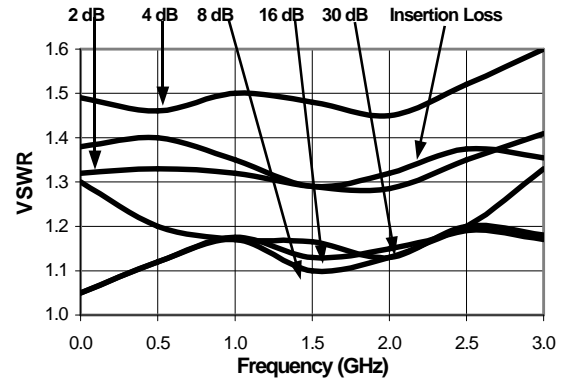

Attenuation Accuracy vs. Frequency

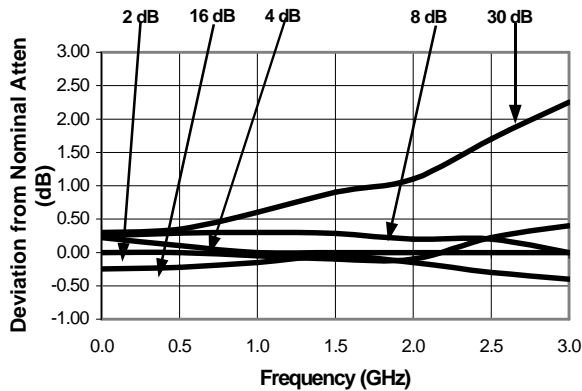

Ordering Information

Part Number	Package
AT-232 PIN	CR-6

Specifications subject to change without notice.

- North America: Tel. (800) 366-2266
- Asia/Pacific: Tel.+81-44-844-8296, Fax +81-44-844-8298
- Europe: Tel. +44 (1344) 869 595, Fax+44 (1344) 300 020

Visit [www.macom.com](http://www.macom.com) for additional data sheets and product information.

