

RECOMMENDED MOUNTING HOLE PATTERN FOR 1.60 [0.063] THICK P.C. BOARD

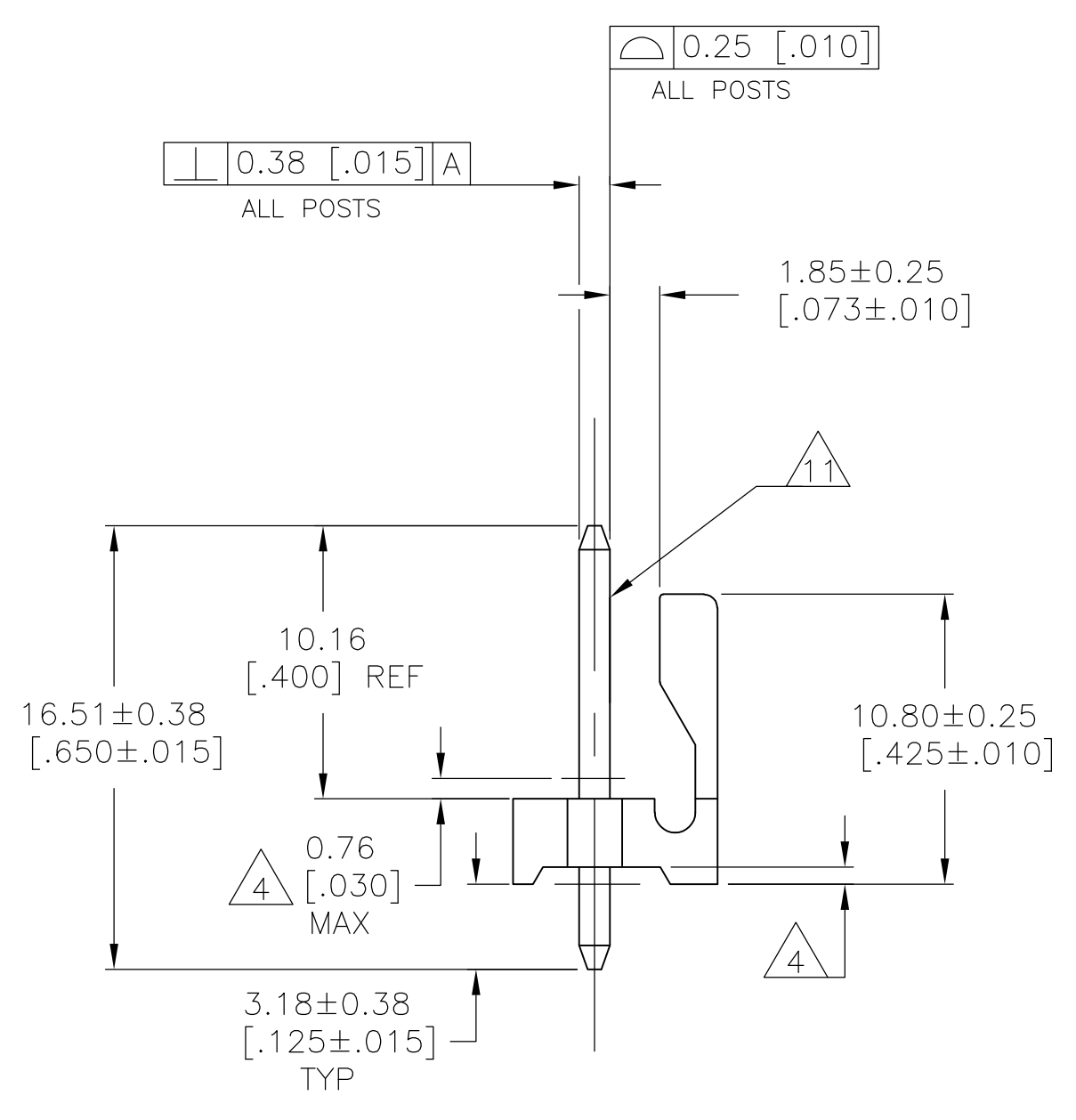
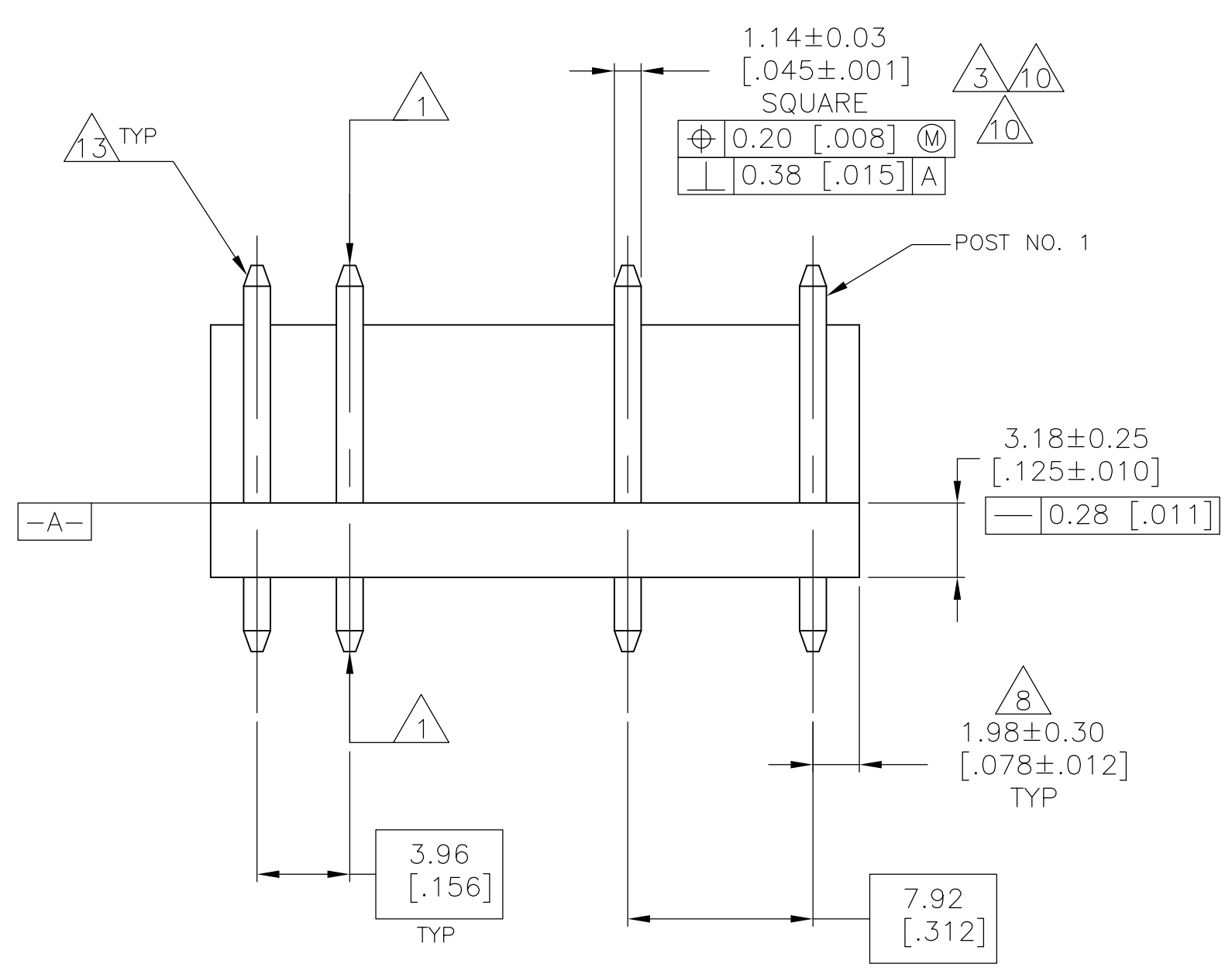
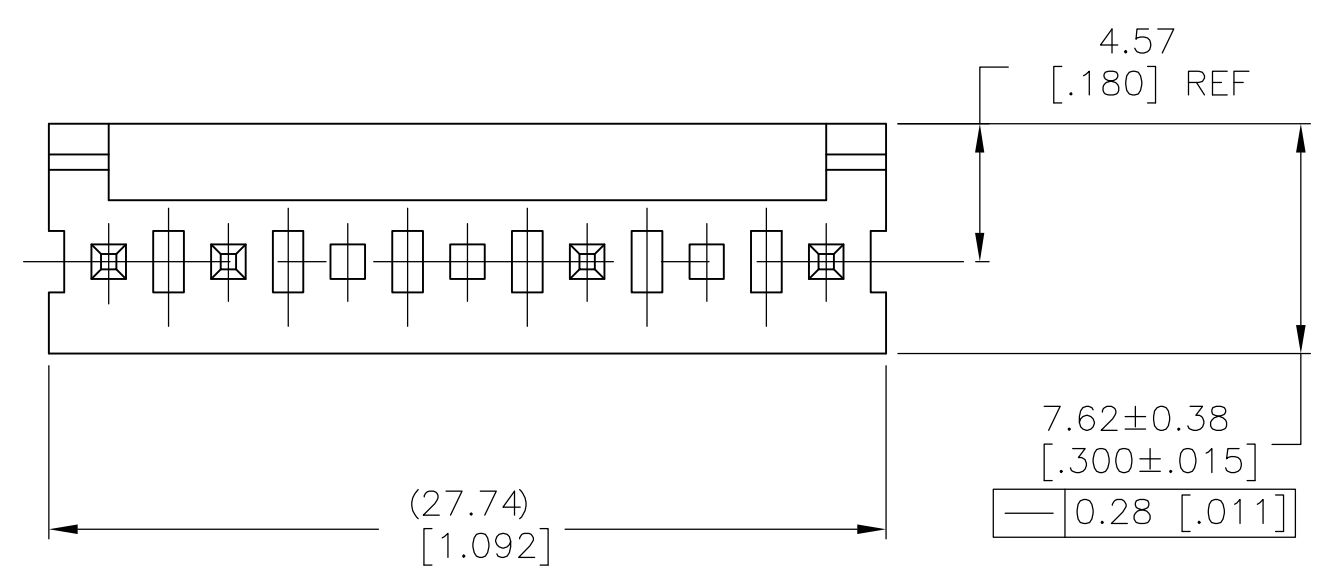

- 1 POST TO WITHSTAND 13 NEWTONS (3 LBS.) MIN. AXIAL FORCE IN BOTH DIRECTIONS SHOWN WITHOUT DISLODGING.
- 2 TOLERANCES APPLY TO SOLDER SIDE OF BOARD.
- 3 MEASURED AT SURFACE -A-
- 4 PLASTIC FLASH PERMITTED IN THIS AREA.
- 5 PARTS COMPLY WITH AMP SOLDER ABILITY SPEC. NO. 109-11-2
- 6 ONE HOLE MAY BE UNDERSIZED 1.65/1.52 [0.065/0.060] DIA. FOR ASSEMBLY RETENTION DURING WAVE SOLDERING.
- 7 MATERIAL: HEADER-THERMOPLASTIC POLYESTER
GLASS-FILLED 94-0 (NATURAL)
POST-COPPER ALLOY (TIN PLATED)
- 8 COORDINATE DIMENSIONS APPLIES FROM CENTER OF ACTUAL FEATURE.
- 9 PLASTIC BURRS CAUSED BY CUTOFF TOOLING ARE PERMITTED WITHIN THE MAXIMUM TOLERANCE ENVELOPE.
- 10 POST TO BE MEASURED WHEN STRIP IS HELD FLAT.
- 11 POST MUST WITHSTAND TWO 90° BENDS AGAINST EXTRUSION WITHOUT BREAKING.
- 12 DIMENSION SHOULD BE .175 MIN WHEN MATING WITH A MTA .156 CONNECTOR ASSY. OR A SL-.156 CONNECTOR ASSY.
- 13 PIN BURR OF .005 MAX. VERTICAL AND .003 MAX. HORIZONTAL PERMITTED AT POST TIPS ON BOTH ENDS.
- 14 SPECIAL PACKAGING VARIATION FOR IMPROVED PRODUCT PROTECTION.

5	2-643464-3
2	2-643464-2
1,4,&6	1-643464-4
2 & 5	1-643464-3
2,4,&5	1-643464-2
2,3,5,&6	1-643464-1
4&6	1-643464-0
3,6	643464-9
4	643464-7
2,4,&6	643464-6
6	643464-5
3	643464-4
5	643464-3
2	643464-2
2 & 4	643464-1
POST NUMBER OMITTED	PART NUMBER

1-643464-2 SHOWN

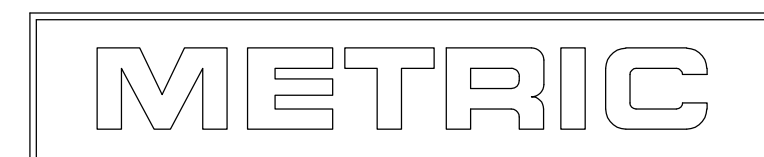

THIS DRAWING IS A CONTROLLED DOCUMENT.		DWN S. HOOVER 22MAY02	Tyco Electronics Corporation Harrisburg, PA 17105-3608
DIMENSIONS: mm [INCHES]		CHK D. BOSSI 22MAY02	
TOLERANCES UNLESS OTHERWISE SPECIFIED:		NAME D. BOSSI 22MAY02	MTA -156 HEADER ASSEMBLY, FRICTION LOCK, STRAIGHT, .045 SQUARE POST, TIN PLATED, 7 POSITION, OMITTED POST
0. PLC ±		PRODUCT SPEC	
1. PLC ±		APPLICATION SPEC	SIZE A1
2. PLC ±		WEIGHT	CAGE CODE 00779
3. PLC ± .005		CUSTOMER DRAWING	SCALE 4:1
4. PLC ±			SHEET 1 OF 1
ANGLES ±			REV AA
FINISH			