

Customer Information Sheet

DRAWING No.: H3151-XX

SHEET 2 OF 2

IF IN DOUBT - ASK

©

NOT TO SCALE

THIRD ANGLE PROJECTION

ALL DIMENSIONS IN mm

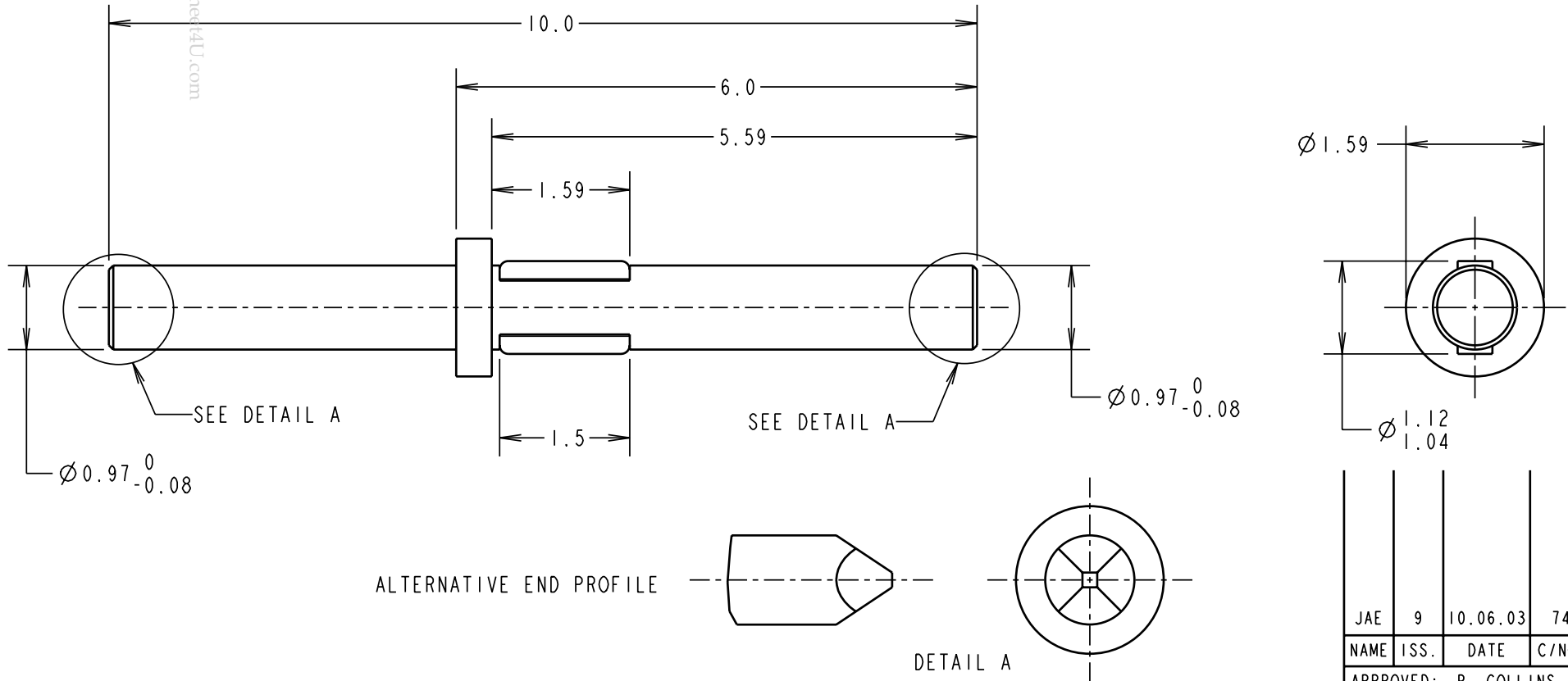

NOTES:

1. RECOMMENDED MOUNTING HOLE SIZE = $\varnothing 0.99-1.04$ mm.
2. RECOMMENDED PANEL THICKNESS = 1.6-2.4mm.
3. PUNCH & DIE TOOL PART No. = Z3151-00.

PART No.	FINISH
H3151-00	UNPLATED
H3151-01	7.6 μ 90/10 TIN/LEAD

JAE	9	10.06.03	7476
NAME	ISS.	DATE	C/NOTE
APPROVED: P. COLLINS			
CHECKED: W. J. BOURNE			
DRAWN: K. SHIER			
CUSTOMER REF.:			
ASSEMBLY DRG:			

HARWIN

THIS DRAWING AND ANY INFORMATION OR DESCRIPTIVE MATTER SET OUT HEREON ARE CONFIDENTIAL AND COPYRIGHT PROPERTY OF THE HARWIN GROUP AND MUST NOT BE DISCLOSED, LOANED, COPIED OR USED FOR MANUFACTURING, TENDERING OR FOR ANY OTHER PURPOSE WITHOUT THEIR WRITTEN PERMISSION.

TOLERANCES
 X. = ± 1 mm
 X.X = ± 0.25 mm
 X.XX = ± 0.10 mm
 X.XXX = ± 0.01 mm
 ANGLES = $\pm 5^\circ$
 UNLESS STATED

MATERIAL:
 BRASS CW508L TO BS EN 1652 (CuZn37)
FINISH: SEE TABLE
S/AREA: mm²

TITLE:
 COLD FORM
 TERMINAL PIN

DRAWING NUMBER:
 H3151-XX

SHT
 2 OF 2

HARWIN INC U.S.A. TEL: (812) 542 2546 FAX: (812) 542 2541	HARWIN PLC U.K. TEL: 023 9237 0451 FAX: 023 9231 4590	HARWIN PTE SINGAPORE TEL: 65 6779 4909 FAX: 65 6779 3868
---	---	--