

PBL 3726/16 Universal Speech Circuit

Description

PBL 3726/16 is a standard version of the PBL 3726 family of mask-programmable, monolithic integrated speech circuits for use in electronic telephones.

It is designed for use with a low impedance microphone. Transmitting and receiving gain is regulated with line length. Different regulation for various current feeds can be set by external resistors. Typical current feeds as 48 V 2 x 200 ohm, 48 V 2 x 400 ohm and 36 V 2 x 500 ohm can be handled. Application dependent parameters such as line balance, side tone level, amplification and frequency response are set by external components. Parameters are set independently which means easy adaption for various market needs. An uncommitted on-chip amplifier can be used for different purposes, for example to provide an additional 20 dB receiving gain with volume control or line-length controlled side tone balancing.

Key Features

- Minimum number of inexpensive external components, 5 capacitors and 10 resistors.
- Mute function for parallel operation with DTMF-generator.
- Transmit and receive gain regulation for automatic loop loss compensation.
- Side tone balance regulated with line length for good side tone level on all line lengths.
- Extended current range 5-130 mA and voltage down to 2 V.
- Differential microphone input for good balance to ground. (Common mode rejection)
- Balanced receiver output stage.
- Amplifier for extra 20 dB receiving gain with volume control.
- The receiver output drive capability is adjustable.

DataSheet4U.com

DataSheet4U.com

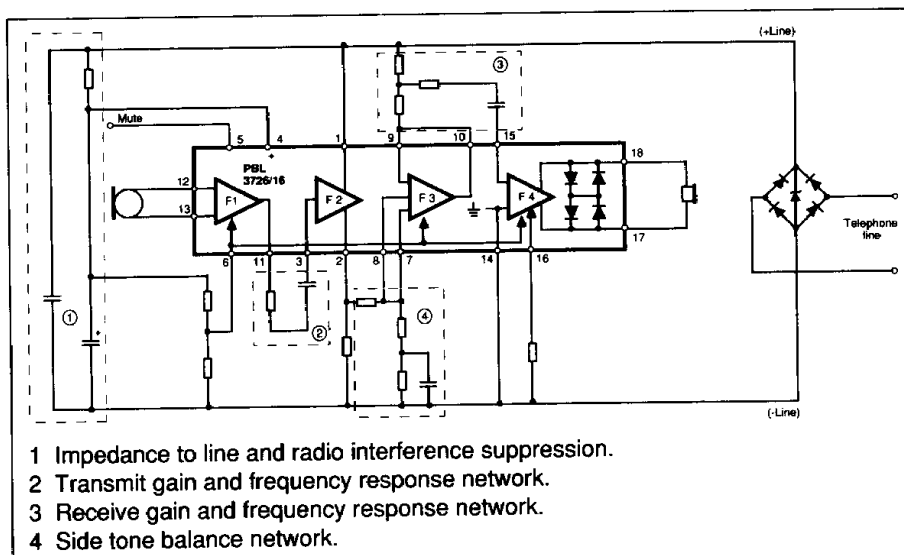
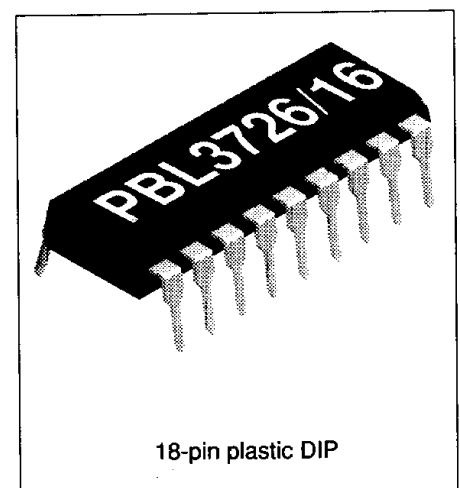

Figure 1. Functional diagram.



Maximum Ratings

Parameter	Symbol	Min	Max	Unit
Line voltage, $t_p = 2$ s	V_L	0	22	V
Line current, continuous	I_L	0	130	mA
Operating temperature range	t_{Amb}	-40	+70	°C
Storage temperature range	t_{Stg}	-55	+125	°C

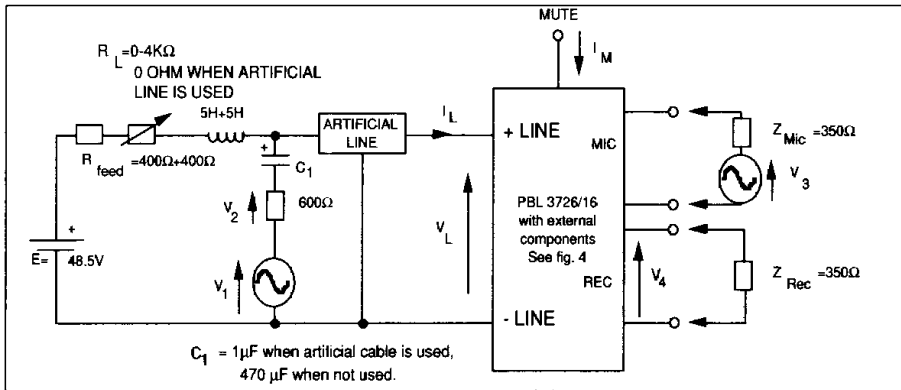

Figure 2. Test setup without rectifier bridge.

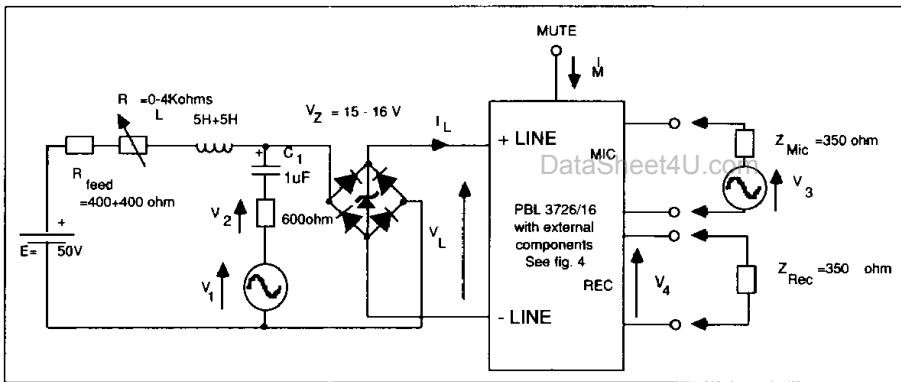

Figure 3. Test setup with rectifier bridge.

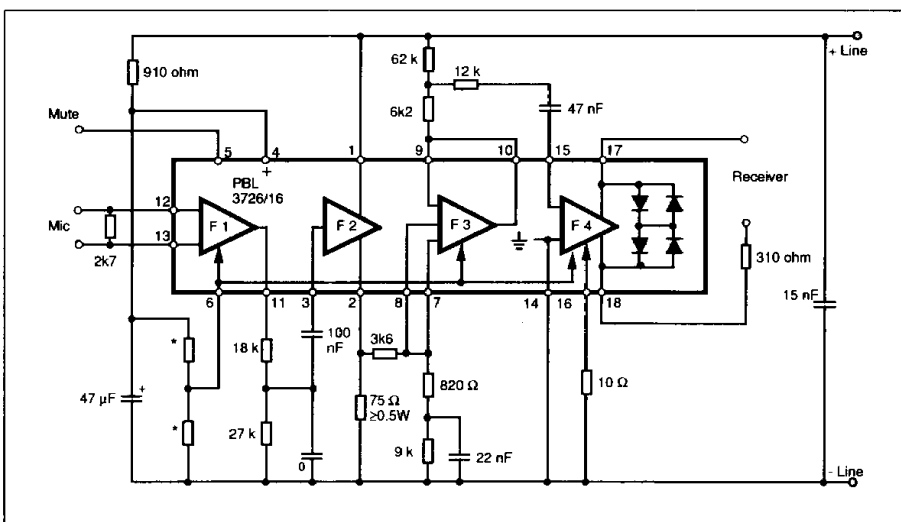

Figure 4. Circuit with external components for test setup.

Electrical Characteristics

At $t_{Amb} = +25\text{ }^{\circ}\text{C}$. No cable and no line rectifier unless otherwise specified.

Parameter	Ref. fig.	Conditions	Min	Typ	Max	Unit
Line voltage, V_L	2	$I_L = 15\text{ mA}$	3.3	3.7	4.1	V
	2	$I_L = 100\text{ mA}$	11	13	15	V
Transmitting gain (note 1)		$20 \cdot 10 \log (V_2/V_3)$; 1 kHz				
	2	$R_L = 0\ \Omega$	41	43	45	dB
	2	$R_L = 400\text{ ohm}$	43.5	45.5	47.5	dB
	2	$R_L = 900\text{ ohm}-2.2\text{ kohm}$	46	48	50	dB
Transmitting range of regulation	2	1 kHz				
		$R_L = 0\text{ to }900\text{ ohm}$	3	5	7	dB
Transmitting frequency response	2	200 Hz to 3.4 kHz	-1		1	dB
Receiving gain (note 1)		$20 \cdot 10 \log (V_4/V_1)$; 1 kHz				
	2	$R_L = 0\text{ ohm}$	-18.5	-16.5	-14.5	dB
	2	$R_L = 400\text{ ohm}$	-16	-14	-12	dB
	2	$R_L = 900\text{ ohm}-2.2\text{ kohm}$	-13.5	-11.5	-9.5	dB
Receiving range of regulation	2	1 kHz, $R_L = 0\text{ to }900\text{ ohm}$	3	5	7	dB
Receiving frequency response	2	200 Hz to 3.4 kHz	-1		1	dB
Microphone amplifier input impedance		See note 3		1.7(//2.7)		kohm
Transmitter input impedance	2	1 kHz		17		kohm
Transmitter dynamic output	2	200 Hz-3.4 kHz, $\leq 2\%$ distortion		1.5		V_p
		$I_L = 20-100\text{ mA}$				
Transmitter max output	2	200 Hz-3.4 kHz, $I_L = 0-100\text{ mA}$		3		V_p
		$V_3 = 0-1\text{ V}$				
Receiver output impedance	2	1 kHz (see note 3)		3(+310)		ohm
Receiver dynamic output (see note 2)	2	200 Hz-3.4 kHz, $\leq 2\%$ distortion		0.5		V_p
		$I_L = 20-100\text{ mA}$				
Receiver max output	3	Measured with line rectifier 200 Hz-3.4 kHz, $I_L = 0-100\text{ mA}$ $V_1 = 0-50\text{ V}$		0.9		V_p
Transmitter output noise	2	Psoph-weighting, Rel 1 V_{rms} , $R_L = 0\ \Omega$		-75		dB
Receiver output noise	2	A-weighting, Rel 1 V_{rms} , with cable,		-85		dB
		0-5 km $\varnothing=0.5\text{ mm}$,				
		0-3 km $\varnothing=0.4\text{ mm}$.				
Mute input current, I_M	2		0.1			mA
Extra available current when muted at the same DC voltage.	2	$I_L = 15-100\text{ mA}$		10		mA

Notes

- Adjustable to both higher and lower values with external components.
- The dynamic output can be doubled. See application notes.
- External resistor in the test set up.

Pin Descriptions

Refer to figure 5 (package)

Pin	Symbol	Description
1	+L	Output of the DC-regulator and transmit amplifier. This pin is connected to the line through a polarity guard diode bridge.
2	TO	Output of the transmit amplifier. This pin is connected to -L via a resistor of 47 to 100 ohm, which sets the DC-resistance of the circuit. The output has a low AC output impedance. The output signal is used to drive a side tone balancing network.
3	TI	Input of transmit amplifier. Input impedance, 17 kohm \pm 20%.
4	+C	The positive power supply terminal for most of the circuitry inside the PBL 3726/16 (about 1 mA current consumption). The +C-pin shall be connected to a decoupling capacitor of 47 μ F to 150 μ F.
5	Mute	Mute input. Requires min 100 μ A to mute microphone and receiver amplifier.
6	GR	Control input for the gain regulation circuitry. (Input impedance, 5.5 k Ω \pm 20 %).
7	AI 1	Positive inputs to a separate, line-length controlled amplifier (F3), which works as a buffer regulating amplifier in the sidetone balance loop. At short lines, pin 8 is deactivated and F3 only uses the signal coming from the side tone balance network connected to pin 7. For long lines, the opposite is true. At intermediate line lengths there is a graded switchover with both inputs partly activated. With pin 7 and 8 tied together, amplifier F3 is line length independent.
8	AI 2	
9	AI 3	This pin is a line length independent negative input to the separate amplifier. (F3)
10	AO	This pin is the output of the separate amplifier. (F3)
11	MO	Output of the microphone amplifier.
12	MI 1	Input to the microphone amplifier.
13	MI 2	Input impedance 1.7 kohm \pm 20 %.
14	-L	The negative power terminal, connected to the line through a polarity guard diode bridge.
15	RI	Input of receiver amplifier. Input impedance is approximately 38 kohm \pm 20%.
16	DR	The control input of the receiver amplifier. The input controls the driving capability.
17	RE 2	Receiver amplifier outputs. Output impedance approximately 3 ohm.
18	RE 1	

et4U.com

DataSheet4U.com

DataShee

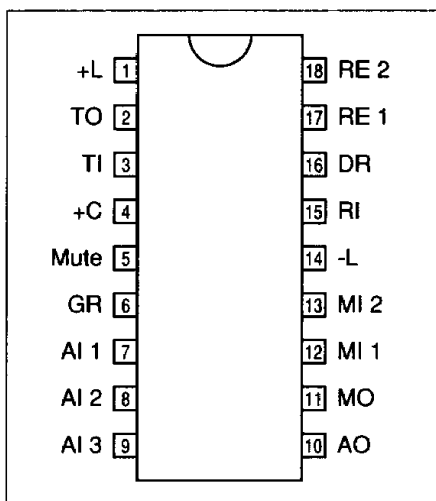

Figure 5. Pin configuration.

Functional Description

General

PBL 3726/16 contains all the necessary line interface functions of a modern electronic telephone.

The circuit uses a minimum of external components. In a typical application only 5 external capacitors are needed of which one is an electrolytic or tantalum filter capacitor. The other capacitors are needed as radio interference suppression capacitor across the line, one capacitor in the side-tone balancing network and one capacitor for low frequency cut-off in each of the transmitting and receiving amplifiers. The frequency response is, except for that, flat for both amplifiers.

The circuit includes a temperature independent voltage reference used for regulation of the DC line voltage and for the transmitting and receiving gain regulation. The DC voltage is very fast settled to its final value with a minimum of overshoot.

The gain of the transmitting and receiving amplifiers are continuously and equally changed with the line length. The starting point of the gain regulation is externally set at pin 6. The gain regulation can be cut-off externally, and the gain will then be the maximum gain normally used at long lines.

The receiver amplifier is equipped with a high impedance input stage. This

gives a less expensive RC-network on the input.

Only resistive elements are used to set the receiving gain.

A push-pull power stage in the receiving amplifier gives a high output swing.

The outputs of the transmitting and receiving amplifiers have internal limitations of the output amplitudes.

The circuit will with external compo-

nents get very good return loss characteristics, both against purely resistive lines like for instance 600 ohm and against complex networks like 900 ohm in parallel with 30 nF.

The microphone input is balanced for optimal common mode rejection.

It is possible to add a push-button controlled cut-off of the transmitting amplifier to the circuit without any disturbance of the other circuit functions.

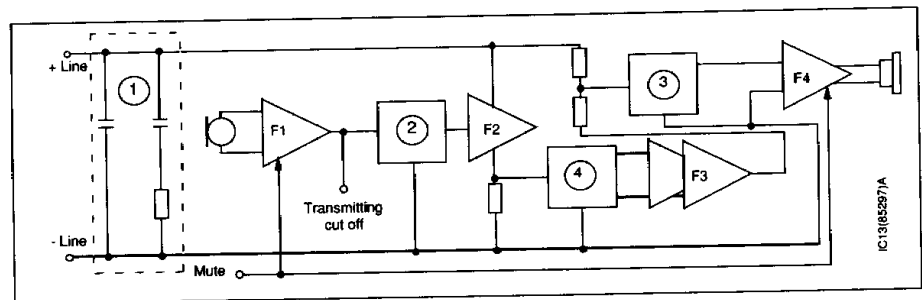

Figure 6. Block interconnections.

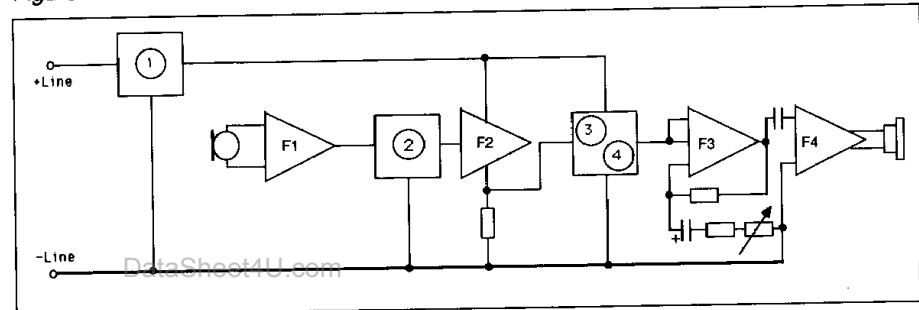

Figure 7. Alternative block interconnections.

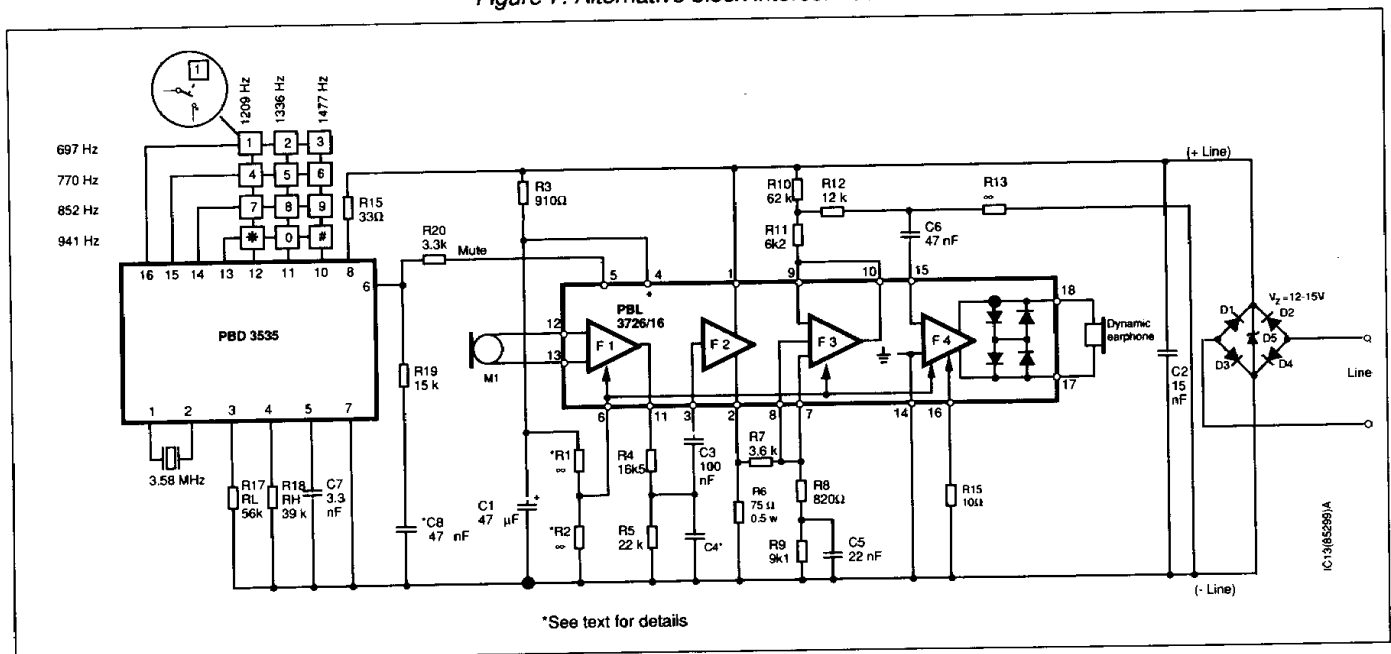

Figure 8. Typical tone dialling telephone.

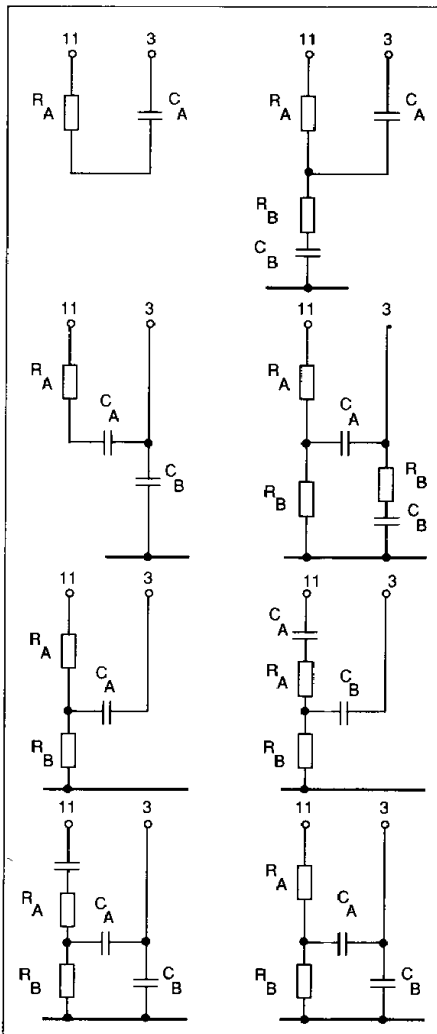

Figure 9. Examples of network "2".

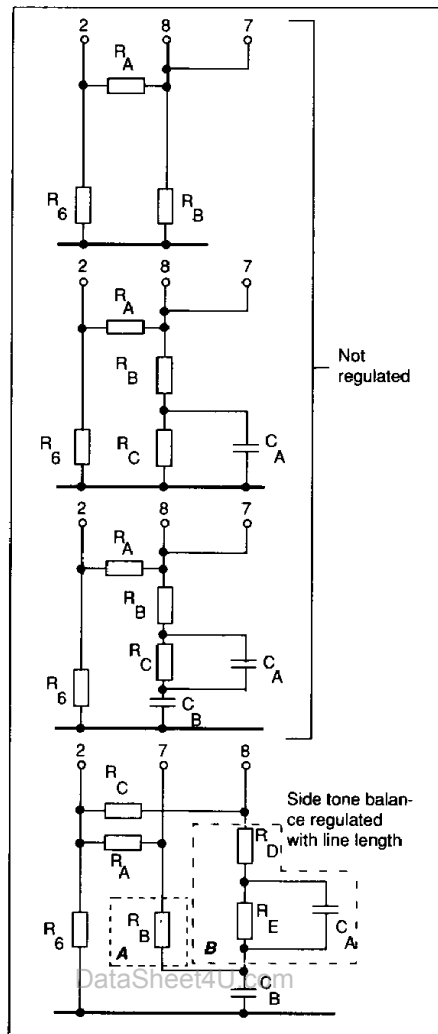

Figure 10. Examples of network "3".

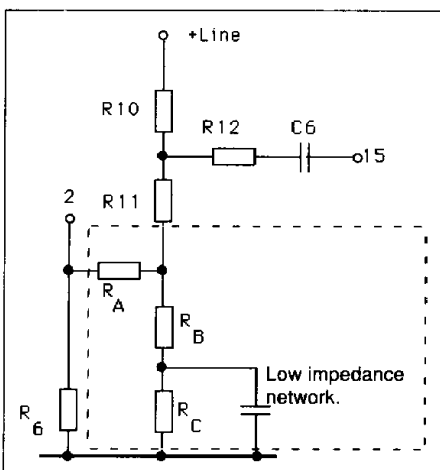

Figure 11. Connections without using F3 as buffer for the side-tone network.

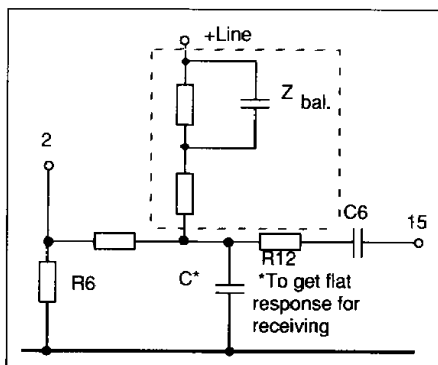

Figure 12. Alternative connections without using F3.

A mute input is included in the circuit. It gives:

1. Cut-off the microphone amplifier. (F1).
2. Reduced gain in the receiving amplifier. (F4).
3. Power down to reduce the current consumption.

When mute signal is applied on the circuit it reduces its power consumption and adjusts the DC regulation accordingly. This makes it possible to use a DTMF generator like Ericsson's PBD 3535 and still have the same DC characteristics during dialling.

The side-tone balance can be set by a RC-network not influencing other parameters. An inexpensive solution requires only one capacitor but additional capacitors give better performance. The side-tone can be regulated with respect to line length. (See pin function, pin 7 and 8.)

A separate amplifier stage (F3) can be used in several different ways, for instance

1. Separating the side-tone balancing network.
2. Line length compensation of side tone level. (See fig. 6).
3. Give an extra 20 dB gain with volume control for the receiving amplification etc. (See fig. 7).

RC-links ①②③ and ④ in fig. 6 and 7 have the following function:

1. Radio interference suppression and to give the correct return loss behavior.
2. Gain and frequency response for transmitting.
3. Gain and frequency response for receiving.
4. Side-tone level (regulation with line length is possible).

Applications Information

Refer to figure 8.

Gain regulation, (R1, R2):

Resistors R1, R2 set the starting point for the gain- and side tone regulation.

See table below for typical values of R1 and R2.

Battery feed	R1	R2	R6
No regulation. Set for short line gain, All feedings.	∞	22k Ω	47-100 Ω
Regulation:			
48 V, 2 x 200 Ω	∞	∞	47 Ω
48 V, 2 x 400 Ω	∞	∞	75 Ω
36 V, 2 x 500 Ω	∞	120k Ω	100 Ω

Previous users of PBL 3726/6 to 3726/15 might note that the two resistors works the opposite way and that only one or none of them is necessary.

Impedance to the line, (R3, C1, C2):

C1 in series with R3 and those in parallel with C2 give the impedance to the line from the set. (C2 also suppresses radio interference.)

The time constant R3, C1 should be kept sufficiently large, not to generate distortion at low frequencies.

Changing R3 will affect the DC-characteristics set at pin 4. The input current at pin 4 is approx. 1 mA.

Microphone selection, (M1):

The microphone can be either dynamic, magnetic or electret. (See figures 17, 18 and 19.)

Transmitting gain and frequency response, (R4, R5, C3, C4):

The network sets the amplification and frequency response of the transmitter. R5 is used when a larger reduction of the gain is required. The sum of the resistors R4 and R5 must not be less than 35 kohm because of DC-current to ground. (See fig. 9 for typical applications).

DC-characteristics, (R6):

Apart from setting the DC characteristics, R6 also gives circuit protection by dissipating some of the supplied power. Note that changing R6 will affect transmit gain, gain regulation and sidetone. Common values are 47 ohm to 100 ohm.

Side tone level, receiving gain and frequency response, (R7, R8, R9, R10, R11, C5):

The network sets the side tone balance. The network in the application is one of many possibilities. R10 and R11 balance together the signals that go two different ways from the transmitter output

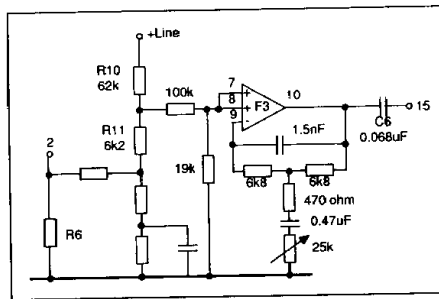

Figure 13. F3 used for 20dB additional receiving gain.

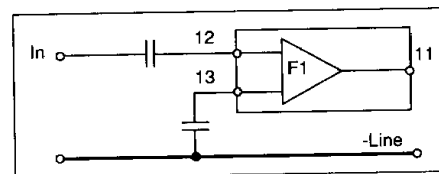

Figure 14. Single-ended microphone input.

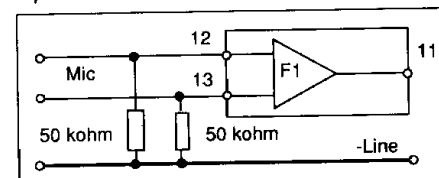

Figure 15. Connections for extended low-voltage operation.

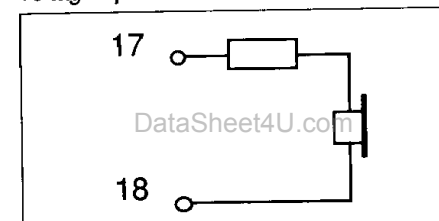

Figure 16. Using a magnetic receiver.

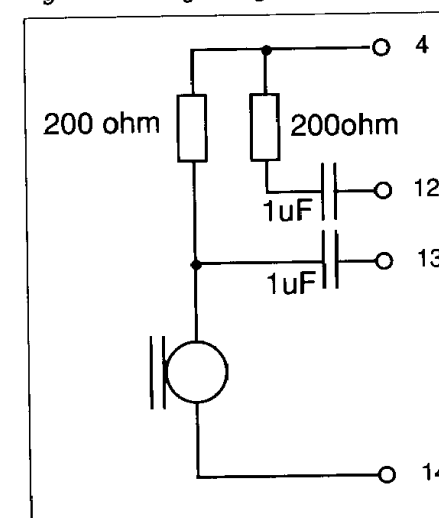

Figure 17. Using an electret microphone with built-in FET buffer.

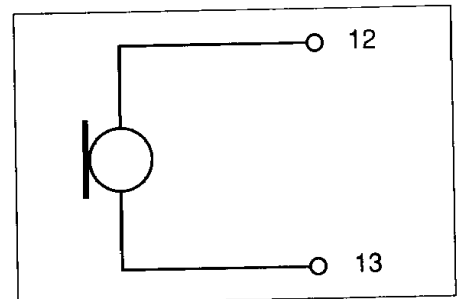

Figure 18. Connections of a dynamic microphone.

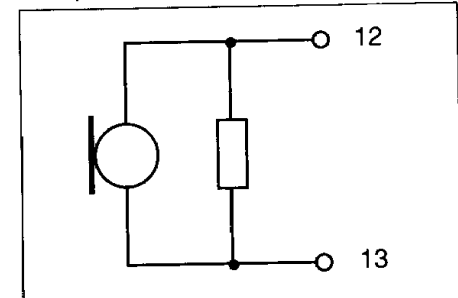

Figure 19. Using a magnetic microphone.

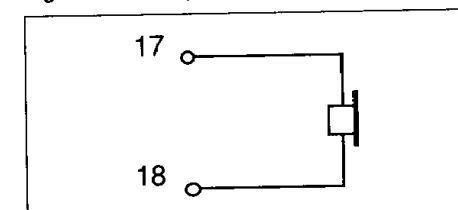

Figure 20. Using a dynamic earphone.

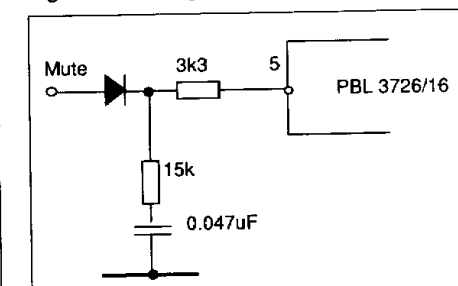

Figure 21. Click-reducing circuit.

stage, one from pin 1 and the other (in opposite phase) from pin 2. The balance network consist of R8, R9 and C5.

The example is not optimized to any specified line, it is only given to show the principle. The inputs of the amplifier F3 is high ohmic. For some different side-tone networks, see fig. 10.

Design of a side tone network with regulation according to above can be done as follows. (Fig. 10).

The balance impedance A is optimized at a short line where the regulation start. The balance impedance B is optimized at a long line where the regulation stops. The circuit generates a continuous change between the two balance impedances.

Fig. 11 and 12 are two examples of balance networks without F3. F3 can then be used for other purposes.

By breaking up between pin 9 and 10, F3 can be used as an amplifier with amplification higher than one (fig 13).

R12, R13, C6, (R10, R11):

The networks gives the gain and frequency response for the receiver.

R13 is used when a greater reduction of the gain is wanted. For different

possibilities for the design of the network, see the network for the transmitter (R4, R5, C3).

REC, R14

R14 generates the output impedance for a magnetic earphone, see figure 16. If a dynamic earphone is used it should be placed between pin 17 and 18 (fig.20).

This will double the available swing voltage (at the same output current).

R15:

This resistor is used to set the driving capability of the receiver output amplifier. Common values are 0 ohm to 50 ohm. Setting it for low driving capability results in function at lower line current.

D1, D2, D3, D4, D5:

Rectifier bridge and overvoltage protector. The zenervoltage at D5 should be as low as possible. Common values are between 12 V - 16 V.

Design procedure:

1. The circuits impedance to the line.
2. DC-characteristic
3. Gain regulation.

4. Transmitter gain and frequency response.
5. Receiver gain and frequency response.
6. Side-tone.
7. Components to surpress radio interference, specially the wires up to the handset.

Others:

The circuit can be placed either in the telephone or in the handset.

The circuit can be proved with an unbalanced according to figure 14.

In order to improve performance at low line currents and voltages (5mA, 2V), connect two 50kΩ resistors from the microphone inputs to ground as indicated in figure 15.

Cut-off of the transmitter can be done at F1 without interference of other functions of the circuit.

A circuit to reduce disturbing clicks during dialling is shown in figure 21. The diode is not needed when the PBD 3535 DTMF generator is used.

Information given in this data sheet is believed to be accurate and reliable. However no responsibility is assumed for the consequences of its use nor for any infringement of patents or other rights of third parties which may result from its use. No license is granted by implication or otherwise under any patent or patent rights of Ericsson Components. These products are sold only according to Ericsson Components' general conditions of sale, unless otherwise confirmed in writing.

Specifications subject to change without notice.

IC4 (88086) A-Ue

© Ericsson Components AB 1987

ERICSSON 

Ericsson Components AB
S-164 81 Kist-Stockholm, Sweden
Telephone: (08) 757 50 00

Ordering Information

Package	Temp. Range
Plastic DIP	-40 to +70°C

Part No.
PBL 3726/16N