

## SDC1700/1702/1704 SERIES

### FEATURES

Internal Microtransformers for 60Hz, 400Hz and 2.6kHz References

Low Profile (0.4")

10-, 12- or 14-Bit Resolution for 360°

High Tracking Rates (75 revs/sec)

Voltage Scaling with External Resistors (Unique Feature)

DC Voltage Output Proportional to Angular Velocity

Low Cost

Lightweight 3oz. (85 grams)

MIL Spec/Hi Rel Options Available

### APPLICATIONS

Servo Mechanisms

Retransmission Systems

Coordinate Conversion

Antenna Monitoring

Simulation

Industrial Controls

Fire Control Systems

Machine Tool Control Systems

### GENERAL DESCRIPTION

The SDC1700, SDC1702 and SDC1704 are modular, continuous tracking Synchro/Resolver-to-Digital Converters which employ a type 2 servo loop.

They are intended for use in both Industrial and Military applications.

The input signals can be either 3 wire synchro plus reference or 4 wire resolver plus reference, depending on the option. The outputs will be presented in TTL compatible, parallel natural binary.

One of the outstanding features of the converters is the use of precision Scott T and reference microtransformers. *This has made it possible to include the transformers within the module, even on the 60Hz option, and yet still maintain the profile height of 0.4".*

Particular attention has been paid in the design, to achieving the highest tracking rates and accelerations possible, compatible with the resolution and carrier frequency used, while at the same time obtaining a high overall accuracy.

When SDC's are used in control loops, it is often useful to have a voltage which is proportional to angular velocity. This voltage is available and has been brought out on all the SDC1700 converters.

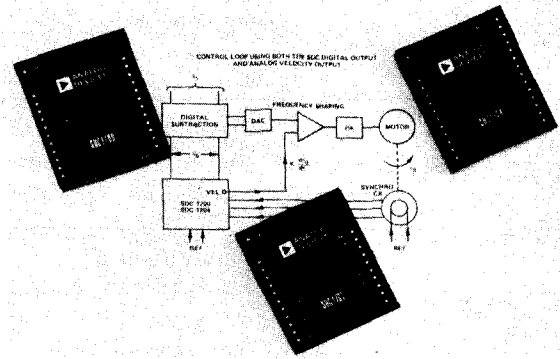

Extended temperature range versions of all the converters are available.

### MODELS AVAILABLE

The three Synchro-to-Digital Converters described in this data sheet differ primarily in the areas of resolution, accuracy and dynamic performance as follows:

Model SDC1702XYZ is a 10-bit converter which has an overall accuracy of  $\pm 22$  arc-minutes and a resolution of 21 arc-minutes.

Model SDC1700XYZ is a 12-bit converter with an overall accuracy of  $\pm 8.5$  arc-minutes and a resolution of 5.3 arc-minutes.

Model SDC1704XYZ is a 14-bit converter with an overall accuracy of  $\pm 2.2$  arc-minutes  $\pm 1$ LSB and a resolution of 1.3 arc-minutes.

The XYZ code defines the option thus: (X) signifies the operating temperature range, (Y) signifies the reference frequency, (Z) signifies the input voltage and range, and whether it will accept synchro or resolver format.

More information about the option code is given under the heading of "Ordering Information".

### NOTE

For all the standard options, no external transformers are needed with these converters.

# SPECIFICATIONS (typical @ +25°C unless otherwise noted)

| MODELS   | SDC1702   | SDC1700  | SDC1704                           |
|--|---|--|-----------------------------------|
| ACCURACY <sup>1</sup> (max error)                  |   |  |                                   |
| 60Hz   | ±22 arc-minutes   | ±8.5 arc-minutes                               | ±2.9 arc-minutes ±1LSB            |
| 400Hz  | ±22 arc-minutes   | ±8.5 arc-minutes                               | ±2.2 arc-minutes ±1LSB            |
| 2.6kHz   | ±22 arc-minutes   | ±8.5 arc-minutes                               | ±2.9 arc-minutes ±1LSB            |
| RESOLUTION   | 10 Bits (1LSB = 21 arc-mins)  | 12 Bits (1LSB = 5.3 arc-mins)                  | 14 Bits (1LSB = 1.3 arc-mins)     |
| OUTPUT (In Parallel)                               | 10 Bits (Natural Binary)  | 12 Bits (Natural Binary)                       | 14 Bits (Natural Binary)          |
| SIGNAL AND REFERENCE FREQUENCY                     | 60Hz, 400Hz, 2.6kHz   | *  | *                                 |
| SIGNAL VOLTAGE (Line-to-Line)                      |   |  |                                   |
| Low Level  | 11.8V rms   | *  | *                                 |
| High Level   | 90V rms   | *  | *                                 |
| SIGNAL IMPEDANCES                                  |   |  |                                   |
| Low Level  | 26kΩ (Resistive)  | *  | *                                 |
| High Level   | 200kΩ (Resistive)   | *  | *                                 |
| REFERENCE VOLTAGE                                  |   |  |                                   |
| Low Level  | 26V (±1.8V Signal)  | *  | *                                 |
| High Level   | 115V (90V Signal)   | *  | *                                 |
| REFERENCE IMPEDANCE                                | 270kΩ (115V Signal)<br>56kΩ (26V Reference)<br>(Impedance is Resistive) | *  | *                                 |
| TRANSFORMER ISOLATION                              | 500V dc   | *  | *                                 |
| TRACKING RATE (min)                                |   |  |                                   |
| 60Hz   | 5 Revolutions Per Second  | *  | 500°/sec                          |
| 400Hz  | 36 Revolutions Per Second   | *  | 12 Revolutions Per Second         |
| 2.6kHz   | 75 Revolutions Per Second   | *  | 25 Revolutions Per Second         |
| Accel. <sup>1</sup>                                |   |  |                                   |
| Constant K <sub>a</sub>                            |   |  |                                   |
| 60Hz   | 1880/sec <sup>2</sup>   | *  | 520/sec <sup>2</sup>              |
| 400Hz  | 110,000/sec <sup>2</sup>  | *  | 36,000/sec <sup>2</sup>           |
| 2.6kHz   | 518,000/sec <sup>2</sup>  | *  | 170,000/sec <sup>2</sup>          |
| STEP RESPONSE (179° Step)<br>(For 1LSB Error)      |   |  |                                   |
| 60Hz   | 1.5sec  | *  | *                                 |
| 400Hz  | 125ms   | *  | *                                 |
| 2.6kHz   | 50ms  | *  | *                                 |
| POWER LINES  | ±15V @ 25mA } ±5%<br>+5V @ 70mA }                                       | *  | ±15V @ 30mA } ±5%<br>+5V @ 85mA } |
| POWER DISSIPATION                                  | 1.1 Watts   | *  | 1.3 Watts                         |
| DATA LOGIC OUTPUT <sup>2</sup><br>(TTL Compatible) | 2TTL Loads SDC17026YZ<br>4TTL Loads SDC17025YZ                          | 2TTL Loads SDC17006YZ<br>4TTL Loads SDC17005YZ | 2TTL Loads on<br>All Options      |
| BUSY LOGIC OUTPUT, POSITIVE PULSE (1 TTL Load)     |   |  |                                   |
| 60Hz   | 9.0μs } ±30%  | *  | 9.0μs } ±30%                      |
| 400Hz  | 2.0μs }   | *  | 2.0μs }                           |
| 2.6kHz   | 2.0μs }   | *  | 1.3μs }                           |
| MAX DATA TRANSFER TIME                             |   |  |                                   |
| 60Hz   | 40μs  | *  | 35μs                              |
| 400Hz  | 5.0μs   | *  | 3.0μs                             |
| 2.6kHz   | 1.8μs   | *  | 0.8μs                             |
| INHIBIT INPUT (To Inhibit)                         | Logic "0" 1 TTL Load  | *  | Logic "0" 2 TTL Loads             |
| WARM UP TIME                                       | 1 sec to Rated Accuracy   | *  | *                                 |
| TEMPERATURE RANGE                                  |   |  |                                   |
| Operating  | 0 to +70°C Standard<br>-55°C to +105°C Extended                         | *  | *                                 |
| Storage  | -55°C to +125°C   | *  | *                                 |
| DIMENSIONS   | 3.125" x 2.625" x 0.4"<br>(79.4 x 66.7 x 10.2mm)                        | *  | *                                 |
| WEIGHT   | 3 ozs. (85 grams)   | *  | *                                 |

## NOTES

\*Specifications same as SDC1702.

<sup>1</sup> Specified over the appropriate operating temperature range of the option and for:  
(a) ±10% signal and reference amplitude variation (b) 10% signal and reference Harmonic Distortion (c) ±5% power supply variation (d) ±10% variation in reference frequency.

<sup>2</sup> It is recommended that buffers should be used if the above converters are required to drive over a distance greater than 6'.

Specifications subject to change without notice.

### DATA TRANSFER (All Models)

The readiness of the converters for data transfer is indicated by the state of the BUSY pin.

The voltage appearing on the BUSY pin consists of a train of pulses, at TTL levels, of length according to the model and option (see specification table). The converter is busy when the BUSY pin is at a TTL "High" level. These pulses correspond to those delivered by the VCO to increment or decrement the up-down counter (see schematic diagram). Thus the pulses will occur for increasing and decreasing counts.

The most suitable time for transferring data is when the BUSY is at a logic "Lo" state, and the times allowable for data transfer are shown in the specification. Even at the maximum speed of the option, these times will be sufficient to transfer data before the next BUSY pulse occurs.

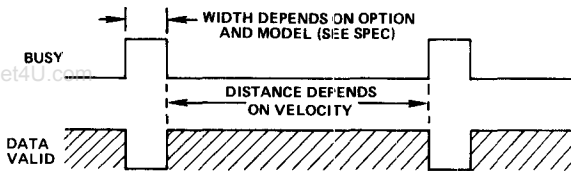

Data Transfer Diagram

### DATA TRANSFER DIAGRAM

Taking the INHIBIT to a logic "Lo" state prevents the VCO (BUSY) pulses from updating the up-down counter. However, if applied during a BUSY pulse, the INHIBIT will not become effective until the end of the BUSY pulse.

The best method of transferring the data is by applying the INHIBIT (taking it to a logic "Lo" state), waiting for at least the width of a BUSY pulse, transferring the data and releasing the INHIBIT.

Note that sustained application of the INHIBIT opens the internal control loop and the converter may take on appreciable time to recover to full accuracy when the loop is restored.

### INTERFACING WITH A COMPUTER

It is recommended that external latches are used to enable data to be transferred onto a computer data bus. One method is shown in the diagram. Using this method will mean that the latches are constantly updated by the BUSY signal, while at the same time enabling inputs to be made to the computer by means of normal data transfer procedures. The AC1755 mounting card contains these external components.

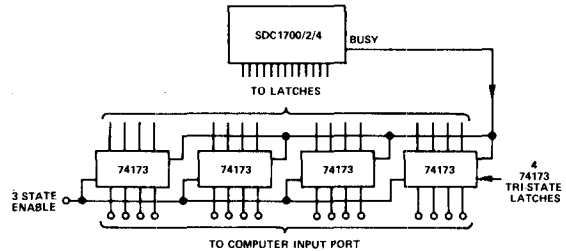

Suggested External Computer Interface Circuitry

### THEORY OF OPERATION

If the unit is a Synchro-to-Digital Converter, then the 3 wire synchro output will be connected to S1, S2 and S3 on the module and the Scott T transformer pair will convert these signals into resolver format.

$$\begin{aligned} \text{i.e., } V_1 &= K E_0 \sin \omega t \sin \theta \\ V_2 &= K E_0 \sin \omega t \cos \theta \end{aligned}$$

Where  $\theta$  is the angle of the Synchro Shaft.

If the unit is a Resolver-to-Digital Converter, then the 4 wire resolver output will be connected to S1, S2, S3 and S4 on the module and the microtransformer will act purely as an isolator.

To understand the conversion process, then assume that the current word state of the up-down counter is  $\phi$ .

The  $V_1$  is multiplied by  $\cos \phi$  and  $V_2$  is multiplied by  $\sin \phi$  to give

$$\begin{aligned} &K E_0 \sin \omega t \sin \theta \cos \phi \\ \text{and } &K E_0 \sin \omega t \cos \theta \sin \phi \end{aligned}$$

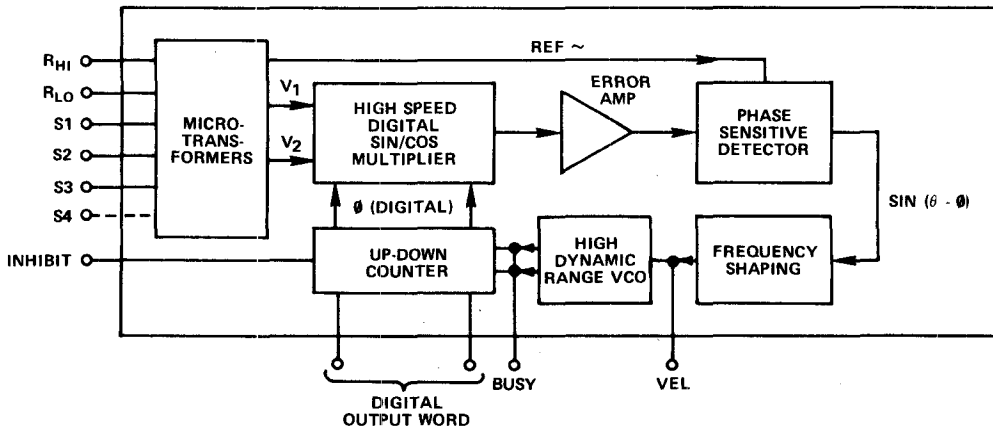

Functional Diagram of the SDC1700/2/4 Converters

These signals are subtracted by the error amplifier to give:

$$K E_O \sin \omega t (\sin \theta \cos \phi - \cos \theta \sin \phi)$$

or  $K E_O \sin \omega t \sin (\theta - \phi)$

A phase sensitive detector, integrator and Voltage Controlled Oscillator (VCO) form a closed loop system which seeks to null  $\sin (\theta - \phi)$ .

When this is accomplished, the word state of the up-down counter ( $\phi$ ), equals within the rated accuracy of the converter, the synchro shaft angle  $\theta$ .

### CONNECTING THE CONVERTER

The electrical connections to the converter are straightforward. The power lines, which must not be reversed, are  $\pm 15V$  and  $5V$ . They must be connected to the " $\pm 15V$ " and " $5V$ " pins with the common connection to the ground pin GND.

It is suggested that  $0.1\mu F$  and  $6.8\mu F$  capacitors be placed in parallel from  $+15V$  to GND, from  $-15V$  to GND and from  $+5V$  to GND.

The digital output is taken from pins:

- 1 through to 10 for the SDC1702
- 1 through to 12 for the SDC1700
- 1 through to 14 for the SDC1704

Pin 1 represents the MSB in each case. The reference connections are made to pins " $R_{HI}$ " and " $R_{LO}$ ".

In the case of a Synchro, the signals are connected to " $S1$ ", " $S2$ " and " $S3$ " according to the following convention:

$$E_{S1} - S3 = E_{RLO} - R_{HI} \sin \omega t \sin \theta$$

$$E_{S3} - S2 = E_{RLO} - R_{HI} \sin \omega t \sin (\theta + 120^\circ)$$

$$E_{S2} - S1 = E_{RLO} - R_{HI} \sin \omega t \sin (\theta + 240^\circ)$$

For a resolver, the signals are connected to " $S1$ ", " $S2$ ", " $S3$ " and " $S4$ " according to the following convention:

$$E_{S1} - S3 = E_{RLO} - R_{HI} \sin \omega t \sin \theta$$

$$E_{S2} - S4 = E_{RHI} - R_{LO} \sin \omega t \cos \theta$$

The analog voltage representing velocity is available between " $VEL$ " and " $GND$ ".

The " $BUSY$ " and " $INHIBIT$ " pin (if used), should be connected as described under the heading " $Data Transfer$ ".

NOTE: If the INHIBIT pin is used (i.e., driven to 0 volts), the control loop will be opened and a finite time will be required (see spec) for the converter to recover.

### OUTLINE DIMENSIONS AND PIN CONNECTION DIAGRAM

Dimensions are shown in inches and (mm).

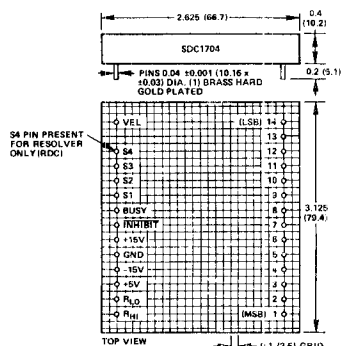

NOTE: ABOVE DIAGRAM ILLUSTRATES CONNECTIONS FOR SDC1704. FOR SDC1700, PINS 13 AND 14 ARE OMITTED. PIN 12 IS LSB. FOR SDC1702, PINS 11, 12, 13, 14 ARE OMITTED. PIN 10 IS LSB.

MATING SOCKET: CAMBION 450-3388-01-03

### RESISTIVE SCALING OF INPUTS

A unique feature of the SDC1700 series of converters is that the inputs can be resistively scaled to accommodate any range of input signal and reference voltages.

This means that a standard converter can be used with a personality card in systems where a wide range of input and reference voltages are encountered. In addition it should be noted that a 400Hz unit will operate from a 2.6kHz reference. It will however have the velocity and acceleration characteristics as specified for the 400Hz converter. A 60Hz converter will operate from a 400Hz reference and will have the velocity and acceleration characteristics as specified for the 60Hz converter.

To calculate the values of the external scaling resistors for a synchro converter, add  $1.11k\Omega$  in series with  $S1$ ,  $S2$  and  $S3$  per extra volt in the case of the signal, and  $2.2k\Omega$  in the case of the reference. In the case of a resolver converter add  $2.22k\Omega$  per extra volt in series with  $S1$  and  $S2$  for the signal and  $2.2k\Omega$  per extra volt in series with  $R_{HI}$  for the reference.

For example, assume that we have an 11.8 volt line to line signal/26.0 volt reference converter, and we wish to use a 60 volt line to line signal with a 115 volt reference.

Thus in each signal input line, the extra voltage capability required is:

$$60 - 11.8 = 48.2 \text{ volts}$$

Therefore each resistor needs to have a value of  $48.2 \times 1.11 = 53.5k\Omega$ . In the case of the reference, the extra voltage capability required is:

$$115 - 26.0 = 89 \text{ volts}$$

Therefore the resistor needs to have a value of:

$$89.0 \times 2.2 = 195.8k\Omega$$

Thus the inputs can be scaled as in the diagram below.

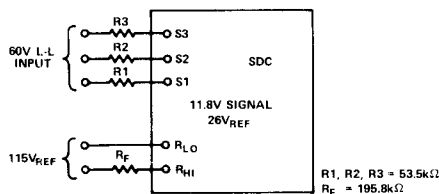

NOTE: IN THE CASE OF  $R1$ ,  $R2$  AND  $R3$ , THE RATIO ERRORS BETWEEN THE RESISTANCES IS MORE IMPORTANT THAN THE ABSOLUTE RESISTANCE VALUES.

IN GENERAL A 1% RATIO ERROR WILL GIVE RISE TO AN EXTRA INACCURACY OF 17 ARC-MINUTES WHILE A RATIO ERROR OF 0.1% WILL GIVE RISE TO AN EXTRA INACCURACY OF 1.7 ARC-MINUTES.

THE ABSOLUTE VALUE OF  $R_{HI}$  IS NOT CRITICAL.

### BIT WEIGHT TABLE

| Bit Number           | Weight in Degrees |
|----------------------|-------------------|
| 1 (MSB)              | 180.0000          |
| 2                    | 90.0000           |
| 3                    | 45.0000           |
| 4                    | 22.5000           |
| 5                    | 11.2500           |
| 6                    | 5.6250            |
| 7                    | 2.8125            |
| 8                    | 1.4063            |
| 9                    | 0.7031            |
| 10 (LSB for SDC1702) | 0.3516            |
| 11                   | 0.1758            |
| 12 (LSB for SDC1700) | 0.0879            |
| 13                   | 0.0439            |
| 14 (LSB for SDC1704) | 0.0220            |

## VELOCITY PIN

This pin provides a voltage output which is proportional to the angular velocity of the input. The voltage goes negative for an increasing digital angle and goes positive for a decreasing digital angle.

The characteristics of the velocity pin output are given in the table below.

|  |  |
|--|--|
| Scaling of Output Voltage for One Fifth max Velocity | 2Volts (Nominal)   |
| Output Voltage Temp. Coeff.                          | 0.05%/°C of Output   |
| Output Voltage Drift (All Models)                    | 0 to +70°C<br>±50µV/°C<br>-5°C to +105°C<br>±100µV/°C  |
| Linearity:   | 0/sec to 800/sec SDC1704<br>400Hz 1%<br>0/sec to 100/sec SDC1704<br>60Hz 1%<br>0/sec to 800/sec SDC1700/2<br>400Hz 2%<br>0/sec to 100/sec SDC1700/2<br>50Hz 1.5% |
| Noise: (0 to 20Hz)                                   | @1500/sec SDC1700/2/4<br>400Hz 2mV rms<br>@200/sec SDC1700/2/4<br>50Hz 2mV rms   |
| Impedance (Output)                                   | 1Ω   |
| max Current Available                                | 1mA  |

The velocity voltage can be used in closed loop servo systems for stabilization instead of a tachometer.

The SDC1700/2/4 velocity outputs do not have the disadvantages of being inefficient at low speeds and do not need gearing required by tachometers. In addition, the output is available at no extra cost.

For other velocity output scaling and linearity consult the factory.

Two examples of the use of the velocity pin are shown in the diagram below.

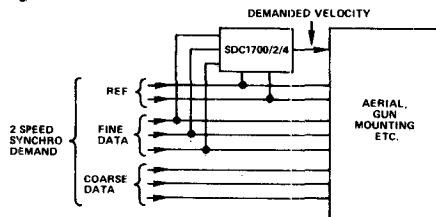

Diagram showing a velocity feed forward application. The SDC is used to produce the demanded velocity from Synchro form inputs.

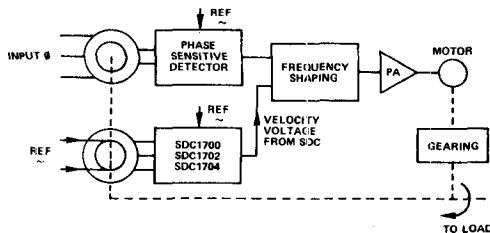
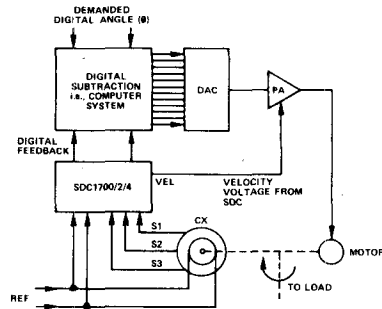

Diagram showing the velocity voltage being used to stabilize an electro-mechanical control loop

## APPLICATIONS OF SYNCHRO-TO-DIGITAL CONVERTERS

SDCs can be used in a variety of ways in control loops as well as for the conversion of angular data into a form which is readily acceptable to digital displays or computers.

The diagram below shows an SDC being used in a digitally controlled feedback loop.



An SDC Being Used in a Digitally Controlled Feedback Loop

Such loops as shown in the diagram above require the high dynamic performance of the SDC1700 series converters. It should be noted that in this application, the SDC1700 series will replace conventional tachometers and phase sensitive detectors while at the same time provide digital position feedback.

Many synchro systems employ a two speed, geared arrangement utilizing one synchro for the fine shaft and one for the coarse. An example of this type is shown below.

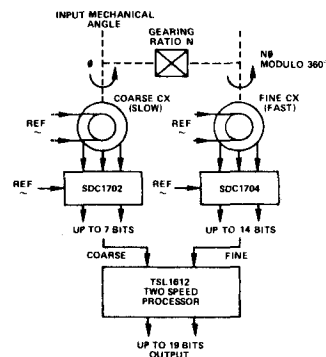

Diagram Showing Coarse/Fine Synchro Processor System

In the above example, two tracking SDC's are being used to provide data for coarse/fine (two speed) data transmission systems.

The TSL1612 is a processor which combines the outputs of two SDC's to provide one output word of up to 19 bits in length.

The TSL1612 is available for any ratio between 2:1 and 36:1 and provides automatic compensation for misalignment of the coarse synchro relative to its shaft. It also corrects for any overlap between the digits of the coarse and fine shafts.

### MEAN TIME BETWEEN FAILURES (M.T.B.F.)

The estimated mean time between failures is given as follows:

|           |               |
|-----------|---------------|
| SDC1700/2 | 174,000 Hours |
| SDC1704   | 167,000 Hours |

Further information relating to M.T.B.F. and to the quality control and test procedures employed by us can be obtained from the factory on request.

### TRANSFER FUNCTION

The transfer function of the SDC1700/2 and SDC1704, 400Hz versions, is given below.

For the transfer functions of the other models or for a detailed analysis of those given here, please contact us.

#### SDC1700/2 400Hz

$$\frac{\theta_0}{\theta_1} = \frac{8.8 \times 10^7 (1 + 6.8 \times 10^{-3} s)}{s^3 + 8.04 \times 10^2 s^2 + 6.1 \times 10^5 s + 8.8 \times 10^7}$$

#### SDC1704 400Hz

$$\frac{\theta_0}{\theta_1} = \frac{2.95 \times 10^7 (1 + 8.2 \times 10^{-3} s)}{s^3 + 8.05 \times 10^2 s^2 + 1.95 \times 10^5 s + 2.95 \times 10^7}$$

### CARD MOUNTING

All the converters can be mounted on an AC1755 mounting card. This card contains the latches described under the "Data Transfer" heading, which are necessary to transfer the data on to a computer bus system, and sockets for the converter.

The latches have a tri-state output to facilitate ease of use.

The AC1755 also contains facilities for the inclusion of input signal and reference scaling resistors as described under the heading "Resistive Scaling of Inputs".

The card uses a 22/22 0.156" pitch edge connector. The pin out is shown below. If it is not required to use the external latches, they can be jumpered on the board.

**AC1755 MOUNTING CARD**  
Dimensions shown in inches and (mm).

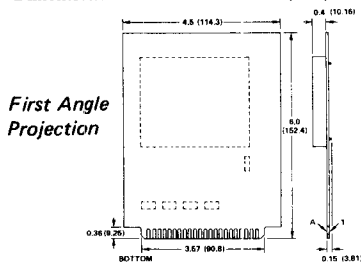

### EDGE CONNECTIONS AC1755

| Edge Pin Number | Function | Edge Pin Letter | Function         |
|-----------------|----------|-----------------|------------------|
| 1               | R (Lo)   | A               | Tri-State Enable |
| 2               | R (Hi)   | F               | +15V             |
| 3               | S3       | H               | +15V             |
| 4               | S2       | J               | -15V             |
| 5               | S1       | K               | -15V             |
| 6               | S4       | L               | GND              |
| 8               | VEL      | M               | GND              |
| 13              | BUSY     | N               | +5V              |
| 15              | INHIBIT  | P               | +5V              |
| 16              | BIT 14   | T               | BIT 7            |
| 17              | BIT 13   | U               | BIT 6            |
| 18              | BIT 12   | V               | BIT 5            |
| 19              | BIT 11   | W               | BIT 4            |
| 20              | BIT 10   | X               | BIT 3            |
| 21              | BIT 9    | Y               | BIT 2            |
| 22              | BIT 8    | Z               | BIT 1            |

NOTE: SDC1702 does not use pins 16, 17, 18 or 19. SDC1700 does not use pins 16 and 17.

### ORDERING INFORMATION

Parts should be ordered by the appropriate part number (i.e.,

SDC1700, SDC1702, SDC1704) followed by the appropriate XYZ option code.

If the unit is to be a Resolver-to-Digital Converter, the SDC should be replaced by RDC in the part number.

The XYZ options are as follows:

X signifies the operating temperature range and the options are:

- X = 5 signifies 0 to +70°C (commercial) temperature.
- X = 6 signifies -55°C to +105°C (extended) temperature.

Y signifies the reference frequency and the options are:

- Y = 1 signifies 400Hz
- Y = 2 signifies 60Hz\*
- Y = 4 signifies 2.6kHz

Z signifies the input signal and reference voltages and whether the converter is an SDC or an RDC. The options are:

- Z = 1 signifies synchro, signal 11.8V rms, reference 26V rms
- Z = 2 signifies synchro, signal 90V rms, reference 115V rms
- Z = 3 signifies resolver, signal 11.8V rms, reference 11.8V rms
- Z = 4 signifies resolver, signal 26V rms, reference 26V rms
- Z = 8 signifies resolver, signal 11.8V rms, reference 26V rms

Thus, for example, an SDC1704 with a commercial (0 to +70°C) operating range, using a 400Hz, 26V reference with an 11.8V signal would be ordered as an SDC1704511.

For other than these options, consult the factory.

### CAUTIONS

Do not reverse the power supplies.

Do not connect signal and/or reference inputs to other than S1, S2, S3, S4, R<sub>HI</sub> or R<sub>LO</sub>.

Do not connect signals and/or references to a lower voltage rated converter. (Such as a 115V Synchro into a 26V Converter).

Misconnections as per the above will damage the units and void the warranty.

### OTHER PRODUCTS

The SDC1700/2/4 converters are just a few of the modules and instruments concerned with Synchro and Resolver conversion manufactured by us.

Other products are listed below and technical data is available. If you have any questions about our products, or require advice about the use of them for a particular application, please contact our Applications Engineering Department.

### TWO SPEED PROCESSORS

Which utilize the digital outputs of two SDCs in a 2 speed coarse/fine system to produce one combined digital word of up to 19 bits in length. The TSL1612 in particular is available for any ratio between 2:1 and 36:1.

### DIGITAL-TO-SYNCHRO CONVERTERS

Resolutions of between 10 and 14 bits are available.

### BCD OUTPUT SYNCHRO-TO-DIGITAL CONVERTERS

The SBCD1752 and SBCD1753 are converters with a BCD instead of a binary output based upon the SDC1700. They have outputs of ±180.0 degrees and 0 to 360.0 degrees respectively.

### \*50Hz Operation

For 50Hz operation, a 60Hz converter can be used with no reduction in accuracy.