

# Service Manual

*General Description*

*Adjustment Procedures*

*Block / Schematic Diagrams*

*Exploded Views / Parts List*

Video Cassette Recorder

**Panasonic** **VHS**  
PAL NTSC

**Hi-Fi HQ**

**NV-HD650<sup>EE/AM</sup><sub>BD</sub>**

**NV-HD655AM**

**K-MECHANISM**

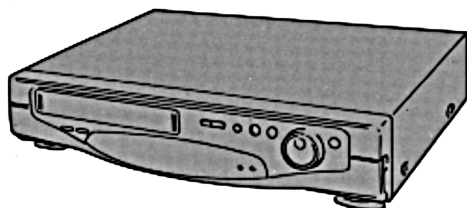

**SPECIFICATIONS / ТЕХНИЧЕСКИЕ ХАРАКТЕРИСТИКИ  
ОБЩИЕ ОПИСАНИЯ**

СЕРВИСНАЯ ИНФОРМАЦИЯ  
ИНДИКАЦИОННЫЙ ДИСПЛЕЙ САМОТЕСТИРОВАНИЯ  
ДИСПЛЕЙ СЕРВИСНОЙ ИНФОРМАЦИИ

**МЕТОДИКА РЕГУЛИРОВКИ**

МЕТОД РАЗБОРКИ  
МЕТОДИКА МЕХАНИЧЕСКОЙ РЕГУЛИРОВКИ  
МЕТОДИКА РАЗБОРКИ МЕХАНИЗМА  
МЕТОДИКА СБОРКИ МЕХАНИЗМА  
МЕТОДИКА ЭЛЕКТРИЧЕСКОЙ РЕГУЛИРОВКИ

**BLOCK DIAGRAMS / БЛОК-СХЕМЫ**

NICAM DECODER BLOCK DIAGRAM / БЛОК-СХЕМА МОДУЛЯ ДЕКОДИРОВАНИЯ NICAM-СИГНАЛА  
SYSTEM CONTROL & SERVO BLOCK DIAGRAM / БЛОК-СХЕМА СИСТЕМЫ УПРАВЛЕНИЯ И СЕРВОПРИВОДА  
LUMINANCE & CHROMINANCE BLOCK DIAGRAM (NV-HD650EE) / БЛОК-СХЕМА КАНАЛОВ ЯРКОСТИ И ЦВЕТА (NV-HD650EE)  
LUMINANCE & CHROMINANCE BLOCK DIAGRAM (NV-HD650AM/BD, NV-HD655AM) / БЛОК-СХЕМА КАНАЛОВ ЯРКОСТИ И ЦВЕТА (NV-HD650AM/BD, NV-HD655AM)  
Hi-Fi AUDIO BLOCK DIAGRAM (NV-HD650EE) / БЛОК-СХЕМА ОБРАБОТКИ АУДИО-СИГНАЛА (NV-HD650EE)  
Hi-Fi AUDIO BLOCK DIAGRAM (NV-HD650AM/BD, NV-HD655AM) / БЛОК-СХЕМА ОБРАБОТКИ АУДИО-СИГНАЛА (NV-HD650AM/BD, NV-HD655AM)

**SCHEMATIC DIAGRAMS / ПРИНЦИПИАЛЬНЫЕ СХЕМЫ**

POWER SUPPLY SECTION IN MAIN SCHEMATIC DIAGRAM (NV-HD650EE) / ПРИНЦИПИАЛЬНАЯ СХЕМА (ОСНОВНАЯ) БЛОКА ПИТАНИЯ (NV-HD650EE)  
POWER SUPPLY SECTION IN MAIN SCHEMATIC DIAGRAM (NV-HD650AM/BD, NV-HD655AM) / ПРИНЦИПИАЛЬНАЯ СХЕМА (ОСНОВНАЯ) БЛОКА ПИТАНИЯ (NV-HD650AM/BD, NV-HD655AM)  
LUMINANCE/CHROMINANCE & AUDIO SECTION IN MAIN SCHEMATIC DIAGRAM (NV-HD650EE) / ПРИНЦИПИАЛЬНАЯ СХЕМА (ОСНОВНАЯ) КАНАЛОВ ЯРКОСТИ И ЦВЕТА И ОБРАБОТКИ АУДИОСИГНАЛА (NV-HD650EE)  
LUMINANCE/CHROMINANCE & AUDIO SECTION IN MAIN SCHEMATIC DIAGRAM (NV-HD650AM/BD, NV-HD655AM) / ПРИНЦИПИАЛЬНАЯ СХЕМА (ОСНОВНАЯ) КАНАЛОВ ЯРКОСТИ И ЦВЕТА И ОБРАБОТКИ АУДИОСИГНАЛА (NV-HD650AM/BD, NV-HD655AM)  
RF SECTION IN MAIN SCHEMATIC DIAGRAM / ПРИНЦИПИАЛЬНАЯ СХЕМА (ОСНОВНАЯ) ВЫСОКОЧАСТОТНОГО БЛОКА  
SYSTEM CONTROL & SERVO SECTION IN MAIN SCHEMATIC DIAGRAM / ПРИНЦИПИАЛЬНАЯ СХЕМА (ОСНОВНАЯ) СИСТЕМЫ УПРАВЛЕНИЯ И СЕРВОПРИВОДА  
MOTOR DRIVE & SUB AUDIO PACK SCHEMATIC DIAGRAM / ПРИНЦИПИАЛЬНАЯ СХЕМА ПРИВОДА ЭЛЕКТРОДВИГАТЕЛЯ И ОБРАБОТКИ АУДИОСИГНАЛА (ДОПОЛНИТЕЛЬНАЯ)  
Hi-Fi AUDIO PACK SCHEMATIC DIAGRAM / ПРИНЦИПИАЛЬНАЯ СХЕМА ОБРАБОТКИ АУДИОСИГНАЛА  
OSD PACK SCHEMATIC DIAGRAM (NV-HD650EE) / ПРИНЦИПИАЛЬНАЯ СХЕМА БЛОКА ЭКРАННЫХ МЕНЮ (NV-HD650EE)  
INPUT/OUTPUT PACK SCHEMATIC DIAGRAM (NV-HD650EE) / ПРИНЦИПИАЛЬНАЯ СХЕМА ПЛАТЫ ВВОДА-ВЫВОДА (NV-HD650EE)  
INPUT/OUTPUT PACK SCHEMATIC DIAGRAM (NV-HD650AM/BD, NV-HD655AM) / ПРИНЦИПИАЛЬНАЯ СХЕМА ПЛАТЫ ВВОДА-ВЫВОДА (NV-HD650AM/BD, NV-HD655AM)  
HEAD AMP SCHEMATIC DIAGRAM / ПРИНЦИПИАЛЬНАЯ СХЕМА УСИЛИТЕЛЯ ВИДЕОГОЛОВКИ  
LUMINANCE & CHROMINANCE PACK SCHEMATIC DIAGRAM / ПРИНЦИПИАЛЬНАЯ СХЕМА КАНАЛОВ ЯРКОСТИ И ЦВЕТА (ДОПОЛНИТЕЛЬНАЯ)  
TIMER & OPERATION SCHEMATIC DIAGRAM (NV-HD650EE) / ПРИНЦИПИАЛЬНАЯ СХЕМА ПЛАТЫ УПРАВЛЕНИЯ И ТАЙМЕРА (NV-HD650EE)  
TIMER & OPERATION SCHEMATIC DIAGRAM (NV-HD650AM/BD, NV-HD655AM) / ПРИНЦИПИАЛЬНАЯ СХЕМА ПЛАТЫ УПРАВЛЕНИЯ И ТАЙМЕРА (NV-HD650AM/BD, NV-HD655AM)  
TV DEMODULATOR PACK SCHEMATIC DIAGRAM (NV-HD650BD) / ПРИНЦИПИАЛЬНАЯ СХЕМА TV ДЕМОДУЛЯТОРА (NV-HD650BD)  
TV DEMODULATOR PACK SCHEMATIC DIAGRAM (NV-HD650AM/EE, NV-HD655AM) / ПРИНЦИПИАЛЬНАЯ СХЕМА TV ДЕМОДУЛЯТОРА (NV-HD650AM/EE, NV-HD655AM)  
NICAM DECODER PACK SCHEMATIC DIAGRAM (NV-HD650BD, NV-HD655AM) / ПРИНЦИПИАЛЬНАЯ СХЕМА ПЛАТЫ ДЕКОДИРОВАНИЯ NICAM-СИГНАЛА (NV-HD650BD, NV-HD655AM)  
DECODER PACK SCHEMATIC DIAGRAM (NV-HD650AM/EE) / ПРИНЦИПИАЛЬНАЯ СХЕМА ПЛАТЫ ДЕКОДИРОВАНИЯ NICAM-СИГНАЛА (NV-HD650AM/EE)

**EXPLODED VIEWS & PARTS LIST / СБОРОЧНЫЕ ЧЕРТЕЖИ И СПИСОК ЗАПАСНЫХ ЧАСТЕЙ**

EXPLODED VIEW & MECHANICAL REPLACEMENT PARTS LIST / СБОРОЧНЫЕ ЧЕРТЕЖИ И СПИСОК МЕХАНИЧЕСКИХ ЗАПАСНЫХ ЧАСТЕЙ  
CHASSIS PARTS SECTION (1) / ШАССИ (СЕКЦИЯ 1)  
CHASSIS PARTS SECTION (2) / ШАССИ (СЕКЦИЯ 2)  
CASING PARTS SECTION / КОРПУС  
PACKING PARTS SECTION / УПАКОВКА  
REMOTE CONTROLLER UNIT / ПУЛЬТ ДИСТАНЦИОННОГО УПРАВЛЕНИЯ  
ELECTRICAL REPLACEMENT PARTS LIST / СПИСОК ЭЛЕКТРИЧЕСКИХ ЗАПАСНЫХ ЧАСТЕЙ

**Panasonic**

© 1995 Matsushita Electric Industrial Co., Ltd.  
All rights reserved. Unauthorized copying and distribution is a violation of law.

# SECTION 4 SCHEMATIC DIAGRAMS

## 4-1. POWER SUPPLY SECTION IN MAIN SCHEMATIC DIAGRAM (NV-HD650)

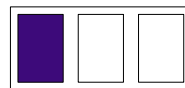
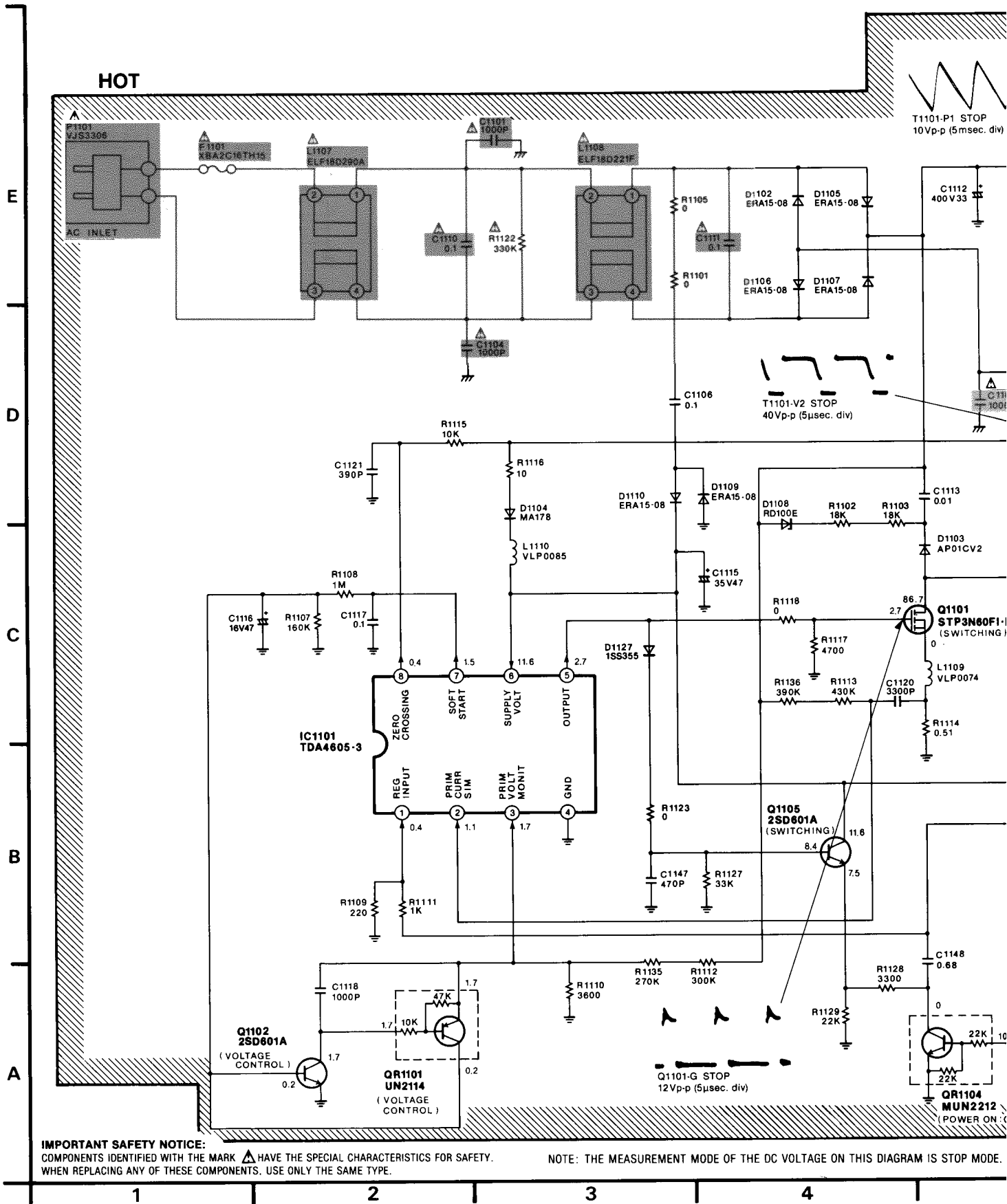

# D650EE)

## CAUTION

THE RED MARK INDICATES THE PRIMARY CIRCUIT TO DISTINGUISH THE SECONDARY CIRCUIT.  
PAY ATTENTION NOT TO RECEIVE AN ELECTRIC SHOCK DURING REPAIR OF THE PRODUCTS.

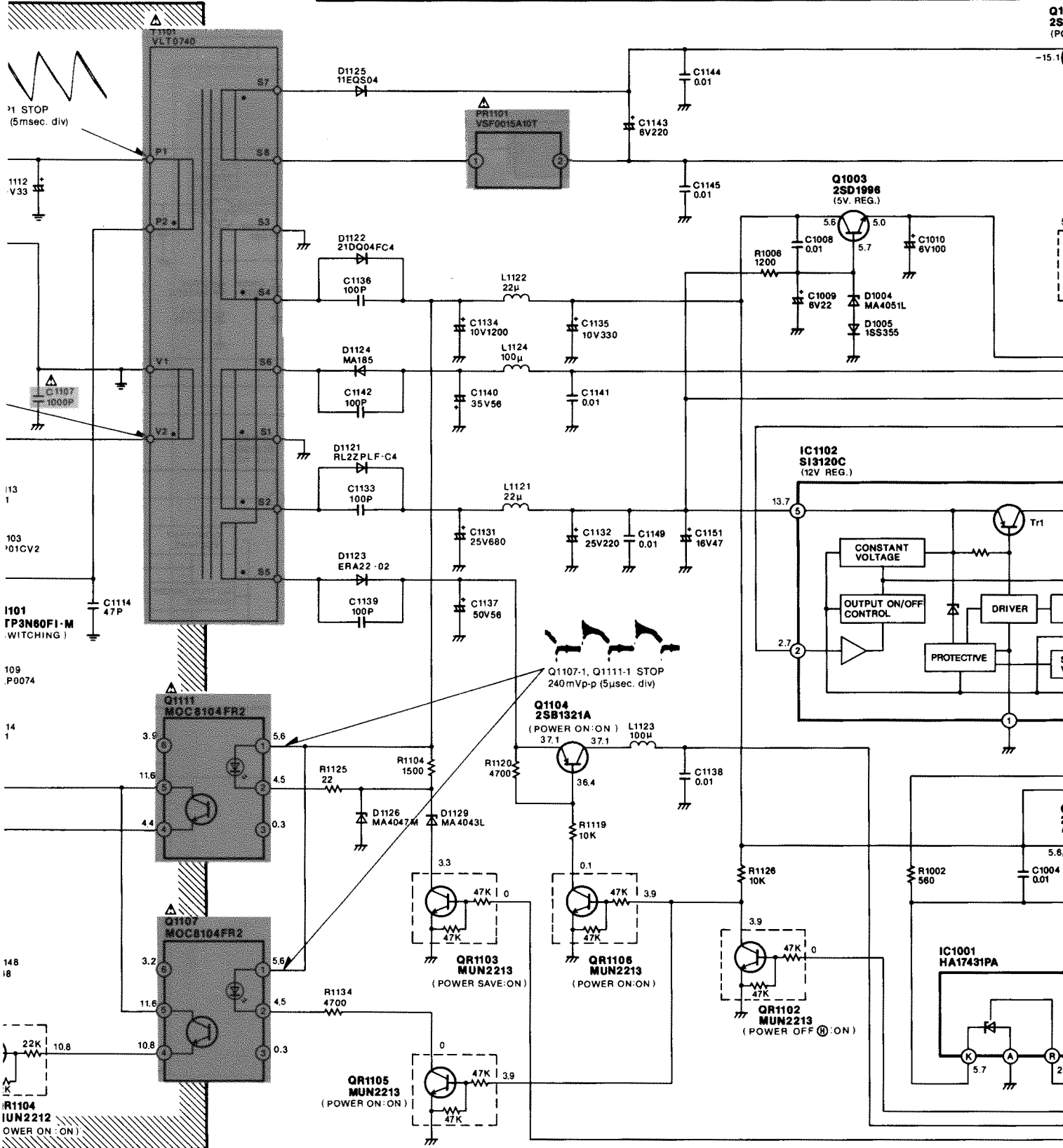

NOTE 1. WHEN MEASURE THE VOLTAGE OR WAVEFORM ON THE POWER TRANSFORMER PRIMARY SIDE . . . . . ⚡  
SECONDARY SIDE . . . . . ⚡

NOTE 2. THE DC VOLTAGE INPUT AC IS 240V.

TOP MODE. 5 6 7 8 9

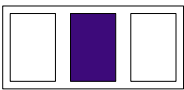

DISTINGUISH THE PRIMARY FROM  
DURING REPAIR AND SERVICE OF

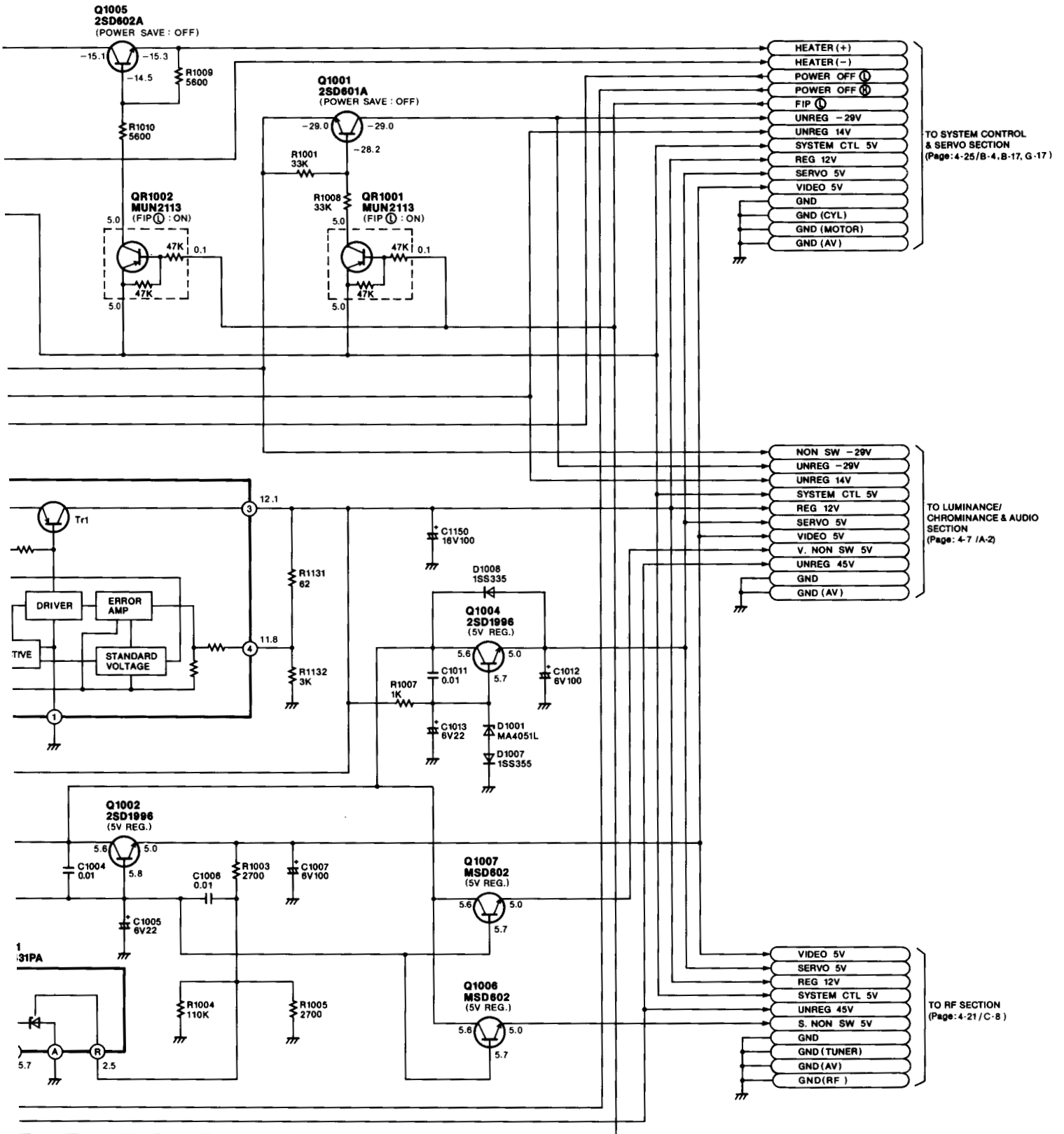

DC VOLTAGE INDICATED IN PRIMARY SIDE IS SHOWN THE VOLTAGE WHEN IT AC IS 240V.

NOTE: DO NOT USE ANY PART NUMBER SHOWN ON THIS SCHEMATIC DIAGRAM FOR ORDERING. WHEN YOU ORDER A PART, PLEASE REFER TO PARTS LIST.

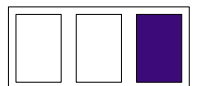



# 4-2. POWER SUPPLY SECTION IN MAIN SCHEMATIC DIAGRAM (NV-HD650A)

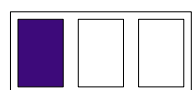
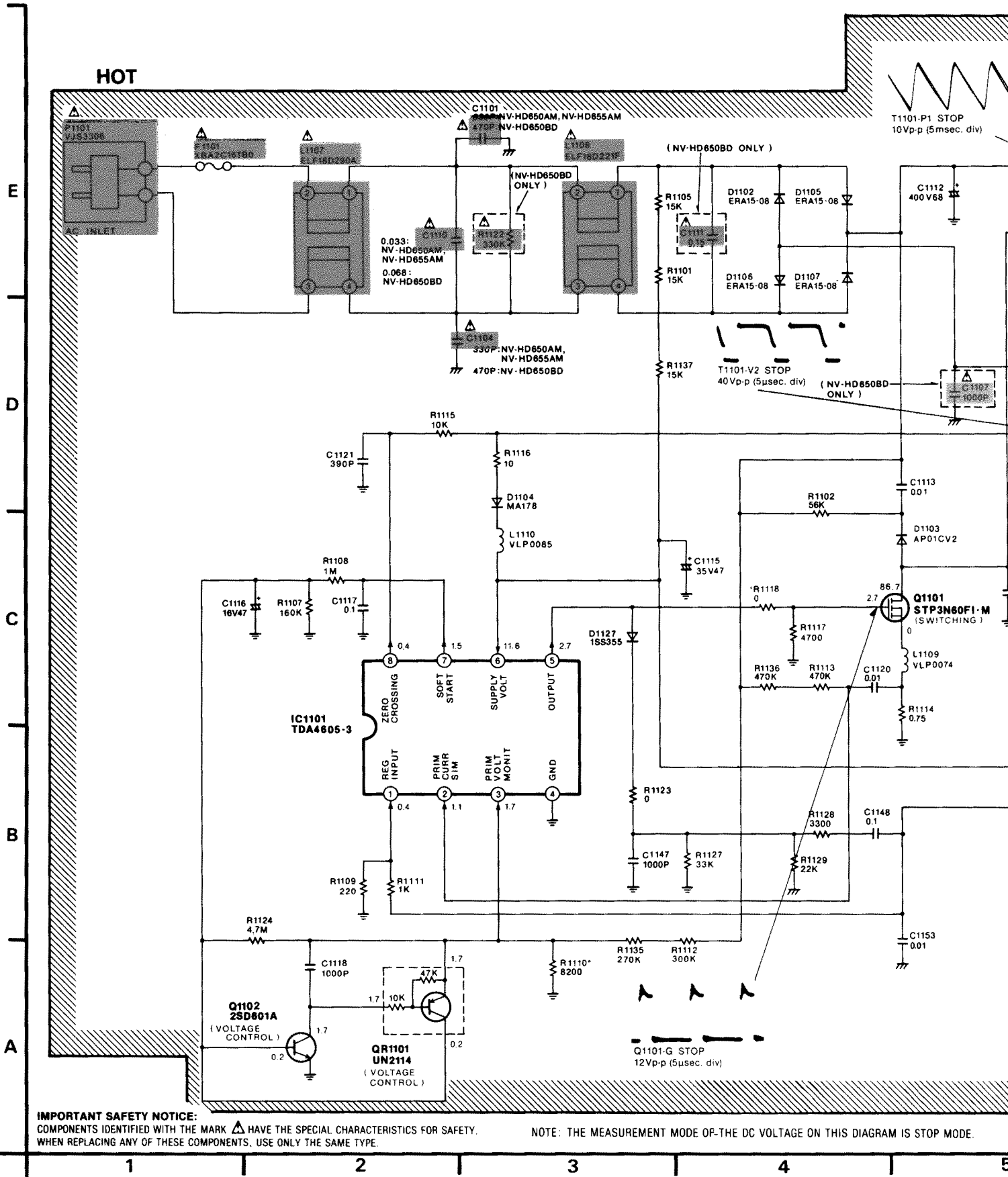

**(NV-HD650AM/BD,NV-HD655AM)**

**CAUTION** THE RED MARK INDICATES THE PRIMARY CIRCUIT TO DISTINGUISH THE SECONDARY CIRCUIT.  
 PAY ATTENTION NOT TO RECEIVE AN ELECTRIC SHOCK DURING REPAIR OF THE PRODUCTS.

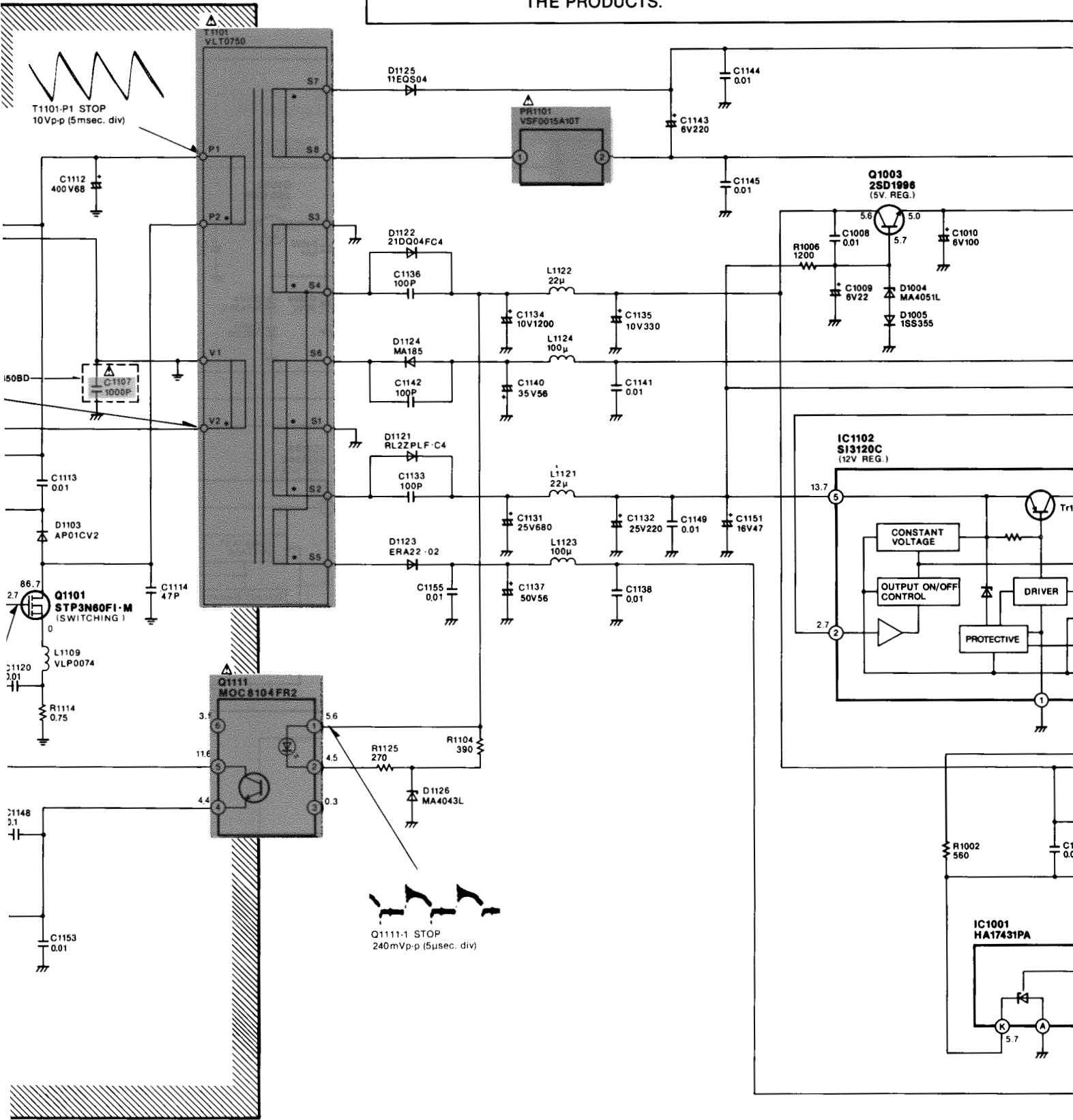

GRAM IS STOP MODE.

NOTE 1. WHEN MEASURE THE VOLTAGE OR WAVEFORM ON THE POWER TRANSFORMER CIRCUIT, SET THE GND TERMINAL OF MEASURING POINT AS FOLLOWS.

PRIMARY SIDE ..... ≍  
 SECONDARY SIDE ... ⏏

NOTE 2. THE DC VOLTAGE INPUT AC IS 240

5 | 6 | 7 | 8 | 9



DISTINGUISH THE PRIMARY FROM  
DURING REPAIR AND SERVICE OF

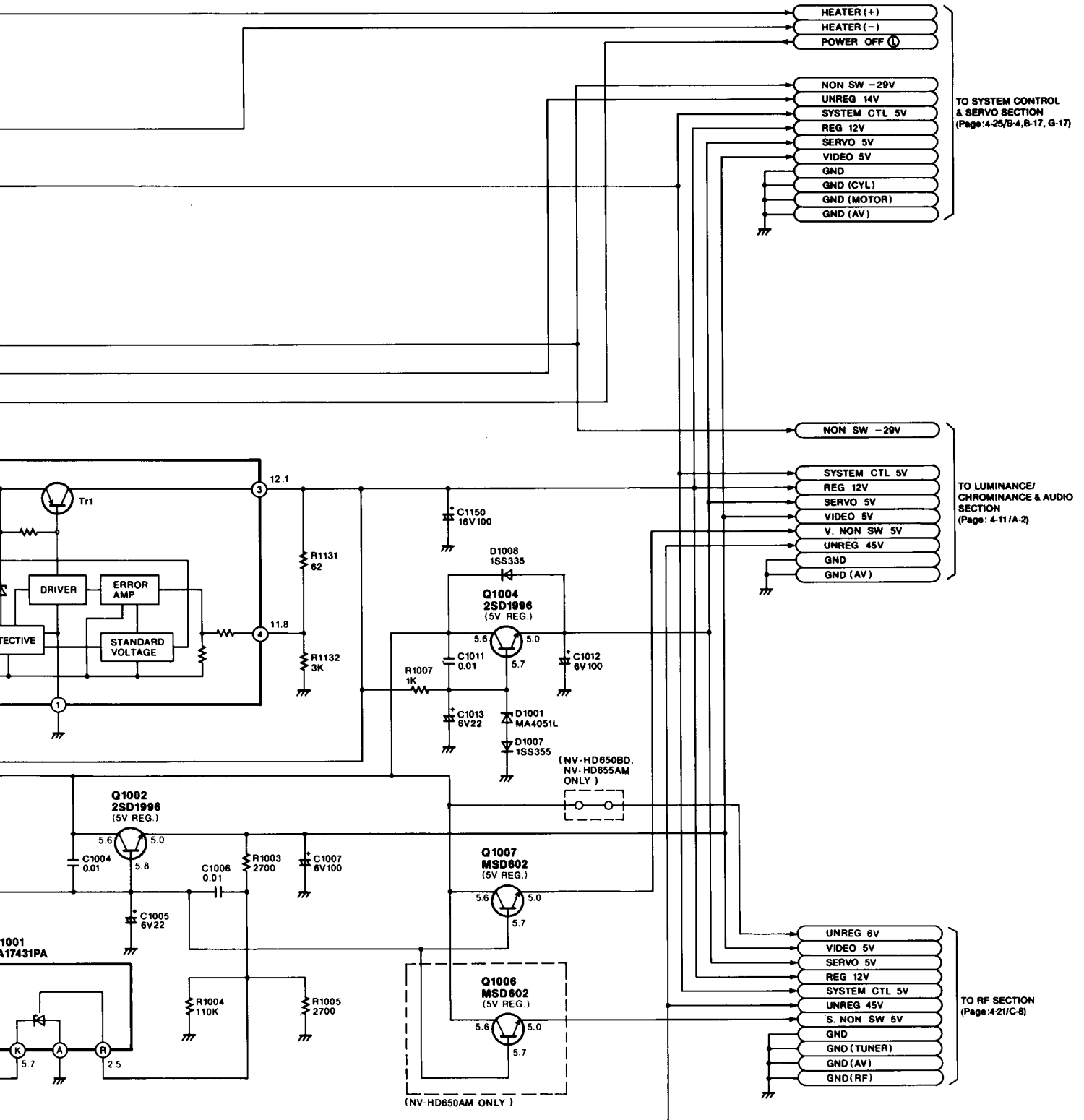

THE DC VOLTAGE INDICATED IN PRIMARY SIDE IS SHOWN THE VOLTAGE WHEN  
INPUT AC IS 240V.

NOTE: DO NOT USE ANY PART NUMBER SHOWN ON THIS  
SCHEMATIC DIAGRAM FOR ORDERING. WHEN YOU  
ORDER A PART, PLEASE REFER TO PARTS LIST.

9 | 10 | 11 | 12 | 13

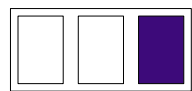

# 4-3. LUMINANCE/CHROMINANCE & AUDIO SECTION IN MAIN SCHEMATIC

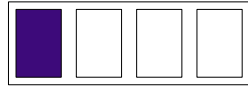
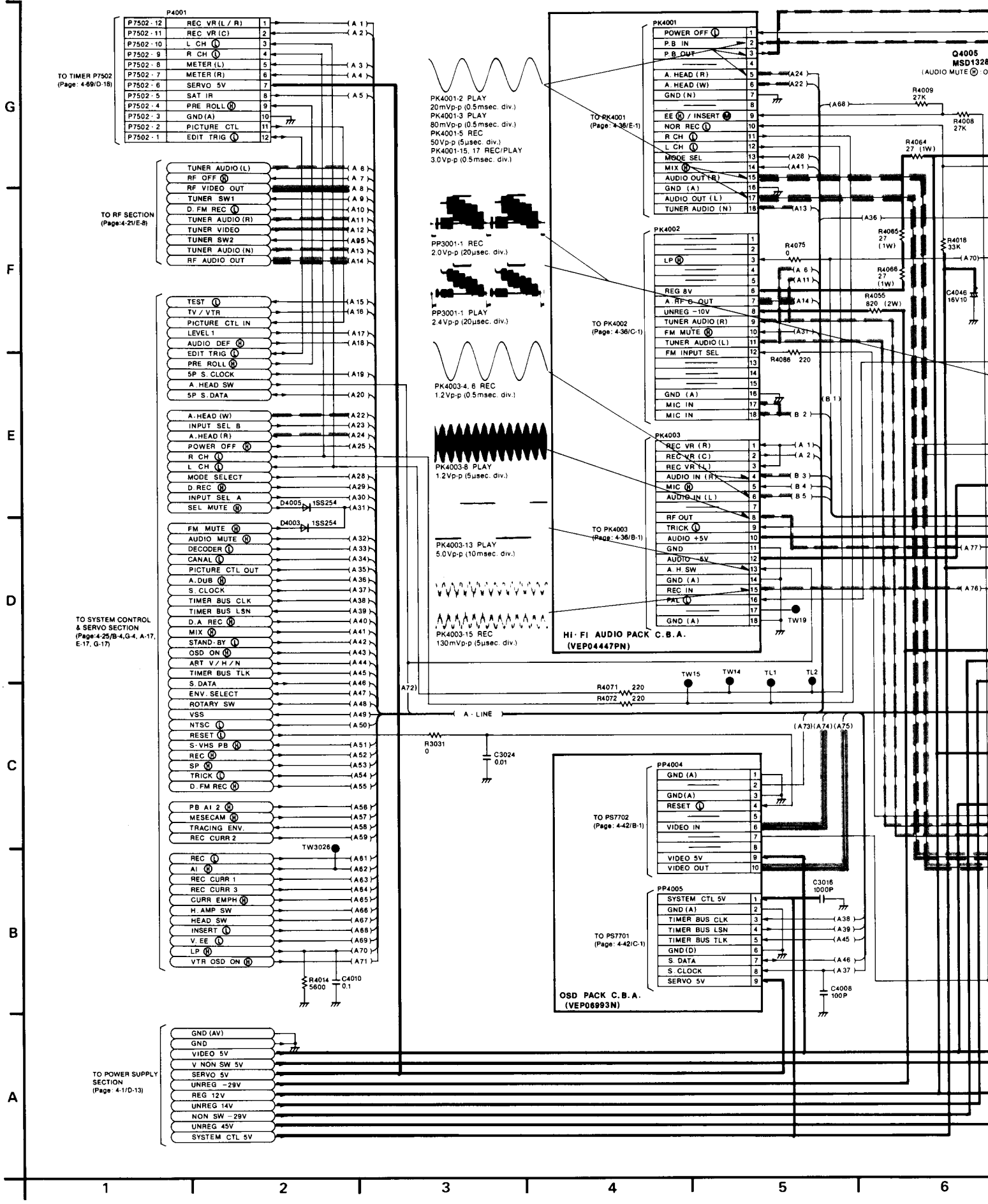



# MAIN SCHEMATIC DIAGRAM (NV-HD650EE)

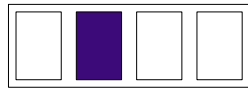
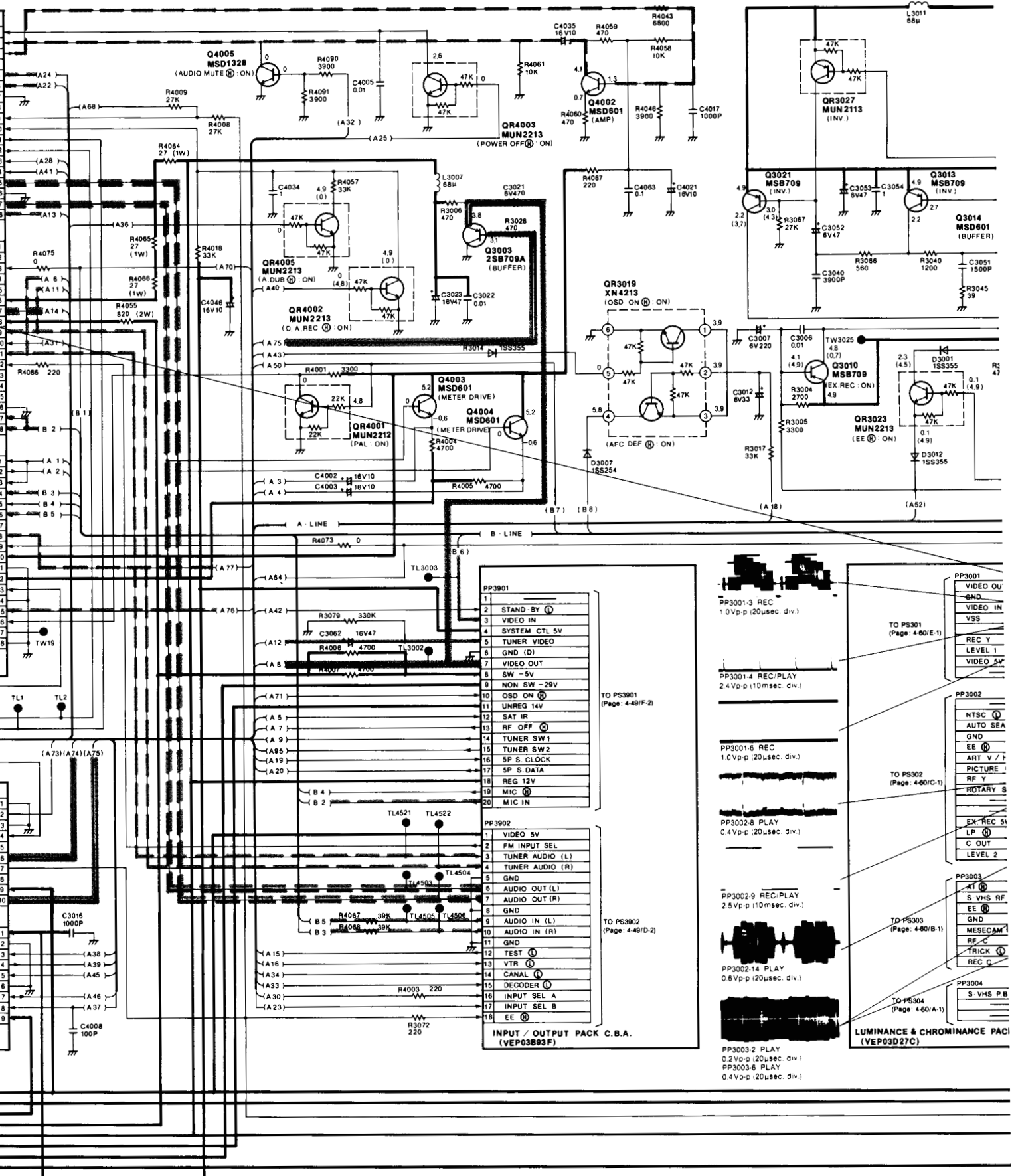

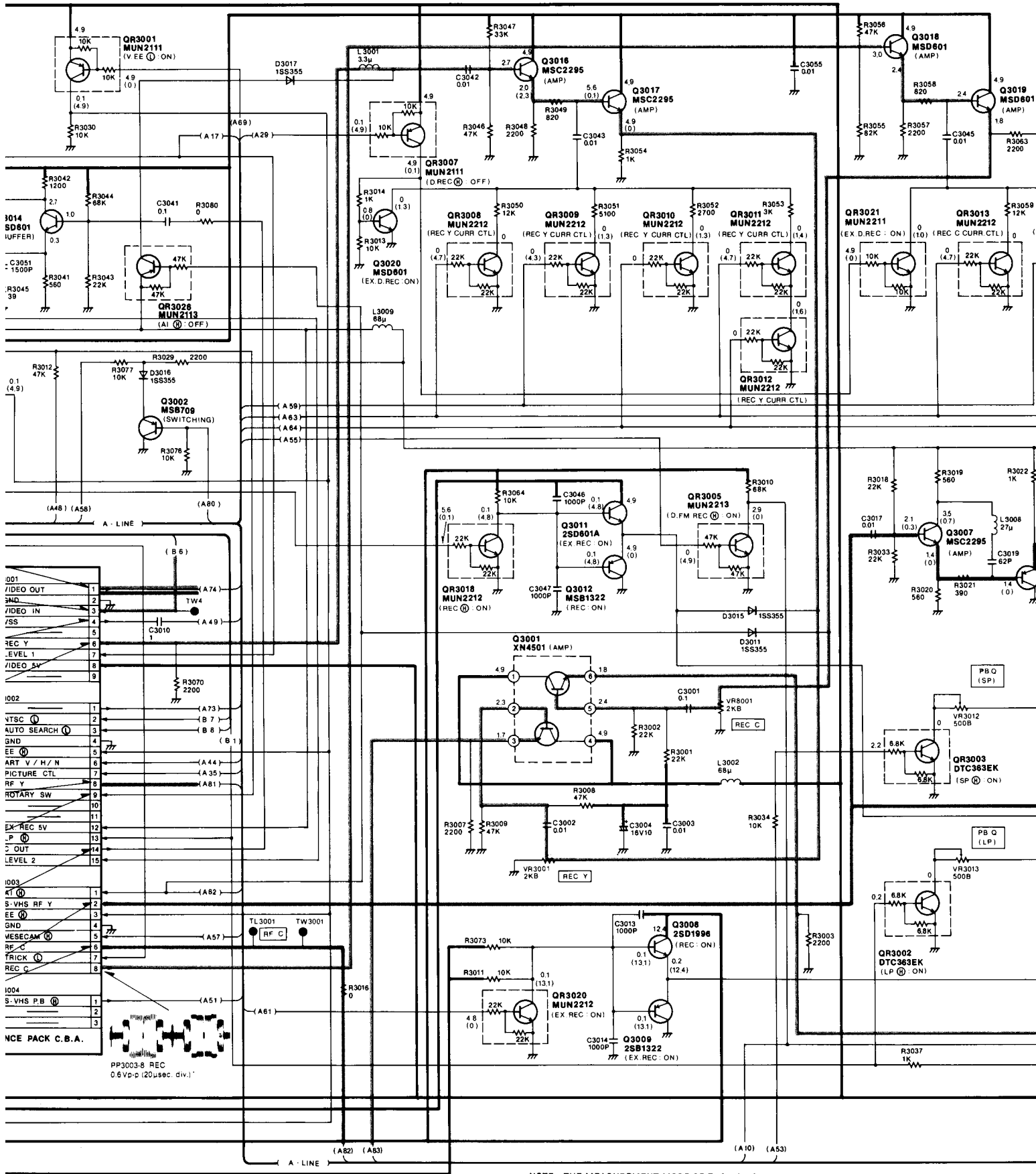

NOTE: THE MEASUREMENT MODE OF THE DC VOLTAGE IN THE BRACKETS ( ) ON THIS DIAGRAM IS RECO WITH PAL COLOUR SIGNAL. (SP MODE)  
 THE MEASUREMENT MODE OF THE DC VOLTAGE OUT OF THE BRACKETS ON THIS DIAGRAM IS PLAYBA WITH PAL COLOUR SIGNAL. (SP MODE)

11

12

13

14

15

16

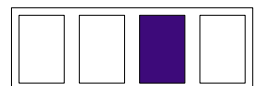

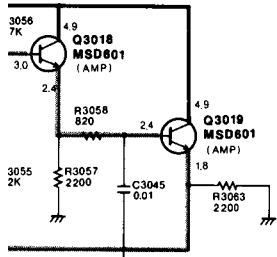

- - - - - VIDEO MAIN SIGNAL PATH IN REC MODE  
 ————— VIDEO MAIN SIGNAL PATH IN PLAYBACK MODE  
 - - - - - AUDIO MAIN SIGNAL PATH IN REC MODE  
 - - - - - AUDIO MAIN SIGNAL PATH IN PLAYBACK MODE

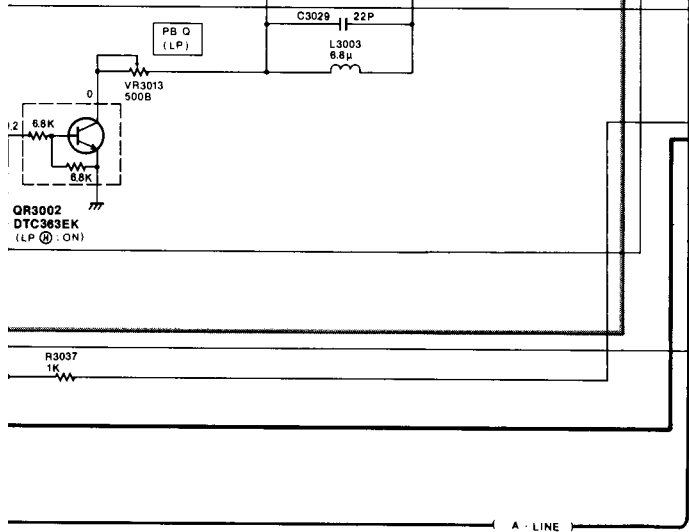
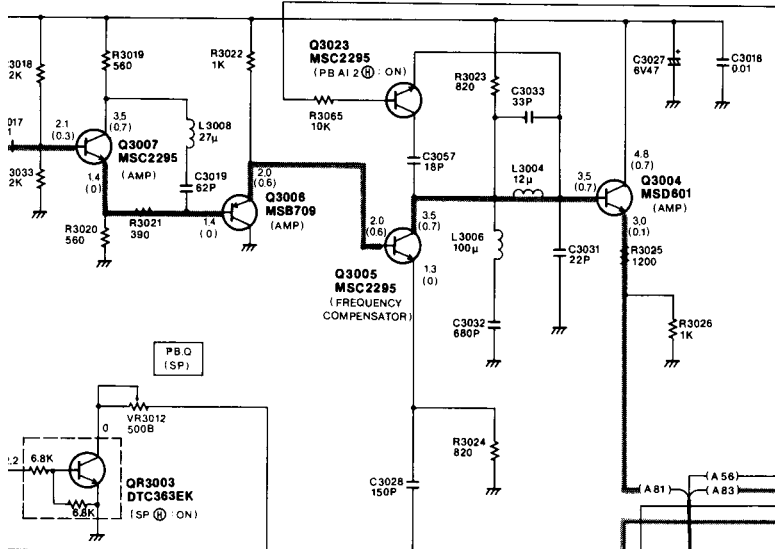
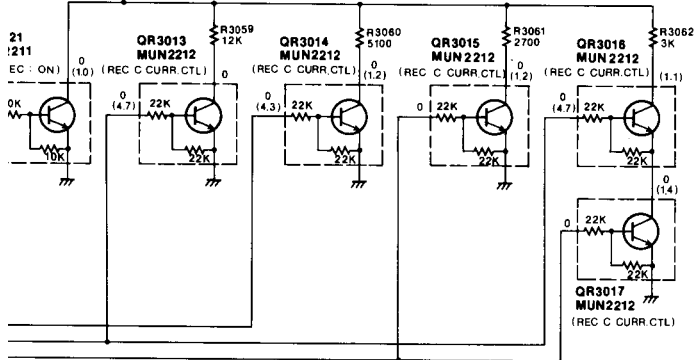

Pin	Signal	Part
20	REC Y	P501 - 1
19	REC 12V	P501 - 2
18	REC C	P501 - 3
17	GND	P501 - 4
16	RF Y	P501 - 5
15	EX. REC 5V	P501 - 6
14	RF C	P501 - 7
13	H. AMP SW	P501 - 8
12	HEAD SW	P501 - 9
11	TRACKING ENV.	P501 - 10
10	ENV. SELECT	P501 - 11
9	CURR EMPH	P501 - 12
8	LP	P501 - 13
7	VIDEO 5V	P501 - 14
6	GND	P501 - 15
5	GND	P501 - 16
4	A. HEAD SW	P501 - 17
3	REC IN	P501 - 18
2	RF OUT	P501 - 19
1	D. FM REC	P501 - 20

TO HEAD AMP P501  
(Page 4-57/E-2)

( ) ON THIS DIAGRAM IS RECORD MODE

( ) ON THIS DIAGRAM IS PLAYBACK MODE

NOTE: DO NOT USE ANY PART NUMBER SHOWN ON THIS SCHEMATIC DIAGRAM FOR ORDERING. WHEN YOU ORDER A PART, PLEASE REFER TO PARTS LIST.

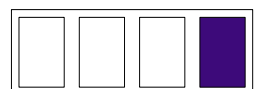

# 4-4. LUMINANCE/CHROMINANCE & AUDIO SECTION IN MAIN SCHEMATIC

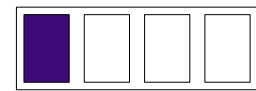
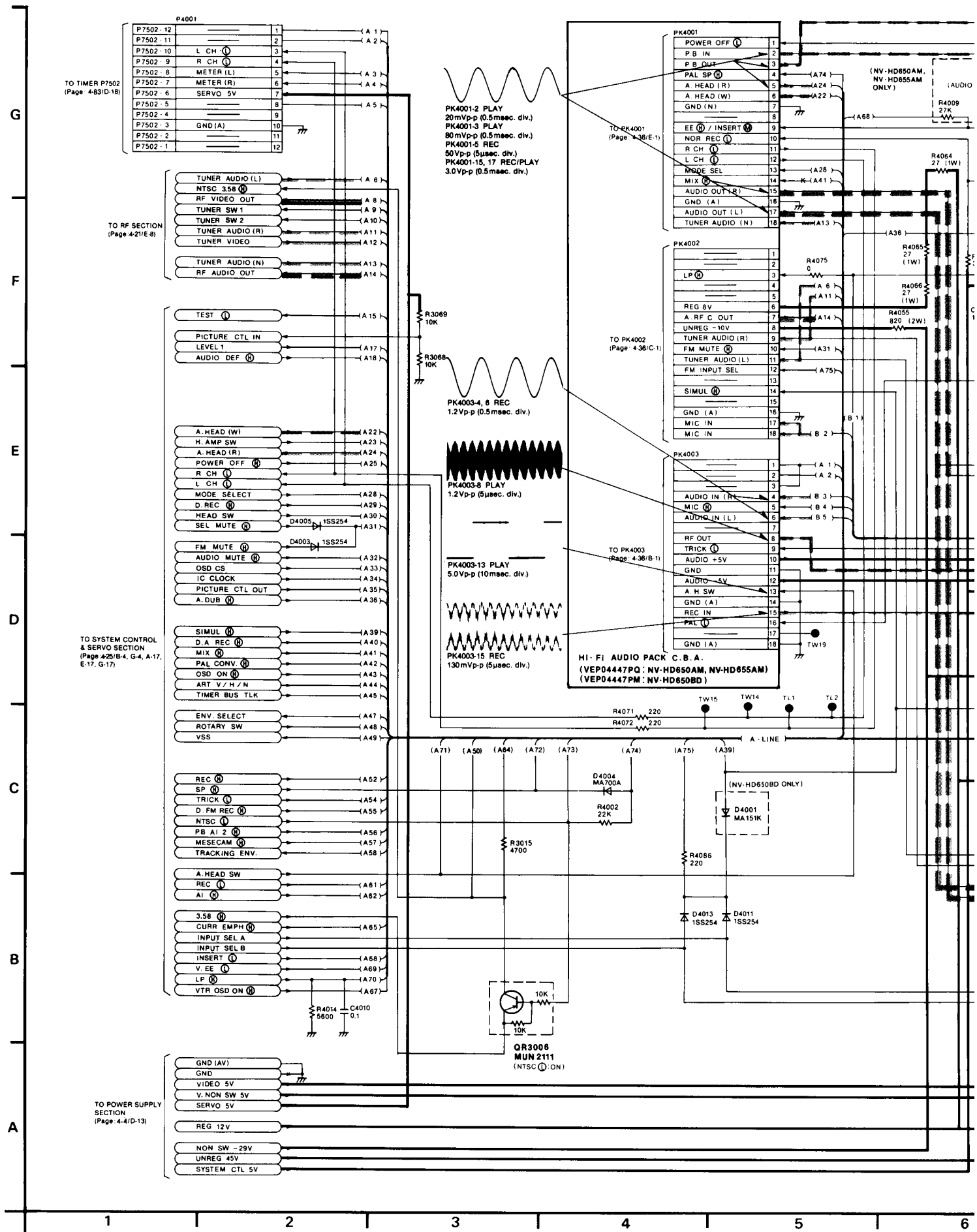



# SCHEMATIC DIAGRAM (NV-HD650AM/BD, NV-HD655AM)

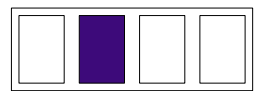
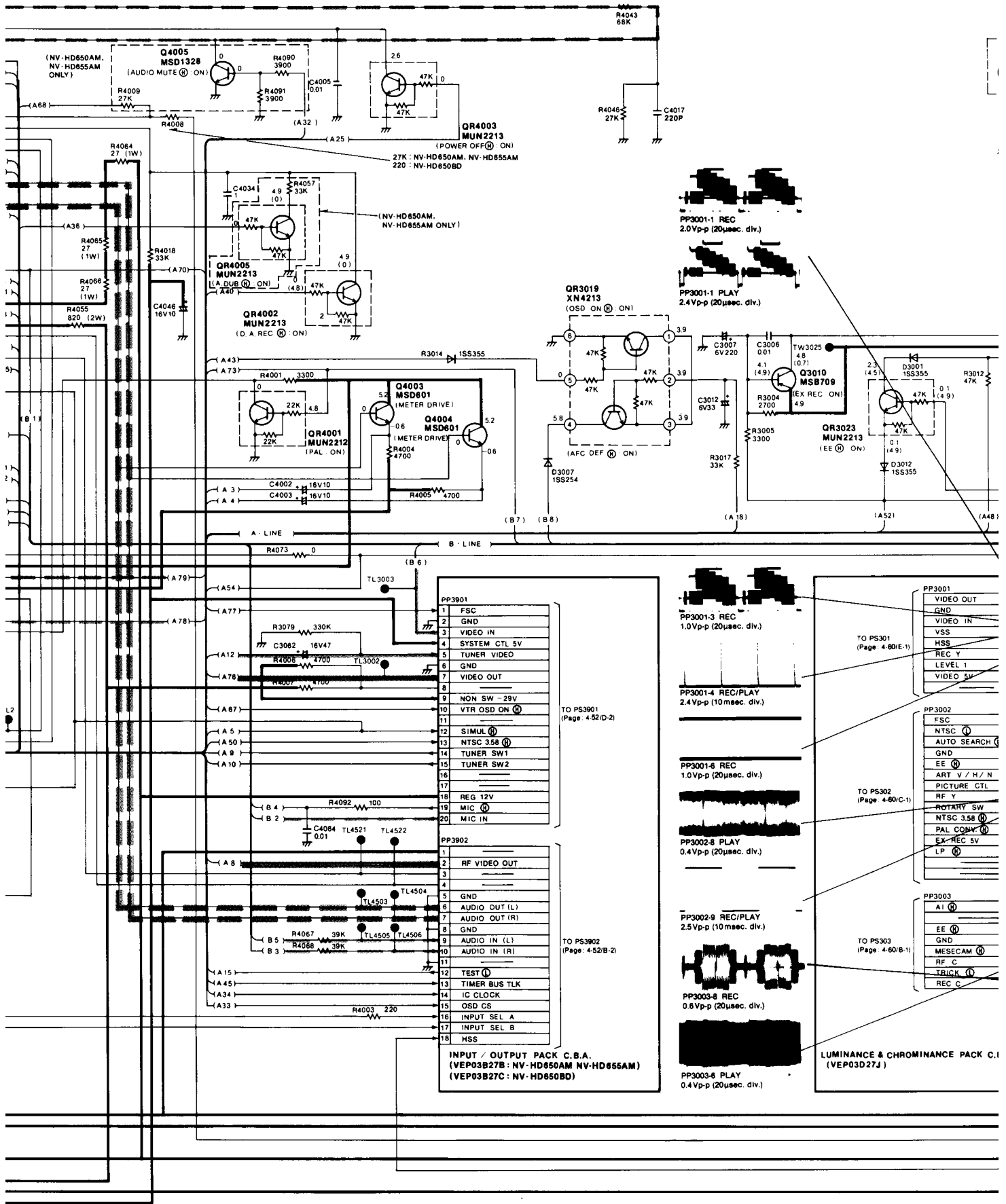

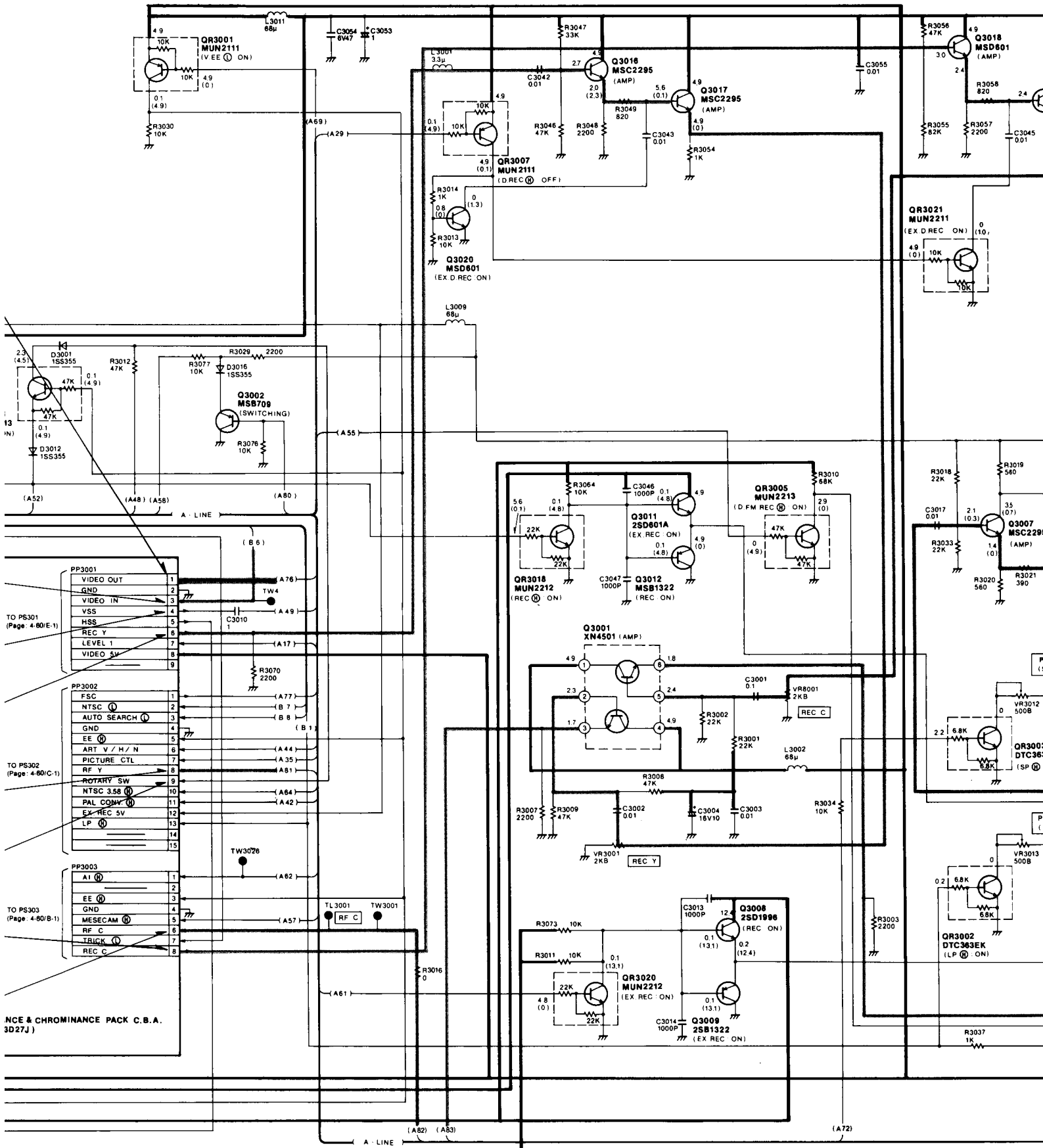

NOTE: THE MEASUREMENT MODE OF THE DC VOLTAGE IN THE BRACKETS ( ) ON THIS DIAGRAM IS WITH PAL COLOUR SIGNAL. (SP MODE)  
 THE MEASUREMENT MODE OF THE DC VOLTAGE OUT OF THE BRACKETS ON THIS DIAGRAM IS WITH PAL COLOUR SIGNAL. (SP MODE)

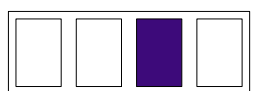

— VIDEO MAIN SIGNAL PATH IN REC MODE  
 — VIDEO MAIN SIGNAL PATH IN PLAYBACK MODE  
 - - - AUDIO MAIN SIGNAL PATH IN REC MODE  
 - - - AUDIO MAIN SIGNAL PATH IN PLAYBACK MODE

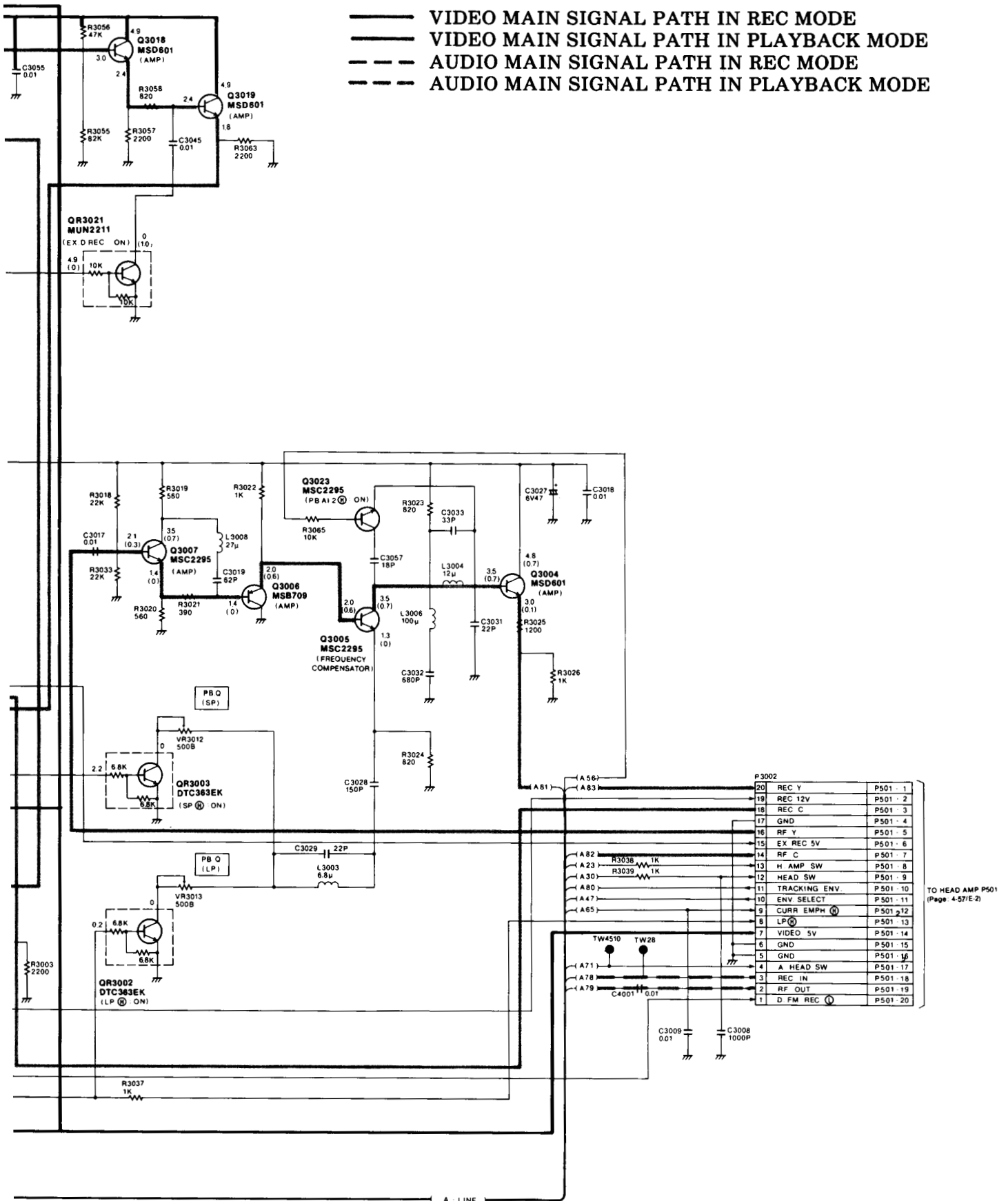

20	REC Y	P501 1
19	REC 12V	P501 2
18	REC C	P501 3
17	GND	P501 4
16	RF Y	P501 5
15	EX REC 5V	P501 6
14	RF C	P501 7
13	H AMP SW	P501 8
12	HEAD SW	P501 9
11	TRACKING ENV.	P501 10
10	ENV SELECT	P501 11
9	CURR EMPH	P501 12
8	LP	P501 13
7	VIDEO 5V	P501 14
6	GND	P501 15
5	GND	P501 16
4	A HEAD SW	P501 17
3	REC IN	P501 18
2	RF OUT	P501 19
1	D FM REC	P501 20

TO HEAD AMP P501 (Page 4-57/E-2)

IN THE BRACKETS ( ) ON THIS DIAGRAM IS RECORD MODE  
 OUT OF THE BRACKETS ON THIS DIAGRAM IS PLAYBACK MODE

NOTE: DO NOT USE ANY PART NUMBER SHOWN ON THIS SCHEMATIC DIAGRAM FOR ORDERING. WHEN YOU ORDER A PART, PLEASE REFER TO PARTS LIST.

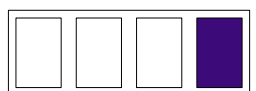

# 4-7. RF SECTION IN MAIN SCHEMATIC DIAGRAM

—— VIDEO MAIN SIGNAL PAT  
 - - - - VIDEO MAIN SIGNAL PAT

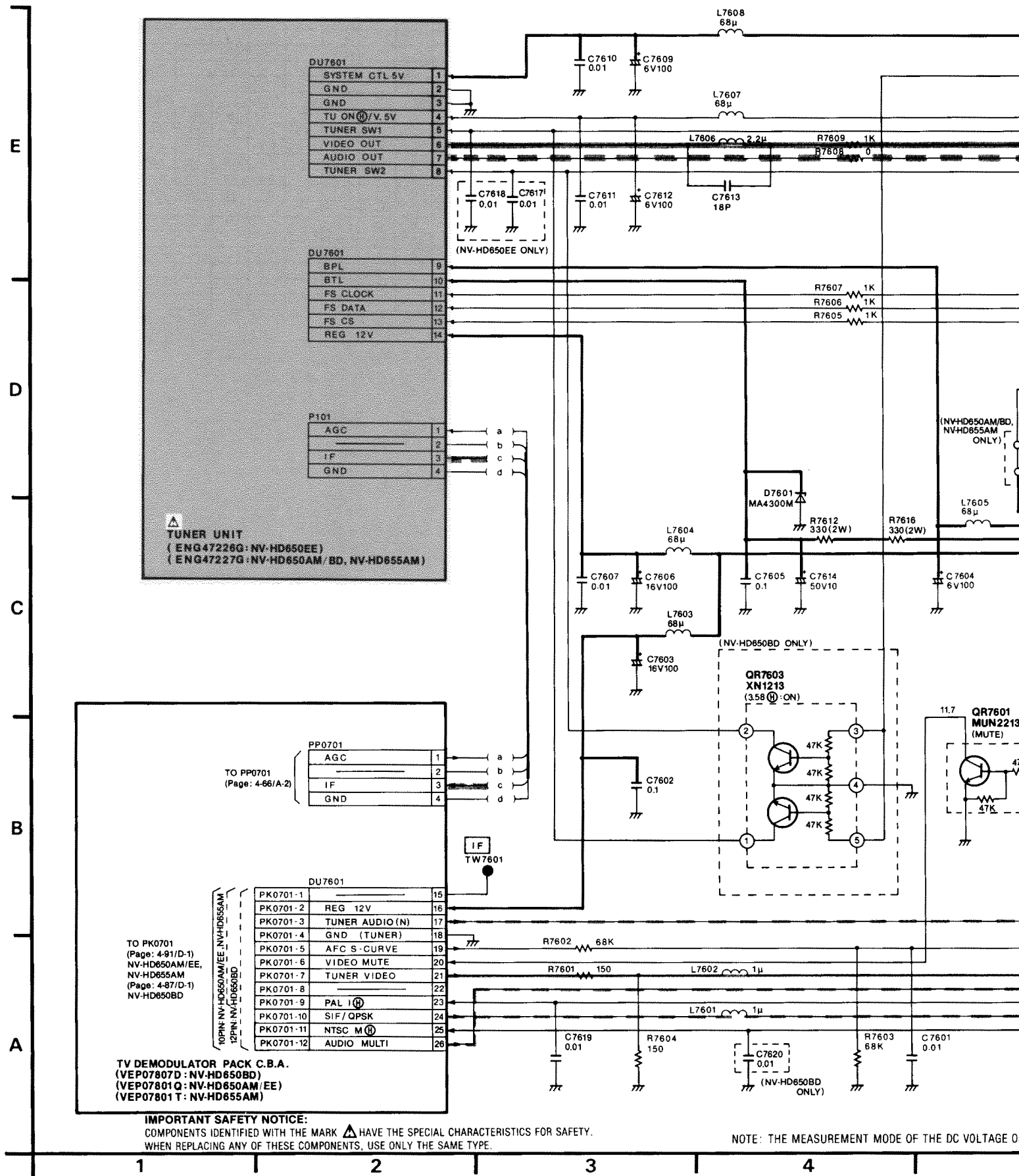

**IMPORTANT SAFETY NOTICE:**  
 COMPONENTS IDENTIFIED WITH THE MARK HAVE THE SPECIAL CHARACTERISTICS FOR SAFETY.  
 WHEN REPLACING ANY OF THESE COMPONENTS, USE ONLY THE SAME TYPE.

NOTE: THE MEASUREMENT MODE OF THE DC VOLTAGE OF

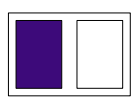



IN SIGNAL PATH IN REC MODE  
IN SIGNAL PATH IN PLAYBACK MODE

AUDIO MAIN SIGNAL PATH IN REC MODE  
AUDIO MAIN SIGNAL PATH IN PLAYBACK MODE

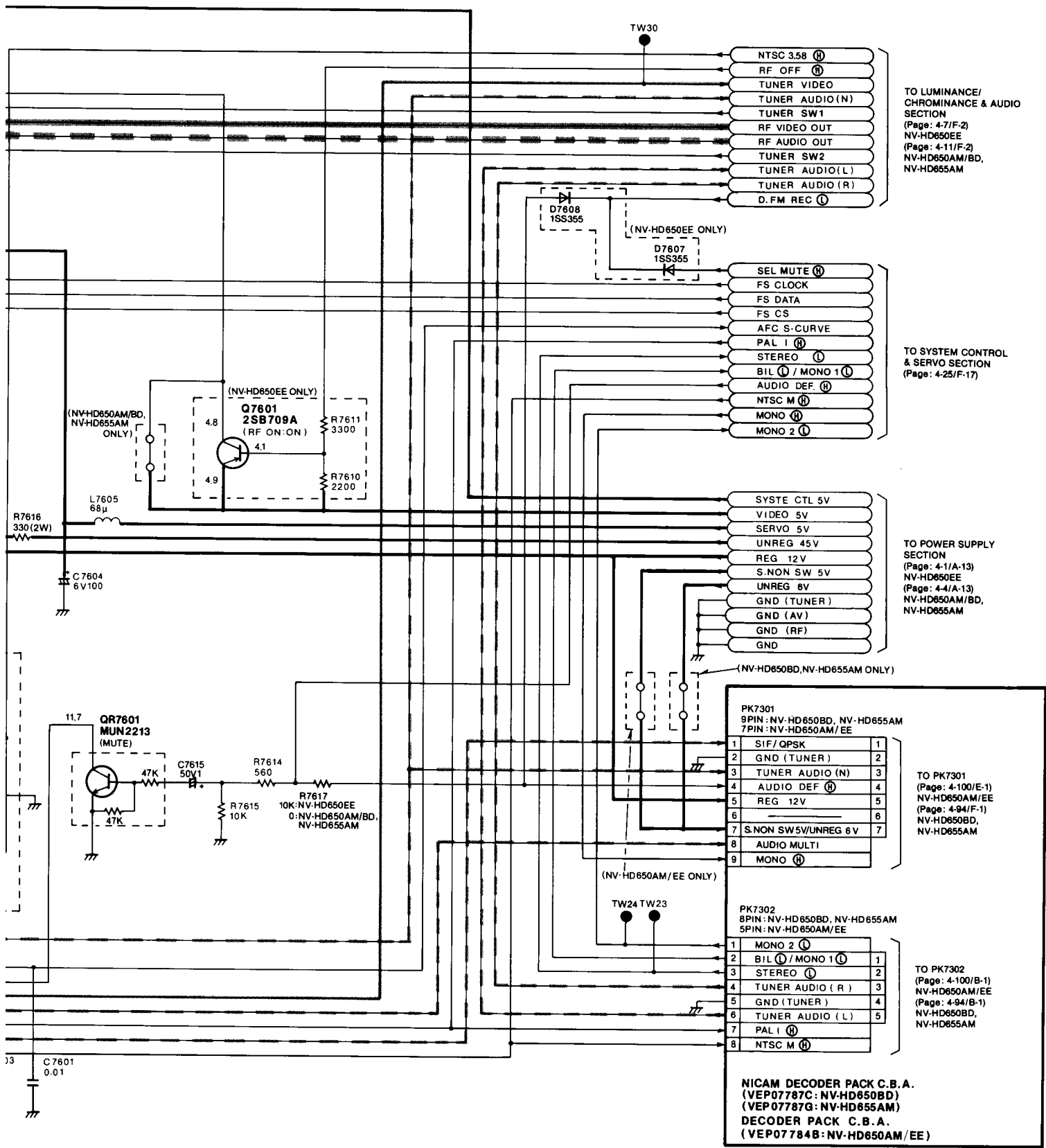

DE OF THE DC VOLTAGE ON THIS DIAGRAM IS STOP MODE.

NOTE: DO NOT USE ANY PART NUMBER SHOWN ON THIS SCHEMATIC DIAGRAM FOR ORDERING. WHEN YOU ORDER A PART, PLEASE REFER TO PARTS LIST.

5

6

7

8



# 4-8. SYSTEM CONTROL & SERVO SECTION IN MAIN SCHEMATIC DIAGRAM

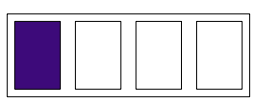
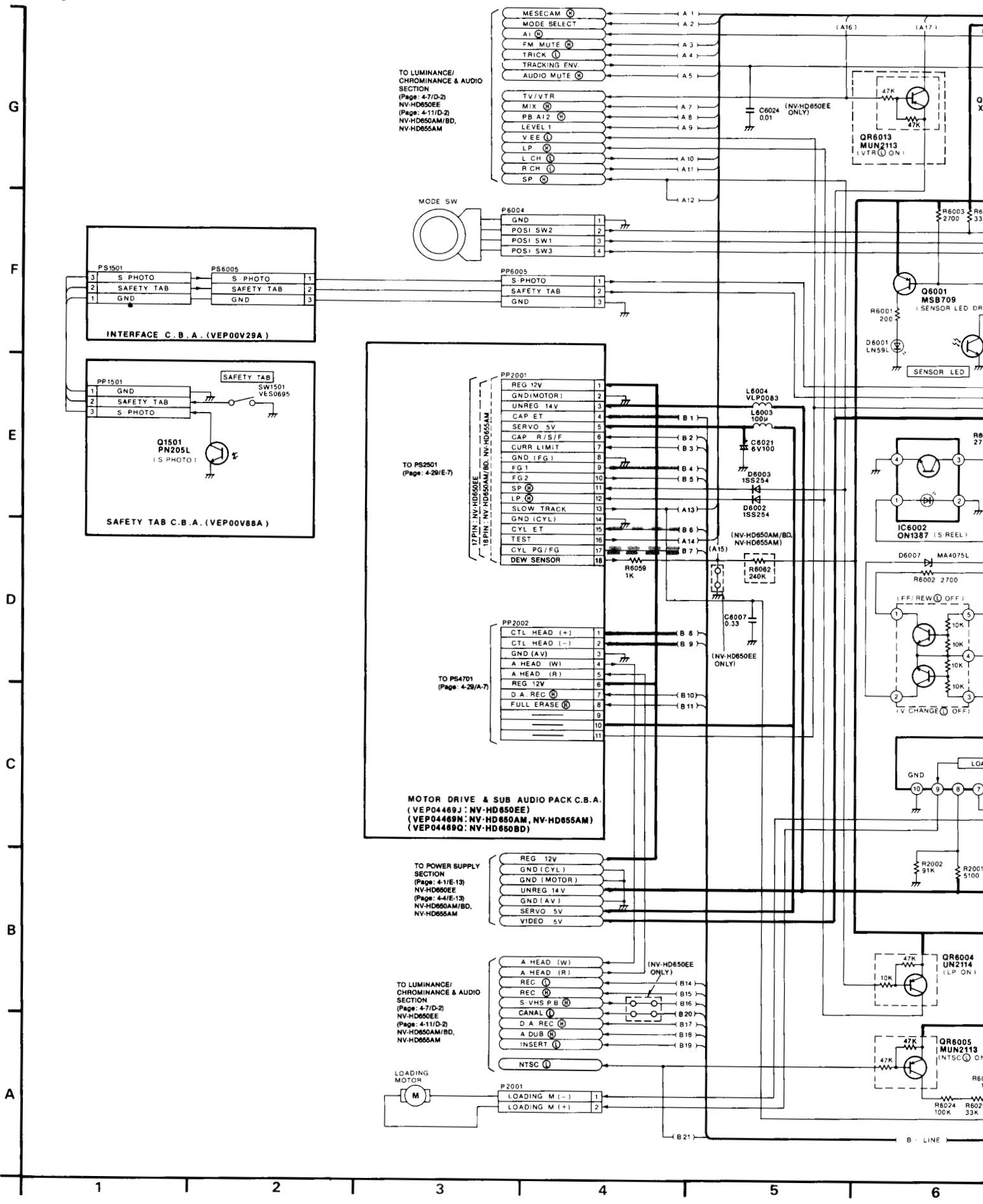

# SCHEMATIC DIAGRAM

# CAPSTAN SERVO SPEAKER

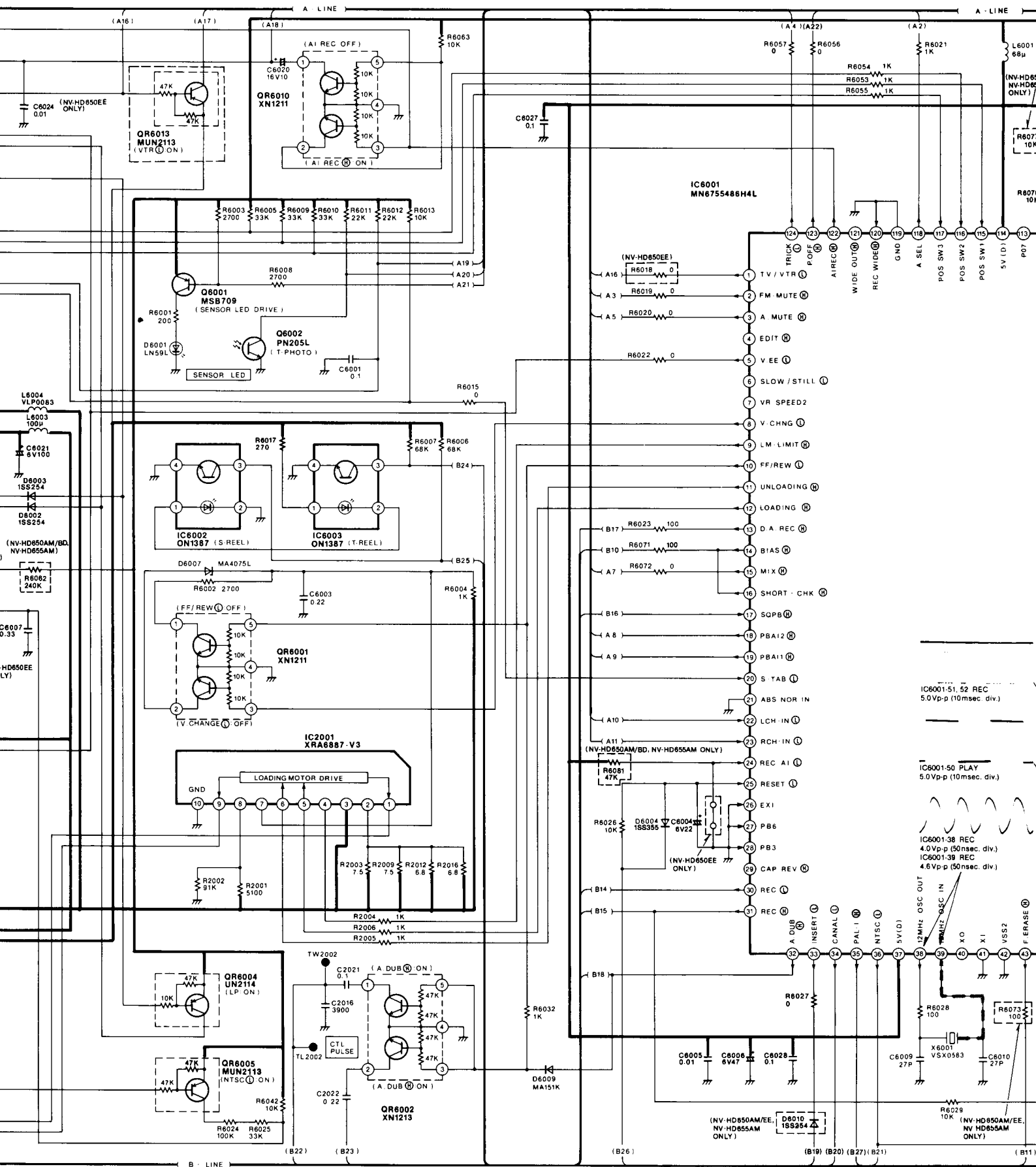

IC6001-51, 52 REC  
5.0Vp-p (10msec. div.)

IC6001-50 PLAY  
5.0Vp-p (10msec. div.)

IC6001-38 REC  
4.0Vp-p (50nsec. div.)  
IC6001-39 REC  
4.6Vp-p (50nsec. div.)

12MHz OSC OUT  
12MHz OSC IN

5 6 7 8 9 10

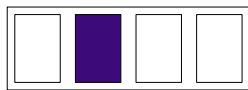

N SERVO SPEED LOOP — CAPSTAN SERVO PHASE LOOP — CYLINDER SERVO SPEED LOOP

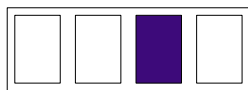
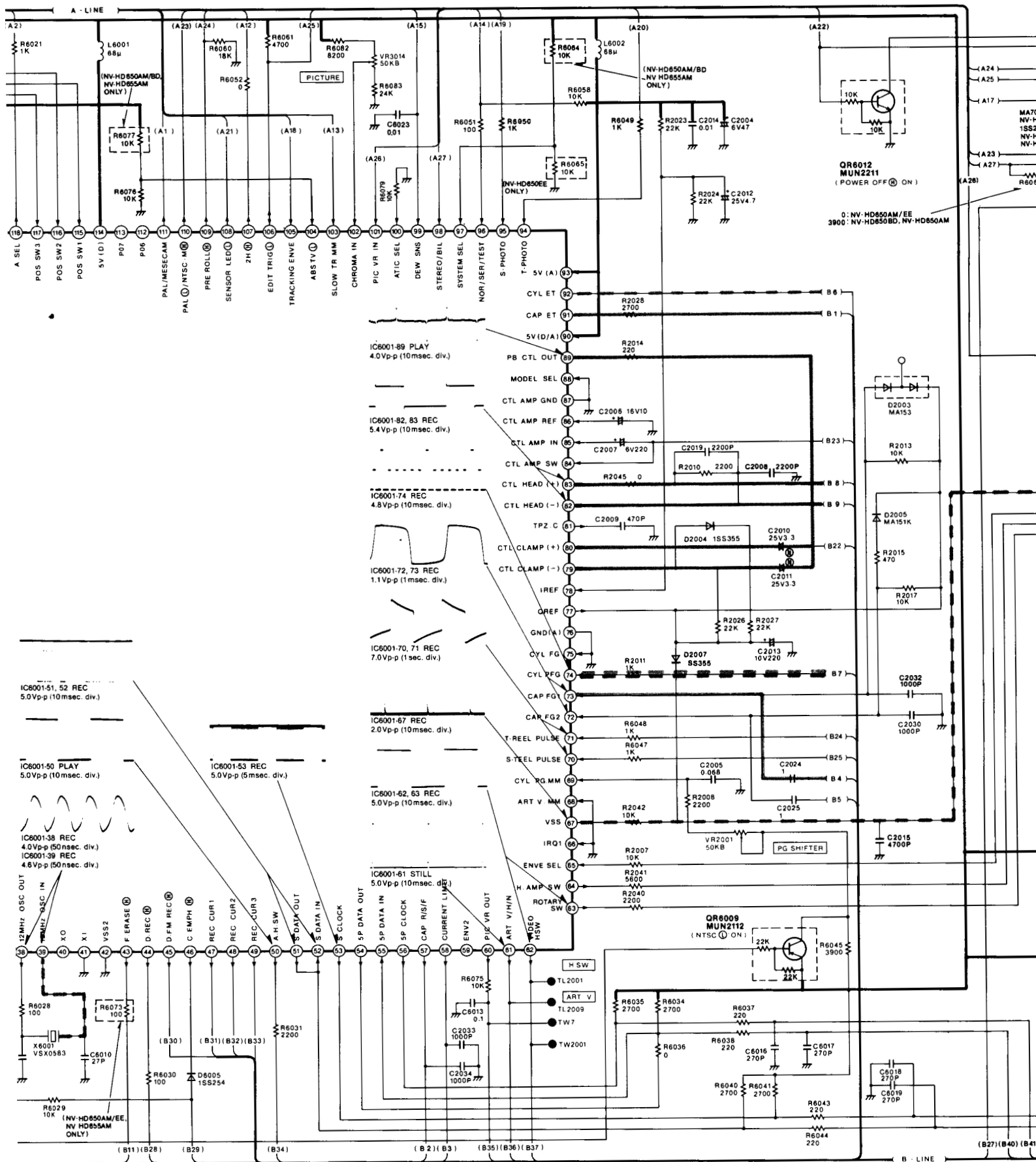



R SERVO SPEED LOOP --- CYLINDER SERVO PHASE LOOP

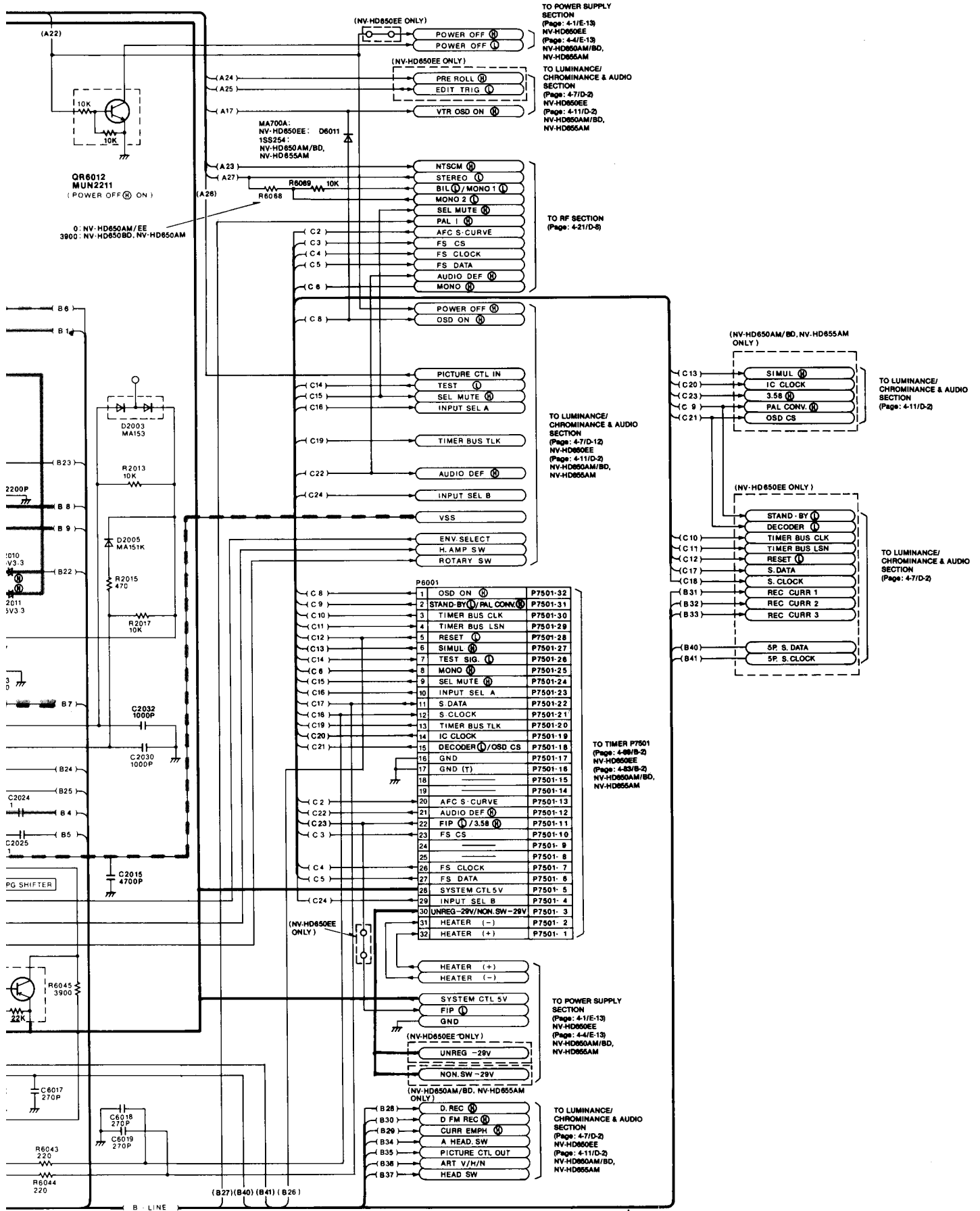

NOTE: DO NOT USE ANY PART NUMBER SHOWN ON THIS SCHEMATIC DIAGRAM FOR ORDERING. WHEN YOU ORDER A PART, PLEASE REFER TO PARTS LIST.

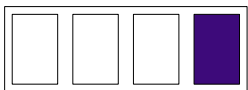

### 4-9. MOTOR DRIVE & SUB AUDIO PACK SCHEMATIC DIAGRAM

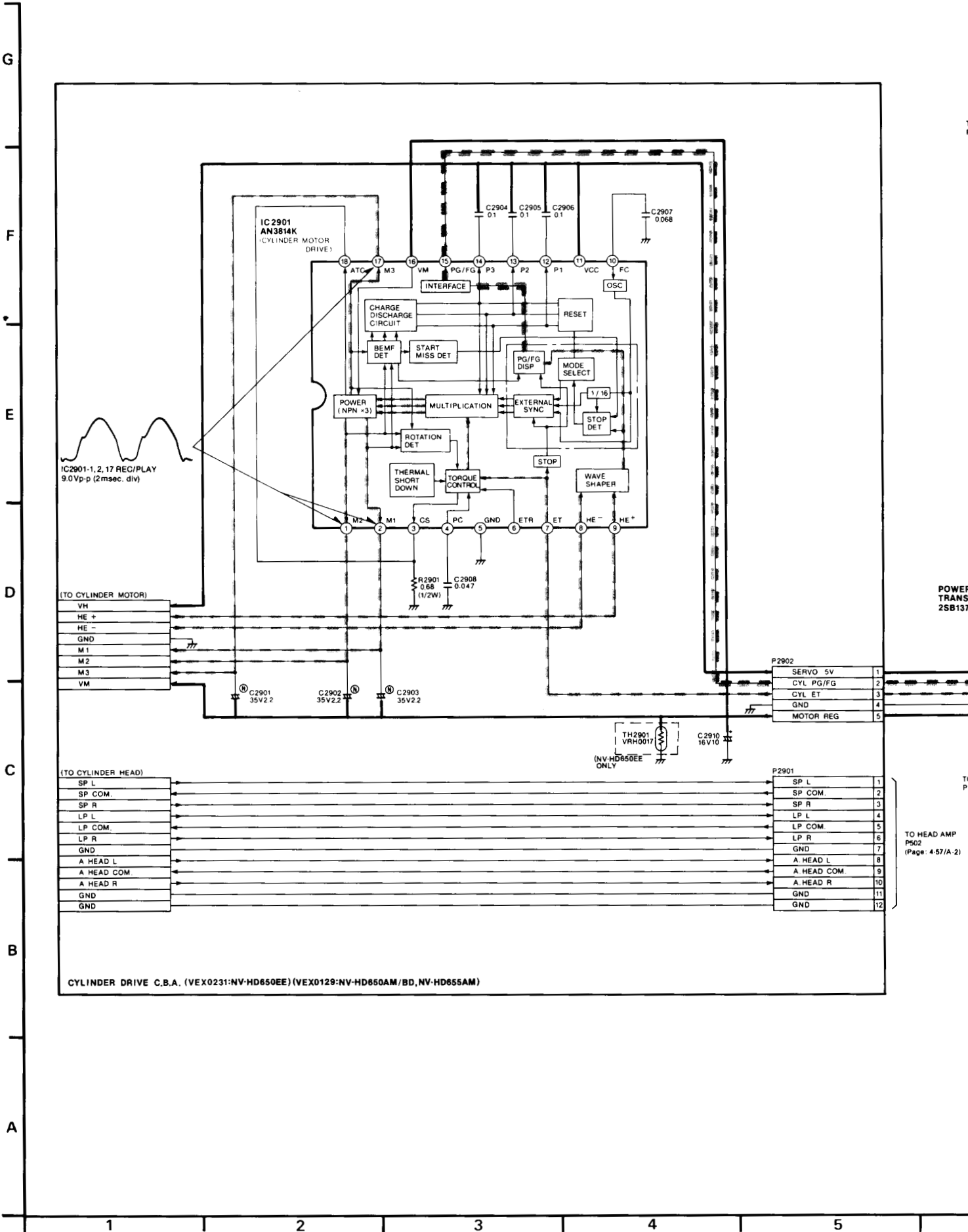

POWER TRANS 2SB137

TO HEAD AMP P502 (Page: 4-57/A-2)

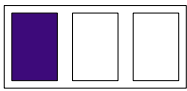

**WIRING DIAGRAM**

CAPSTAN SERVO  
CYLINDER SERVO

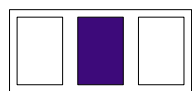
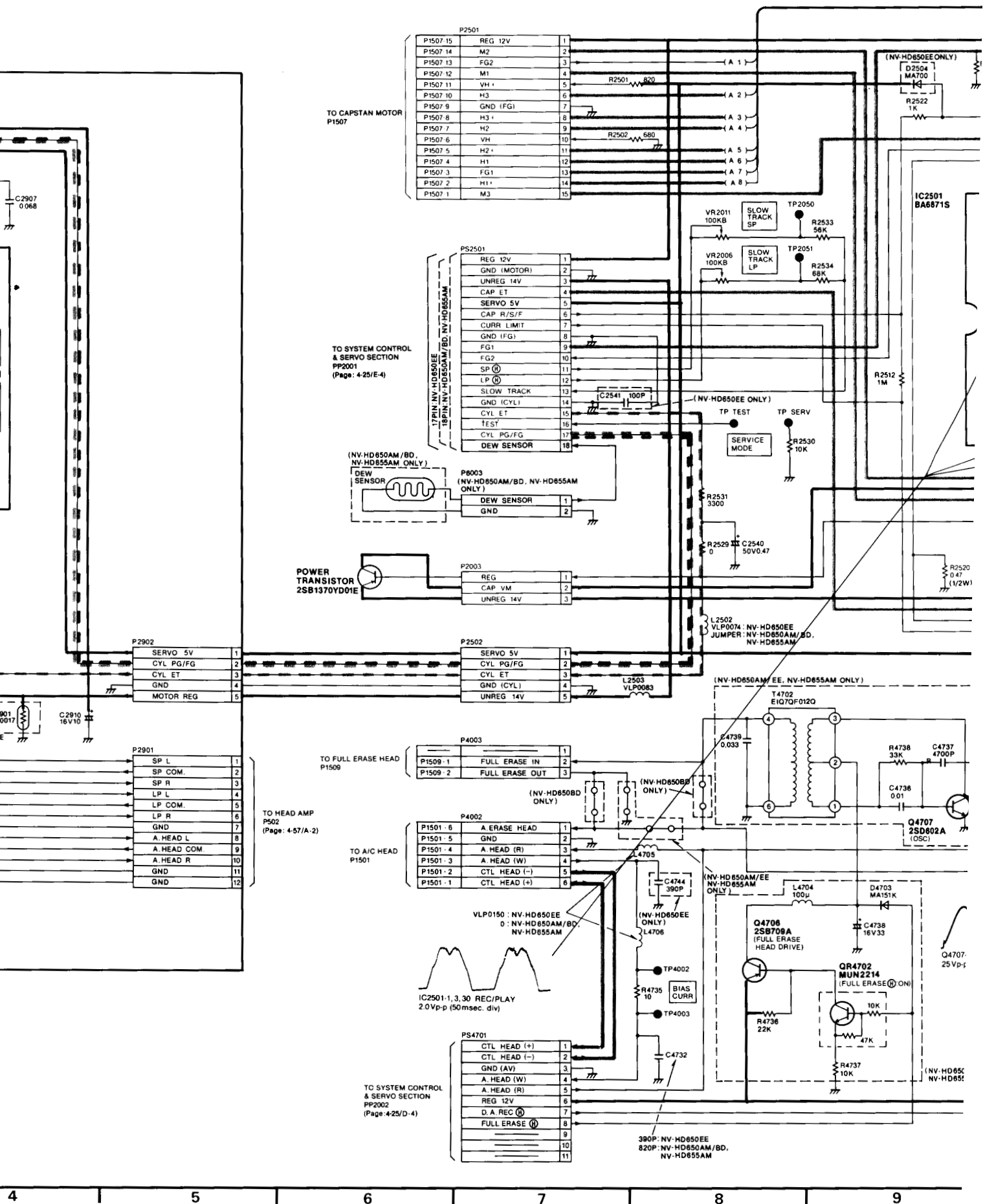

——— CAPSTAN SERVO SPEED LOOP      ——— CAPSTAN SERVO PHASE LOOP  
 - - - CYLINDER SERVO SPEED LOOP      - - - CYLINDER SERVO PHASE LOOP

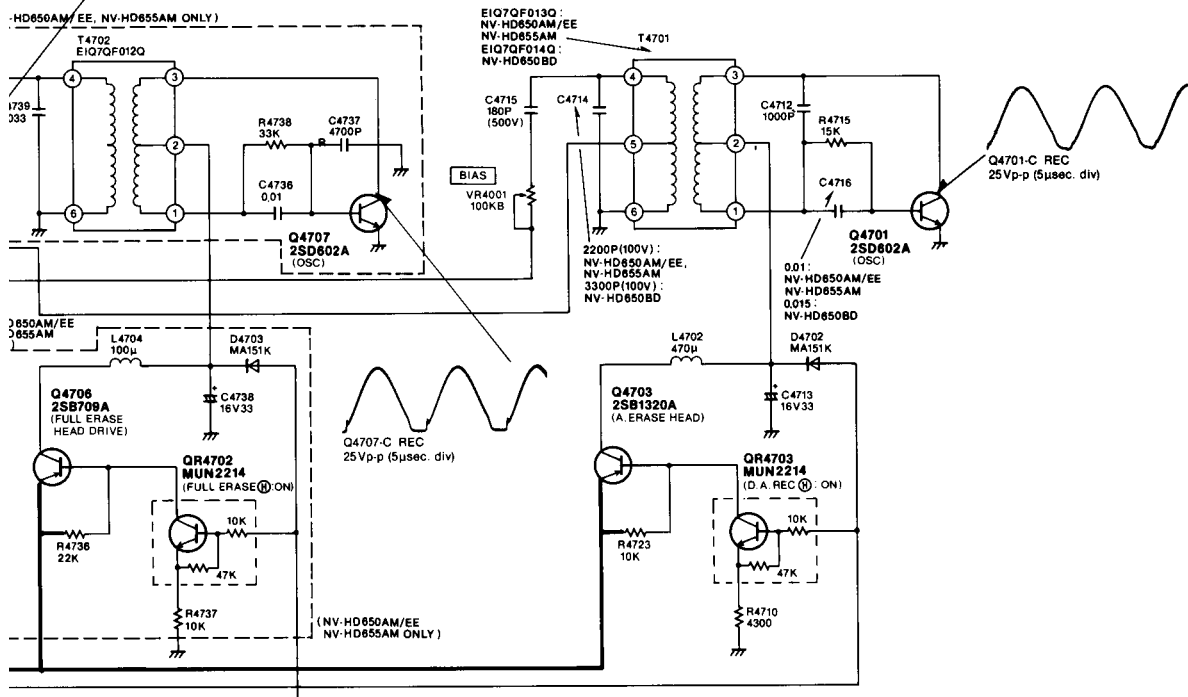
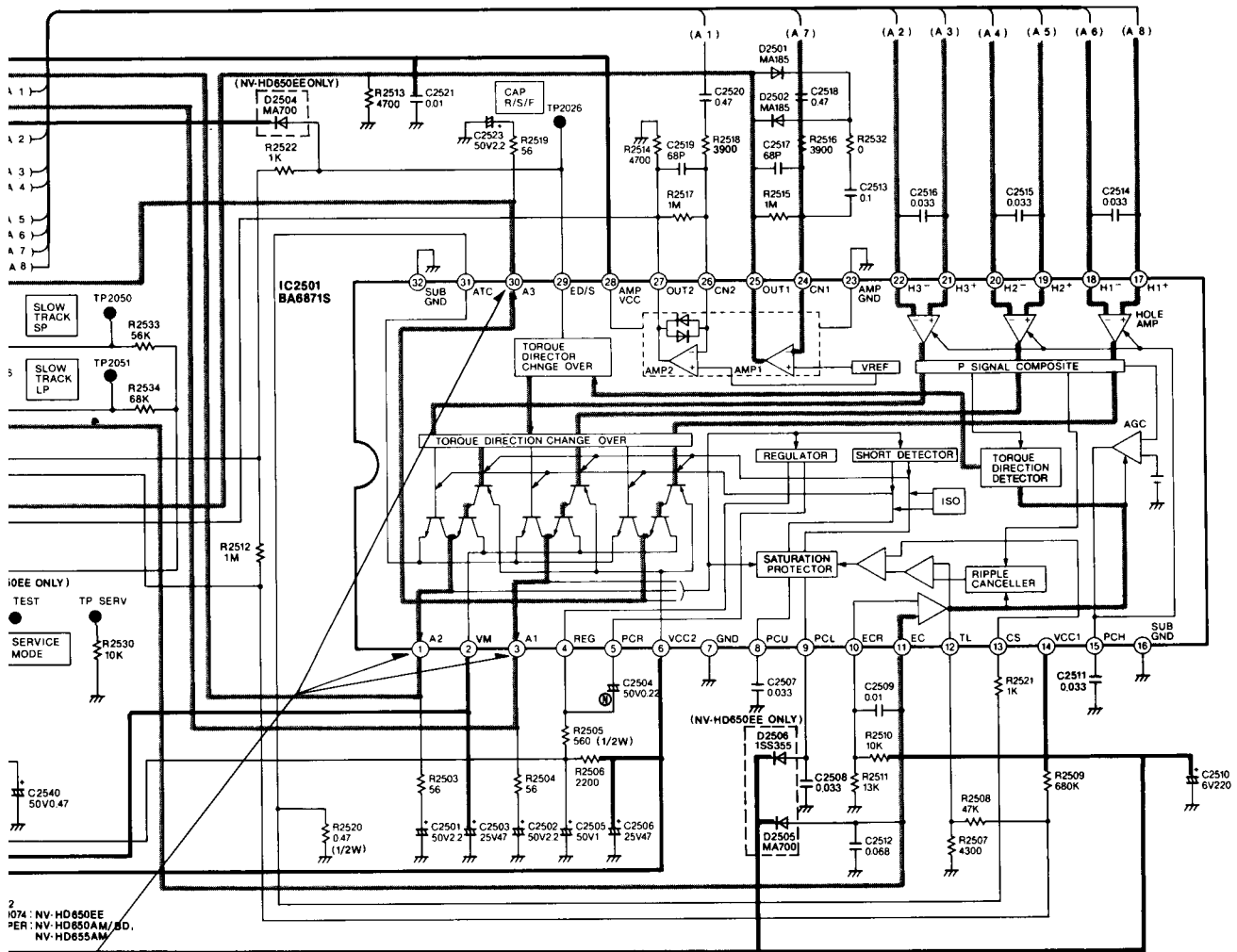

NOTE: DO NOT USE ANY PART NUMBER SHOWN ON THIS SCHEMATIC DIAGRAM FOR ORDERING. WHEN YOU ORDER A PART, PLEASE REFER TO PARTS LIST.

9

10

11

12

13

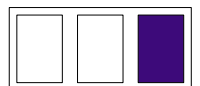



### MOTOR DRIVE & SUB AUDIO PACK ICs DC VOLTAGE CHART (SP MODE)

REF. NO.	IC2501																			
MODE	1	2	3	4	5	6	7	8	9	10	11	12	13	14	15	16	17	18	19	20
STOP	0.6	4.4	0.6	13.2	0.1	13.9	0	4.5	0.7	2.8	0.2	0.4	0	4.9	1.5	0	2.3	2.3	2.3	2.2
PLAY	2.6	4.3	2.6	12.4	1.9	13.6	0	0.7	0.7	2.8	2.5	0.4	0.1	4.9	1.5	0	2.3	2.3	2.3	2.3
REC	2.7	4.3	2.7	12.4	2.0	13.6	0	0.7	0.7	2.8	2.5	0.4	0.1	5.0	1.5	0	2.3	2.3	2.3	2.3
F.F	7.5	13.4	7.5	4.3	11.6	13.5	0.1	0.8	0.8	2.8	2.0	0.5	0.2	4.9	1.5	0	2.3	2.3	2.3	2.3
REW	7.0	13.5	7.0	6.9	11.7	13.6	0	0.7	0.8	2.8	2.3	0.5	0.1	4.9	1.5	0	2.3	2.3	2.3	2.3

REF. NO.	IC2501											
MODE	21	22	23	24	25	26	27	28	29	30	31	32
STOP	2.2	2.3	0	6.3	6.3	6.3	6.3	12.3	2.0	0.6	0	0
PLAY	2.3	2.3	0	6.3	6.3	6.3	6.3	12.3	0	2.6	0	0
REC	2.3	2.3	0	6.3	6.3	6.3	6.3	12.3	0	2.6	0.1	0
F.F	2.3	2.3	0	6.3	6.3	6.3	6.3	12.3	0	7.5	0.2	0
REW	2.3	2.3	0	6.3	6.3	6.3	6.3	12.3	4.9	7.4	0.2	0

REF. NO.	IC2901																	
MODE	1	2	3	4	5	6	7	8	9	10	11	12	13	14	15	16	17	18
STOP	13.1	13.1	0.1	0.6	0	2.5	2.4	2.6	2.5	2.6	4.9	3.7	3.6	3.7	1.3	13.8	13.3	0.1
PLAY	13.8	12.8	0.2	0.6	0	2.5	2.4	2.6	2.5	2.7	4.9	3.7	3.7	3.7	1.4	13.6	13.7	0.2
REC	13.7	13.7	0.2	0.6	0	2.5	2.4	2.6	2.5	2.7	4.9	3.8	3.7	3.7	1.5	13.6	13.7	0.2
F.F	13.8	13.8	0.1	0.6	0	2.5	2.4	2.6	2.5	2.7	4.9	3.8	3.7	3.7	1.5	13.5	13.7	0.1
REW	13.8	13.8	0.2	0.6	0	2.5	2.4	2.6	2.5	2.7	4.9	3.7	3.7	3.7	1.5	13.5	13.7	0.2

### MOTOR DRIVE & SUB AUDIO PACK PINs DC VOLTAGE CHART (SP MODE)

REF. NO.	PS2501																
MODE	1	2	3	4	5	6	7	8	9	10	11	12	13	14	15	16	17
STOP	12.3	0	13.8	0.2	4.9	2.0	4.9	0	6.3	6.3	4.4	0	0	0	2.4	5.0	1.4
PLAY	12.3	0	13.6	2.5	4.9	0	4.9	0	6.3	6.3	4.4	0	0	0	2.4	4.9	1.4
REC	12.3	0	13.6	2.5	4.9	0	4.9	0	6.3	6.3	4.4	0	0	0	2.4	4.9	1.4
F.F	12.3	0	13.5	2.1	4.9	0	4.9	0	6.3	6.3	4.4	0	0	0	2.4	4.9	1.4
REW	12.3	0	13.5	2.1	4.9	4.9	4.9	0	6.3	6.3	4.4	0	0	0	2.4	4.9	1.4

REF. NO.	PS4701										
MODE	1	2	3	4	5	6	7	8	9	10	11
STOP	0	0	0	0	0	12.3	0	0	0	4.9	0
PLAY	0	0	0	0	0	12.3	0	0	0	4.9	0
REC	3.5	3.5	0	0	0	12.3	4.9	4.7	0	4.9	0
F.F	0	0	0	0	0	12.3	0	0	0	4.9	0
REW	0	0	0	0	0	12.3	0	0	0	4.9	0

### MOTOR DRIVE & SUB AUDIO PACK TR.s DC VOLTAGE CHART (SP MODE)

REF. NO.	Q4701			Q4703			Q4706			Q4707		
MODE	E	C	B	E	C	B	E	C	B	E	C	B
STOP	0	0.2	0.2	12.3	0.3	12.3	12.5	0.4	12.5	0	0.4	0.3
PLAY	0	0.3	0.3	12.3	0.3	12.3	12.5	0.4	12.5	0	0.4	0.3
REC	0	11.3	-1.4	12.3	11.9	11.9	12.5	12.5	11.7	0	12.2	0
F.F	0	0.3	0.3	12.3	0.3	12.3	12.5	0.4	12.5	0	0.4	0.3
REW	0	0.3	0.3	12.3	0.3	12.3	12.5	0.4	12.5	0	0.4	0.3

  

REF. NO.	QR4702			QR4703		
MODE	E	C	B	E	C	B
STOP	0	12.5	0	0	12.3	0
PLAY	0	12.5	0	0	12.3	0
REC	3.6	11.7	4.7	4.1	11.5	4.9
F.F	0	12.5	0	0	12.3	0
REW	0	12.5	0	0	12.3	0

# 4-11. Hi-Fi AUDIO PACK SCHEMATIC DIAGRAM

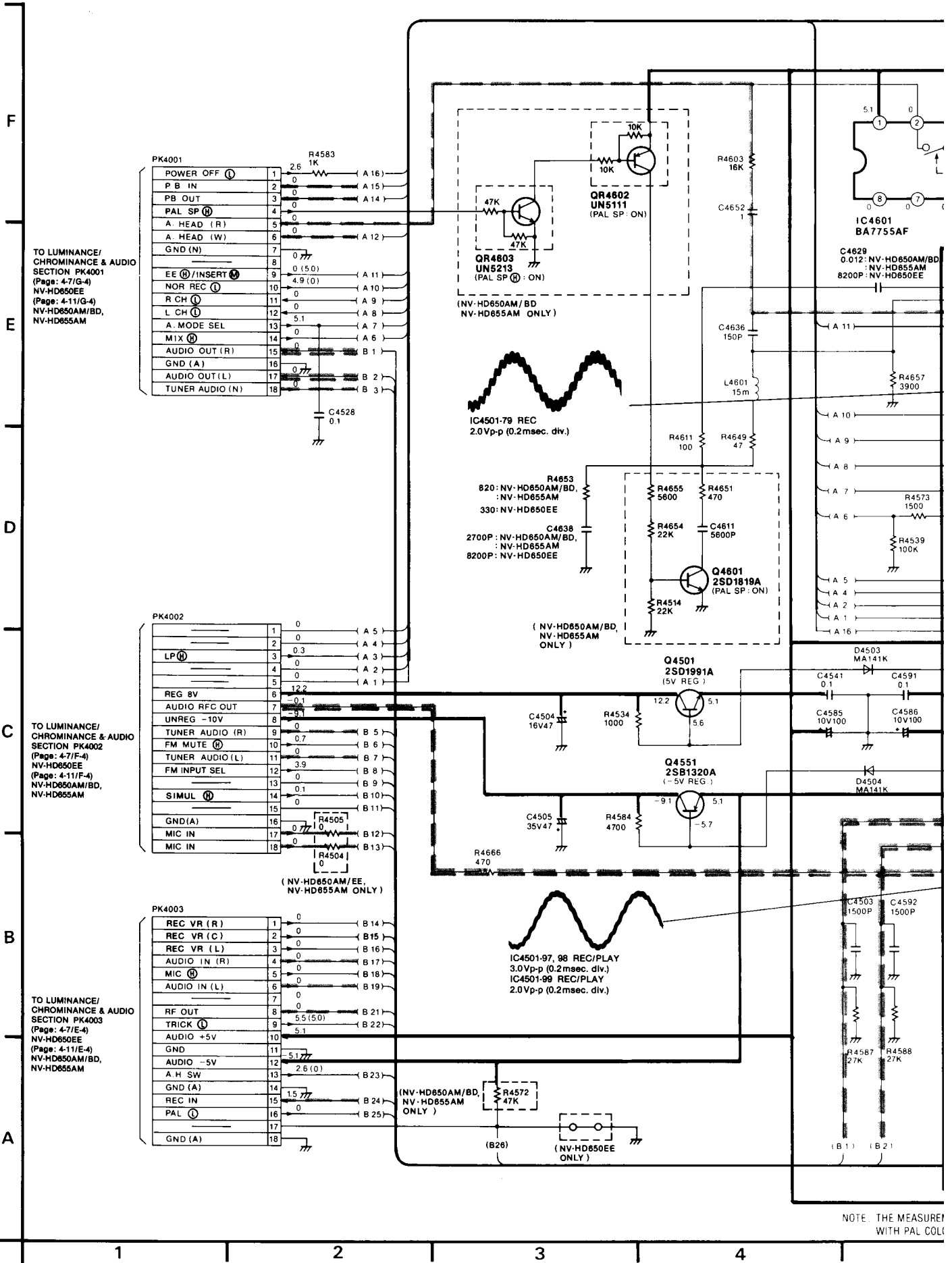

NOTE: THE MEASUREMENTS WERE MADE WITH PAL COLOR

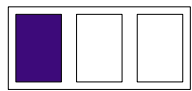

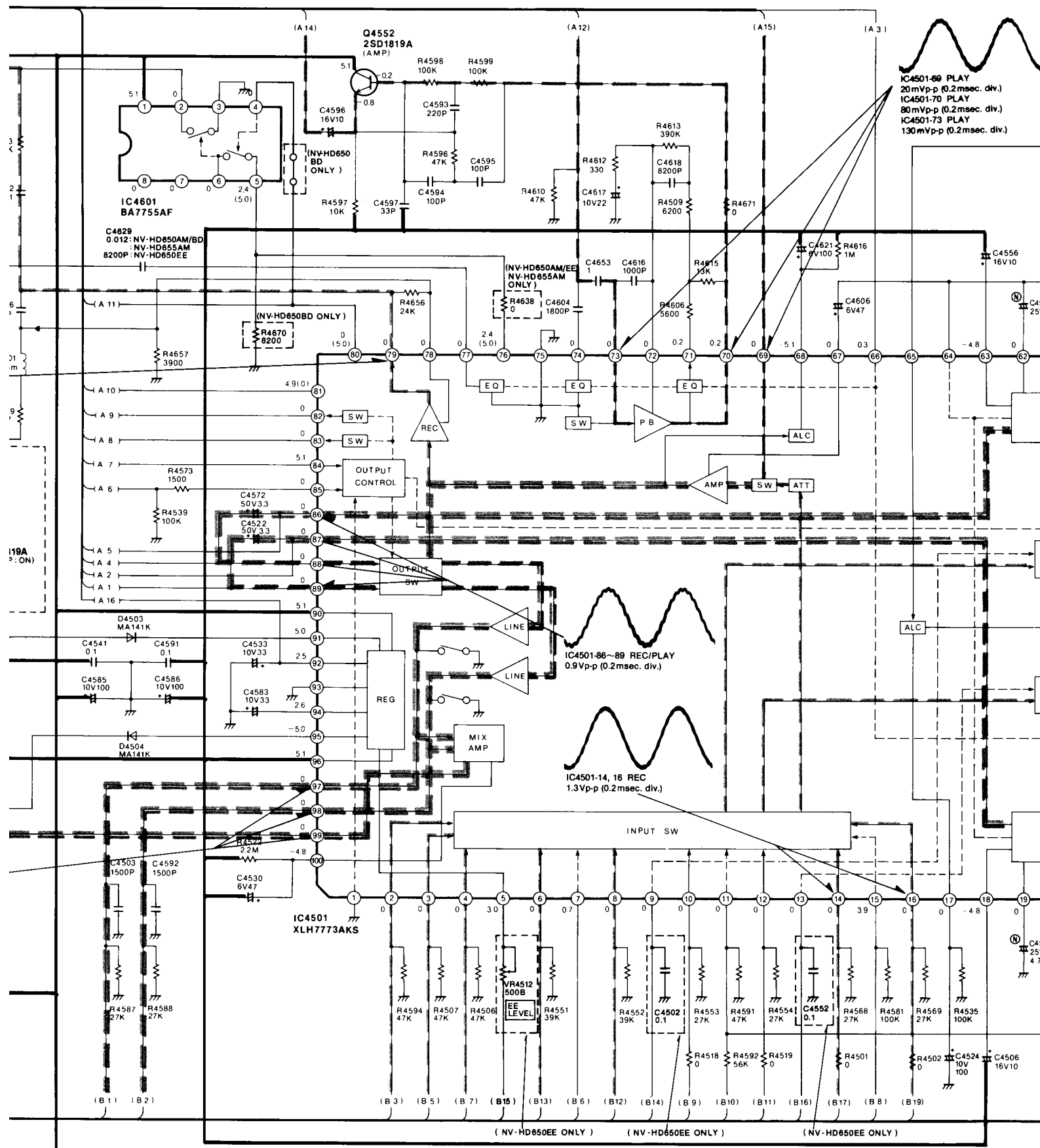

NOTE: THE MEASUREMENT MODE OF THE DC VOLTAGE IN THE BRACKETS ( ) ON THIS DIAGRAM IS RECORD MODE WITH PAL COLOUR SIGNAL. (SP MODE)

THE MEASUREMENT MODE OF THE DC VOLTAGE OUT OF THE BRACKETS ON THIS D WITH PAL COLOUR SIGNAL. (SP MODE)

5 6 7 8 9

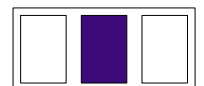

SIGNAL PATH IN REC MODE

MAIN SIGNAL PATH IN PLAYBACK MODE



IC4501-69 PLAY  
p-p (0.2msec. div.)  
IC4501-70 PLAY  
p-p (0.2msec. div.)  
IC4501-73 PLAY  
Vp-p (0.2msec. div.)



IC4501-53, 54 REC/PLAY  
0.9Vp-p (0.2msec. div.)

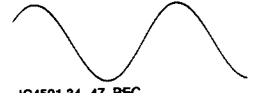

IC4501-34, 47 REC  
0.3Vp-p (0.2msec. div.)

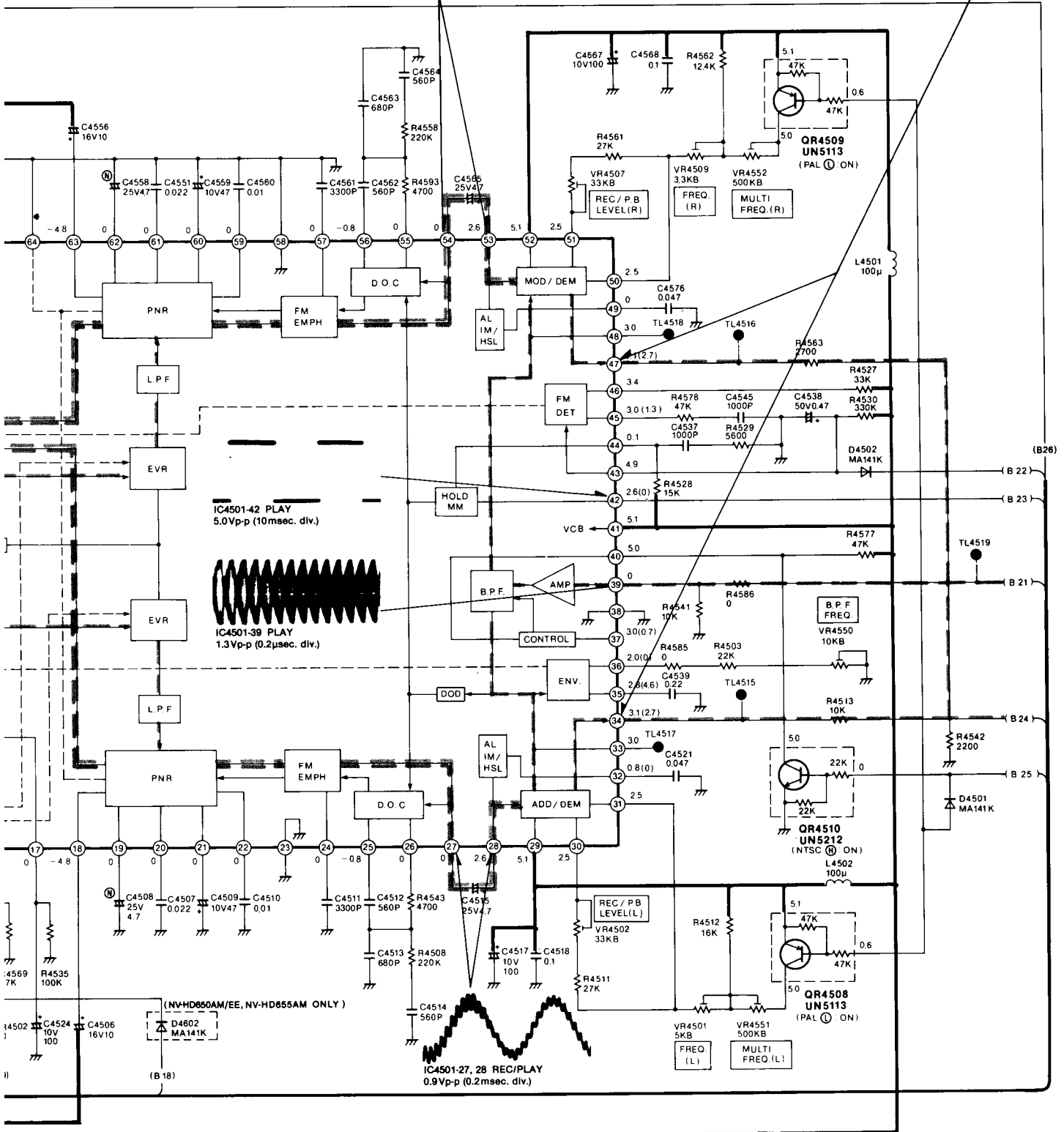

IF THE BRACKETS ON THIS DIAGRAM IS PLAYBACK MODE

• LINE IN SIGNAL LEVEL... 10dB 1kHz

NOTE: DO NOT USE ANY PART NUMBER SHOWN ON THIS SCHEMATIC DIAGRAM FOR ORDERING. WHEN YOU ORDER A PART, PLEASE REFER TO PARTS LIST.

9

10

11

12

13

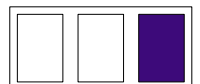



### 4-13. OSD PACK SCHEMATIC DIAGRAM (NV-HD650EE)

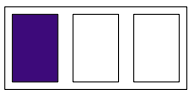
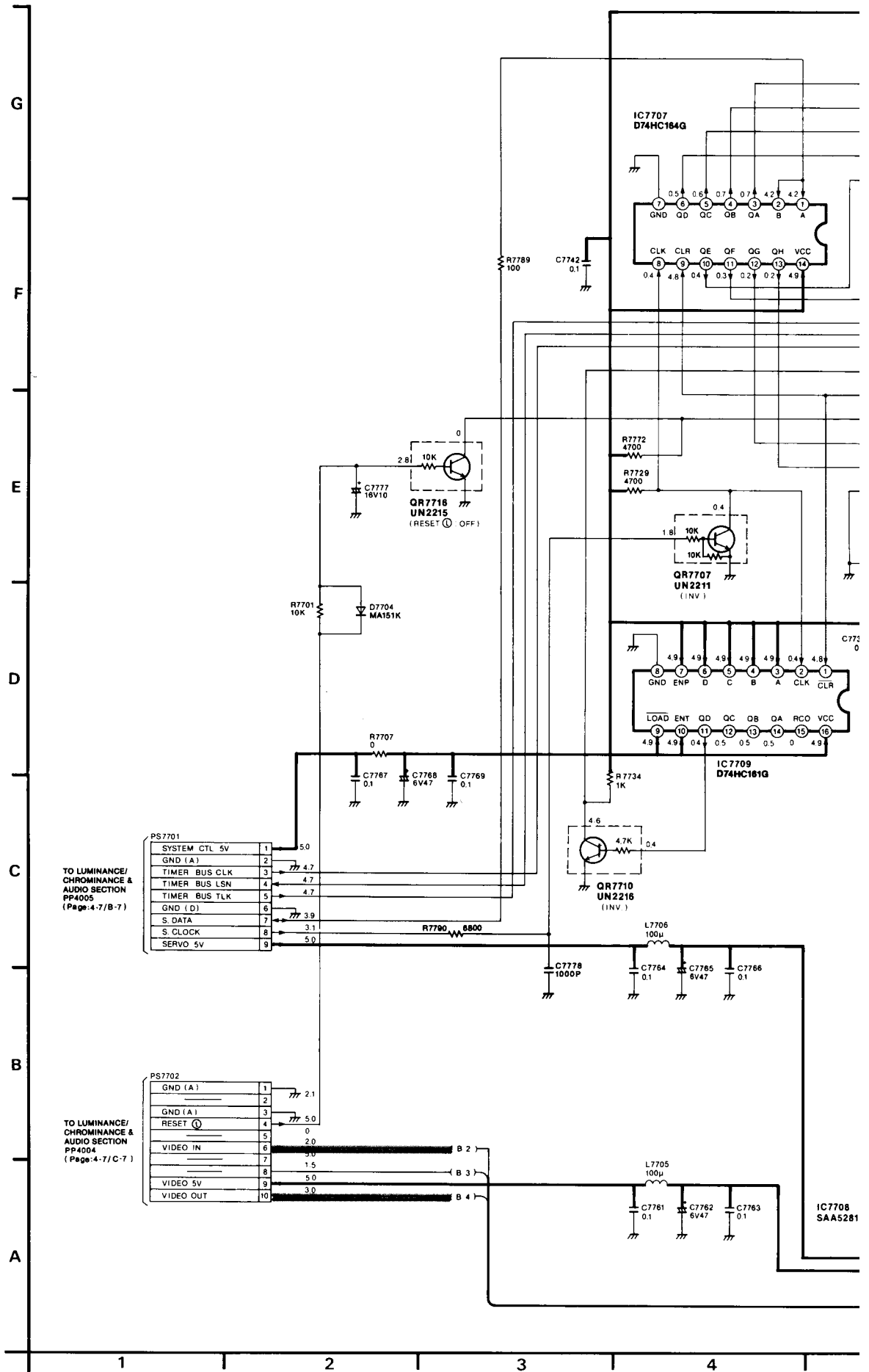

**ID650EE)**

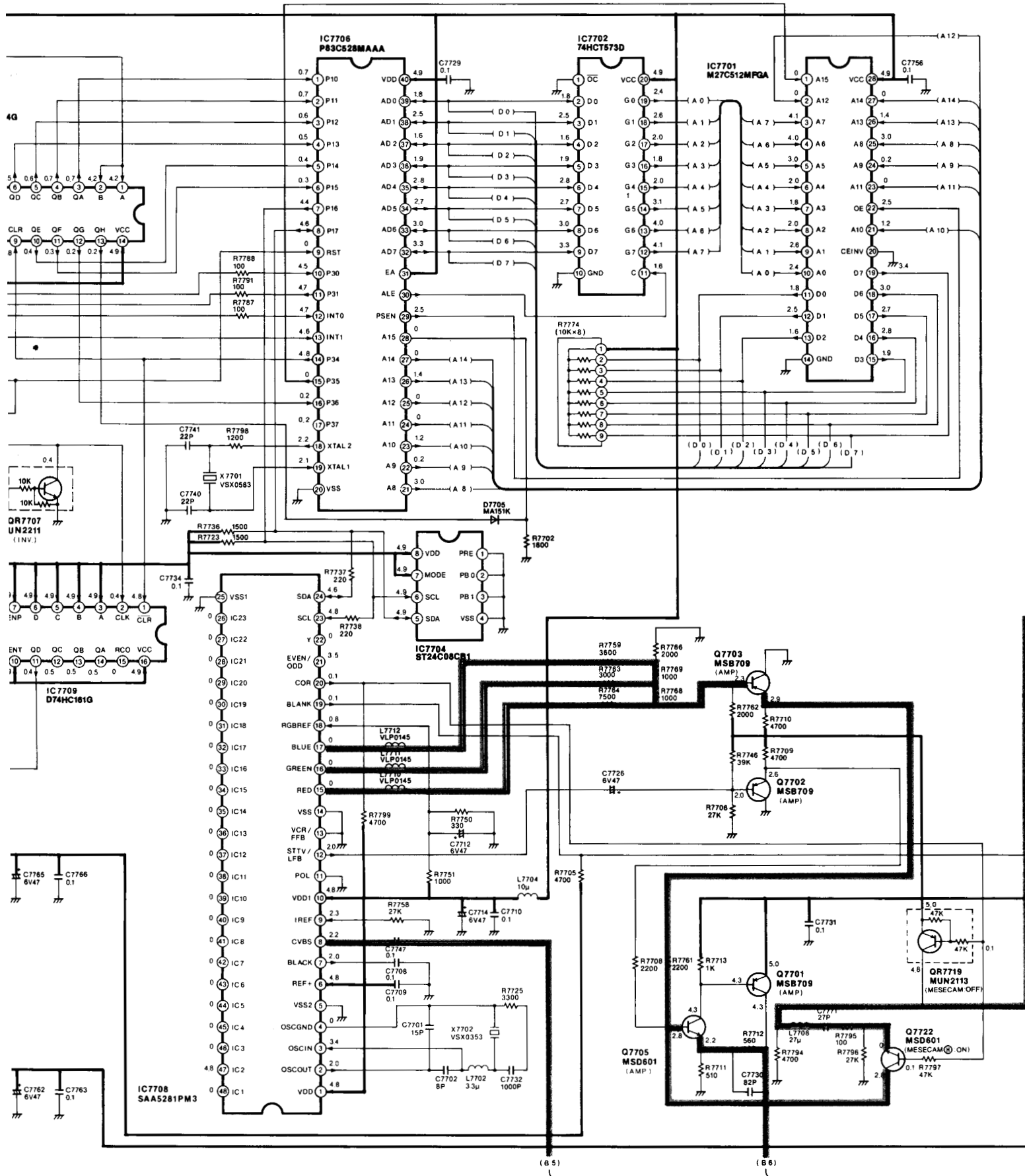

NOTE: THE MEASUREMENT MODE OF THE DC VOLTAGE ON THIS DIAGRAM IS STOP MODE.

4 | 5 | 6 | 7 | 8 | 9

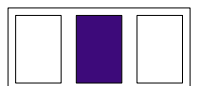

VIDEO MAIN SIGNAL PATH IN REC MODE  
 VIDEO MAIN SIGNAL PATH IN PLAYBACK MODE

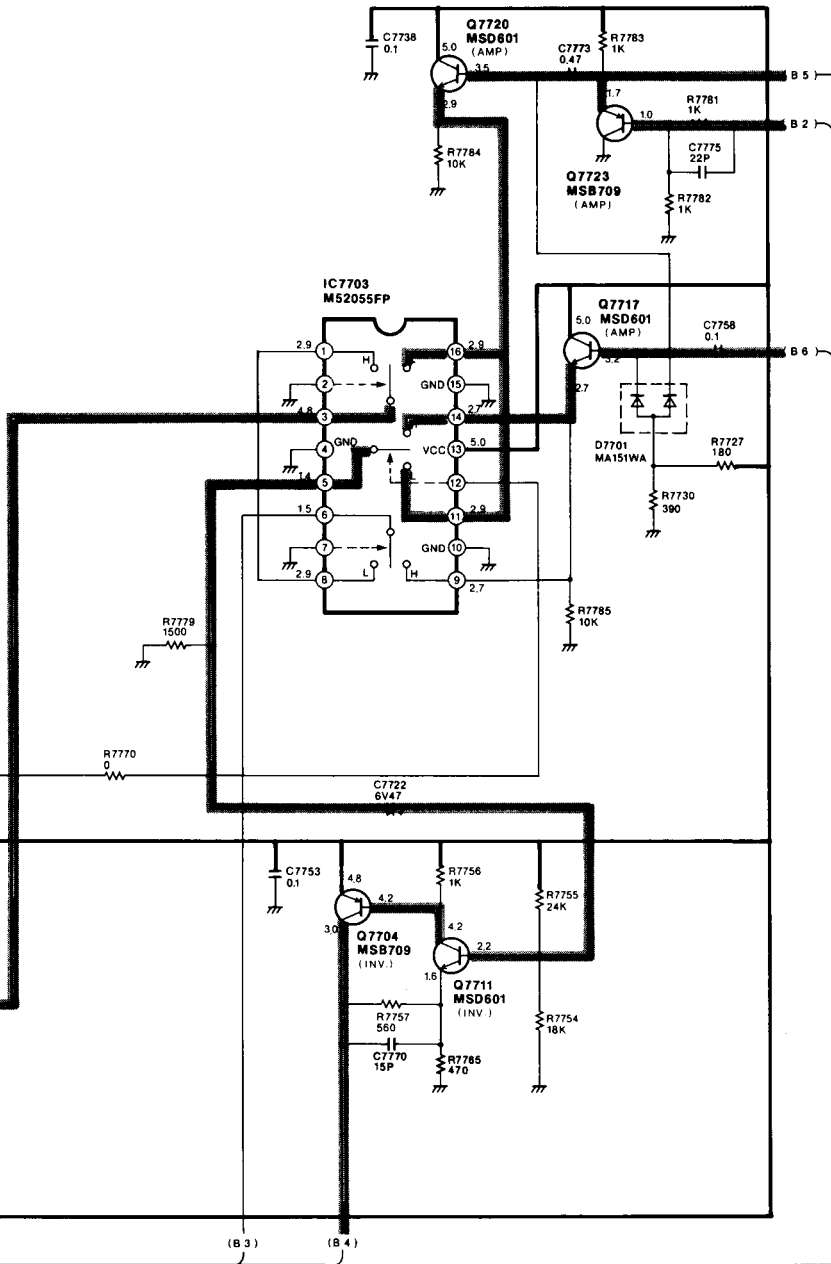
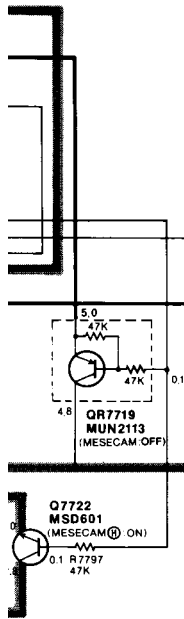
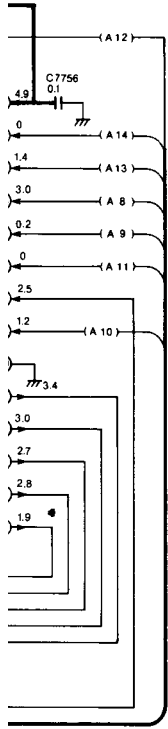

NOTE: DO NOT USE ANY PART NUMBER SHOWN ON THIS SCHEMATIC DIAGRAM FOR ORDERING. WHEN YOU ORDER A PART, PLEASE REFER TO PARTS LIST.

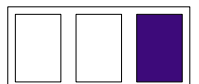

# 4-16. INPUT/OUTPUT PACK SCHEMATIC DIAGRAM (NV-HD650EE)

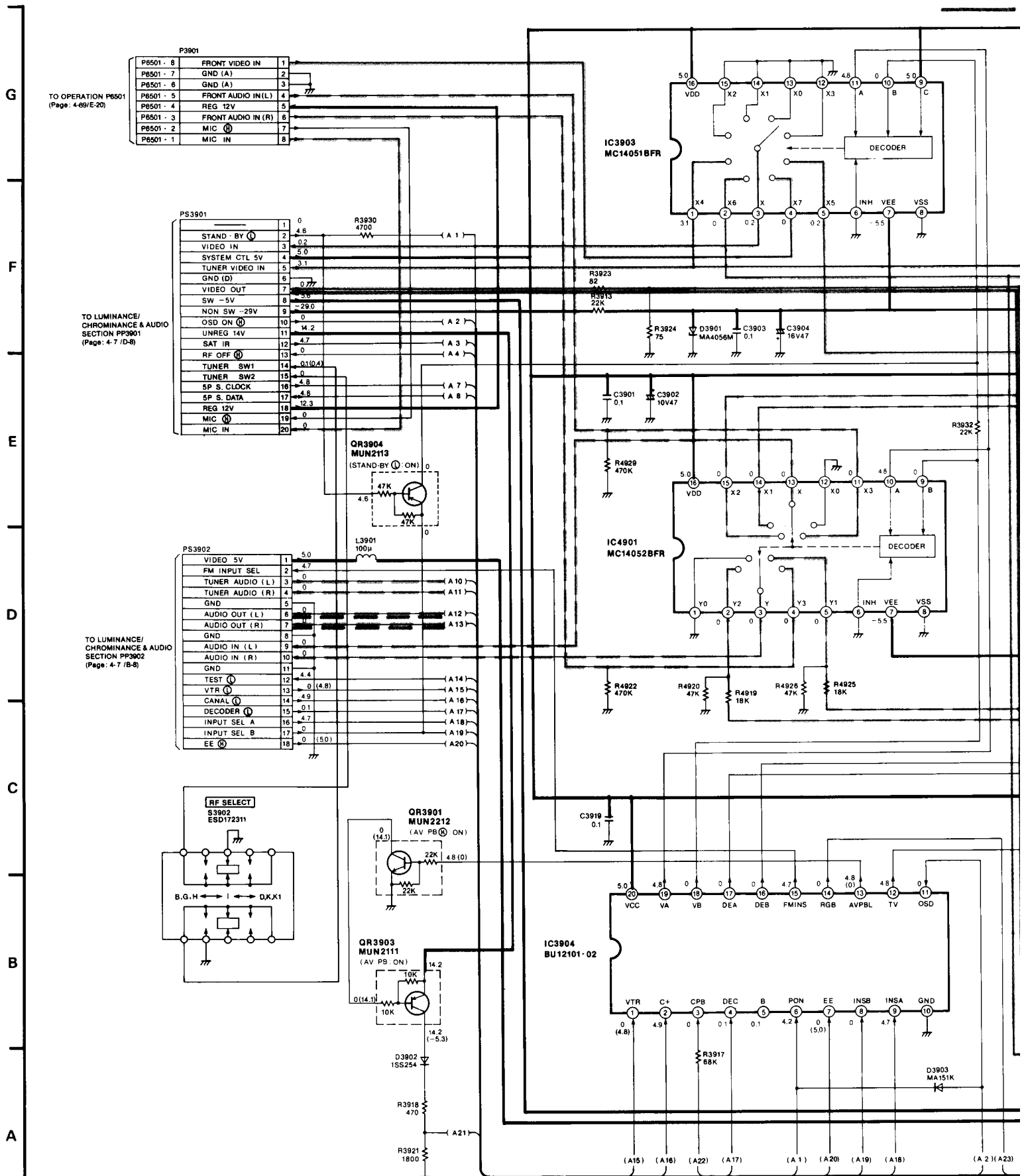

NOTE: THE MEASUREMENT MODE OF THE DC VOLTAGE IN THE BRACKETS ( ) ON THE WITH PAL COLOUR SIGNAL. (SP MODE)

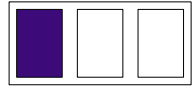



E)

VIDEO MAIN SIGNAL PATH IN REC MODE  
VIDEO MAIN SIGNAL PATH IN PLAYBACK MODE

AUDIO MAIN S  
AUDIO MAIN S

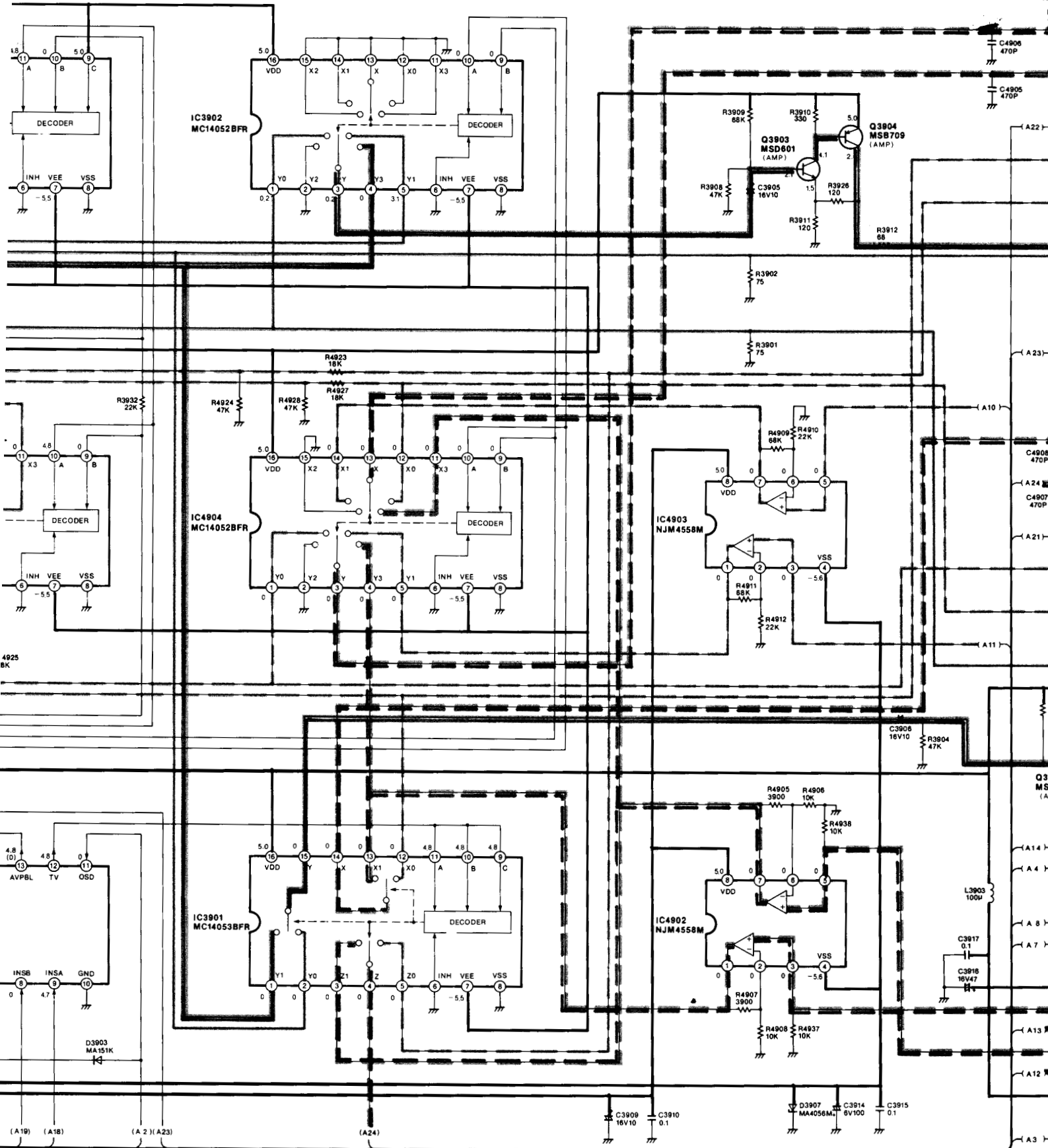

STAGE IN THE BRACKETS ( ) ON THIS DIAGRAM IS RECORD MODE

THE MEASUREMENT MODE OF THE DC VOLTAGE OUT OF THE BRACKETS ON THIS DIAGRAM IS PLAYBACK MODE WITH PAL COLOUR SIGNAL. (SP MODE)

6

7

8

9

10

11

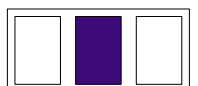

DE  
CK MODE

AUDIO MAIN SIGNAL PATH IN REC MODE  
 --- AUDIO MAIN SIGNAL PATH IN PLAYBACK MODE

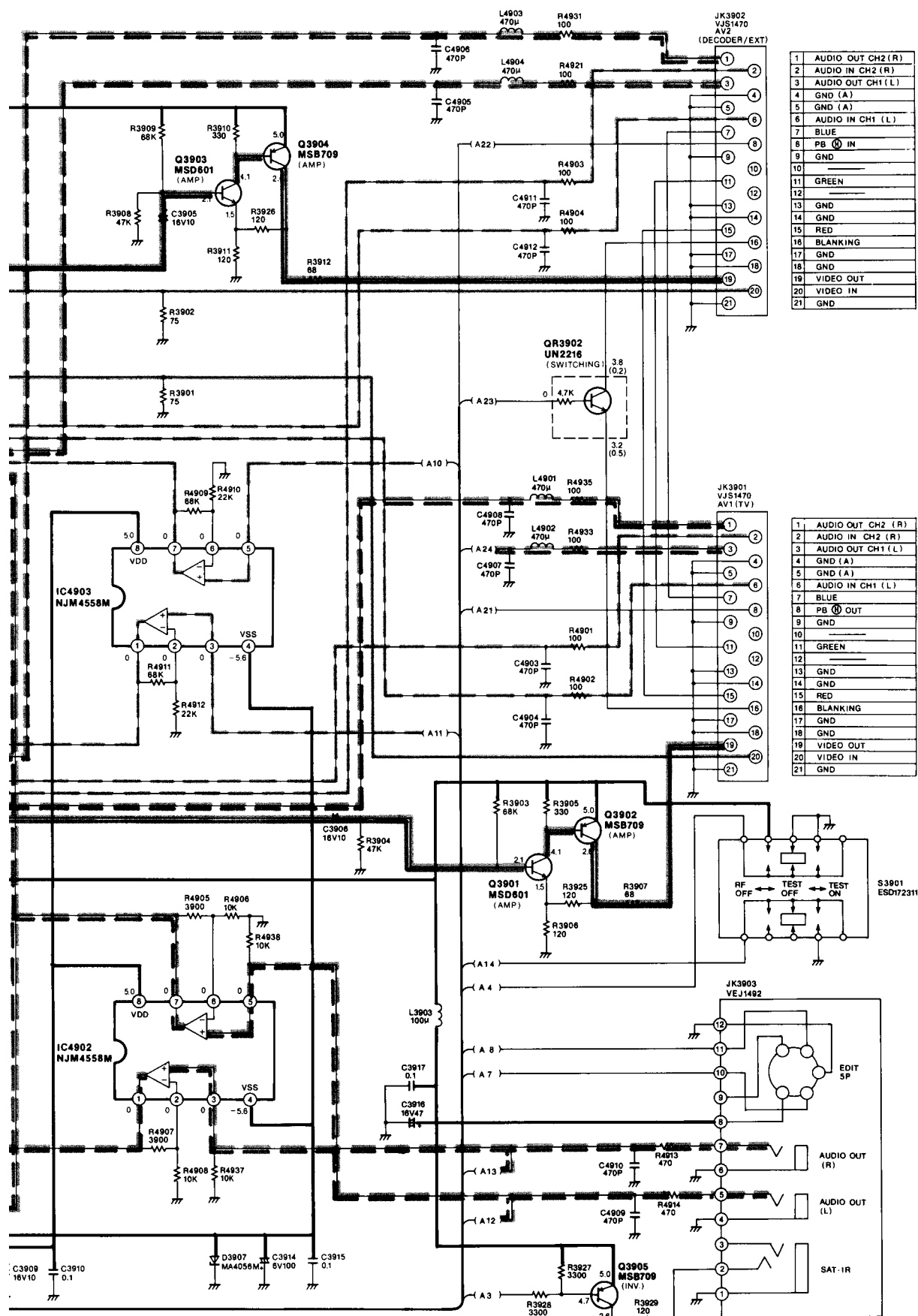

1	AUDIO OUT CH2 (R)
2	AUDIO IN CH2 (R)
3	AUDIO OUT CH1 (L)
4	GND (A)
5	GND (A)
6	AUDIO IN CH1 (L)
7	BLUE
8	PB IN
9	GND
10	
11	GREEN
12	
13	GND
14	GND
15	RED
16	BLANKING
17	GND
18	GND
19	VIDEO OUT
20	VIDEO IN
21	GND

1	AUDIO OUT CH2 (R)
2	AUDIO IN CH2 (R)
3	AUDIO OUT CH1 (L)
4	GND (A)
5	GND (A)
6	AUDIO IN CH1 (L)
7	BLUE
8	PB OUT
9	GND
10	
11	GREEN
12	
13	GND
14	GND
15	RED
16	BLANKING
17	GND
18	GND
19	VIDEO OUT
20	VIDEO IN
21	GND

IF THE BRACKETS ON THIS DIAGRAM IS PLAYBACK MODE

NOTE: DO NOT USE ANY PART NUMBER SHOWN ON THIS SCHEMATIC DIAGRAM FOR ORDERING. WHEN YOU ORDER A PART, PLEASE REFER TO PARTS LIST.

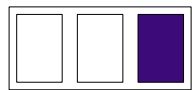

# 4-17. INPUT/OUTPUT PACK SCHEMATIC DIAGRAM(NV-H)

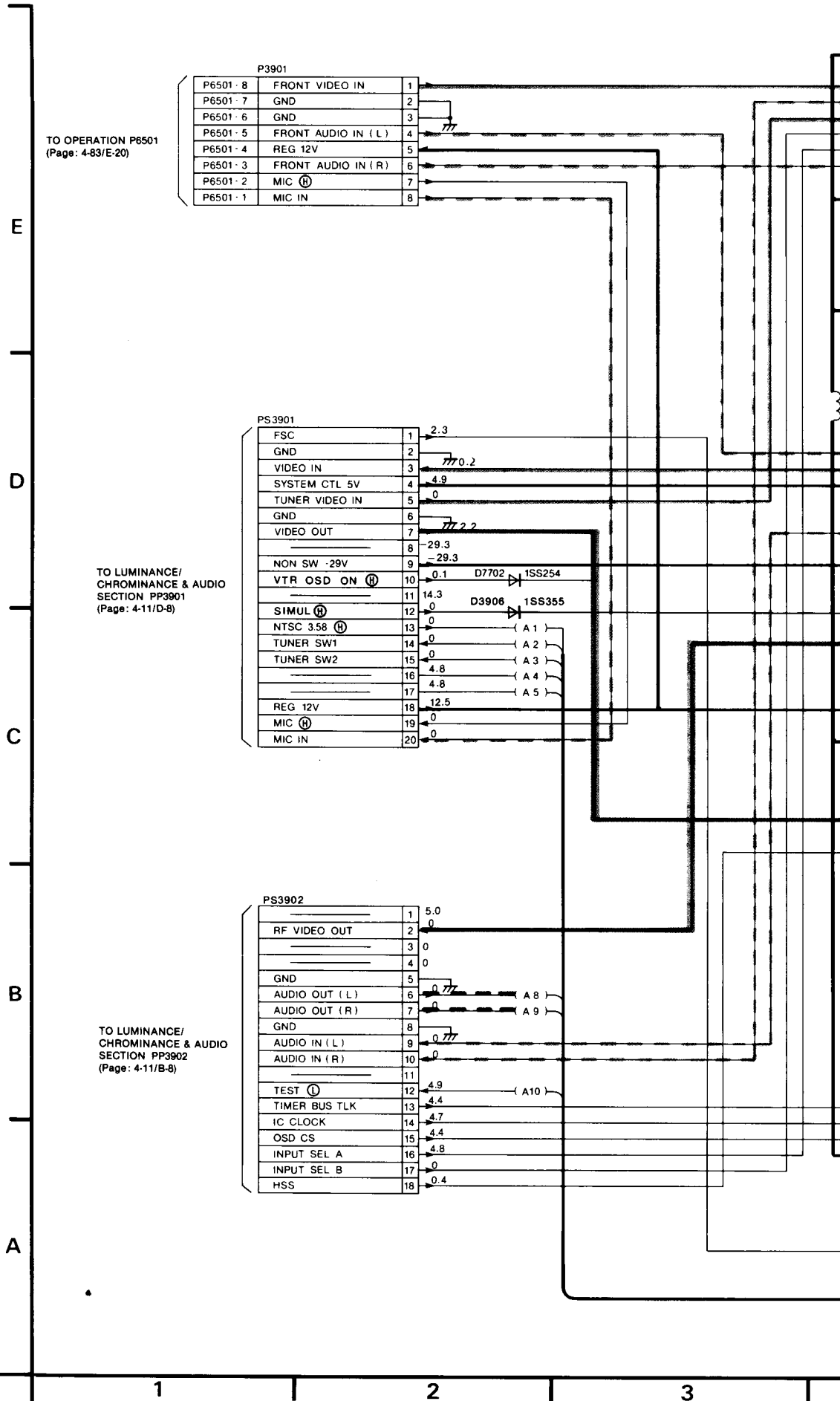

P3901

P6501-8	FRONT VIDEO IN	1
P6501-7	GND	2
P6501-6	GND	3
P6501-5	FRONT AUDIO IN ( L )	4
P6501-4	REG 12V	5
P6501-3	FRONT AUDIO IN ( R )	6
P6501-2	MIC (H)	7
P6501-1	MIC IN	8

TO OPERATION P6501  
(Page: 4-83/E-20)

PS3901

FSC	1	2.3
GND	2	
VIDEO IN	3	770.2
SYSTEM CTL 5V	4	4.9
TUNER VIDEO IN	5	0
GND	6	
VIDEO OUT	7	772.2
	8	-29.3
NON SW -29V	9	-29.3
VTR OSD ON (H)	10	0.1 D7702 1SS254
	11	14.3
SIMUL (H)	12	0 D3906 1SS355
NTSC 3.58 (H)	13	0 (A 1)
TUNER SW1	14	0 (A 2)
TUNER SW2	15	0 (A 3)
	16	4.8 (A 4)
	17	4.8 (A 5)
REG 12V	18	12.5
MIC (H)	19	0
MIC IN	20	0

TO LUMINANCE/  
CHROMINANCE & AUDIO  
SECTION PP3901  
(Page: 4-11/D-8)

PS3902

	1	5.0
RF VIDEO OUT	2	0
	3	0
	4	0
GND	5	
AUDIO OUT ( L )	6	0 777 (A 8)
AUDIO OUT ( R )	7	0 (A 9)
GND	8	
AUDIO IN ( L )	9	0 777
AUDIO IN ( R )	10	0
	11	
TEST (D)	12	4.9 (A 10)
TIMER BUS TLK	13	4.4
IC CLOCK	14	4.7
OSD CS	15	4.4
INPUT SEL A	16	4.8
INPUT SEL B	17	0
HSS	18	0.4

TO LUMINANCE/  
CHROMINANCE & AUDIO  
SECTION PP3902  
(Page: 4-11/B-8)

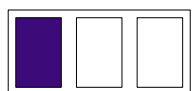

# GRAM(NV-HD650AM/BD,NV-HD655AM)

VIDEO MAIN SIGNAL PATH IN REC MODE

VIDEO MAIN SIGNAL PATH IN PLAYBACK MODE

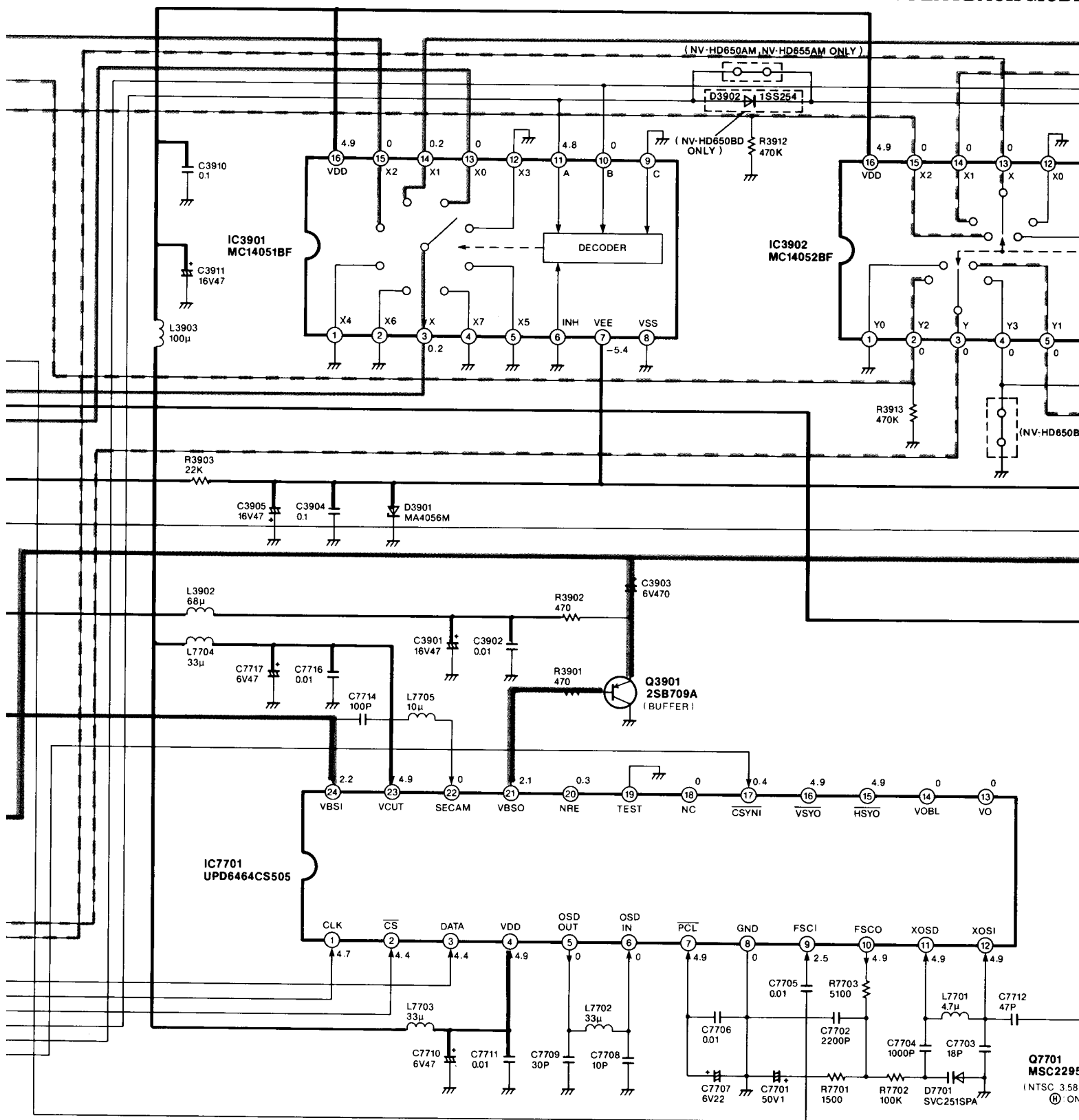

NOTE: THE MEASUREMENT MODE OF THE DC VOLTAGE IN THE BRACKETS ( ) ON THIS DIAGRAM IS RECORD MODE WITH PAL COLOUR SIGNAL. (SP MODE)  
 THE MEASUREMENT MODE OF THE DC VOLTAGE OUT OF THE BRACKETS ON THIS DIAGRAM IS PLAYBACK MODE WITH PAL COLOUR SIGNAL. (SP MODE)



H IN REC MODE  
H IN PLAYBACK MODE

--- AUDIO MAIN SIGNAL PATH IN REC MODE  
- - - AUDIO MAIN SIGNAL PATH IN PLAYBACK MODE

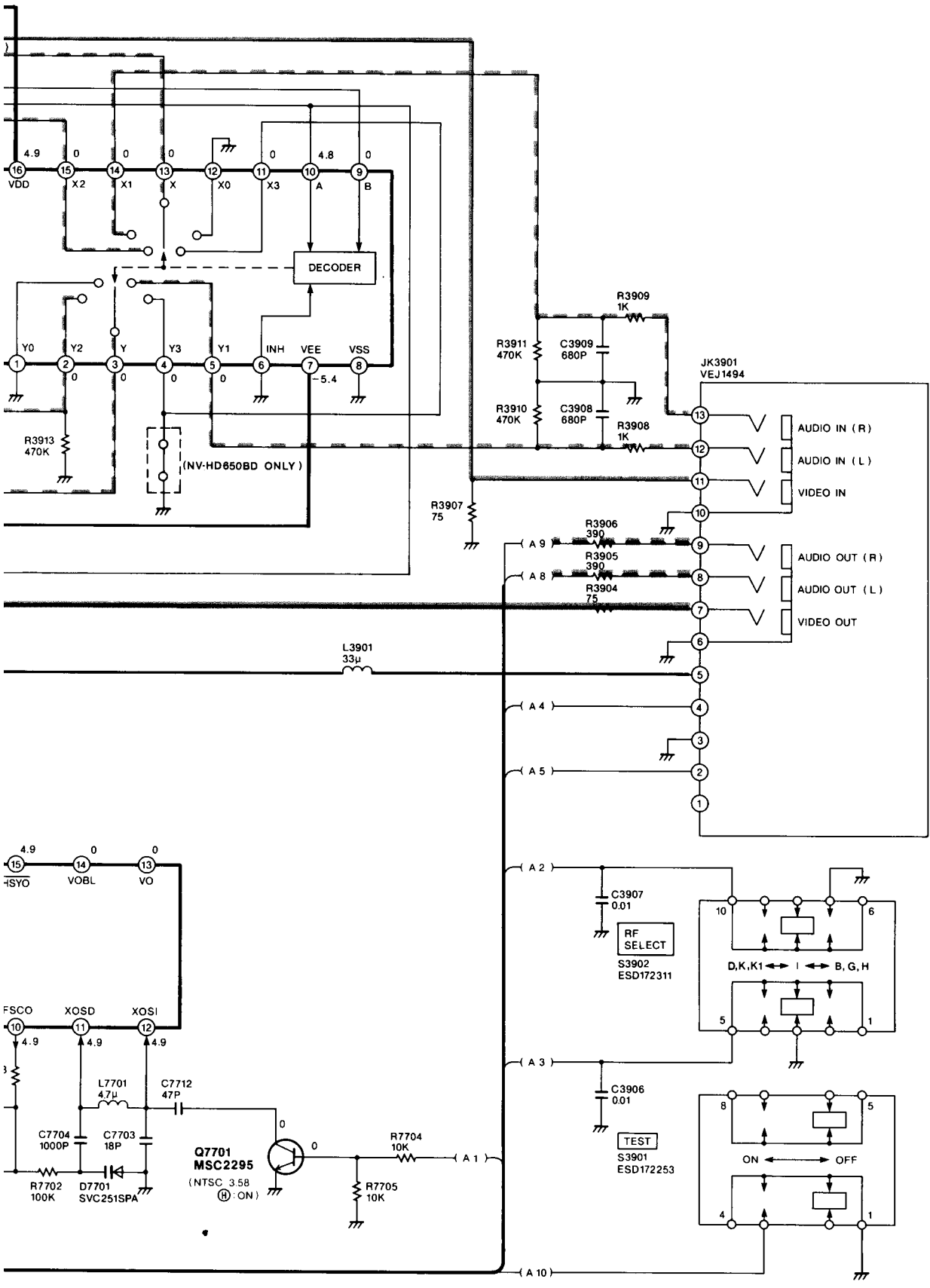

NOTE: DO NOT USE ANY PART NUMBER SHOWN ON THIS SCHEMATIC DIAGRAM FOR ORDERING. WHEN YOU ORDER A PART, PLEASE REFER TO PARTS LIST.

7 | 8 | 9 | 10

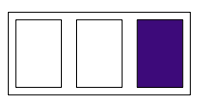

# 4-19. HEAD AMP SCHEMATIC DIAGRAM

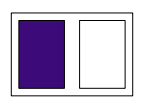
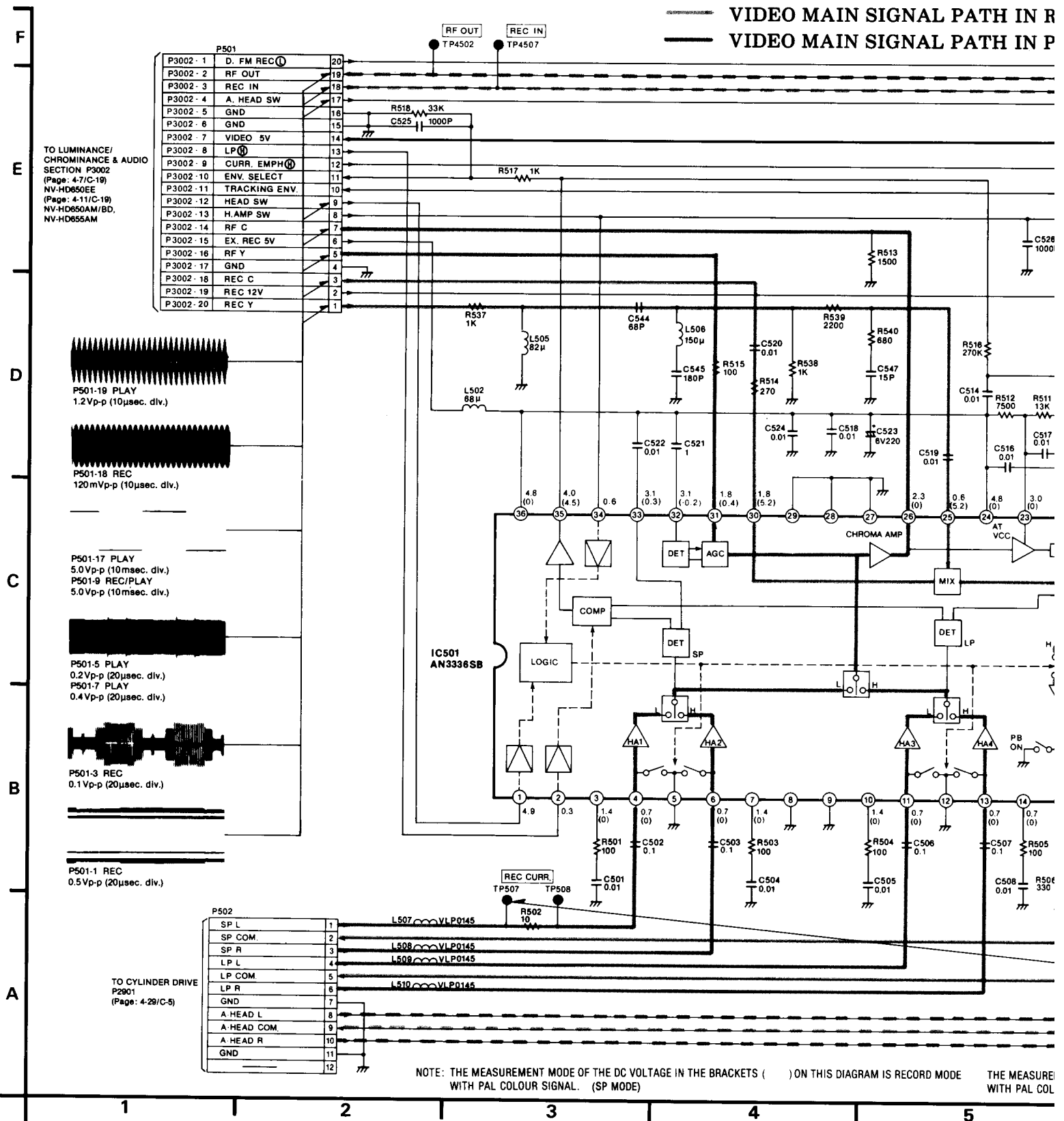

IN REC MODE

----- Hi-Fi AUDIO MAIN SIGNAL PATH IN REC MODE

IN PLAYBACK MODE

--- Hi-Fi AUDIO MAIN SIGNAL PATH IN PLAYBACK MODE

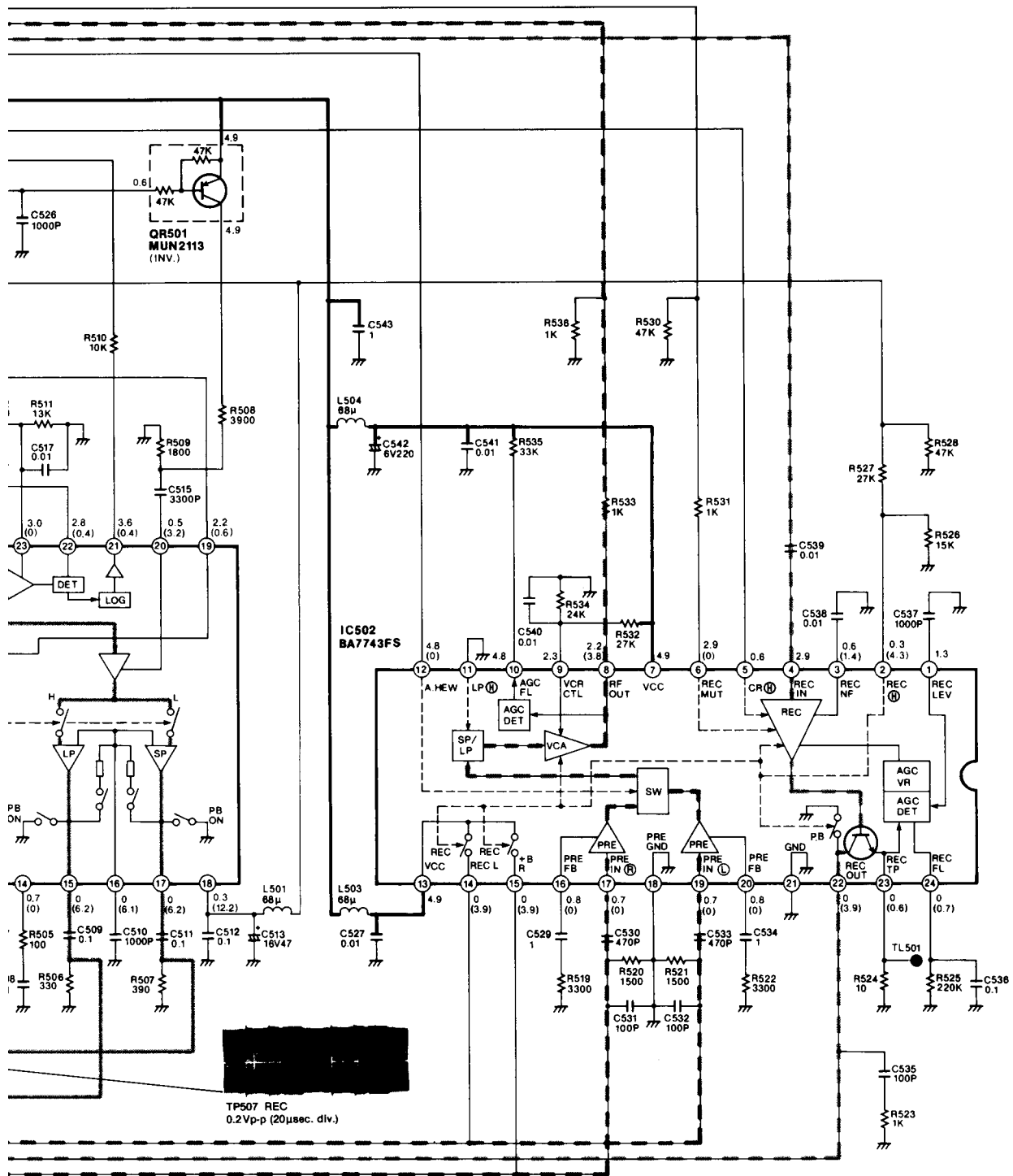

MEASUREMENT MODE OF THE DC VOLTAGE OUT OF THE BRACKETS ON THIS DIAGRAM IS PLAYBACK MODE  
PAL COLOUR SIGNAL. (SP MODE)

NOTE: DO NOT USE ANY PART NUMBER SHOWN ON THIS SCHEMATIC DIAGRAM FOR ORDERING. WHEN YOU ORDER A PART, PLEASE REFER TO PARTS LIST.

6

7

8

9

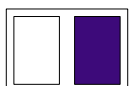

# 4-21. LUMINANCE & CHROMINANCE PACK SCHEMATIC DIAGRAM

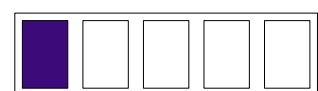
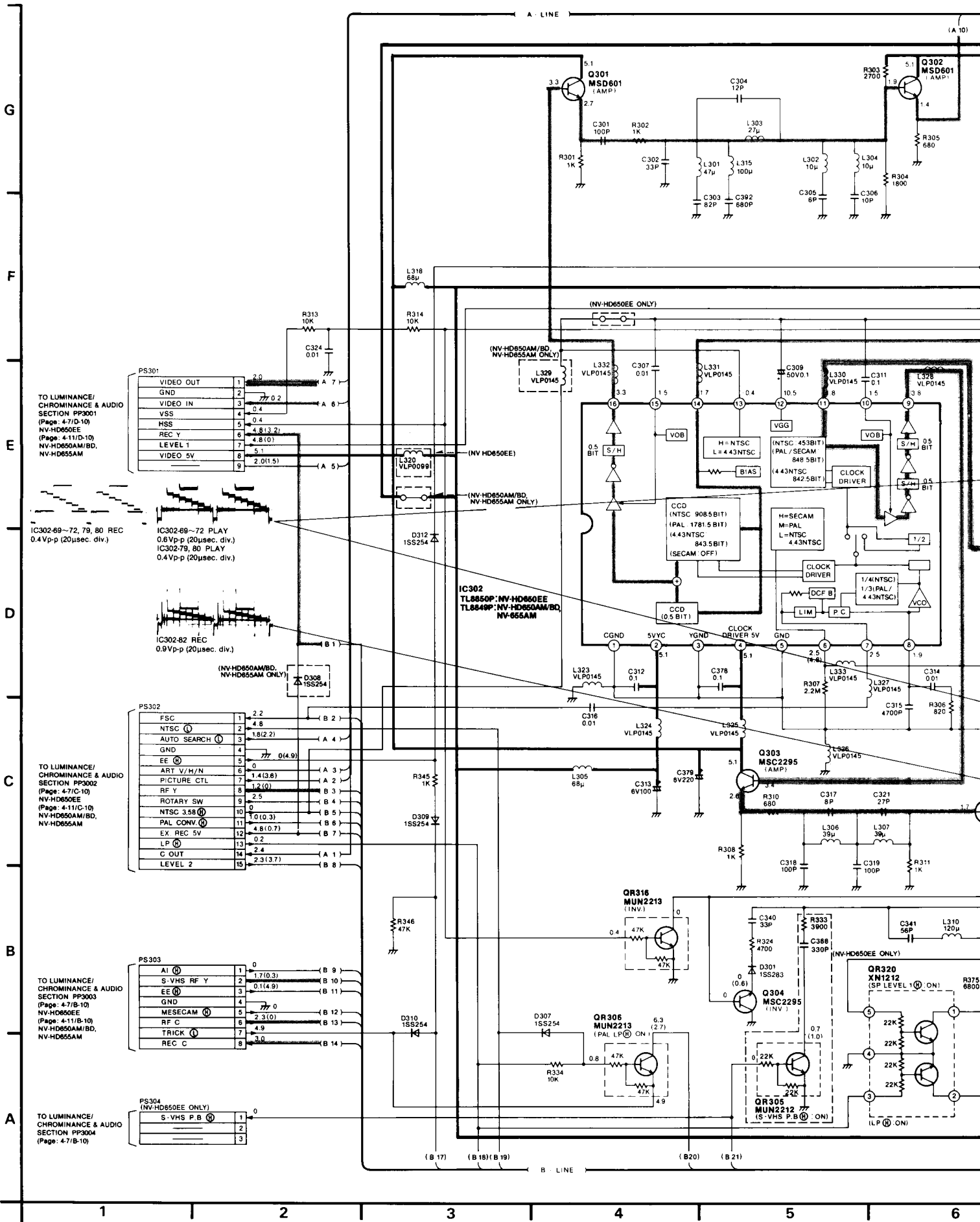

**MATIC DIAGRAM**

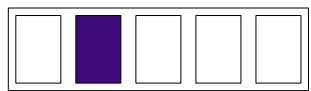
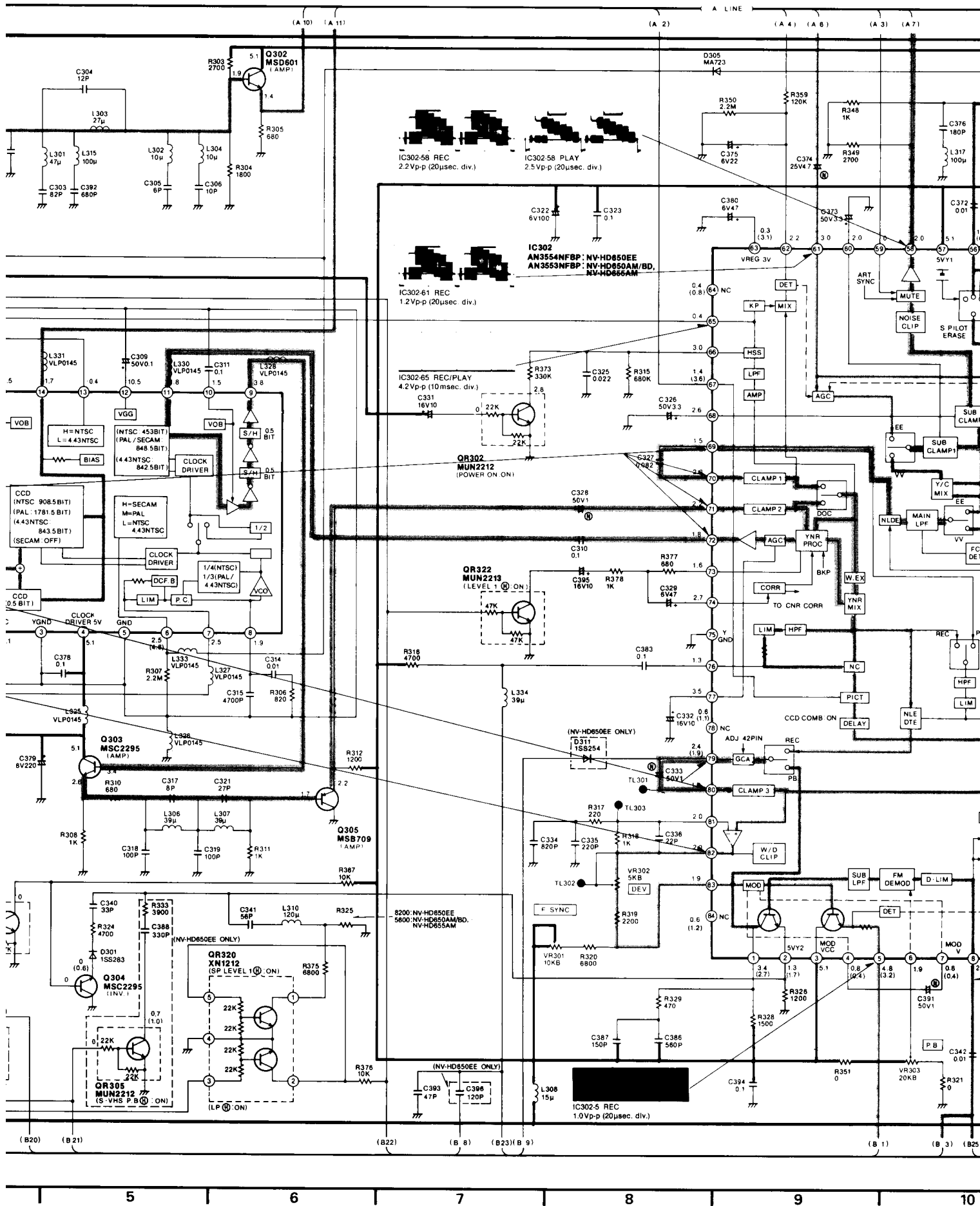



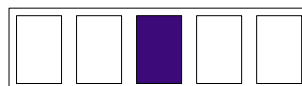
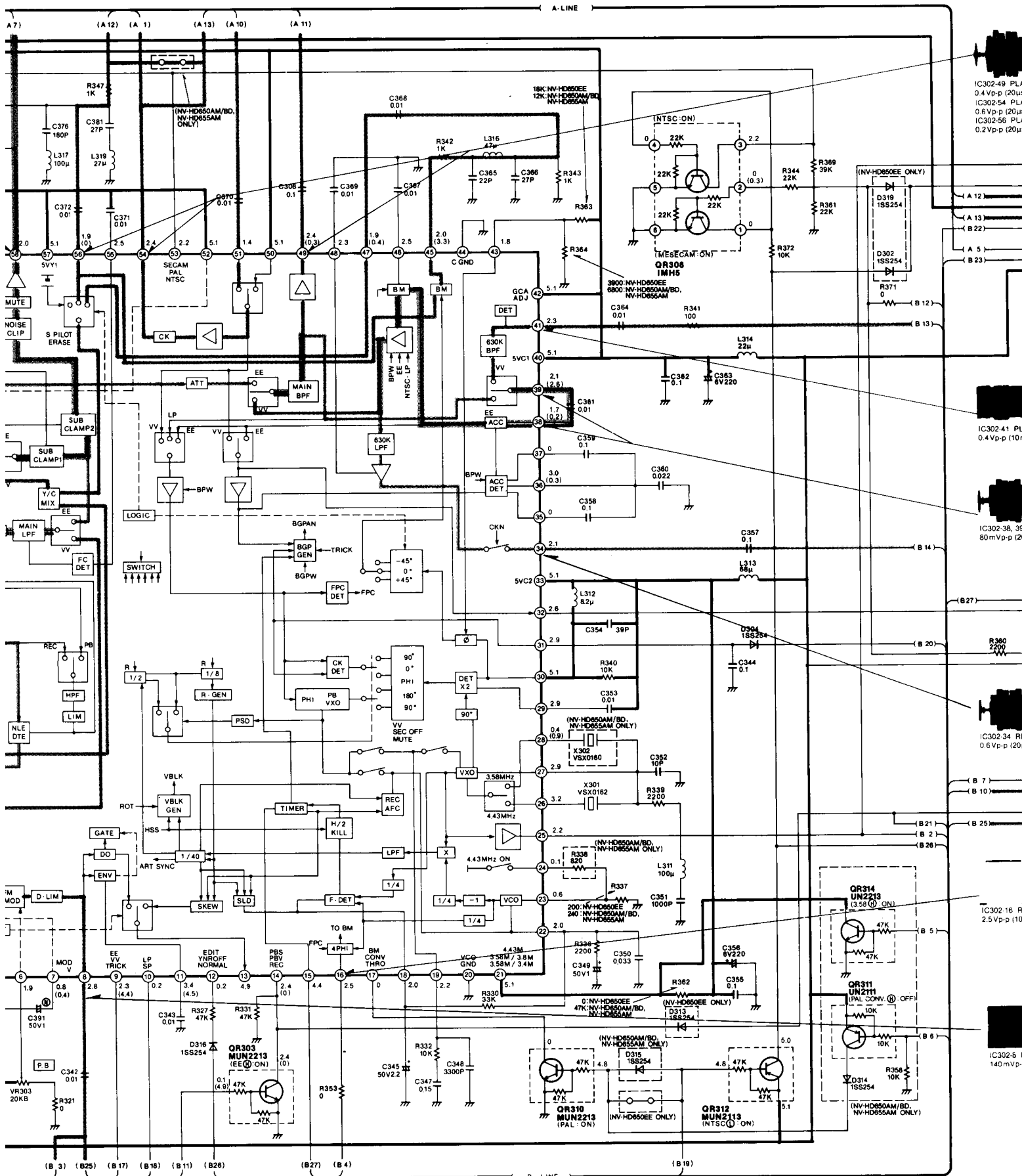

**MAIN SIGNAL PATH IN REC**  
**MAIN SIGNAL PATH IN PLAY**



IC302-49 PLAY  
0.4Vp-p (20µsec. div.)  
 IC302-54 PLAY  
0.8Vp-p (20µsec. div.)  
 IC302-56 PLAY  
0.2Vp-p (20µsec. div.)

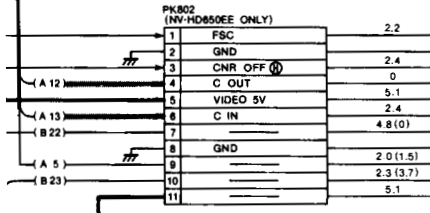

IC302-41 PLAY  
0.4Vp-p (10msec. div.)

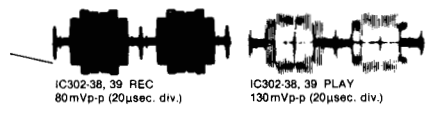

IC302-38, 39 REC  
80mVp-p (20µsec. div.)

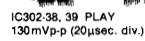

IC302-38, 39 PLAY  
130mVp-p (20µsec. div.)

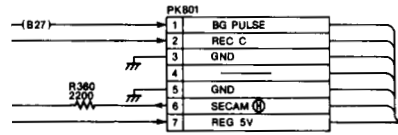

IC302-34 REC  
0.6Vp-p (20µsec. div.)

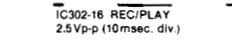
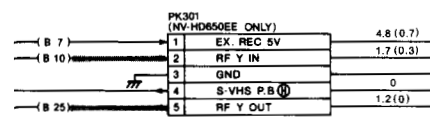

IC302-16 REC/PLAY  
2.5Vp-p (10msec. div.)



IC302-5 PLAY  
140mVp-p (20µsec. div.)

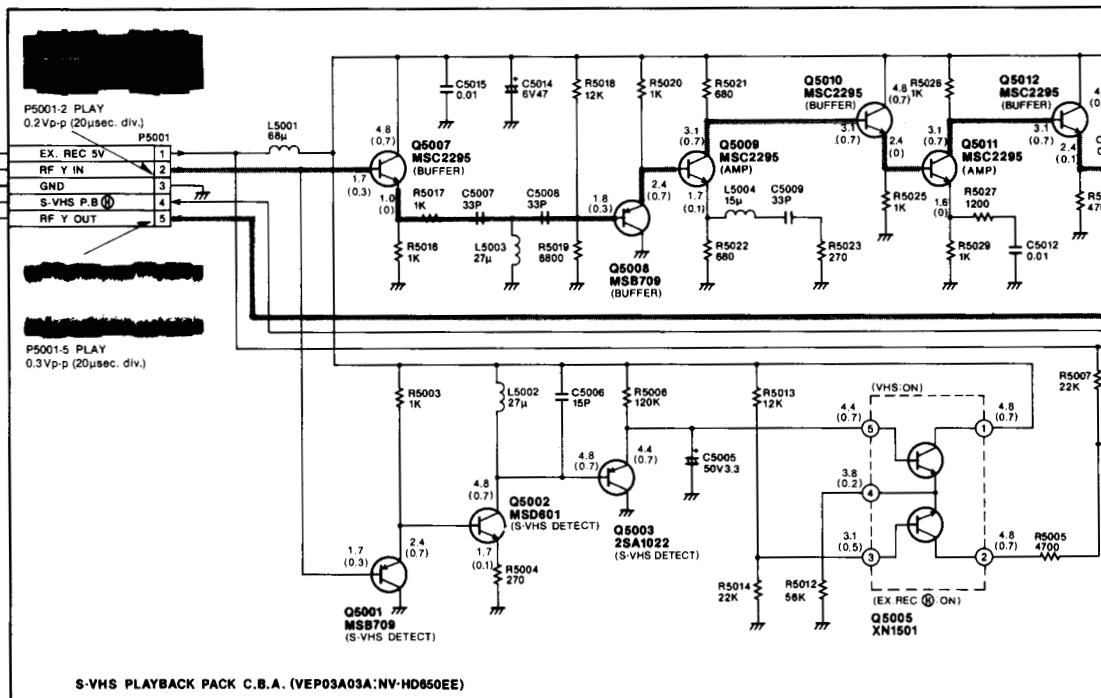
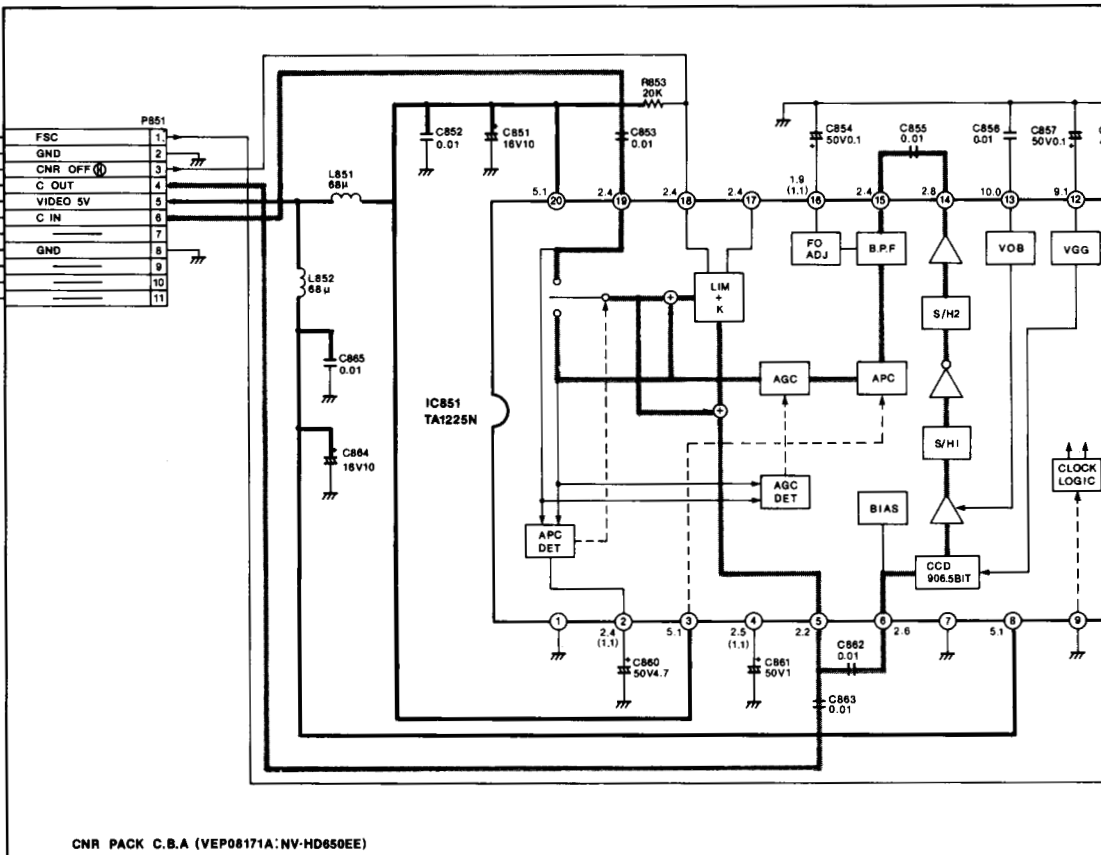

NOTE: THE MEASUREMENT MODE OF THE DC VOLTAGE IN THE BRACKETS ( ) ON THIS DIAGRAM IS RECORD MODE WITH PAL COLOUR SIGNAL. (SP MODE)  
 THE MEASUREMENT MODE OF THE DC VOLTAGE OUT OF THE BRACKETS ON THIS DIAGRAM IS PLAYBACK MODE WITH PAL COLOUR SIGNAL. (SP MODE)

NOTE: DO NOT USE ANY PARTS FROM THIS SCHEMATIC DIAGRAM TO ORDER A PART, PLEASE



**PATH IN REC MODE**  
**PATH IN PLAYBACK MODE**

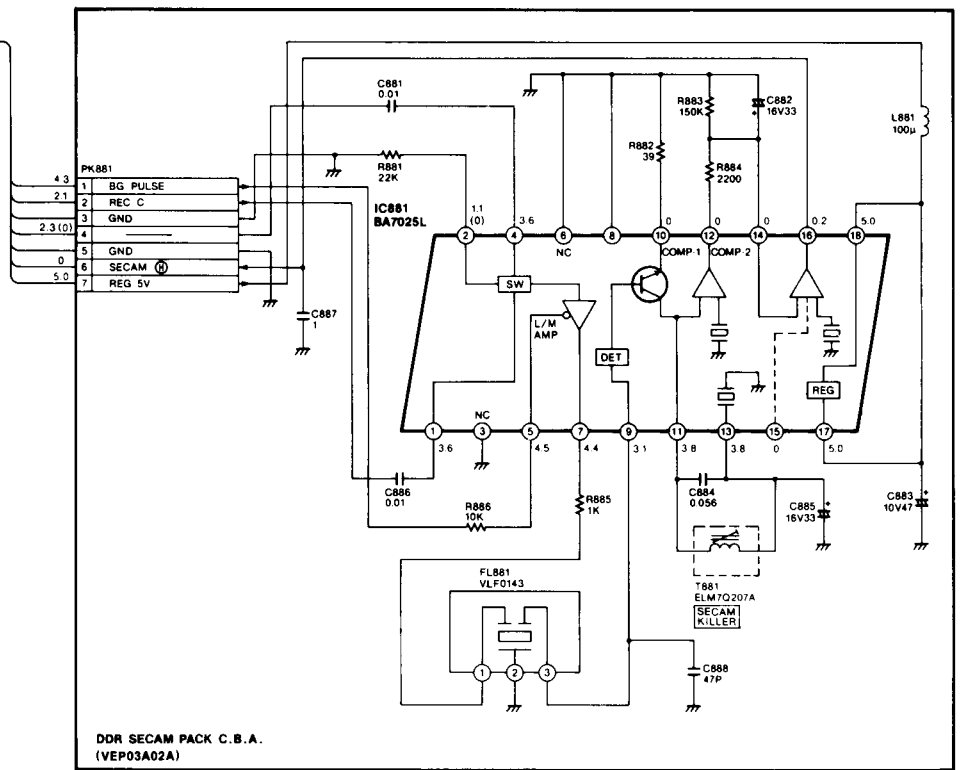
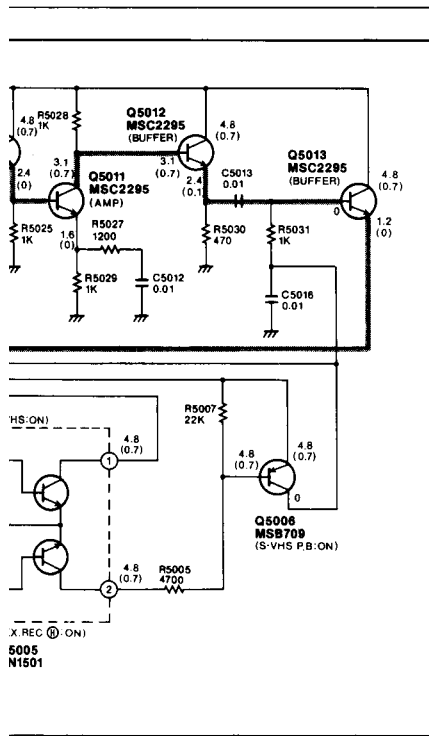
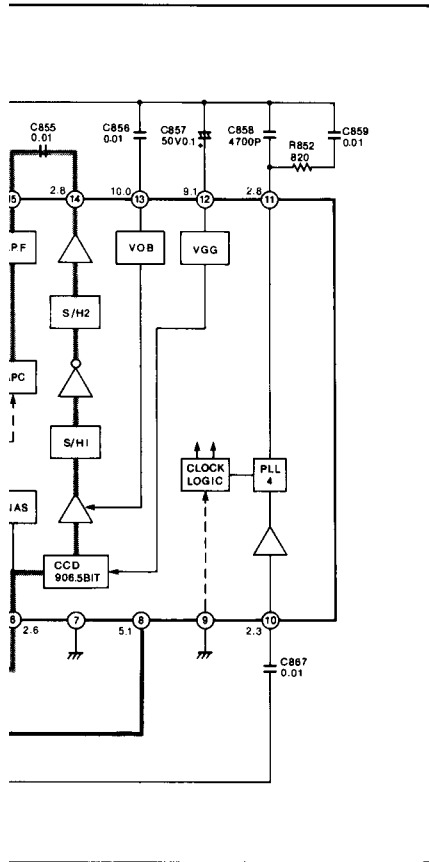

DDR SECAM PACK C.B.A.  
 (VEP03A02A)

NOTE: DO NOT USE ANY PART NUMBER SHOWN ON THIS SCHEMATIC DIAGRAM FOR ORDERING. WHEN YOU ORDER A PART, PLEASE REFER TO PARTS LIST.

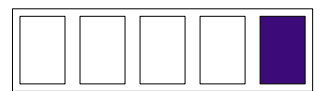

4-23. TIMER & OPERATION SCHEMATIC DIAGRAM (NV-HD650EE)

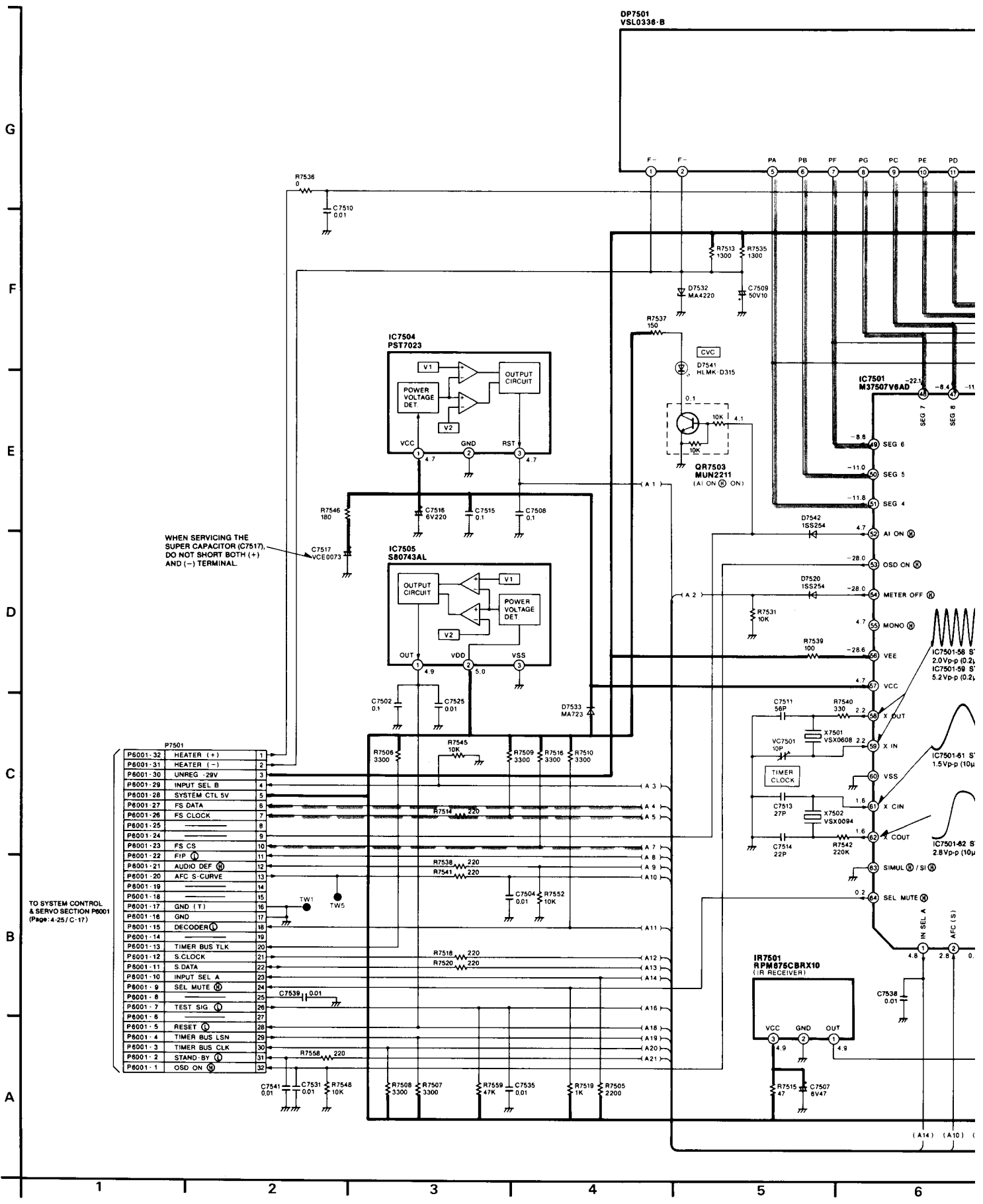

WHEN SERVICING THE SUPER CAPACITOR (C7517), DO NOT SHORT BOTH (+) AND (-) TERMINAL.

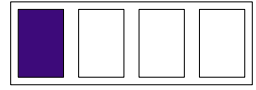

EE)

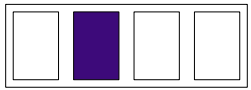
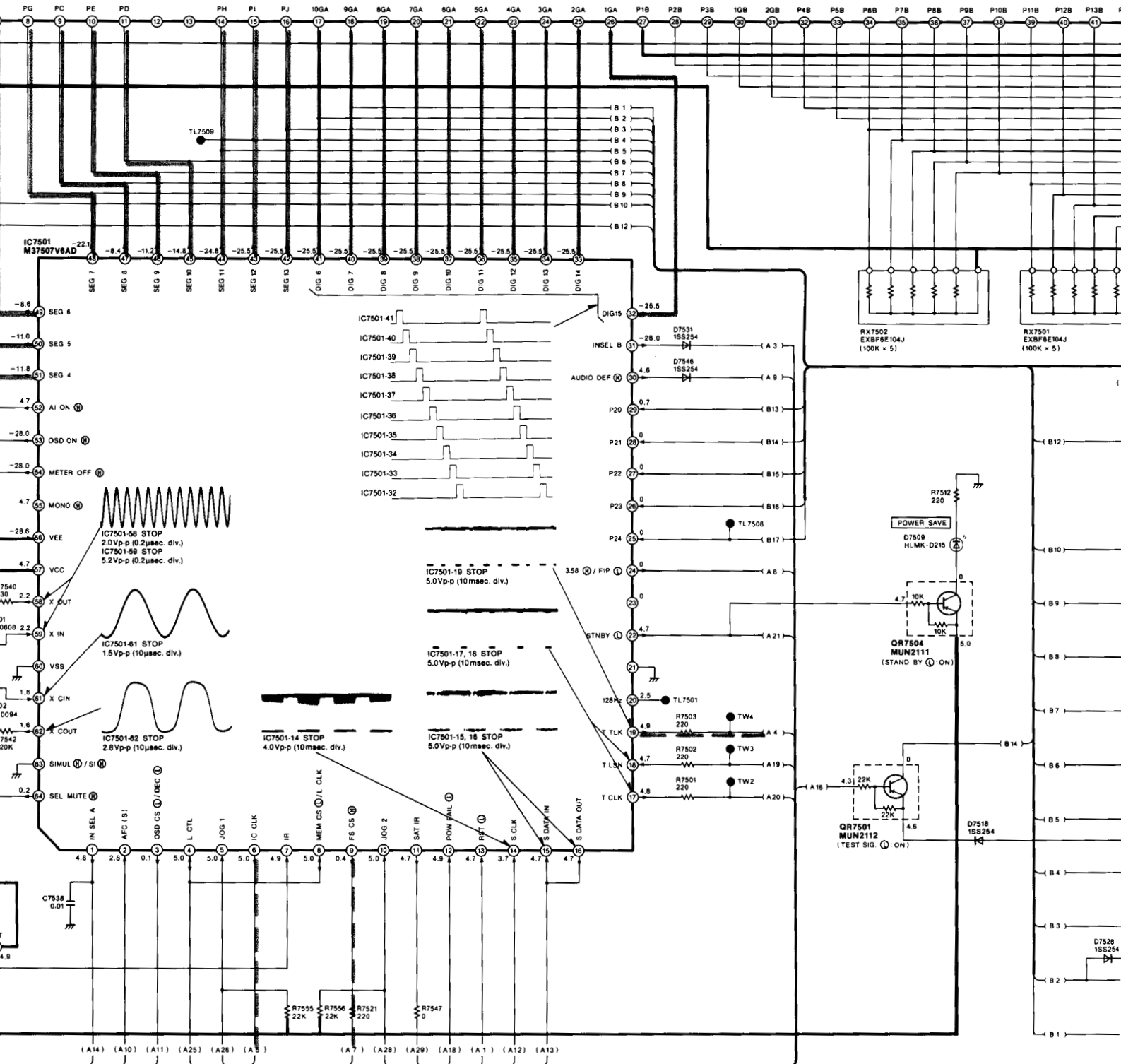
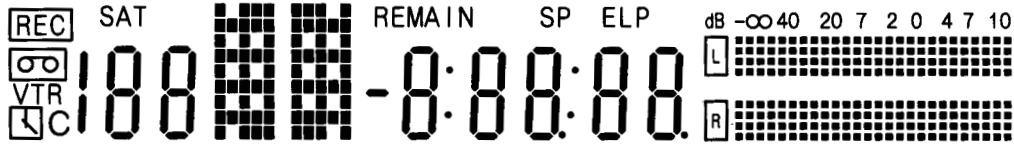



SEGMENT CONTROL SIGNAL

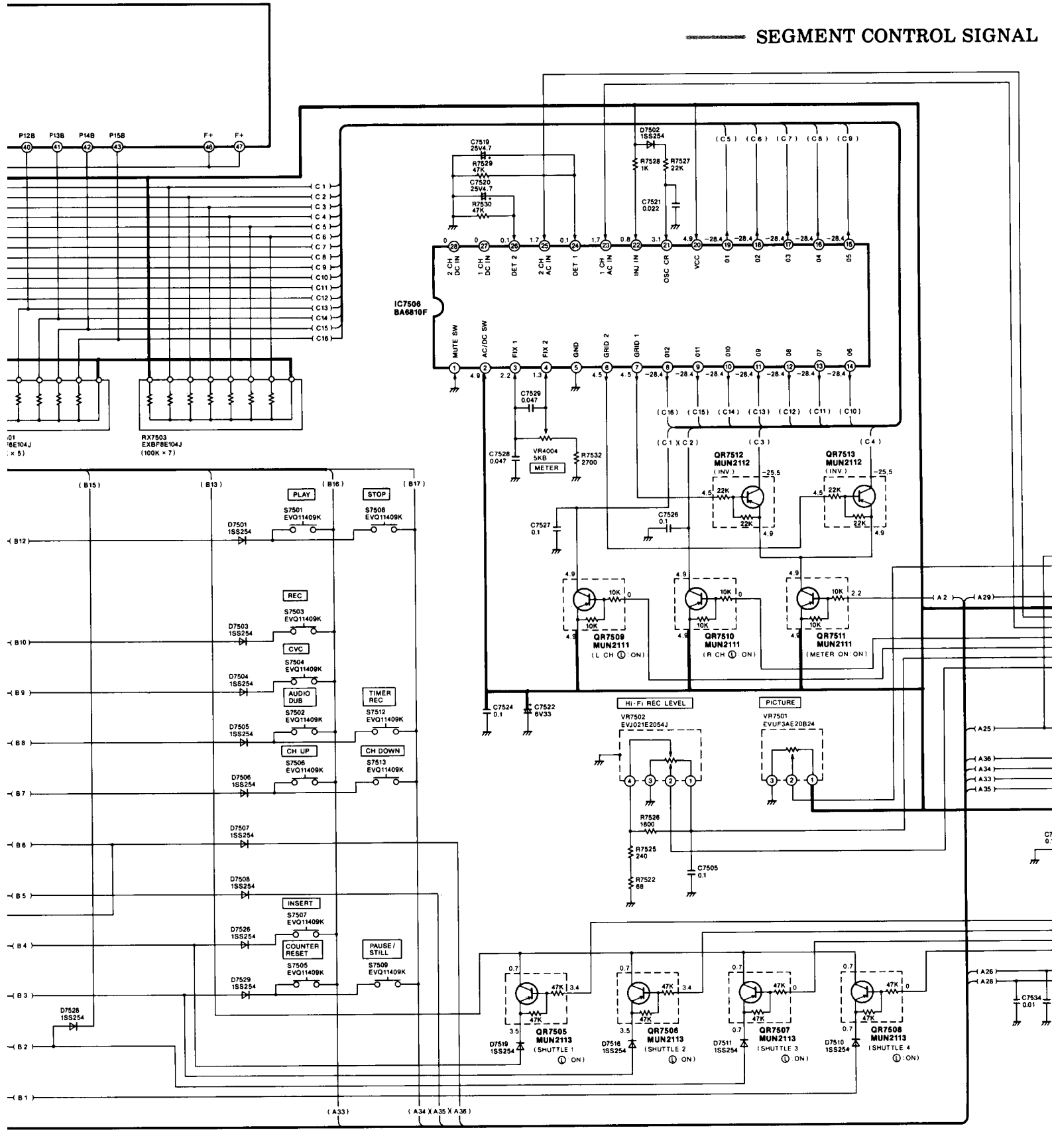

12

13

14

15

16

17

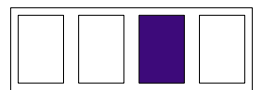

GNAL ——— GRID CONTROL SIGNAL TUNE CONTROL SIGNAL

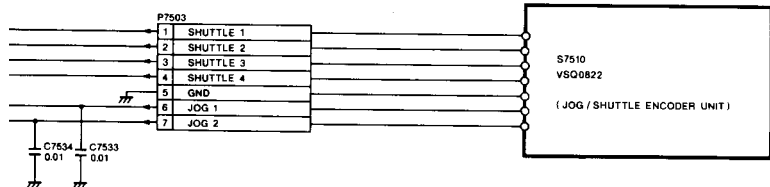
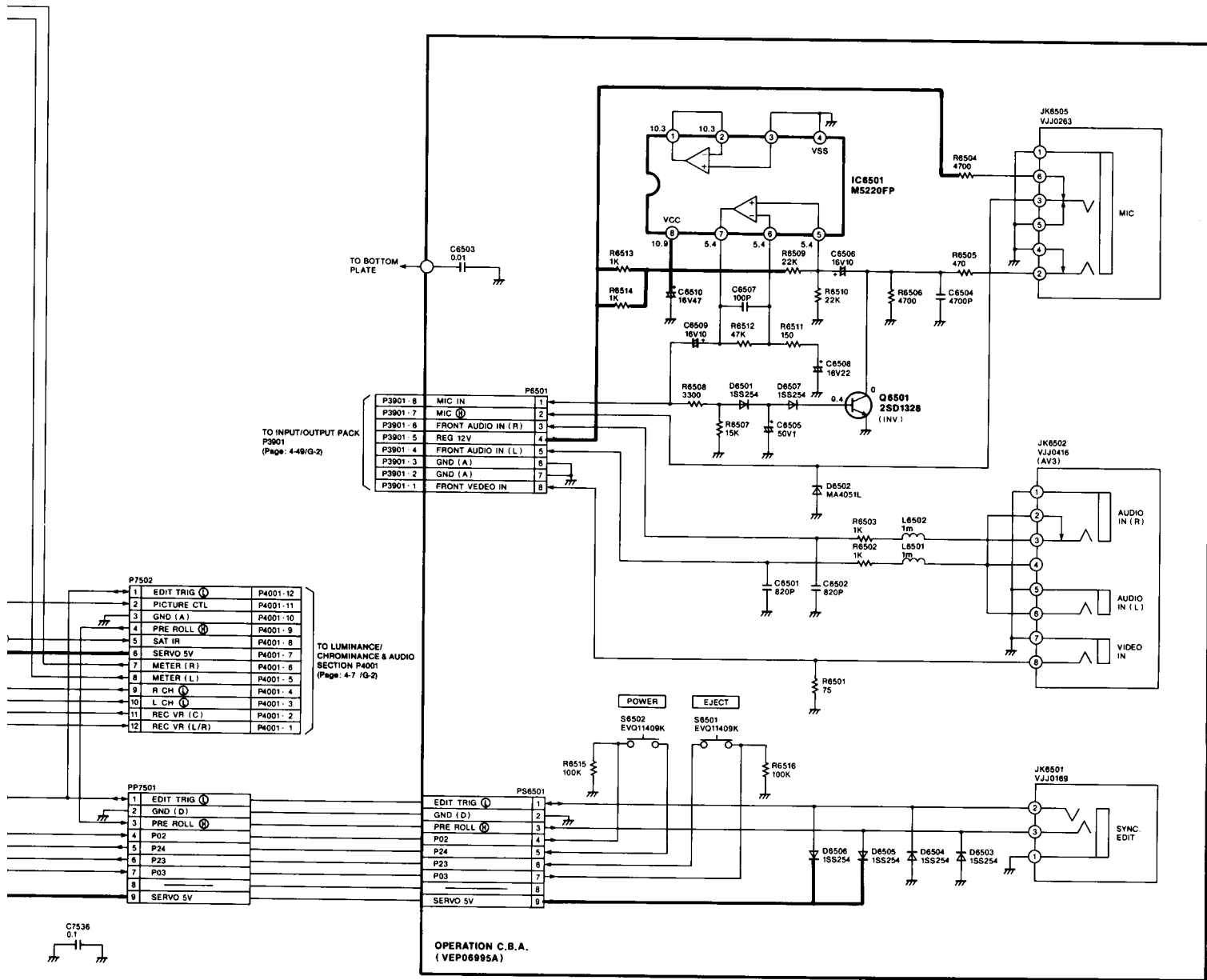

NOTE: THE MEASUREMENT MODE OF THE DC VOLTAGE ON THIS DIAGRAM IS STOP MODE.

NOTE: DO NOT USE ANY PART NUMBER SHOWN ON THIS SCHEMATIC DIAGRAM FOR ORDERING. WHEN YOU ORDER A PART, PLEASE REFER TO PARTS LIST.

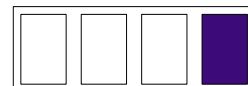

# 4-26. TIMER & OPERATION SCHEMATIC DIAGRAM (NV-HD650AM/BD, NV-HD650BM/BD)

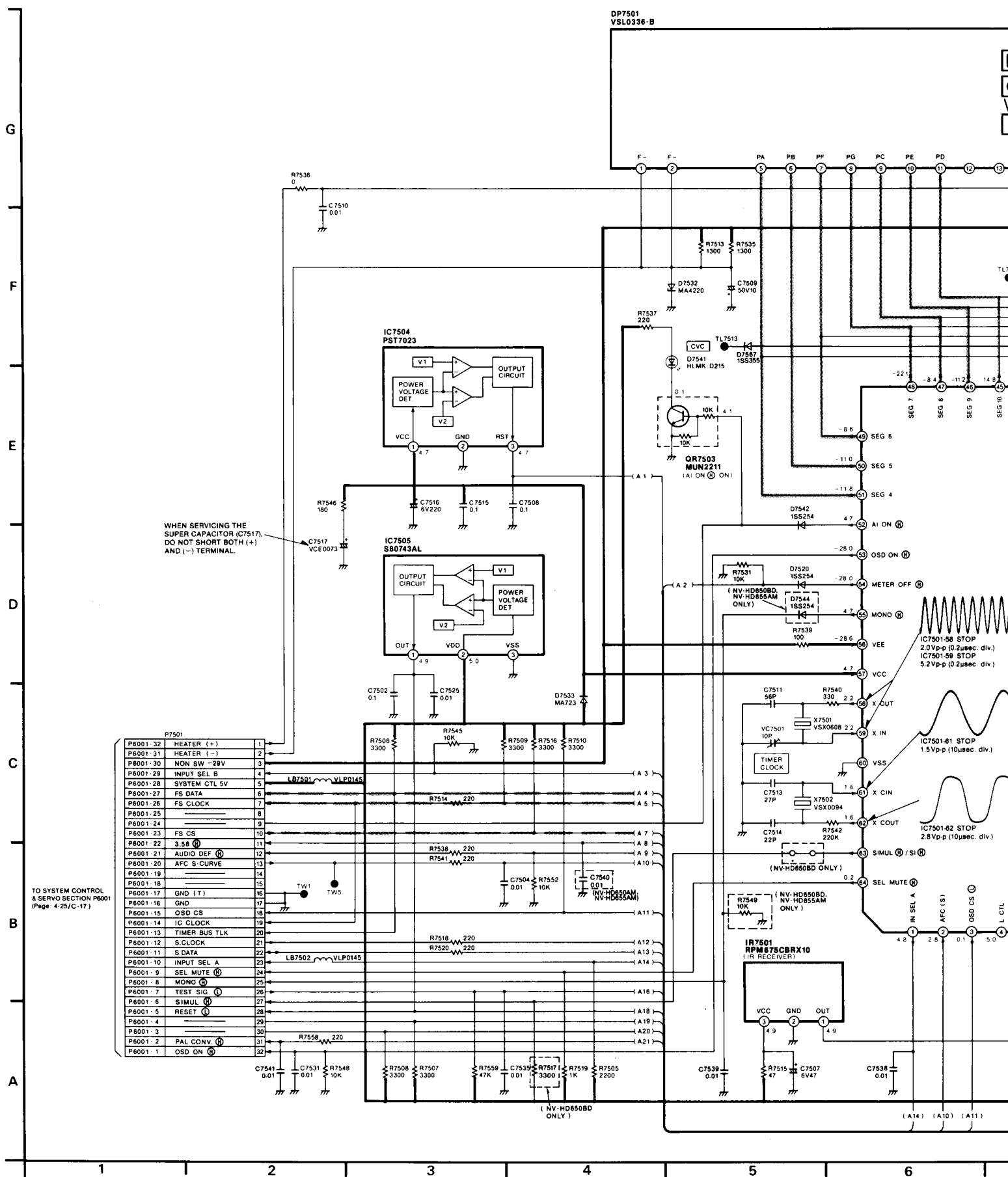

WHEN SERVICING THE SUPER CAPACITOR (C7517), DO NOT SHORT BOTH (+) AND (-) TERMINAL.

TO SYSTEM CONTROL & SERVO SECTION P6001 (Page 4-25/C-17)

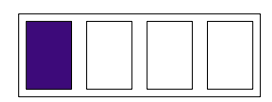
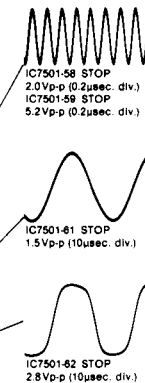

# BD,NV-HD655AM)

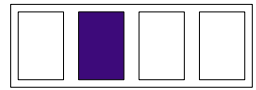
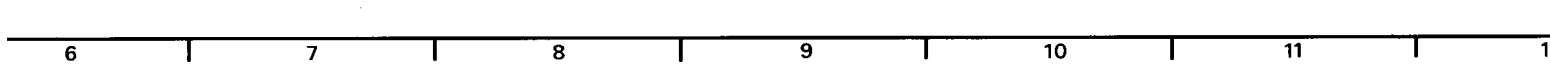
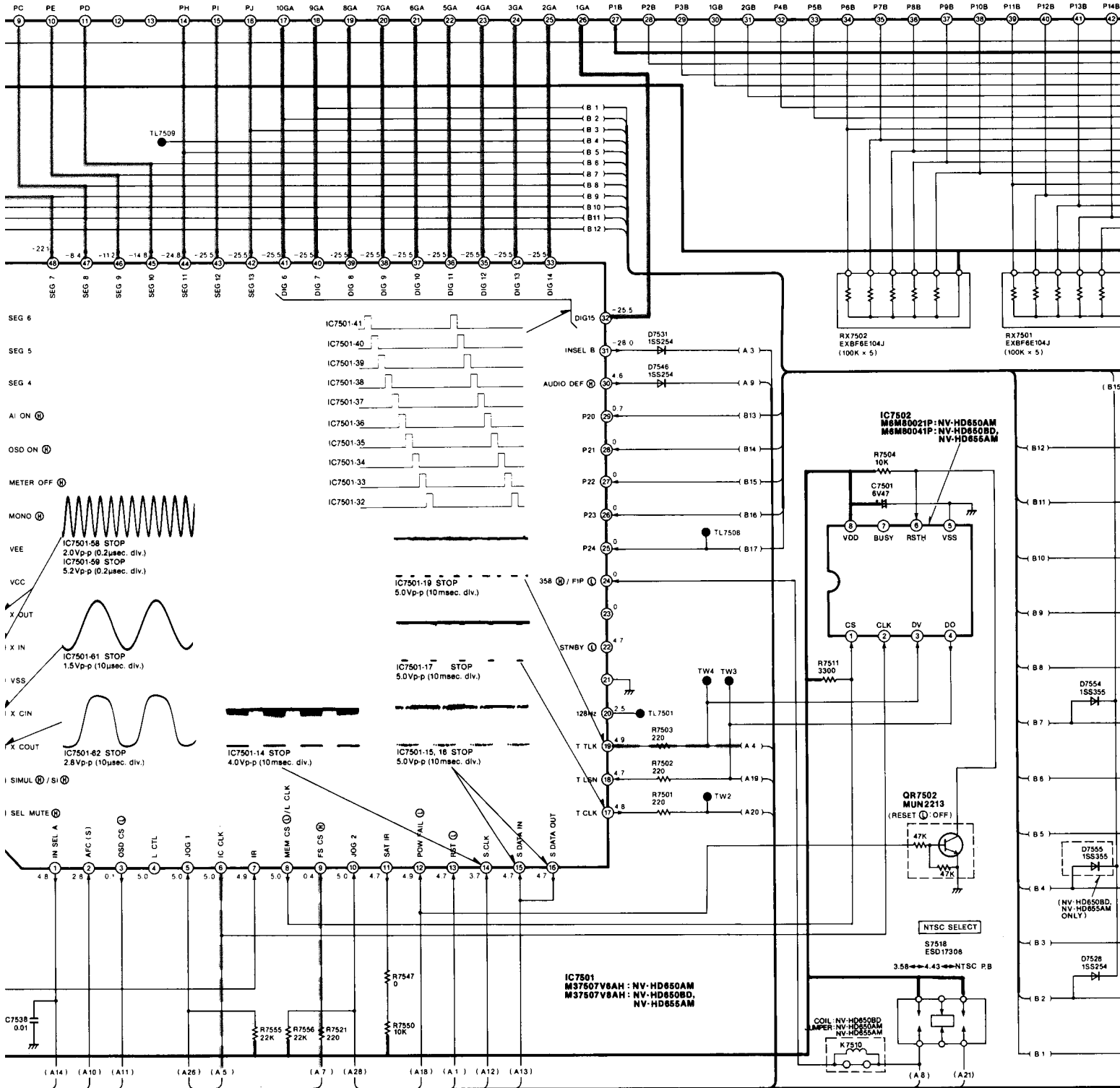
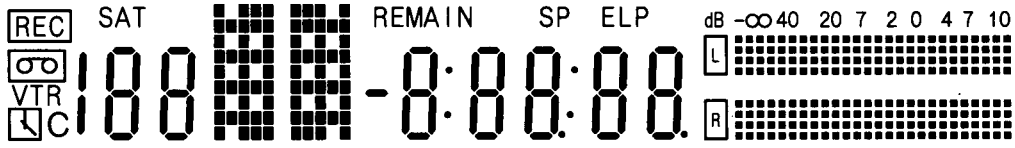

# SEGMENT CONTROL SIGNAL

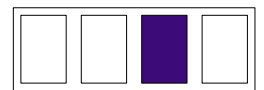
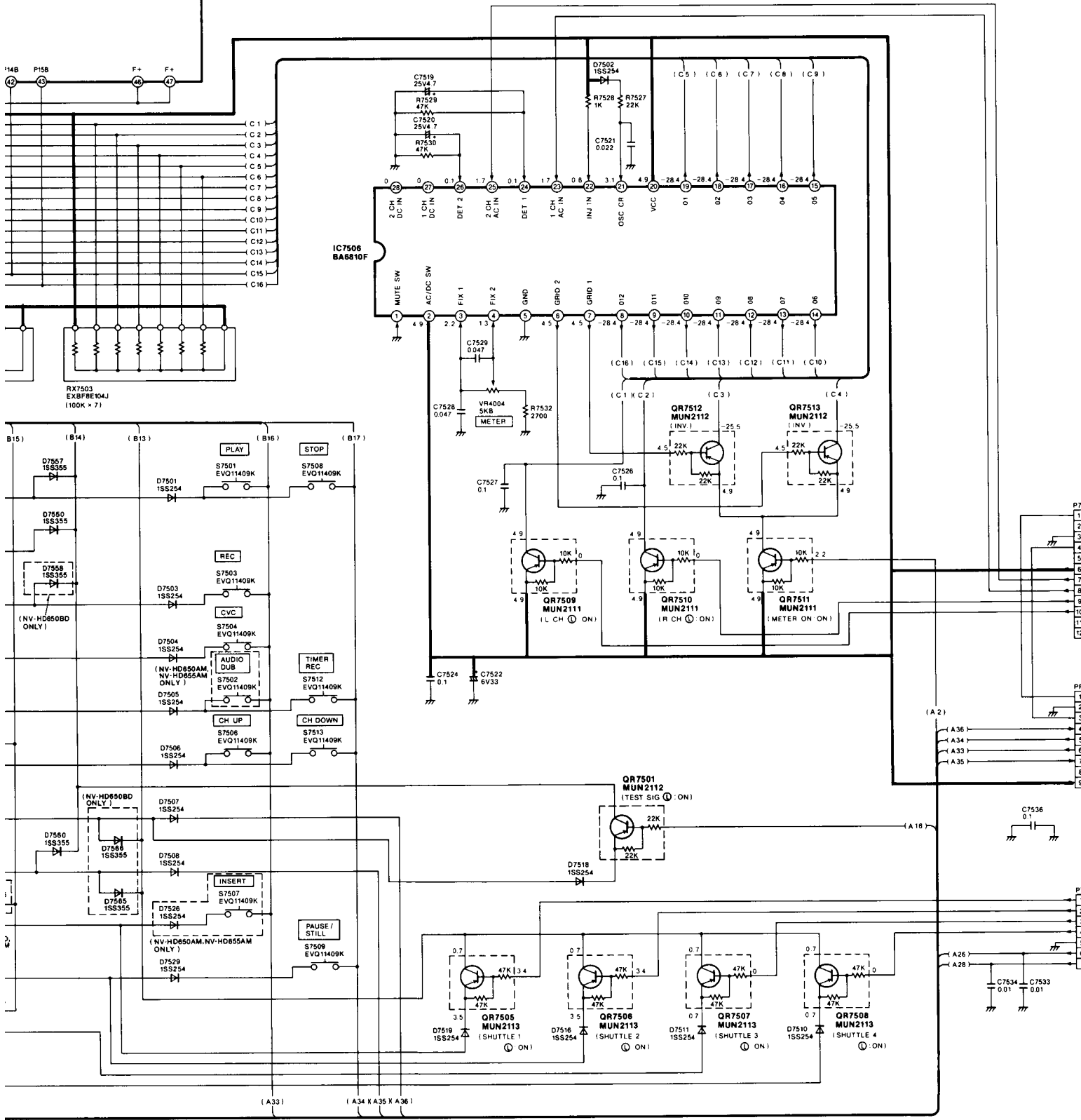



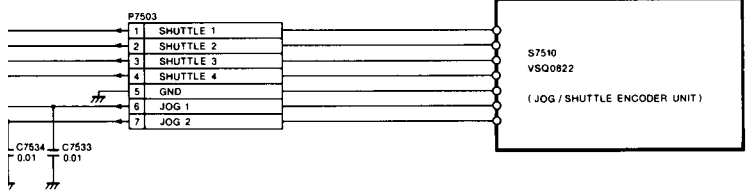
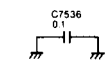
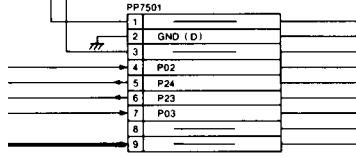
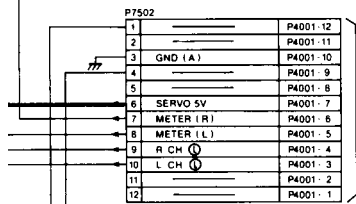
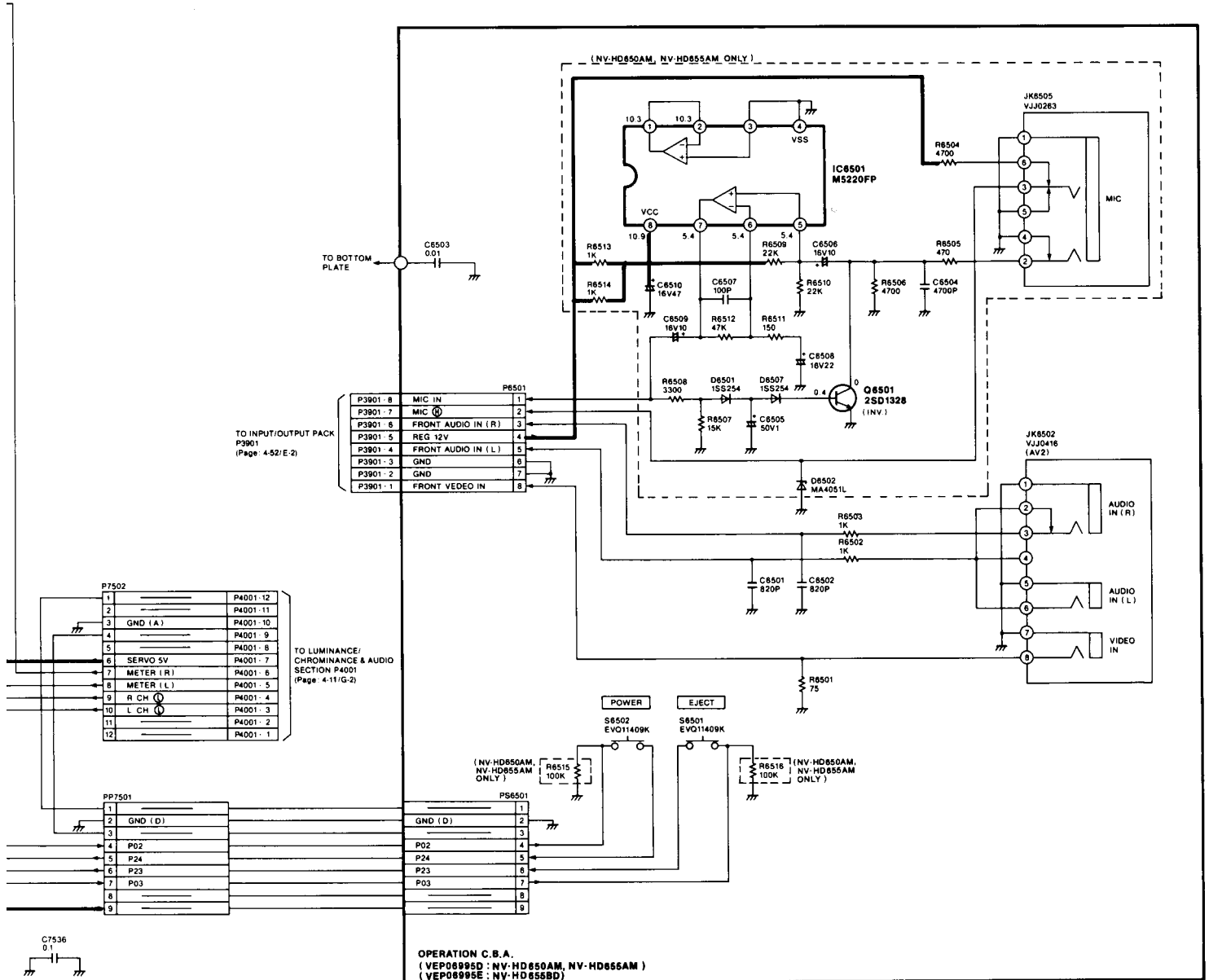

OPERATION C.B.A.  
(VEP08995D: NV-HD850AM, NV-HD866AM)  
(VEP08995E: NV-HD855BD)

NOTE: THE MEASUREMENT MODE OF THE DC VOLTAGE ON THIS DIAGRAM IS STOP MODE.

NOTE: DO NOT USE ANY PART NUMBER SHOWN ON THIS SCHEMATIC DIAGRAM FOR ORDERING. WHEN YOU ORDER A PART, PLEASE REFER TO PARTS LIST.

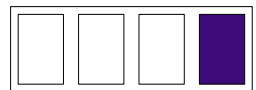

# 4-27. TV DEMODURATOR PACK SCHEMATIC DIAGRAM (NV-HD650BD)

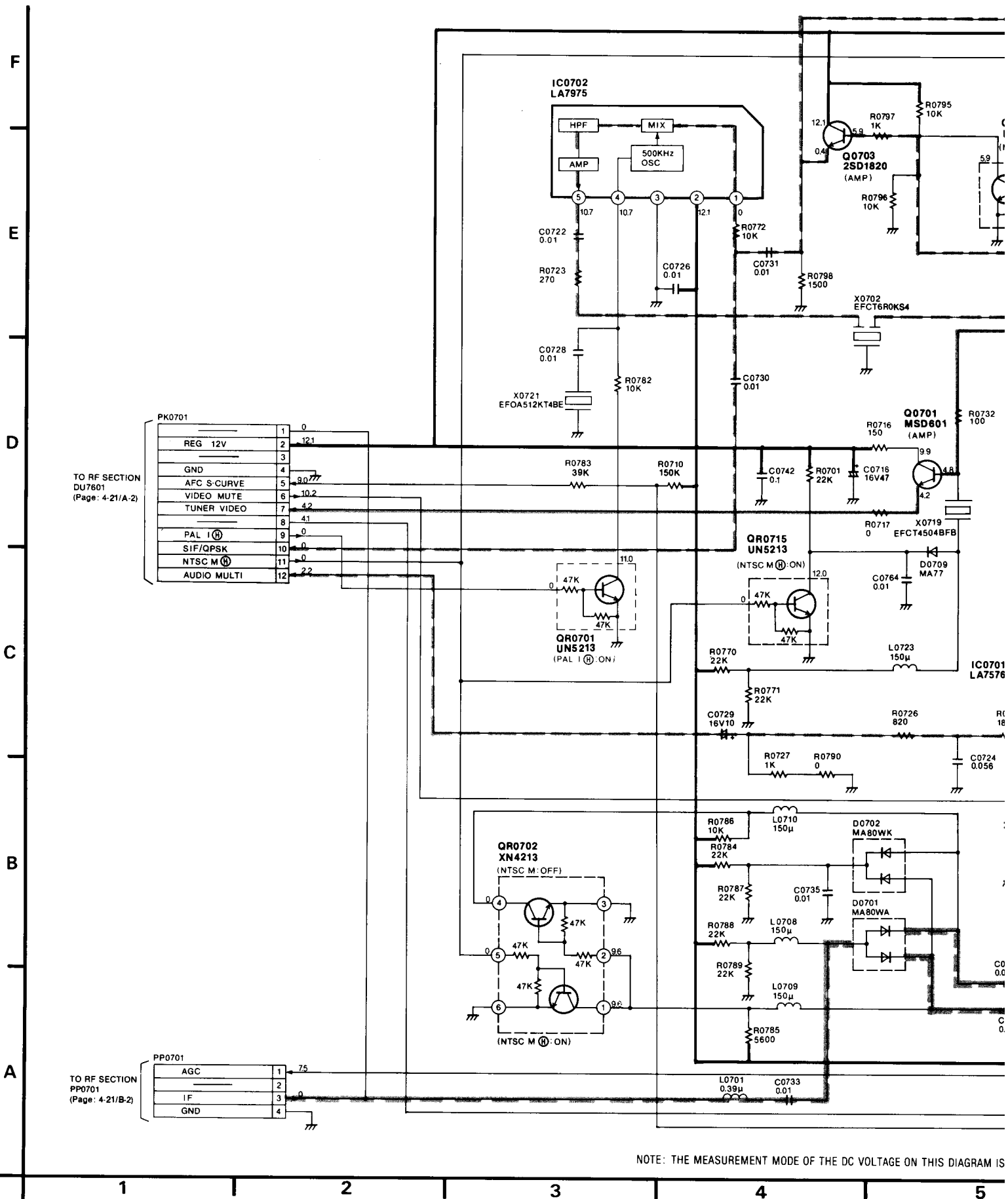

NOTE: THE MEASUREMENT MODE OF THE DC VOLTAGE ON THIS DIAGRAM IS

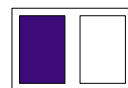

650BD)

VIDEO SIGNAL PATH

AUDIO SIGNAL PATH

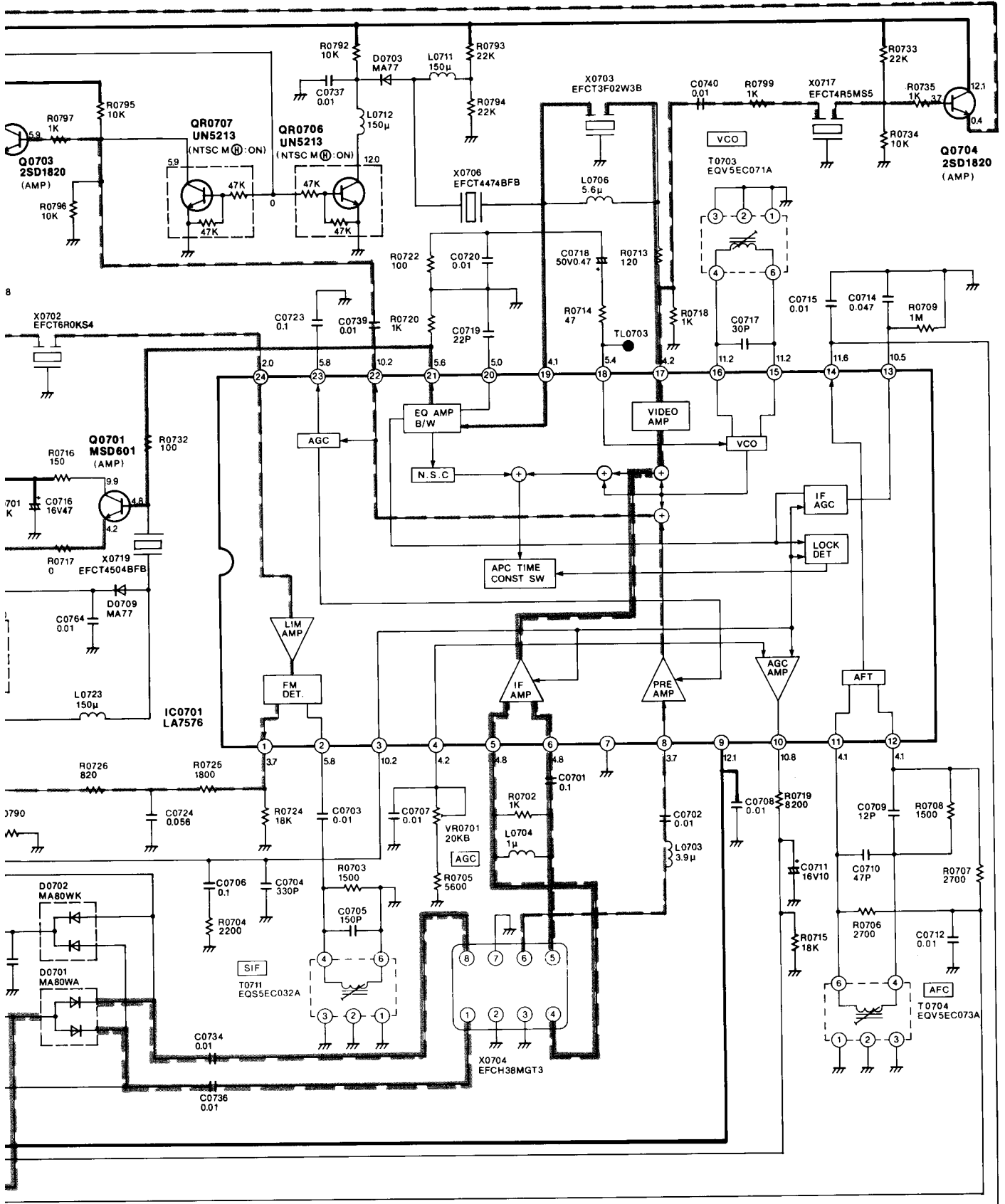

THE DC VOLTAGE ON THIS DIAGRAM IS STOP MODE.

NOTE: DO NOT USE ANY PART NUMBER SHOWN ON THIS SCHEMATIC DIAGRAM FOR ORDERING. WHEN YOU ORDER A PART, PLEASE REFER TO PARTS LIST.

5

6

7

8

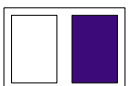

# 4-29. TV DEMODULATOR PACK SCHEMATIC DIAGRAM (NV-HD650AM/EE, NV-HD855AM)

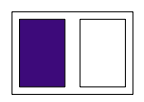
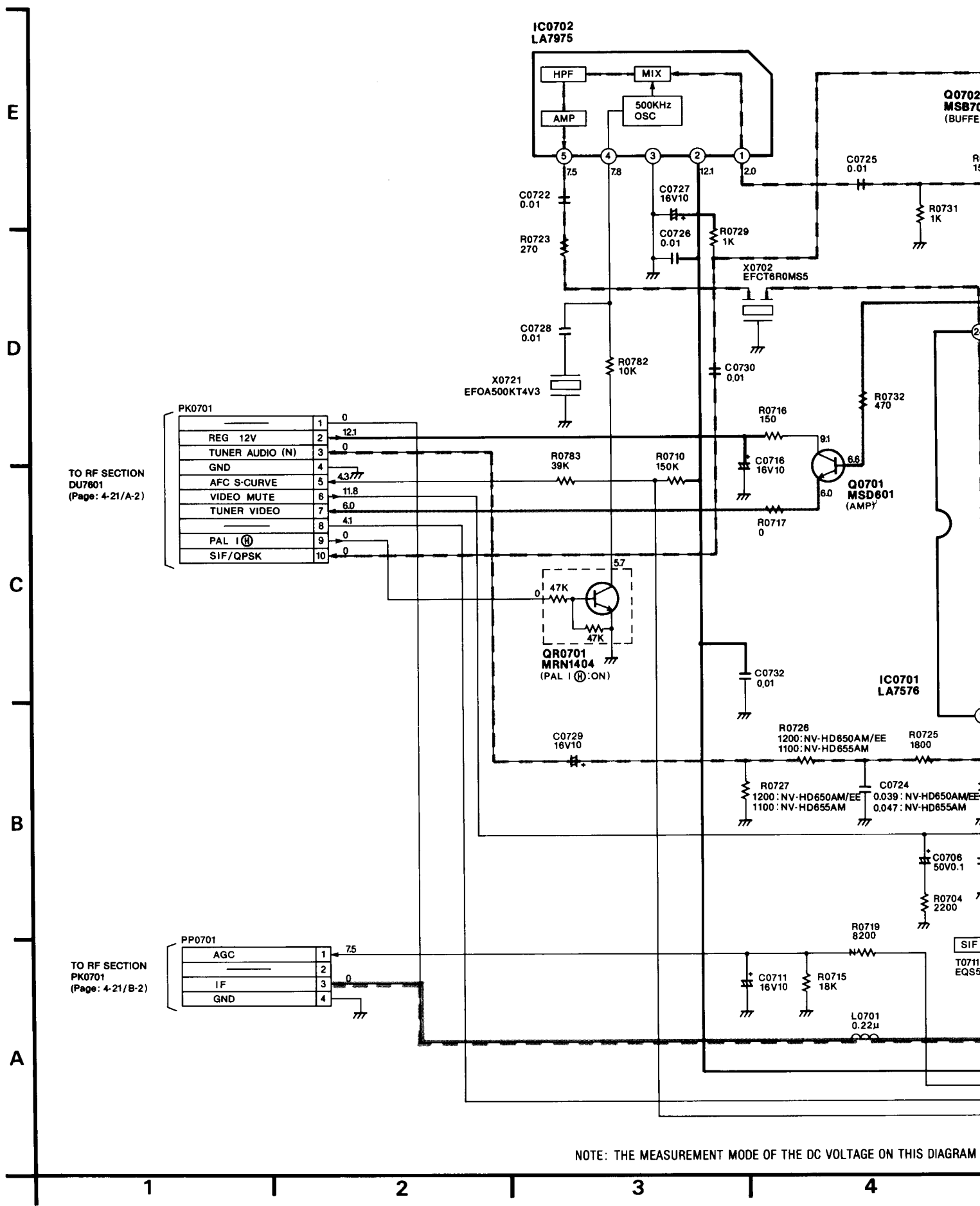

**V/EE, NV-HD655AM)**

———— VIDEO SIGNAL PATH  
 - - - - AUDIO MAIN SIGNAL PATH

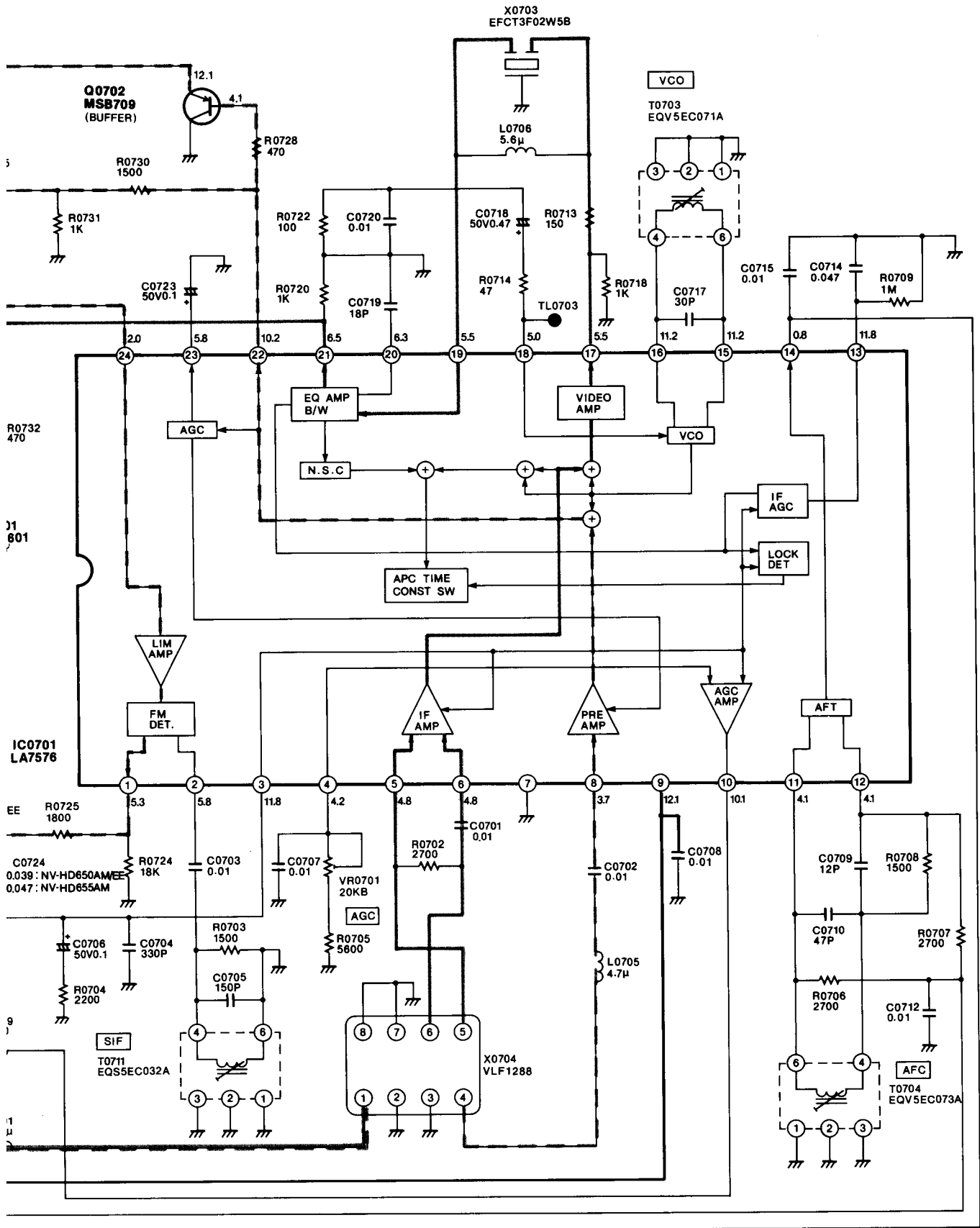

ON THIS DIAGRAM IS STOP MODE.

NOTE: DO NOT USE ANY PART NUMBER SHOWN ON THIS SCHEMATIC DIAGRAM FOR ORDERING. WHEN YOU ORDER A PART, PLEASE REFER TO PARTS LIST.



# 4-31. NICAM DECODER PACK SCHEMATIC DIAGRAM (N)

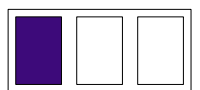
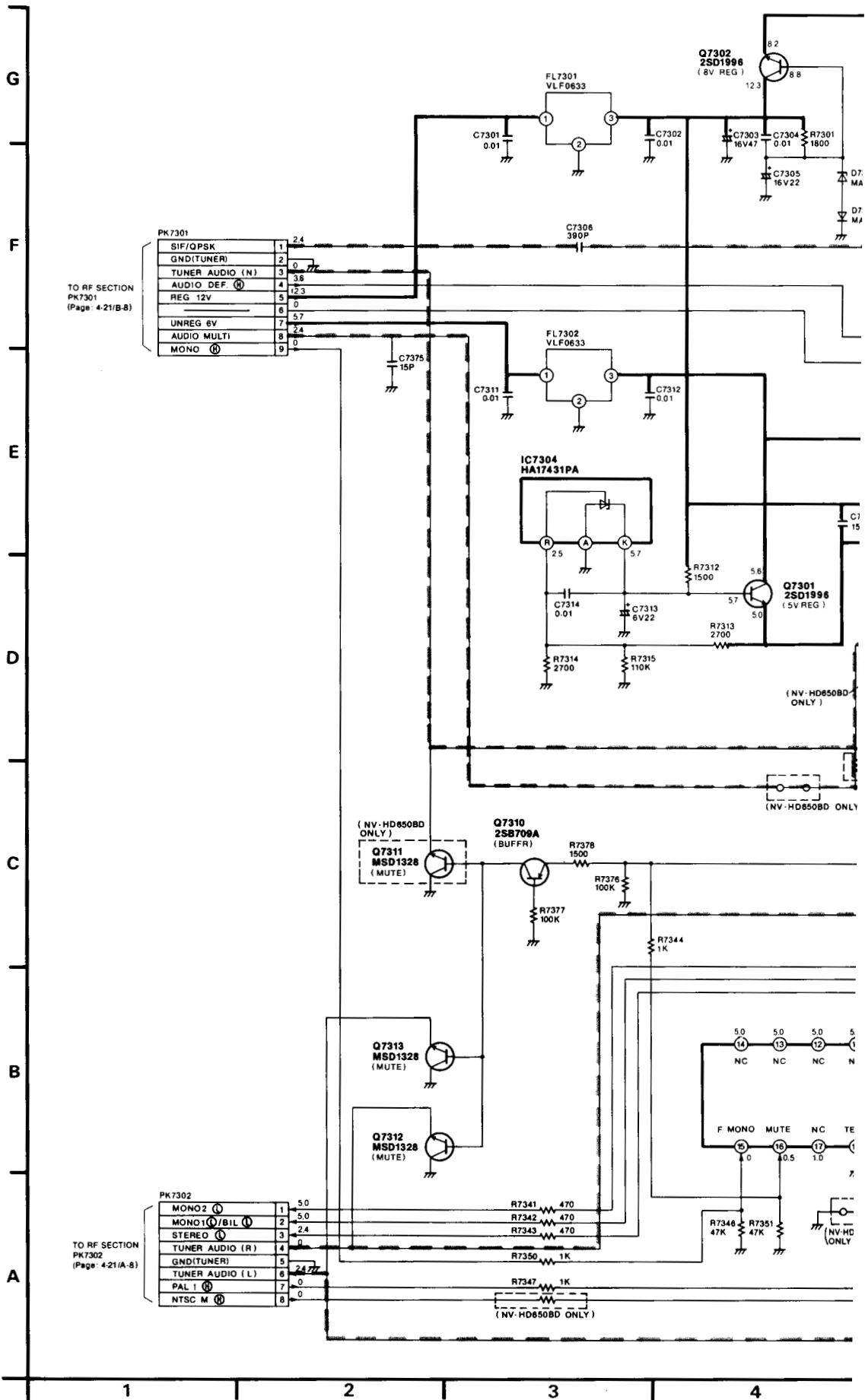

# GRAM (NV-HD650BD, NV-HD655AM)

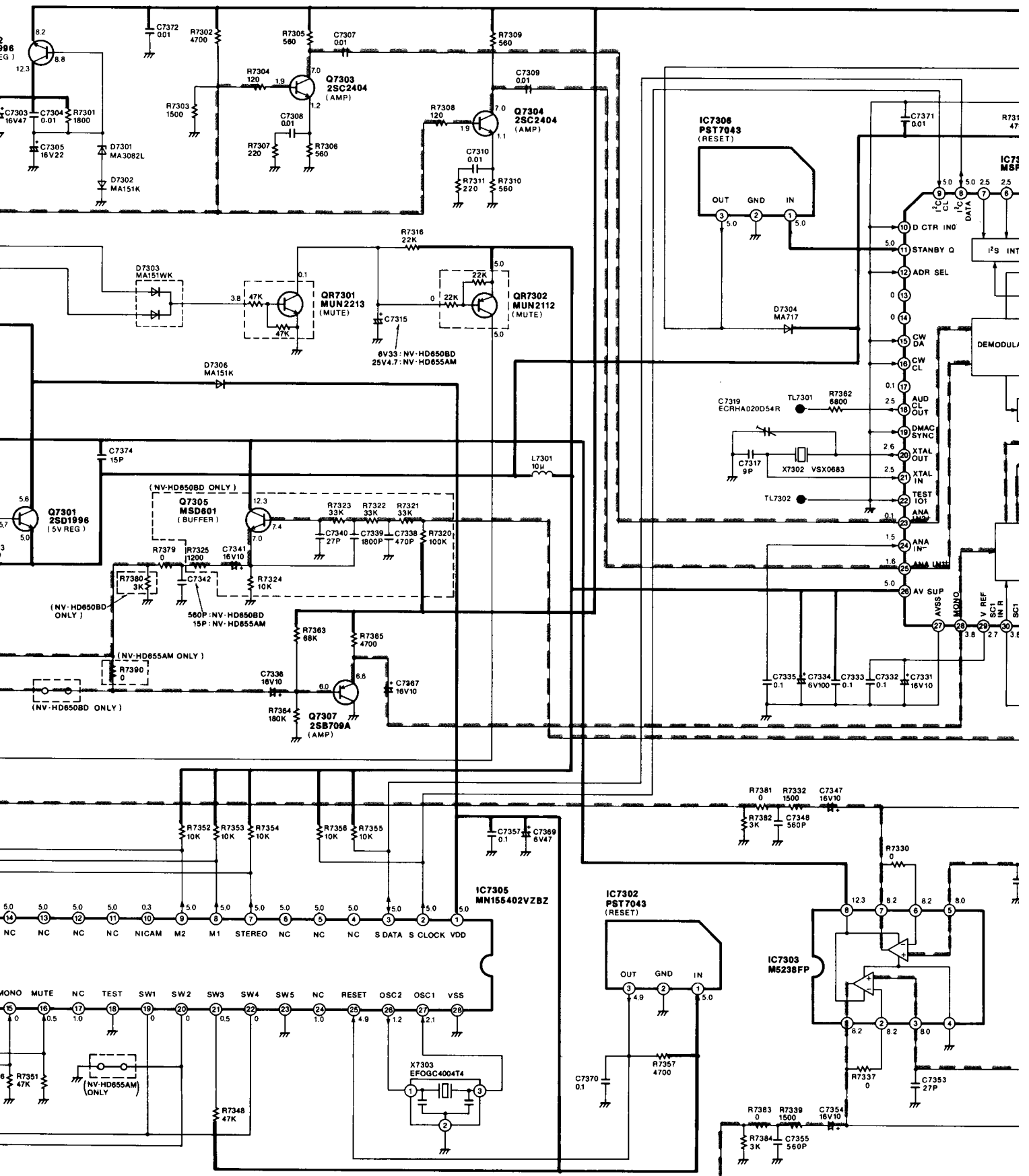

NOTE: THE MEASUREMENT MODE OF THE DC VOLTAGE ON

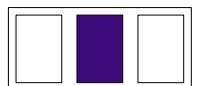

## AUDIO SIGNAL PATH

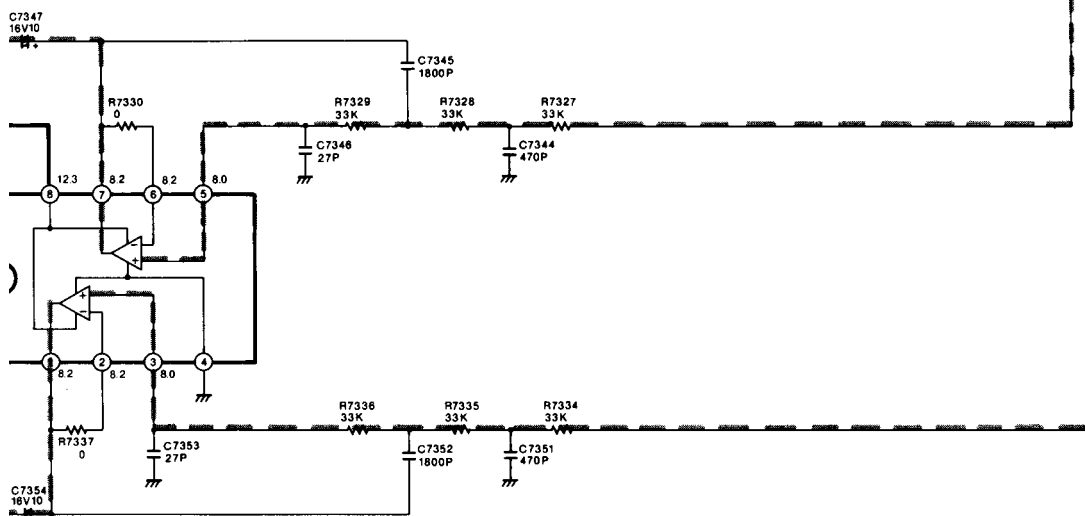
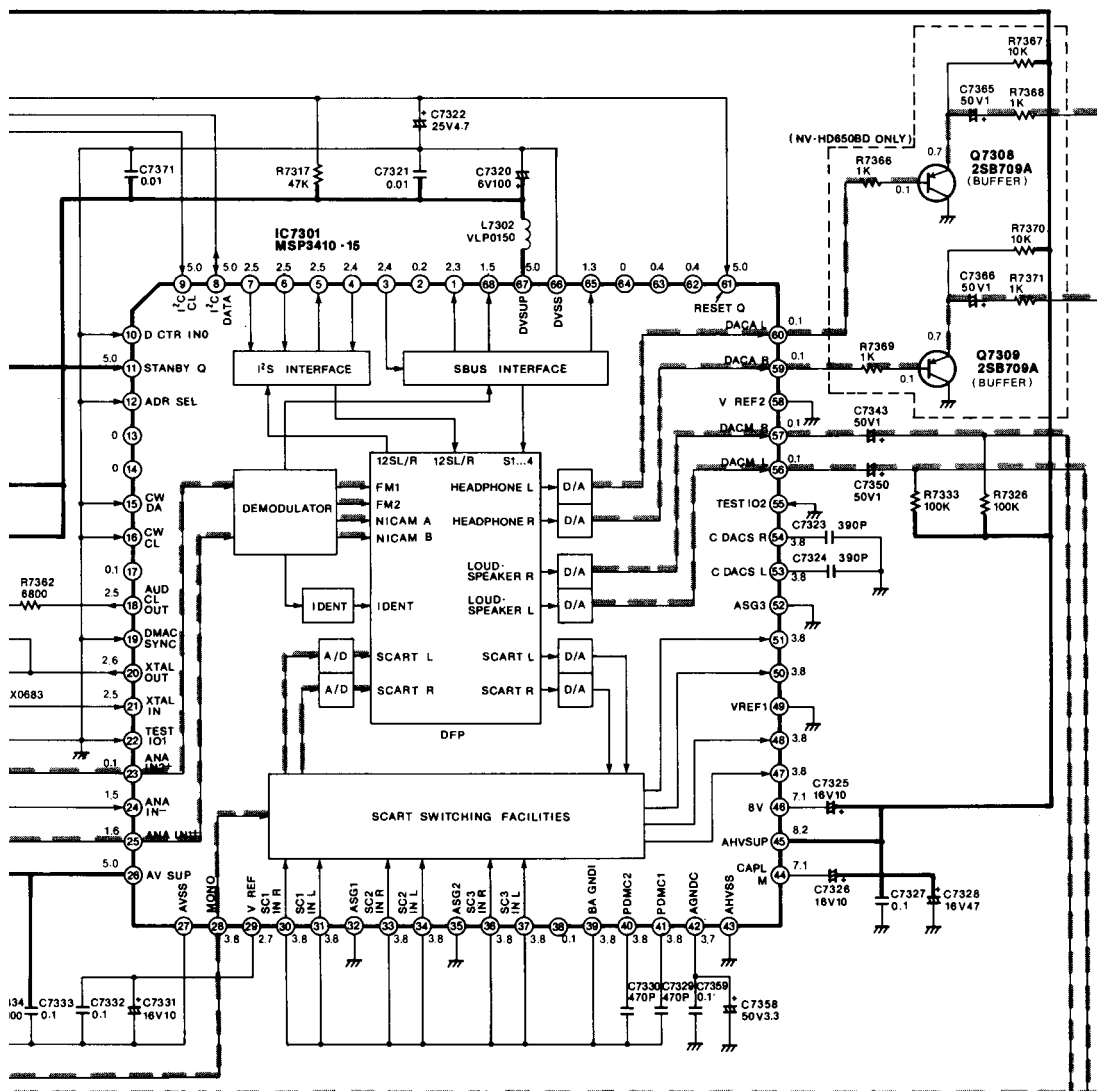

REMENT MODE OF THE DC VOLTAGE ON THIS DIAGRAM IS STOP MODE.

NOTE: DO NOT USE ANY PART NUMBER SHOWN ON THIS SCHEMATIC DIAGRAM FOR ORDERING. WHEN YOU ORDER A PART, PLEASE REFER TO PARTS LIST.

| 9 | 10 | 11 | 12 |

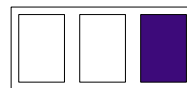

# 4-33. DECODER PACK SCHEMATIC DIAGRAM (NV-HD650AM/EE)

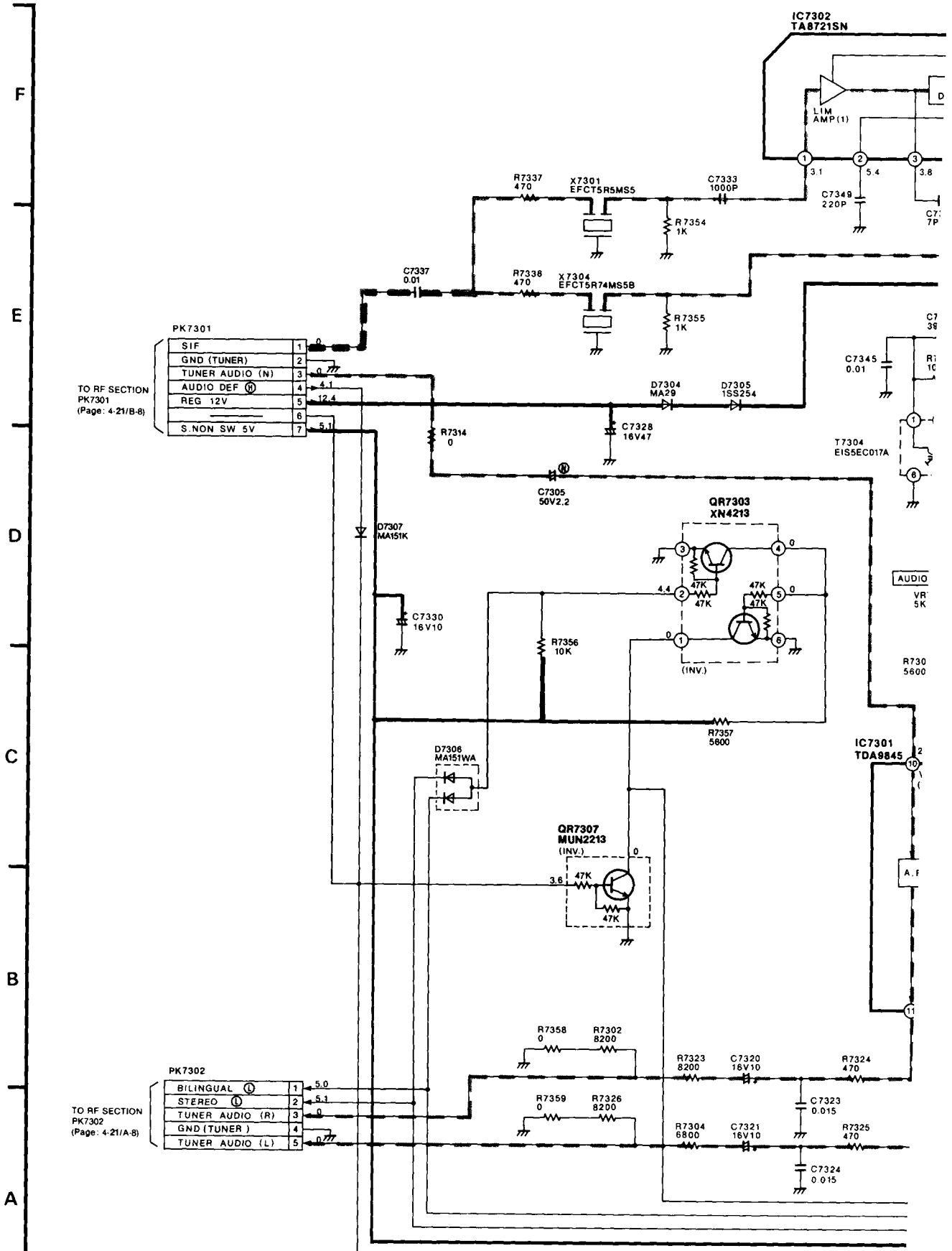

TO RF SECTION  
PK7301  
(Page: 4-21/B-8)

TO RF SECTION  
PK7302  
(Page: 4-21/A-8)

NOTE: DO NOT USE ANY PART NUMBER SHOWN ON THIS SCHEMATIC DIAGRAM FOR ORDERING. WHEN YOU ORDER A PART, PLEASE REFER TO PARTS LIST.

NOTE: THE MEASUREMENT MODE OF THE DC VOLTA

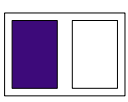

(NV-HD650AM/EE)

--- AUDIO MAIN SIGNAL PATH  
 --- AUDIO SUB SIGNAL PATH

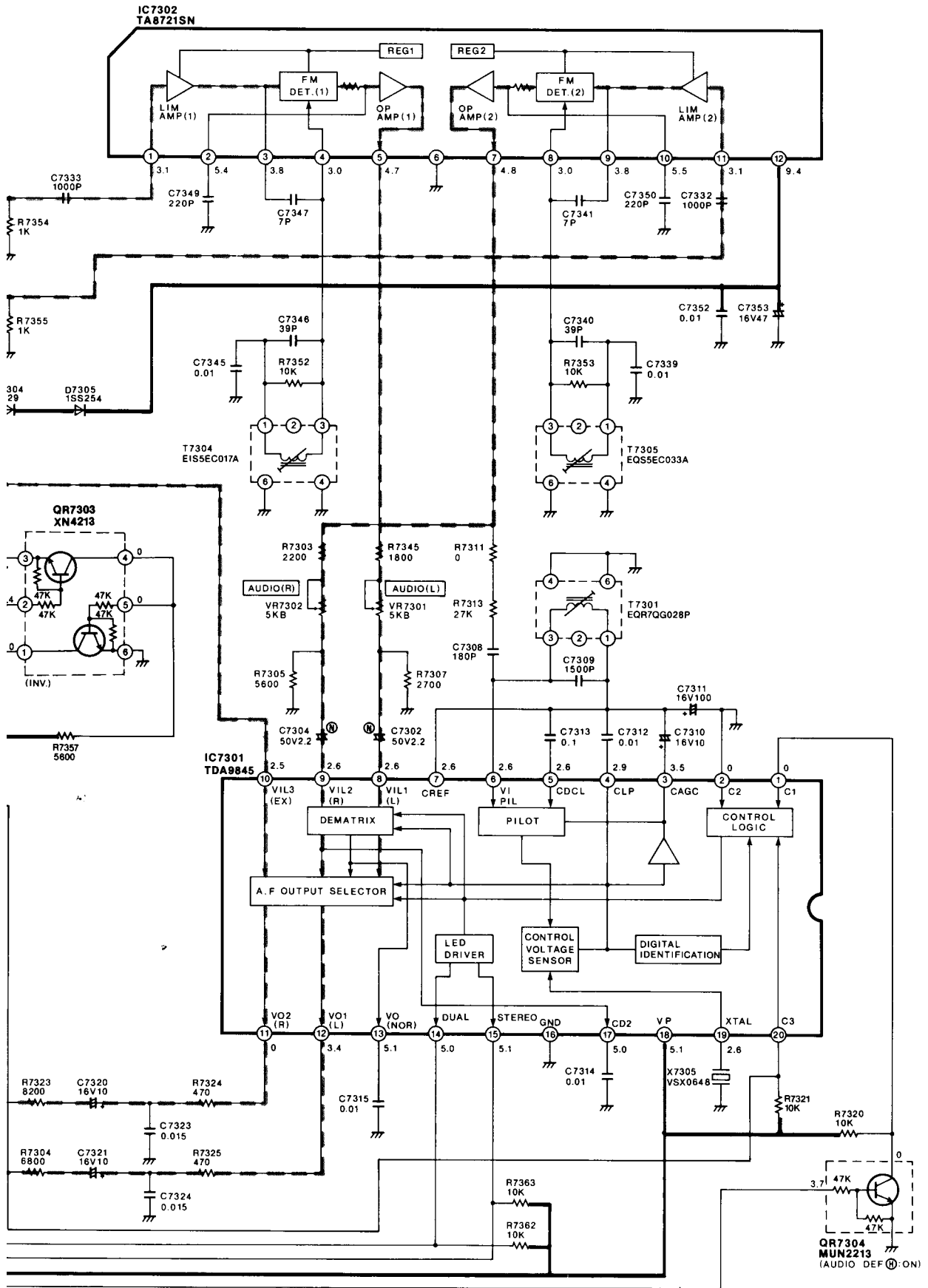

E: THE MEASUREMENT MODE OF THE DC VOLTAGE ON THIS DIAGRAM IS STOP MODE.

