

## TO-220 Plastic Package

## CSC3968

**CSC3968 NPN PLASTIC POWER TRANSISTOR**  
*High Voltage Switching Applications*

## PIN CONFIGURATION

1. BASE
2. COLLECTOR
3. EMITTER
4. COLLECTOR

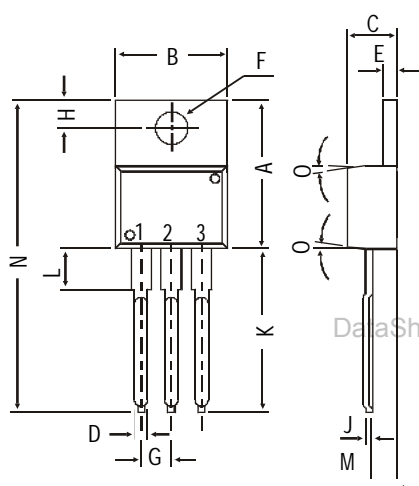
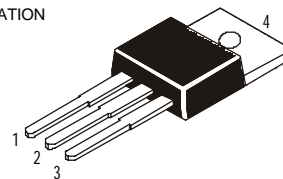

DIM	MIN.	MAX.
A	14.42	16.51
B	9.63	10.67
C	3.56	4.83
D		0.90
E	1.15	1.40
F	3.75	3.88
G	2.29	2.79
H	2.54	3.43
J		0.56
K	12.70	14.73
L	2.80	4.07
M	2.03	2.92
N		31.24
O		DEG 7

All dimensions in mm.

**ABSOLUTE MAXIMUM RATINGS**

Collector-base voltage (open emitter)

 $V_{CB0}$  max. 400 V

Collector-emitter voltage (open base)

 $V_{CEO}$  max. 400 V

Collector current (D.C.)

 $I_C$  max. 2.0 ATotal power dissipation up to  $T_C = 25^\circ\text{C}$  $P_{tot}$  max. 20 W

Junction temperature

 $T_j$  max. 150 °C

Collector-emitter saturation voltage

 $I_C = 1\text{A}; I_B = 0.2\text{A}$  $V_{CEsat}$  max. 1.0 V

D.C. current gain

 $I_C = 0.1\text{A}; V_{CE} = 5\text{V}$  $h_{FE}$  min. 16

max. 50

**RATINGS** (at  $T_A=25^\circ\text{C}$  unless otherwise specified)

## Limiting values

Collector-base voltage (open emitter)

 $V_{CB0}$  max. 400 V

Collector-emitter voltage (open base)

 $V_{CEO}$  max. 400 V

Emitter-base voltage (open collector)

 $V_{EBO}$  max. 7.0 V

Collector current (DC)

 $I_C$  max. 2.0 A

Collector current (Pulse) (1)

 $I_C$  max. 4.0 A

## CSC3968

Total power dissipation up to $T_C = 25^\circ\text{C}$	$P_{tot}$	max.	20 W
Total power dissipation up to $T_A = 25^\circ\text{C}$	$P_{tot}$	max.	1.5 W
Junction temperature	$T_j$	max.	150 °C
Storage temperature	$T_{stg}$		-65 to +150 °C

**CHARACTERISTICS**

$T_{amb} = 25^\circ\text{C}$  unless otherwise specified

Collector cutoff current

$$I_E = 0; V_{CB} = 400\text{V}$$

$$I_{CBO} \quad \text{max.} \quad 10 \mu\text{A}$$

Emitter cut-off current

$$I_C = 0; V_{EB} = 7\text{V}$$

$$I_{EBO} \quad \text{max.} \quad 10 \mu\text{A}$$

Breakdown voltages

$$I_C = 1 \text{ mA}; I_B = 0$$

$$V_{CEO} \quad \text{min.} \quad 400 \text{ V}$$

$$I_C = 50 \mu\text{A}; I_E = 0$$

$$V_{CBO} \quad \text{min.} \quad 400 \text{ V}$$

$$I_E = 50 \mu\text{A}; I_C = 0$$

$$V_{EBO} \quad \text{min.} \quad 7.0 \text{ V}$$

Saturation voltages

$$I_C = 1 \text{ A}; I_B = 0.2 \text{ A}$$

$$V_{CEsat}^* \quad \text{max.} \quad 1.0 \text{ V}$$

$$V_{BEsat}^* \quad \text{max.} \quad 1.5 \text{ V}$$

D.C. current gain

$$I_C = 0.1\text{A}; V_{CE} = 5\text{V}^{**}$$

$$h_{FE} \quad \text{min.} \quad 16$$

$$\text{max.} \quad 50$$

Output capacitance at  $f = 1 \text{ MHz}$

$$I_E = 0; V_{CB} = 10\text{V}$$

$$C_o \quad \text{typ.} \quad 30 \text{ pF}$$

Transition frequency

$$I_C = 0.5\text{A}; V_{CE} = 10\text{V}; f = 5 \text{ MHz}$$

$$f_T^* \quad \text{typ.} \quad 10 \text{ MHz}$$

**Switching time**

$$I_C = 0.8\text{A}; R_L = 250\Omega$$

$$I_{B1} = -I_{B2} = 0.08\text{A}$$

$$V_{CC} = 200\text{V}$$

Turn on time

$$t_{on} \quad \text{max.} \quad 1.0 \mu\text{s}$$

Storage time

$$t_s \quad \text{max.} \quad 2.5 \mu\text{s}$$

Fall time

$$t_f \quad \text{max.} \quad 1.0 \mu\text{s}$$

(1) Single Pulse  $P_w = 10 \text{ ms}$

\* Pulse test

\*\*  $h_{FE}$  classification: A: 16-34 B: 25-50

## Customer Notes

et4U.com

DataSheet4U.com

### Disclaimer

The product information and the selection guides facilitate selection of the CDIL's Discrete Semiconductor Device(s) best suited for application in your product(s) as per your requirement. It is recommended that you completely review our Data Sheet(s) so as to confirm that the Device(s) meet functionality parameters for your application. The information furnished on the CDIL Web Site/ CD are believed to be accurate and reliable. CDIL however, does not assume responsibility for inaccuracies or incomplete information. Furthermore, CDIL does not assume liability whatsoever, arising out of the application or use of any CDIL product; neither does it convey any license under its patent rights nor rights of others. These products are not designed for use in life saving/support appliances or systems. CDIL customers selling these products (either as individual Discrete Semiconductor Devices or incorporated in their end products), in any life saving/support appliances or systems or applications do so at their own risk and CDIL will not be responsible for any damages resulting from such sale(s).

CDIL strives for continuous improvement and reserves the right to change the specifications of its products without prior notice.



CDIL is a registered Trademark of  
**Continental Device India Limited**

C-120 Naraina Industrial Area, New Delhi 110 028, India.  
Telephone + 91-11-2579 6150, 5141 1112 Fax + 91-11-2579 5290, 5141 1119  
email@cdil.com www.cdilsemi.com

DataSheet4U.com

www.DataSheet4U.com