

# LCD Module Technical Specification

Type No. **F-51900NCU-FW-AC**

*M. Akatsuka*

Approved by (Quality Assurance Division)

液晶之友 电话: 020-33819057  
Http://www.lcdfriends.com

*N. Wada*

Checked by (ACI Engineering Division)

*M. Matsuura*

Prepared by (ACI Engineering Division)

## Table of Contents

1. General Specifications .....	2
2. Electrical Specifications .....	3
3. Optical Specifications .....	10
4. I/O Terminal .....	12
5. Test .....	14
6. Appearance Standards .....	15
7. Code System of Production Lot .....	18
8. Type Number .....	18
9. Applying Precautions .....	18
10. Precautions Relating Product Handling .....	19
11. Warranty .....	20

## Revision History

Rev.	Date	Page	Comment

## 1.General Specifications

Operating Temp.	:	min. 0°C ~max. 50°C
Storage Temp.	:	min. -20°C ~max. 70°C
Dot Pixels	:	320 × 3 [R.G.B] (W) × 240 (H) dots
Dot Size	:	0.1 (W) × 0.34 (H) mm
Dot Pitch	:	0.12 (W) × 0.36 (H) mm
Viewing Area	:	120.0 (W) × 90.0 (H) mm
Outline Dimensions	:	168.0* (W) × 111.0 (H) × 9.4 max. (D) mm * Without CFL Cable
Weight	:	276g max.
Viewing Angle	:	12:00
Data Transfer	:	8-bit parallel data transfer
Backlight	:	Cold Cathode Fluorescent Lamp (CFL) × 1
Drawings	:	Dimensional Outline UE-312546

## 2. Electrical Specifications

### 2.1. Absolute Maximum Ratings

V<sub>SS</sub>=0V

Parameter	Symbol	Conditions	Min.	Max.	Units
Supply Voltage (Logic)	V <sub>CC1</sub> -V <sub>SS</sub>	-	-0.3	6.5	V
Supply Voltage (LCD Drive)	V <sub>vadj</sub>	-	-0.3	2.5	V

### 2.2. DC Characteristics

T<sub>a</sub>=25°C, V<sub>SS</sub>=0V

Parameter	Symbol	Conditions	Min.	Typ.	Max.	Units
Supply Voltage (Logic)	V <sub>CC1</sub> -V <sub>SS</sub>	-	4.5	5.0	5.5	V
			2.5	3.0	3.5	
Supply Voltage (LCD Drive)	V <sub>vadj</sub>	-	1.5	2.0	2.5	V
High Level Input Voltage	V <sub>IH</sub>	V <sub>CC1</sub> =5.0V±10%	0.8V <sub>CC1</sub>	-	V <sub>CC1</sub>	V
Low Level Input Voltage	V <sub>IL</sub>	V <sub>CC1</sub> =5.0V±10%	0	-	0.2V <sub>CC1</sub>	V
Supply Current	I <sub>CC1</sub>	V <sub>CC1</sub> -V <sub>SS</sub> =3.0V V <sub>vadj</sub> =2.0 Checker Board pattern	-	100	120	mA
		V <sub>CC1</sub> -V <sub>SS</sub> =5.0V V <sub>vadj</sub> =2.0 Checker Board pattern		55	82.5	mA

### 2.3.Characteristics of Touch Screen

Parameter	Conditions	Min.	Typ.	Max.	Units
Applied Rating Voltage	-	-	-	7.0	V
Resistance of Terminal Electrodes	X Electrode	300	-	900	Ω
	Y Electrode	200	-	650	
Linearity	-	-	-	1.5	%
Insulation Resistance	V <sub>DC</sub> =25V	10	-	-	MΩ
Surface Hardness	According to JIS-K5400	3	-	-	H
Chattering	At connector Pin	-	-	10	mS

Test condition : Touch screen is placed horizontally in a vessel and no power is supplied to T/P.

Normal state is temperature : 2.5±10°C, relative humidity : 60±25°C

## 2.4.AC Characteristics

$V_{CC}=3.0/5.0V\pm 10\%$

Parameter	Symbol	Min.	Max.	Units
Clock Pulse Cycle Time	$t_{WCK}$	66/40	-	ns
Clock Pulse High Level Width	$t_{WCKH}$	23/12	-	ns
Clock Pulse Low Level Width	$t_{WCKL}$	23/14	-	ns
Latch Pulse High Level Width	$t_{WLPH}$	30/15	-	ns
CP → LP Rise Time	$t_{LD}$	10/5	-	ns
CP → LP Fall Time	$t_{SL}$	30/25	-	ns
LP → CP Rise Time	$t_{LS}$	30/25	-	ns
LP → CP Fall Time	$t_{LH}$	30/25	-	ns
Clock Pulse Rise/Fall Time	$t_r, t_f$	-	50	ns
Data Setup Time	$t_{DS}$	10/5	-	ns
Data Hold Time	$t_{DH}$	25/15	-	ns
DISPOFF Low Level Width	$t_{WDL}$	1.2	-	$\mu s$
DISPOFF Cancellation Time	$t_{SD}$	100	-	ns
FLM Setup Time	$t_{SU}$	30	-	ns
FLM Hold Time	$t_H$	50	-	ns

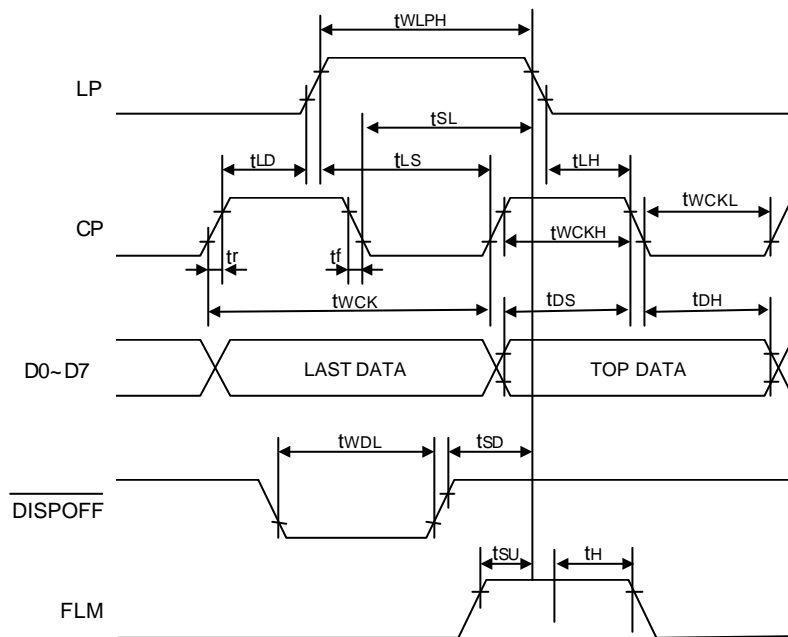

## 2.5. Timing Chart

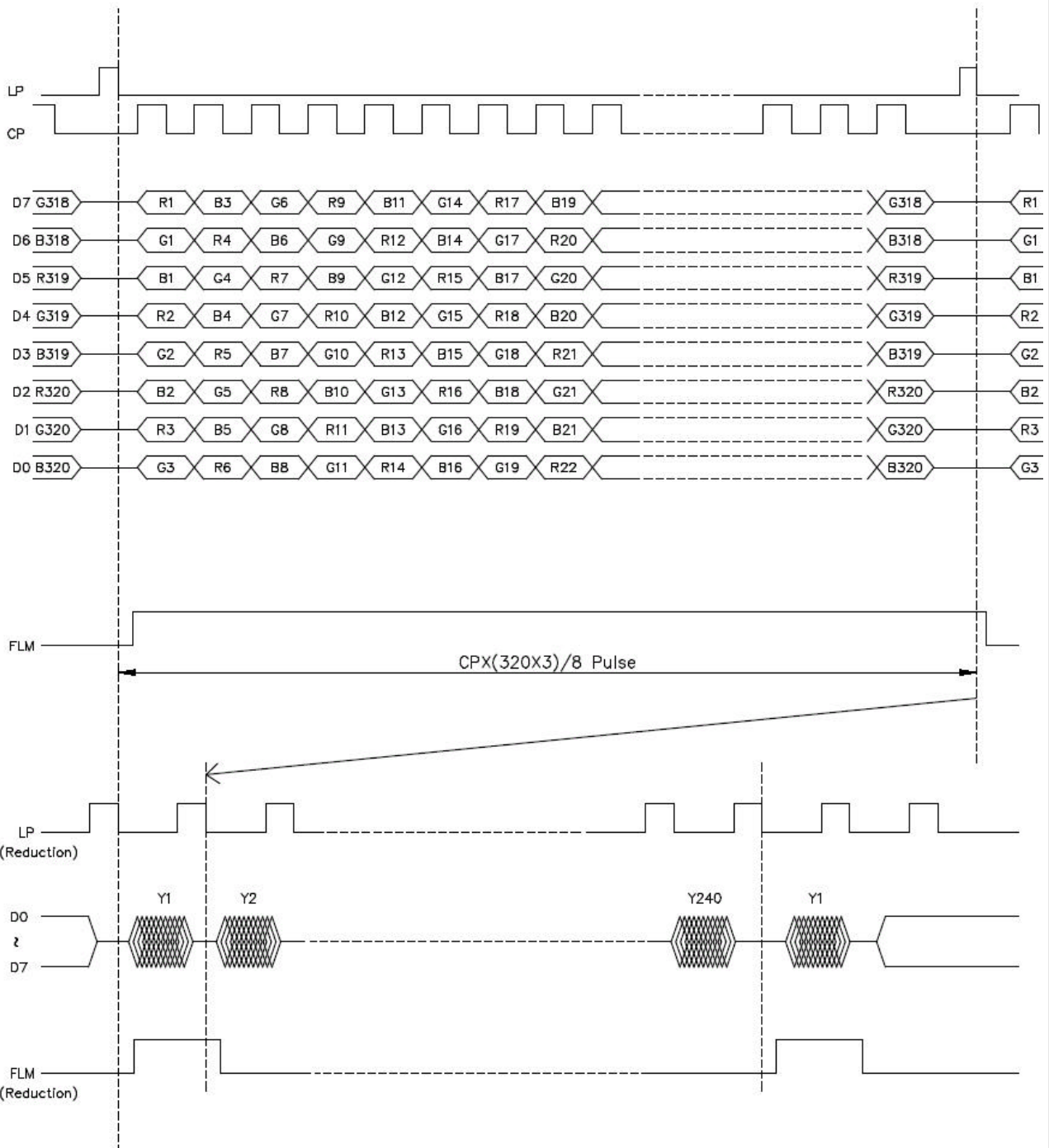

## 2.6. Comparison of Display and Data

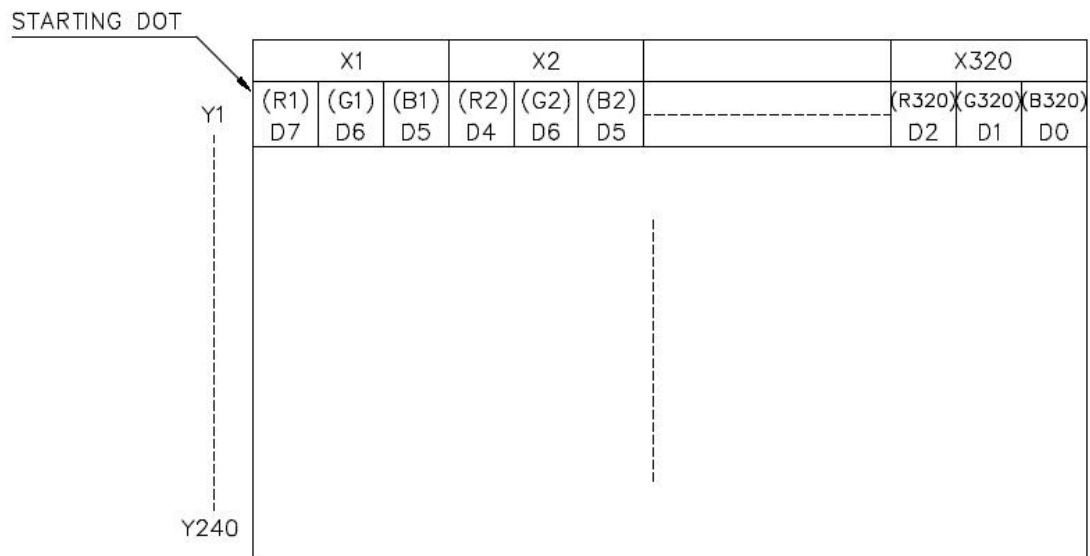

D0~D7 are 8 bits transmitted data, where D0 is LSB and D7 is MSB.

## 2.7. Power Supply ON/OFF Sequence

### 2.7.1. ON Sequence

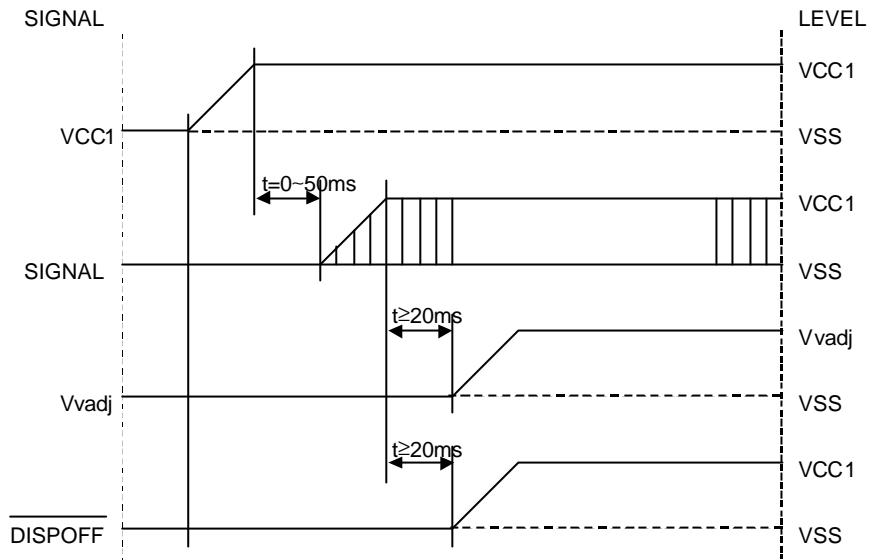

### 2.7.2. OFF Sequence

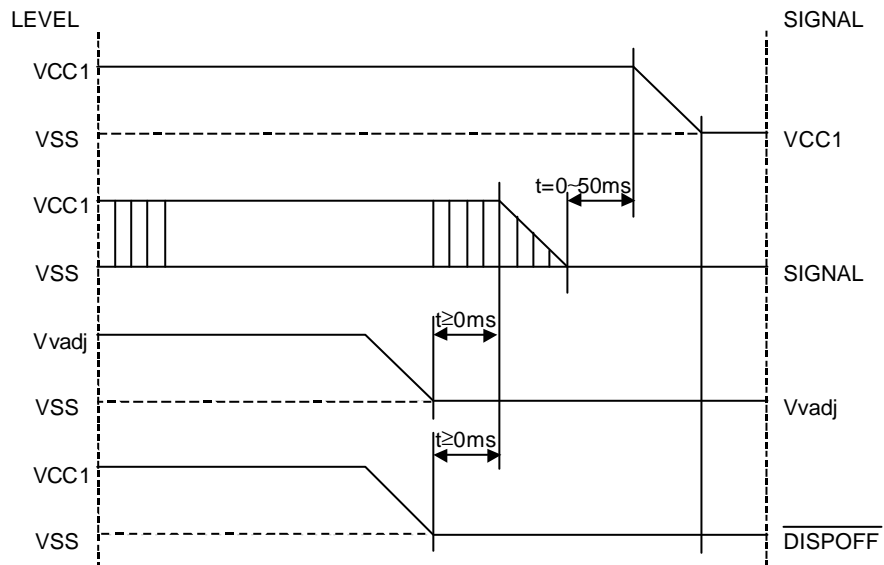

Please maintain the above sequence when turning on and off the power supply of the module.

If DISPOFF is supplied to the module while internal alternate signal for LCD driving (M) is unstable, DC component will be supplied to the LCD panel. This may cause damage the LCD module.



## 2.8. Power Supply ON/OFF Sequence

Ta=25°C

Parameter	Symbol	Conditions	Min.	Typ.	Max.	Units	Notes
Lamp Voltage	V <sub>L</sub>	-	-	297	-	V <sub>rms</sub>	1
Lamp Current	I <sub>L</sub>	-	4	5	6	mA <sub>rms</sub>	2
Starting Voltage	V <sub>s</sub>	-	-	-	570	V <sub>rms</sub>	3
Surface Luminance	L	I <sub>L</sub> =5mA	80	100	-	cd/m <sup>2</sup>	4
Average Life	T <sub>AL</sub>	I <sub>L</sub> =5mA	20000	-	-	hrs	5

Note 1 :The voltage ( r.m.s. ) to maintain the electric discharge of the lamp. It is measured after lighting for 3 minutes .

Note 2 :The current ( r.m.s. ) to flow through the lamp with the electric discharge. It is measured after lighting for 3 minutes.

Note 3 :The voltage at starting the electric discharge when the voltage is increased gradually from 0V.

Note 4 :Surface Luminance is specified by the average of 9 luminance values measured at each point shown above after 20 minutes power on with the all ON pattern adjusted to maximum contrast and the dimming control of 100%. ( maximum brightness )  
Surface Luminance is Through Touch Screen.

Note 5 : CFL Life is defined as time period that the actual luminance becomes 50% or lower of its initial value.

The Average life time of CFL is defined as the time when half or more of the testing CFLs have become less bright than 50% of the initial brightness at continuous operation.

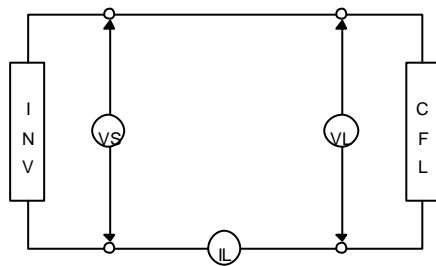

CFL Testina Circuit

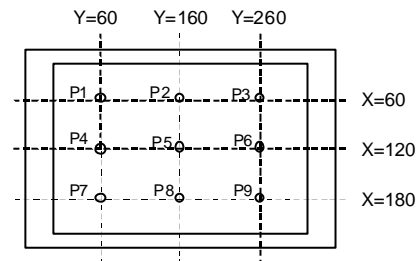

Measurement Points

Recommended Inverter : TBD086N-4

CXA-L10L (DC 12.0V, Produced by TDK)

### 3. Optical Specifications

#### 3.1. Optical Characteristics

Ta=25°C, 1/240 Duty, 1/13 Bias, V<sub>OD</sub>=22.5 V (Note 4), θ= 0°, φ=-°

Parameter	Symbol	Conditions	Min.	Typ.	Max.	Units
Contrast Ratio Note 1	CR	θ= 0°, φ=-°	17	25	-	
Chromaticity(White)	x	-	-	0.30	-	
	y	-	-	0.31	-	
Viewing Angle		Shown in 3.2				
Response Time	Rise Note 2	T <sub>ON</sub>	-	300	450	ms
	Decay Note 3	T <sub>OFF</sub>	-	100	150	ms

Note 1 : Contrast ratio is defined as follows. (CR = L<sub>OFF</sub> / L<sub>ON</sub>)

L<sub>ON</sub> : Luminance of the ON segments

L<sub>OFF</sub> : Luminance of the OFF segments

Note 2 : The time that the luminance level reaches 90% of the saturation level from 0% when ON signal is applied.

Note 3 : The time that the luminance level reaches 10% of the saturation level from 100% when OFF signal is applied.

Note 4 : Definition of Driving Voltage V<sub>OD</sub>

Assuming that the typical driving waveforms shown below are applied to the LCD Panel at 1/A Duty - 1/B Bias (A: Duty Number, B: Bias Number). Driving voltage V<sub>OD</sub> is defined as follows.

$$V_{OD} = (V_{th1} + V_{th2}) / 2$$

V<sub>th1</sub>: The voltage V<sub>O-P</sub> that should provide 90% of the saturation level in the luminance at the segment which the ON signal is applied to.

V<sub>th2</sub>: The voltage V<sub>O-P</sub> that should provide 10% of the saturation level in the luminance at the segment which the OFF signal is applied to.

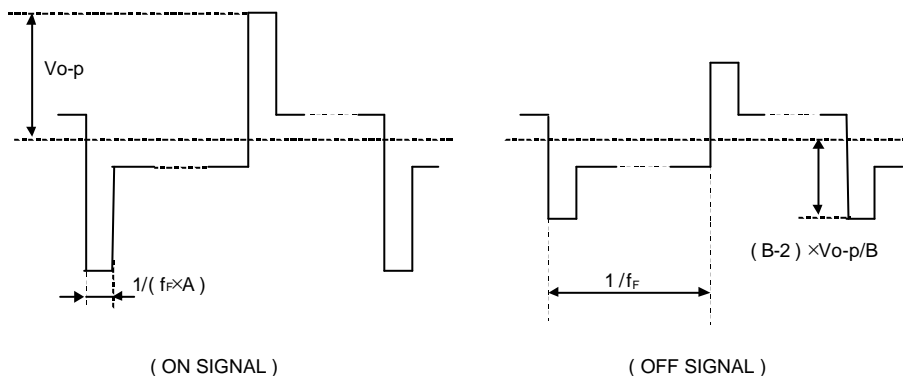

### 3.2. Definition of Viewing Angle and Optimum Viewing Area

\*Driving condition: 1/240 Duty, 1/13Bias,  $V_D V_{OD} = 22.5V$ ,  $f_F = 70Hz$

CR $\geq$ 2

$\phi = L:46^\circ$  R: $42^\circ$

$\theta = F:20^\circ$  R: $37^\circ$

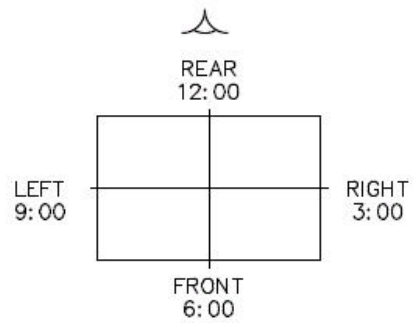
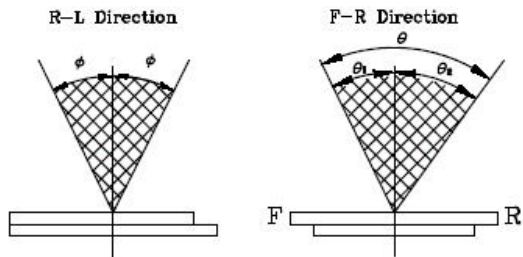

**\*For This Product**  
**The Viewing Direction Is 12 O'clock**  
**So  $\theta_1 < \theta_2$**

### 3.3. System Block Diagram

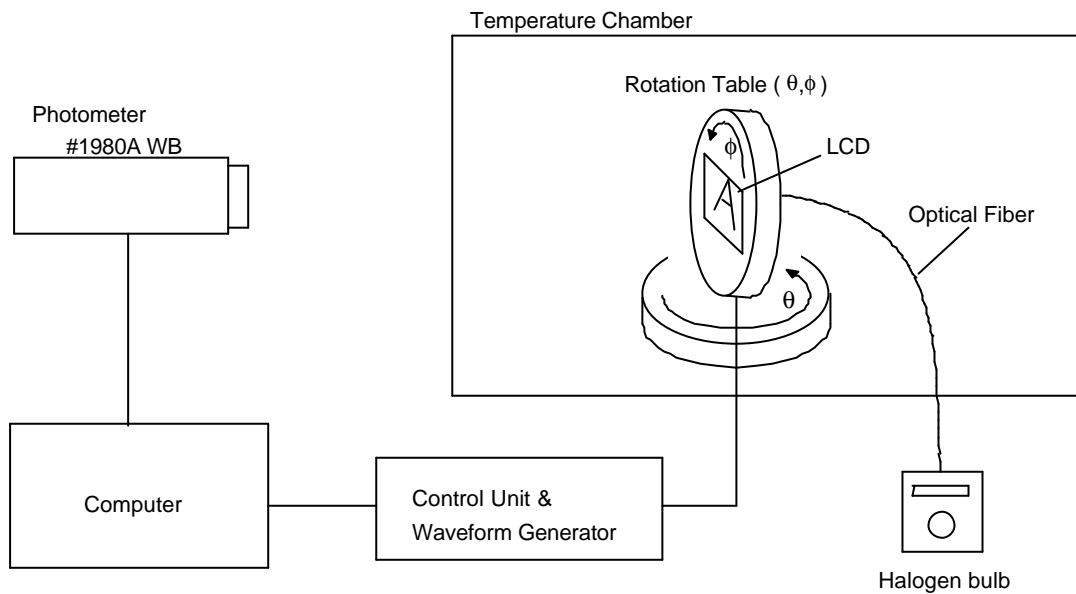

## 4. I/O Terminal

### 4.1. Pin Assignment

#### CN1

No.	Symbol	LEVEL	Function
1 2 3 4 5 6 7 8	D0 D1 D2 D3 D4 D5 D6 D7	H/L	Display Data
9	DISPOFF	H/L	Display Control Signal H : Display on L : Display off
10	FLM	H/L	First Line Marker
11	LP	H→L	Data Latch Signal
12	CP	H→L	Clock Signal for Shifting Data
13	M	H/L	Alternate Signal for LCD Drive
14	V <sub>cc1</sub>	-	Power Supply for LCD Drive
15	V <sub>ss</sub>	-	Power Supply (0V, GND)
16	V <sub>ss</sub>	-	Power Supply (0V, GND)
17	V <sub>cc2</sub>	-	Power Supply for LCD Drive
18	V <sub>VADJ</sub>	-	Voltage Level for LCD Contrast Adjustment

#### CN2

No.	Symbol	LEVEL	Function
1	VCFL	-	Power Supply for CFL (HOT)
2	NC	-	No connection
3	NC	-	No connection
4	VSS	-	Power Supply for CFL (GND)

#### CN3

No.	Symbol	LEVEL	Function
1	DOWN	-	Down Direction
2	LEFT	-	Left Direction
3	UP	-	Up Direction
4	RIGHT	-	Right Direction

#### 4.2. Example of Power Supply

It is recommended to apply a potentiometer for the contrast adjust due to the tolerance of the driving voltage and its temperature dependence.

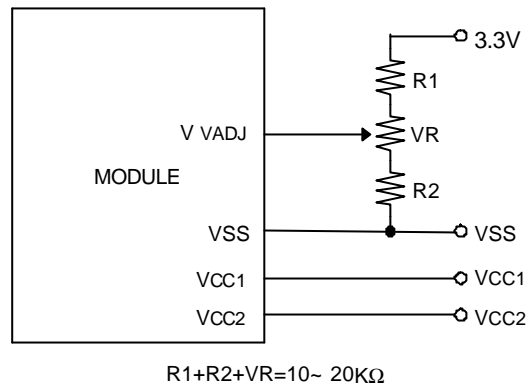

#### 4.3. Block Diagram

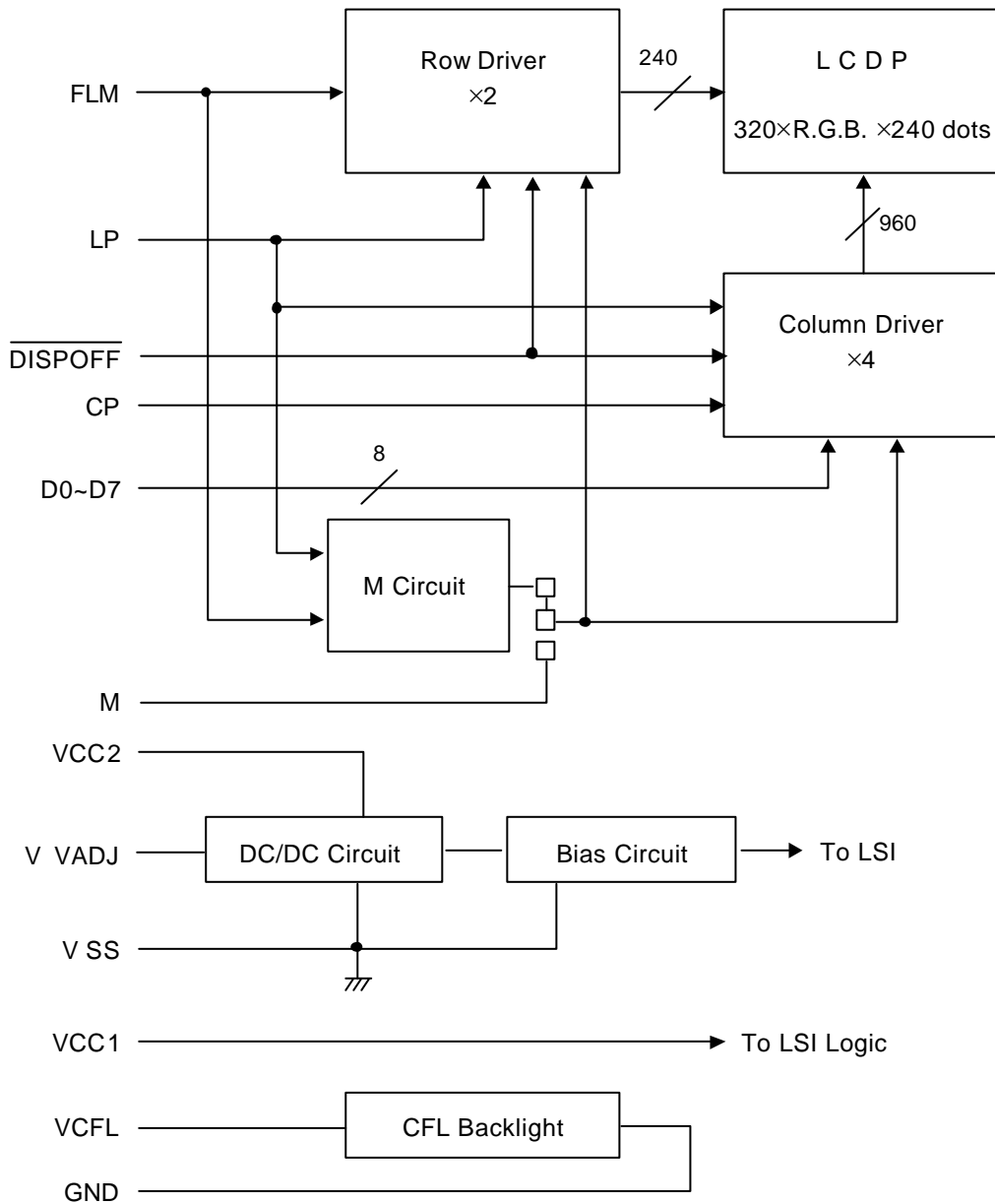

## 5. Test

No change on display and in operation under the following test condition.

Conditions: Unless otherwise specified, tests will be conducted under the following condition.

Temperature:  $20 \pm 5^\circ\text{C}$

Humidity :  $65 \pm 5\% \text{RH}$

tests will be not conducted under functioning state.

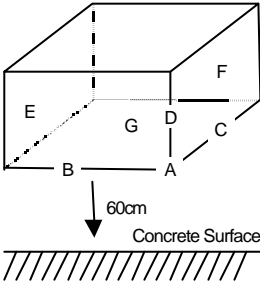
No.	Parameter	Conditions	Notes
1	High Temperature Operating	$50^\circ\text{C} \pm 2^\circ\text{C}$ , 96hrs (operation state)	
2	Low Temperature Operating	$0^\circ\text{C} \pm 2^\circ\text{C}$ , 96hrs (operation state)	1
3	High Temperature Storage	$60^\circ\text{C} \pm 2^\circ\text{C}$ , 96hrs	2
4	Low Temperature Storage	$-20^\circ\text{C} \pm 2^\circ\text{C}$ , 96hrs	1,2
5	Damp Proof Test	$40^\circ\text{C} \pm 2^\circ\text{C}$ , 90~95%RH, 96hrs	1,2
6	Vibration Test	Total fixed amplitude : 1.5mm Vibration Frequency : 10~55Hz One cycle 60 seconds to 3 directions of X, Y, Z for each 15 minutes	3
7	Shock Test	To be measured after dropping from 60cm high on the concrete surface in packing state. 	

Note 1 :No dew condensation to be observed.

Note 2 :The function test shall be conducted after 4 hours storage at the normal Temperature and humidity after removed from the test chamber.

Note 3 :Vibration test will be conducted to the product itself without putting it in a container.

## 6.Appearance Standards

### 6.1.Inspection conditions

The LCD shall be inspected under 40W white fluorescent light.

The distance between the eyes and the sample shall be more than 30cm.

All directions for inspecting the sample should be within 45°against perpendicular line.

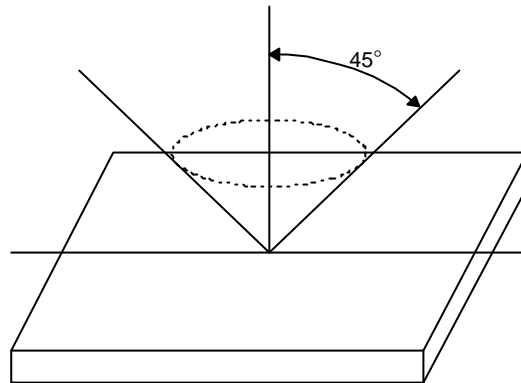

### 6.2.Definition of applicable Zones

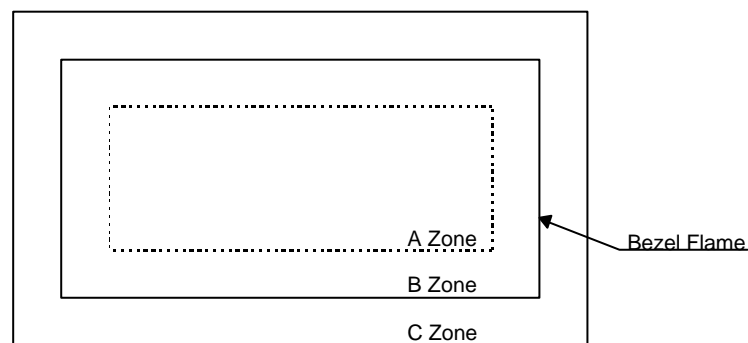

A Zone : Active display area

B Zone : Area from outside of "A Zone" to validity viewing area

C Zone : Rest parts

A Zone + B Zone = Validity viewing area

6.3. Standards

No.	Parameter	Criteria																												
1	Black and White Spots, Foreign Substances	(1) Round Shape <table border="1"> <thead> <tr> <th rowspan="2">Dimension (mm) \ Zone</th> <th colspan="3">Acceptable Number</th> </tr> <tr> <th>A</th> <th>B</th> <th>C</th> </tr> </thead> <tbody> <tr> <td>D ≤ 0.1</td> <td>*</td> <td>*</td> <td>*</td> </tr> <tr> <td>0.1 &lt; D ≤ 0.2</td> <td>3</td> <td>5</td> <td></td> </tr> <tr> <td>0.2 &lt; D ≤ 0.25</td> <td>2</td> <td>3</td> <td>*</td> </tr> <tr> <td>0.25 &lt; D ≤ 0.3</td> <td>0</td> <td>1</td> <td>*</td> </tr> <tr> <td>0.3 &lt; D</td> <td>0</td> <td>0</td> <td>*</td> </tr> </tbody> </table> <p>D = ( Long + Short ) / 2 * : Disregard</p>	Dimension (mm) \ Zone	Acceptable Number			A	B	C	D ≤ 0.1	*	*	*	0.1 < D ≤ 0.2	3	5		0.2 < D ≤ 0.25	2	3	*	0.25 < D ≤ 0.3	0	1	*	0.3 < D	0	0	*	
		Dimension (mm) \ Zone		Acceptable Number																										
A	B		C																											
D ≤ 0.1	*	*	*																											
0.1 < D ≤ 0.2	3	5																												
0.2 < D ≤ 0.25	2	3	*																											
0.25 < D ≤ 0.3	0	1	*																											
0.3 < D	0	0	*																											
(2) Line Shape <table border="1"> <thead> <tr> <th colspan="2">X(mm) \ Y(mm) \ Zone</th> <th colspan="3">Acceptable Number</th> </tr> <tr> <th>X(mm)</th> <th>Y(mm)</th> <th>A</th> <th>B</th> <th>C</th> </tr> </thead> <tbody> <tr> <td>-</td> <td>0.03 ≥ W</td> <td>*</td> <td>*</td> <td>*</td> </tr> <tr> <td>2.0 ≥ L</td> <td>0.05 ≥ W</td> <td>3</td> <td>3</td> <td>*</td> </tr> <tr> <td>1.0 ≥ L</td> <td>0.1 ≥ W</td> <td>3</td> <td>3</td> <td>*</td> </tr> <tr> <td>-</td> <td>0.1 &lt; W</td> <td colspan="3">In the same way (1)</td> </tr> </tbody> </table> <p>X : Length Y : Width * : Disregard Total defects shall not exceed 5.</p>	X(mm) \ Y(mm) \ Zone		Acceptable Number			X(mm)	Y(mm)	A	B	C	-	0.03 ≥ W	*	*	*	2.0 ≥ L	0.05 ≥ W	3	3	*	1.0 ≥ L	0.1 ≥ W	3	3	*	-	0.1 < W	In the same way (1)		
X(mm) \ Y(mm) \ Zone		Acceptable Number																												
X(mm)	Y(mm)	A	B	C																										
-	0.03 ≥ W	*	*	*																										
2.0 ≥ L	0.05 ≥ W	3	3	*																										
1.0 ≥ L	0.1 ≥ W	3	3	*																										
-	0.1 < W	In the same way (1)																												
2	Air Bubbles (between glass & polarizer)	<table border="1"> <thead> <tr> <th rowspan="2">Dimension (mm) \ Zone</th> <th colspan="3">Acceptable Number</th> </tr> <tr> <th>A</th> <th>B</th> <th>C</th> </tr> </thead> <tbody> <tr> <td>D ≤ 0.3</td> <td>*</td> <td>*</td> <td>*</td> </tr> <tr> <td>0.3 &lt; D ≤ 0.4</td> <td>3</td> <td>*</td> <td>*</td> </tr> <tr> <td>0.4 &lt; D ≤ 0.6</td> <td>2</td> <td>3</td> <td>*</td> </tr> <tr> <td>0.6 &lt; D</td> <td>0</td> <td>0</td> <td>*</td> </tr> </tbody> </table> <p>* : Disregard Total defects shall not exceed 3.</p>	Dimension (mm) \ Zone	Acceptable Number			A	B	C	D ≤ 0.3	*	*	*	0.3 < D ≤ 0.4	3	*	*	0.4 < D ≤ 0.6	2	3	*	0.6 < D	0	0	*					
Dimension (mm) \ Zone	Acceptable Number																													
	A	B	C																											
D ≤ 0.3	*	*	*																											
0.3 < D ≤ 0.4	3	*	*																											
0.4 < D ≤ 0.6	2	3	*																											
0.6 < D	0	0	*																											
3	The Shape of Dot	However, each pixel shall not remain more than one-third of the original pixel size.																												
4	Polarizer Scratches	Not to be conspicuous defects.																												
5	Polarizer Dirts	If the stains are removed easily from LCDP surface, the module is not defective.																												
6	Complex Foreign Substacbe Defects	Black spots, line shaped foreign substances or air bubbles between glass&polarizer shoud be 5pcs maxmum in total.																												
7	Distance between Differet Forrein Substacbe Defects	D ≤ 0.2 : 20mm or more 0.2 < D : 40mm or more																												



No.	Parameter	Criteria							
8	Black and White Spots With Gray Scale	Judge at the voltage which can be seen easily defect mode.							
		<table border="1"> <thead> <tr> <th data-bbox="603 241 909 342">Zone Dimension (mm)</th> <th data-bbox="909 241 1366 342">Acceptable Number</th> </tr> </thead> <tbody> <tr> <td data-bbox="603 342 909 387">D ≤ 0.3</td> <td data-bbox="909 342 1366 387">Disregard</td> </tr> <tr> <td data-bbox="603 387 909 439">0.3 &lt; D ≤ 0.6</td> <td data-bbox="909 387 1366 439">3 (1pc within φ30mm)</td> </tr> </tbody> </table>	Zone Dimension (mm)	Acceptable Number	D ≤ 0.3	Disregard	0.3 < D ≤ 0.6	3 (1pc within φ30mm)	
Zone Dimension (mm)	Acceptable Number								
D ≤ 0.3	Disregard								
0.3 < D ≤ 0.6	3 (1pc within φ30mm)								

## 7.Code System of Production Lot

The production lot of module is specified as follows.

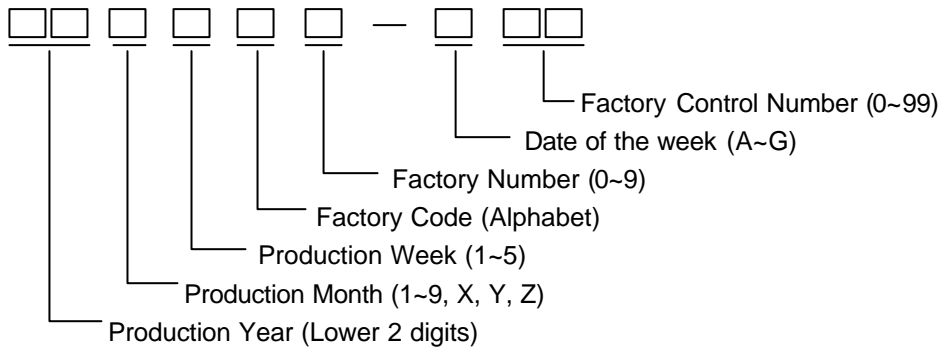

## 8.Type Number

The type number of module is specified as follows.

F-51900NCU-FW-AC

## 9.Applying Precautions

Please contact us when questions and/or new problems not specified in this Specifications arise.

## 10. Precautions Relating Product Handling

The Following precautions will guide you in handling our product correctly.

- 1) Liquid crystal display devices
  1. The liquid crystal display device panel used in the liquid crystal display module is made of plate glass. Avoid any strong mechanical shock. Should the glass break handle it with care.
  2. The polarizer adhering to the surface of the LCD is made of a soft material. Guard against scratching it.
- 2) Care of the liquid crystal display module against static electricity discharge.
  1. When working with the module, be sure to ground your body and any electrical equipment you may be using. We strongly recommend the use of anti static mats ( made of rubber ), to protect work tables against the hazards of electrical shock.
  2. Avoid the use of work clothing made of synthetic fibers. We recommend cotton clothing or other conductivity-treated fibers.
  3. Slowly and carefully remove the protective film from the LCD module, since this operation can generate static electricity.
- 3) When the LCD module alone must be stored for long periods of time:
  1. Protect the modules from high temperature and humidity.
  2. Keep the modules out of direct sunlight or direct exposure to ultraviolet rays.
  3. Protect the modules from excessive external forces.
- 4) Use the module with a power supply that is equipped with an overcurrent protector circuit, since the module is not provided with this protective feature.
- 5) Do not ingest the LCD fluid itself should it leak out of a damaged LCD module. Should hands or clothing come in contact with LCD fluid, wash immediately with soap.
- 6) Conductivity is not guaranteed for models that use metal holders where solder connections between the metal holder and the PCB are not used. Please contact us to discuss appropriate ways to assure conductivity.
- 7) For models which use CFL:
  1. High voltage of 1000V or greater is applied to the CFL cable connector area. Care should be taken not to touch connection areas to avoid burns.
  2. Protect CFL cables from rubbing against the unit and thus causing the wire jacket to become worn.
  3. The use of CFLs for extended periods of time at low temperatures will significantly shorten their service life.
- 8) For models which use touch panels:
  1. Do not stack up modules since they can be damaged by components on neighboring modules.
  2. Do not place heavy objects on top of the product. This could cause glass breakage.
- 9) For models which use COG, TAB, or COF:
  1. The mechanical strength of the product is low since the IC chip faces out unprotected from the rear. Be sure to protect the rear of the IC chip from external forces.
  2. Given the fact that the rear of the IC chip is left exposed, in order to protect the unit from electrical damage, avoid installation configurations in which the rear of the IC chip runs the risk of making any electrical contact.

10) Models which use flexible cable, heat seal, or TAB:

1. In order to maintain reliability, do not touch or hold by the connector area.
2. Avoid any bending, pulling, or other excessive force, which can result in broken connections.

11) In case of buffer material such as cushion / gasket is assembled into LCD module, it may have an adverse effect on connecting parts ( LCD panel-TCP / HEAT SEAL / FPC / etc., PCB-TCP / HEAT SEAL / FPC etc., TCP-HEAT SEAL, TCP-FPC, HEAT SEAL-FPC, etc.,) depending on its materials.

Please check and evaluate these materials carefully before use.

12) In case of acrylic plate is attached to front side of LCD panel, cloudiness ( very small cracks ) can occur on acrylic plate, being influenced by some components generated from polarizer film..

Please check and evaluate those acrylic materials carefully before use.

## 11. Warranty

This product has been manufactured to your company's specifications as a part for use in your company's general electronic products. It is guaranteed to perform according to delivery specifications. For any other use apart from general electronic equipment, we cannot take responsibility if the product is used in medical devices, nuclear power control equipment, aerospace equipment, fire and security systems, or any other applications in which there is a direct risk to human life and where extremely high levels of reliability are required. If the product is to be used in any of the above applications, we will need to enter into a separate product liability agreement.

1. We cannot accept responsibility for any defect, which may arise from additional manufacturing of the product (including disassembly and reassembly), after product delivery.
2. We cannot accept responsibility for any defect, which may arise after the application of strong external force to the product.
3. We cannot accept responsibility for any defect, which may arise due to the application of static electricity after the product has passed your company's acceptance inspection procedures.
4. When the product is in CFL models, CFL service life and brightness will vary According to the performance of the inverter used, leaks, etc. We cannot accept responsibility for product performance, reliability, or defect, which may arise.
5. We cannot accept responsibility for intellectual property of a third party, which may arise through the application of our product to your assembly with exception to those issues relating directly to the structure or method of manufacturing of our product.
6. Optrex will not be held responsible for any quality guarantee issue for defect products judged as Optrex-origin longer than 2 (two) years from Optrex production or 1(one) year from Optrex, Optrex America, Optrex Europe delivery which ever comes later.