HD74LV1GT08A

2-input AND Gate

HITACHI

ADE-205-328C (Z)
4th. Edition
April 2000

Description

The HD74LV1GT08A is high speed CMOS two input AND gate using silicon gate CMOS process. With CMOS low power dissipation, it provides high speed equivalent to LS-TTL series. The internal circuit of three stages construction with buffer provides wide noise margin and stable output. Low voltage and high speed operation is suitable for the battery powered products (e.g., notebook computers), and the low power consumption extends the battery life.

Features

- The basic gate function is lined up as hitachi uni logic series.
- Supplied on emboss taping for high speed automatic mounting.
- TTL compatible input level.
Supply voltage range : 4.5 to 5.5 V
Operating temperature range : -40 to +85°C
- All inputs V_{IH} (Max.) = 5.5 V (@ V_{CC} = 0 V to 5.5 V)
All outputs V_O (Max.) = 5.5 V (@ V_{CC} = 0 V)
- Output current ± 12 mA (@ V_{CC} = 4.5 V to 5.5 V)
- All the logical input has hysteresis voltage for the slow transition.

HD74LV1GT08A

Outline and Article Indication

- HD74LV1GT08A

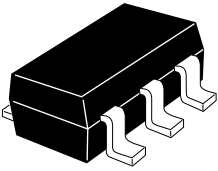

CMPAK-5

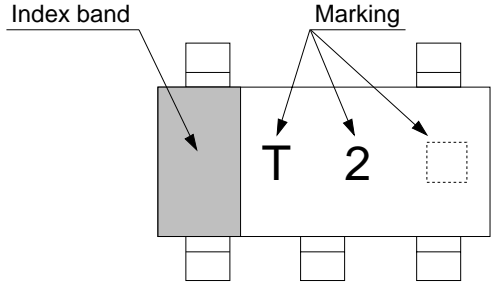

☐ = Control code
(— or blank)

Function Table

Inputs		Output Y
A	B	
L	L	L
H	L	L
L	H	L
H	H	H

H : High level

L : Low level

Pin Arrangement

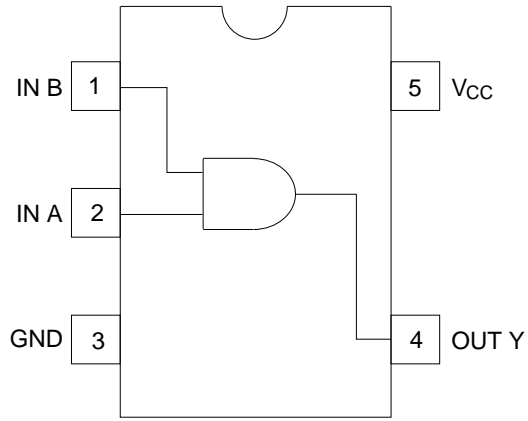

(Top view)

Absolute Maximum Ratings

Item	Symbol	Ratings	Unit	Test Conditions
Supply voltage	V_{CC}	-0.5 to 7.0	V	
Input voltage	V_{IN}	-0.5 to 7.0	V	
Output voltage	V_{OUT}	-0.5 to $V_{CC} + 0.5$ -0.5 to 7.0	V	Output : H or L V_{CC} : OFF
Input diode current	I_{IK}	-20	mA	
Output diode current	I_{OK}	± 50	mA	
Output current	I_{OUT}	± 25	mA	
V_{CC} , GND current	I_{CC} or I_{GND}	± 50	mA	
Power dissipation	P_T	200	mW	
Storage temperature	T_{stg}	-65 to 150	°C	

Recommended Operating Conditions

Item	Symbol	Ratings	Unit
Supply voltage	V_{CC}	4.5 to 5.5	V
Input voltage	V_{IN}	0 to 5.5	V
Output voltage	V_{OUT}	0 to V_{CC}	V
Operating temperature	T_{opr}	-40 to +85	°C
Input rise / fall time	t_r, t_f	0 to 20 ($V_{CC} = 4.5$ to 5.5 V)	ns

Electrical Characteristic

- $T_a = -40$ to 85°C

Item	Symbol	V_{CC} (V) *	Min	Typ	Max	Unit	Test condition
Input voltage	V_{IH}	4.5 to 5.5	2.0	—	—	V	
	V_{IL}	4.5 to 5.5	—	—	0.8		
Hysteresis voltage	V_H	5.0	—	0.15	—	V	$V_T^+ - V_T^-$
Output voltage	V_{OH}	Min to Max	$V_{CC}-0.1$	—	—	V	$I_{OH} = -50 \mu\text{A}$
		4.5	3.8	—	—		$I_{OH} = -12 \text{ mA}$
	V_{OL}	Min to Max	—	—	0.1		$I_{OL} = 50 \mu\text{A}$
		4.5	—	—	0.55		$I_{OL} = 12 \text{ mA}$
Input current	I_{IN}	0 to 5.5	—	—	± 1	μA	$V_{IN} = 5.5 \text{ V}$ or GND
Quiescent supply current	I_{CC}	5.5	—	—	10	μA	$V_{IN} = V_{CC}$ or GND, $I_O = 0$
	ΔI_{CC}	5.5	—	—	1.5	mA	One input $V_{IN} = 3.4 \text{ V}$, other input V_{CC} or GND
Output leakage current	I_{OFF}	0	—	—	5	μA	$V_O = 5.5 \text{ V}$
Input capacitance	C_{IN}	5.0	—	2.5	—	pF	$V_{IN} = V_{CC}$ or GND

Note: For conditions shown as Min or Max, use the appropriate values under recommended operating conditions.

Switching Characteristics

- $V_{CC} = 5.0 \pm 0.5$ V

Item	Symbol	$T_a = 25^\circ\text{C}$			$T_a = -40$ to 85°C		Unit	Test Conditions	FROM (Input)	TO (Output)
		Min	Typ	Max	Min	Max				
Propagation delay time	t_{PLH}	—	5.0	6.9	1.0	8.0	ns	$C_L = 15$ pF	A or B	Y
	t_{PHL}	—	5.5	7.9	1.0	9.0		$C_L = 50$ pF		

Operating Characteristics

- $C_L = 50$ pF

Item	Symbol	V_{CC} (V)	$T_a = 25^\circ\text{C}$			Unit	Test Conditions
			Min	Typ	Max		
Power dissipation capacitance	C_{PD}	5.0	—	10.0	—	pF	$f = 10$ MHz

Test Circuit

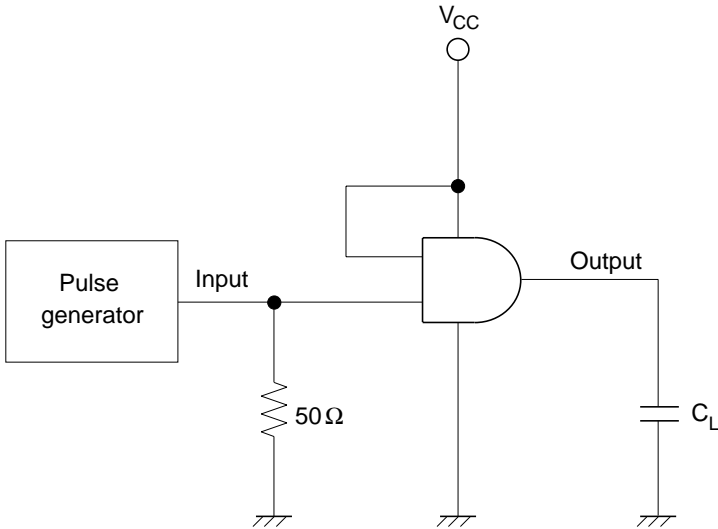

Note: Operating current test time, output is open.

• Waveforms

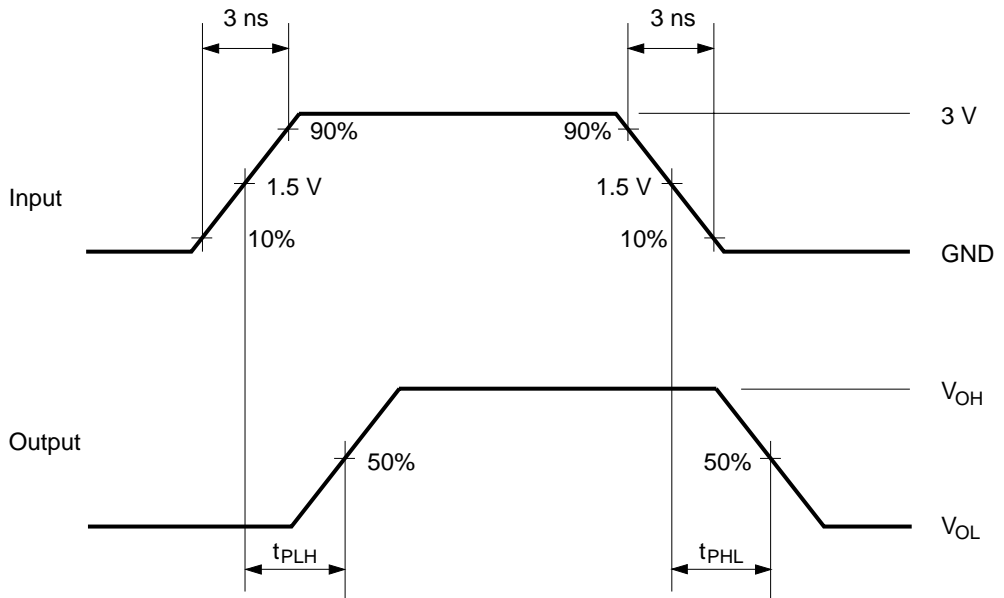

Package Dimensions

Unit : mm

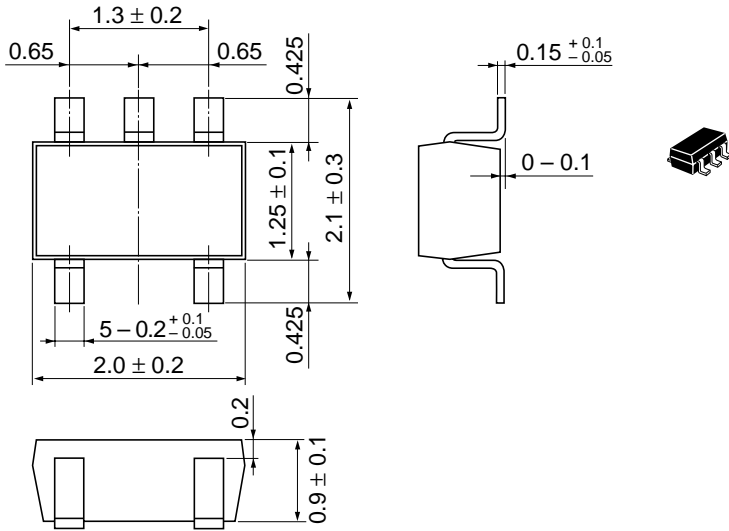

Hitachi Code	CMPAK-5
JEDEC	—
EIAJ	—
Weight (reference value)	0.006 g

Cautions

1. Hitachi neither warrants nor grants licenses of any rights of Hitachi's or any third party's patent, copyright, trademark, or other intellectual property rights for information contained in this document. Hitachi bears no responsibility for problems that may arise with third party's rights, including intellectual property rights, in connection with use of the information contained in this document.
2. Products and product specifications may be subject to change without notice. Confirm that you have received the latest product standards or specifications before final design, purchase or use.
3. Hitachi makes every attempt to ensure that its products are of high quality and reliability. However, contact Hitachi's sales office before using the product in an application that demands especially high quality and reliability or where its failure or malfunction may directly threaten human life or cause risk of bodily injury, such as aerospace, aeronautics, nuclear power, combustion control, transportation, traffic, safety equipment or medical equipment for life support.
4. Design your application so that the product is used within the ranges guaranteed by Hitachi particularly for maximum rating, operating supply voltage range, heat radiation characteristics, installation conditions and other characteristics. Hitachi bears no responsibility for failure or damage when used beyond the guaranteed ranges. Even within the guaranteed ranges, consider normally foreseeable failure rates or failure modes in semiconductor devices and employ systemic measures such as fail-safes, so that the equipment incorporating Hitachi product does not cause bodily injury, fire or other consequential damage due to operation of the Hitachi product.
5. This product is not designed to be radiation resistant.
6. No one is permitted to reproduce or duplicate, in any form, the whole or part of this document without written approval from Hitachi.
7. Contact Hitachi's sales office for any questions regarding this document or Hitachi semiconductor products.

HITACHI

Hitachi, Ltd.

Semiconductor & Integrated Circuits.
 Nippon Bldg., 2-6-2, Ohte-machi, Chiyoda-ku, Tokyo 100-0004, Japan
 Tel: Tokyo (03) 3270-2111 Fax: (03) 3270-5109

URL North America : <http://semiconductor.hitachi.com/>
 Europe : <http://www.hitachi-eu.com/hel/ecg>
 Asia (Singapore) : <http://www.has.hitachi.com.sg/grp3/sicd/index.htm>
 Asia (Taiwan) : http://www.hitachi.com.tw/E/Product/SICD_Frame.htm
 Asia (HongKong) : <http://www.hitachi.com.hk/eng/bo/grp3/index.htm>
 Japan : <http://www.hitachi.co.jp/Sicd/index.htm>

For further information write to:

Hitachi Semiconductor
 (America) Inc.
 179 East Tasman Drive,
 San Jose, CA 95134
 Tel: <1> (408) 433-1990
 Fax: <1>(408) 433-0223

Hitachi Europe GmbH
 Electronic components Group
 Dornacher StraÙe 3
 D-85622 Feldkirchen, Munich
 Germany
 Tel: <49> (89) 9 9180-0
 Fax: <49> (89) 9 29 30 00

Hitachi Europe Ltd.
 Electronic Components Group.
 Whitebrook Park
 Lower Cookham Road
 Maidenhead
 Berkshire SL6 8YA, United Kingdom
 Tel: <44> (1628) 585000
 Fax: <44> (1628) 778322

Hitachi Asia Pte. Ltd.
 16 Collyer Quay #20-00
 Hitachi Tower
 Singapore 049318
 Tel: 535-2100
 Fax: 535-1533

Hitachi Asia Ltd.
 Taipei Branch Office
 3F, Hung Kuo Building, No.167,
 Tun-Hwa North Road, Taipei (105)
 Tel: <886> (2) 2718-3666
 Fax: <886> (2) 2718-8180

Hitachi Asia (Hong Kong) Ltd.
 Group III (Electronic Components)
 7/F., North Tower, World Finance Centre,
 Harbour City, Canton Road, Tsim Sha Tsui,
 Kowloon, Hong Kong
 Tel: <852> (2) 735 9218
 Fax: <852> (2) 730 0281
 Telex: 40815 HITEC HX

Copyright ' Hitachi, Ltd., 2000. All rights reserved. Printed in Japan.