

SOLOMON SYSTECH
SEMICONDUCTOR TECHNICAL DATA

SSD1788

Advance Information

98 RGB x 68 CSTN
LCD Segment / Common COLOR Driver with Controller

This document contains information on a new product. Specifications and information herein are subject to change without notice.

<http://www.solomon-systech.com>

SSD1788 Series | Rev 1.2 | P 1/71 | Jul 2004

Copyright © 2003 **Solomon Systech Limited**



TABLE OF CONTENTS

1	GENERAL DESCRIPTION	5
2	FEATURES	5
3	ORDERING INFORMATION	5
4	BLOCK DIAGRAM	6
5	DIE PAD FLOOR PLAN	7
6	PIN DESCRIPTION.....	14
7	FUNCTIONAL BLOCK DESCRIPTIONS.....	17
8	COMMAND TABLE	24
9	COMMAND DESCRIPTIONS	33
10	MAXIMUM RATINGS	53
11	DC CHARACTERISTICS.....	54
12	AC CHARACTERISTICS.....	56
13	APPLICATION EXAMPLES.....	67
14	PACKAGE INFORMATION.....	70

www.DataSheet4U.com

TABLE OF TABLES

Table 1 - Ordering Information	5
Table 2 - SSD1788 Series Bump Die Pad Coordinates	8
Table 3 - $V_{OUT} > V_{L5} > V_{L4} > V_{L3} > V_{L2} > V_{SS}$ Relationship	15
Table 4 - Data bus selection modes	18
Table 5 - Command Table	24
Table 6 - Read Command Table	31
Table 7 - RAM arrangements of 8-levels gray scale mode	33
Table 8 - RAM arrangements of 16-levels gray scale mode	34
Table 9 - RGB Arrangement modes	37
Table 10 - Gray scale selection mode	37
Table 11 - Area scrolling selection modes	39
Table 12 - Maximum Ratings	53
Table 13 - DC Characteristics	54
Table 14 - AC Characteristics	56
Table 15 - Parallel 6800-series Interface Timing Characteristics	57
Table 16 - Parallel 8080-series Interface Timing Characteristics	58
Table 17 - Parallel 6800-series Interface Timing Characteristics	59
Table 18 - Parallel 8080-series Interface Timing Characteristics	60
Table 19 - 4-Wires Serial Timing Characteristics	61
Table 20 - 3-Wires Serial Timing Characteristics	62
Table 21 - 4-Wires Serial Timing Characteristics	63
Table 22 - 3-Wires Serial Timing Characteristics	64
Table 23 - Power Up/Down Timing Characteristics	65

www.DataSheet4U.com

TABLE OF FIGURES

Figure 1 - SSD1788 Block Diagram	6
Figure 2 - SSD1788 Die Pad Floor Plan	7
Figure 3 - Display Data	17
Figure 4 - Display Data RAM Map	21
Figure 5 - SSD1788 Hardware Configurations	22
Figure 6 - Oscillator structural block diagram	22
Figure 7 - column and page scan direction of 8-level gray scale mode	35
Figure 8 - column and page scan direction of 16-level gray scale mode	36
Figure 9 - Example of Normal or Reverse page/column/ scan directions	36
Figure 10 - Examples: 8 gray-scale display arrangement	37
Figure 11 - Area scrolling selection modes	39
Figure 12 - GDDRAM updates for area scrolling	40
Figure 13 - Example of Specified Center Scroll Mode	41
Figure 14 - Contrast Control Flow Set Segment Re-map	42
Figure 15 - Contrast Control Voltage Range Curve	43
Figure 16 - Partial display mode	44
Figure 17 - OTP programming circuitry	49
Figure 18 - Flow chart of OTP programming Procedure	50
Figure 19 - Parallel 6800-series Interface Timing Characteristics (PS0 = H, PS1 = H)	57
Figure 20 - Parallel 8080-series Interface Timing Characteristics (PS0 = H, PS1 = L)	58
Figure 21 - Parallel 6800-series Interface Timing Characteristics (PS0 = H, PS1 = H)	59
Figure 22 - Parallel 8080-series Interface Timing Characteristics (PS0 = H, PS1 = L)	60
Figure 23 - 4-Wires Serial Timing Characteristics (PS0 = L, PS1 =L)	61
Figure 24 - 3-Wires Serial Timing Characteristics (PS0 = L, PS1 =H)	62
Figure 25 - 4-Wires Serial Timing Characteristics (PS0 = L, PS1 =L)	63
Figure 26 - 3- Wires Serial Timing Characteristics (PS0 = L, PS1 =H)	64
Figure 27 - Power Up	65
Figure 28 - Initial Code Timing Chart	66
Figure 29 - Power save / power up / power off timing chart	66
Figure 30 - Application Examples	67

1 General Description

SSD1788 is a single-chip CMOS color STN LCD driver with controller for dot-matrix graphic liquid crystal display system. SSD1788 consists of 362 high voltage driving output pins for driving maximum 98 RGB Segments and 68 Commons.

SSD1788 consists of 294 (98 RGB) x 68 x 4 bits Graphic Display Data RAM (GDDRAM). Data/Commands are sent from common MCU through 8-bit 6800-series / 8080-series compatible Parallel Interface or 3-wires / 4-wires Serial Peripheral Interface by pins selection.

SSD1788 embeds DC-DC Converter, On-Chip Oscillator and Bias Divider so as to reduce the number of external components. With the advanced design, low power consumption, stable LCD operating voltage and flexible die package layout, SSD1788 is suitable for any portable battery-driven applications requiring long operation period with compact size.

2 FEATURES

- Power Supply: $V_{DD} = 2.4V - 3.6V$
 $V_{DDIO} = 1.2V - 3.6V$
 $V_{CI} = 2.4V - 3.6V$
- LCD Driving Output Voltage: 13.5V
- Low Current Sleep Mode
- Maximum display size: 98 RGB columns by 68 rows.
- Maximum display colors: 256 colors or 4096 colors graphical display
- 256-colors Position Control and simultaneous RGB display control
- 8-bit 6800-series / 8080-series Parallel Interface, 3-wires /4-wires Serial Peripheral Interface
- On-Chip 294 (98 RGB) X 68 x 4 = 79,968 bits Graphic Display Data RAM
- Programmable partial display function
- Column Re-mapping and RAM Page scan direction control
- Software selection on Center Screen Scrolling, Top Screen Scrolling, Bottom Screen Scrolling and Whole Screen Scrolling
- On-Chip Voltage Generator or External LCD Driving Power Supply Selectable
- 3X/ 4X / 5X / 6X On-Chip DC-DC Converter with internal flying capacitor
- 64 Levels Internal Contrast Control
- Programmable LCD Driving Voltage Temperature Compensation Coefficients
- On-Chip Bias Divider with internal flying capacitor (expect V_{OUT})
- Programmable drive duty ratio: 1 /8 to 1 /68
- On-Chip Oscillator
- 2-D Graphic Acceleration Engine
- Non-Volatile Memory (OTP) for calibration

3 ORDERING INFORMATION

Ordering Part Number	SEG	COM	Package Form	Reference	Remark
SSD1788Z	98x3 (294)	68	Gold Bump Die	Figure 2 on Page 7	

Table 1 - Ordering Information

4 BLOCK DIAGRAM

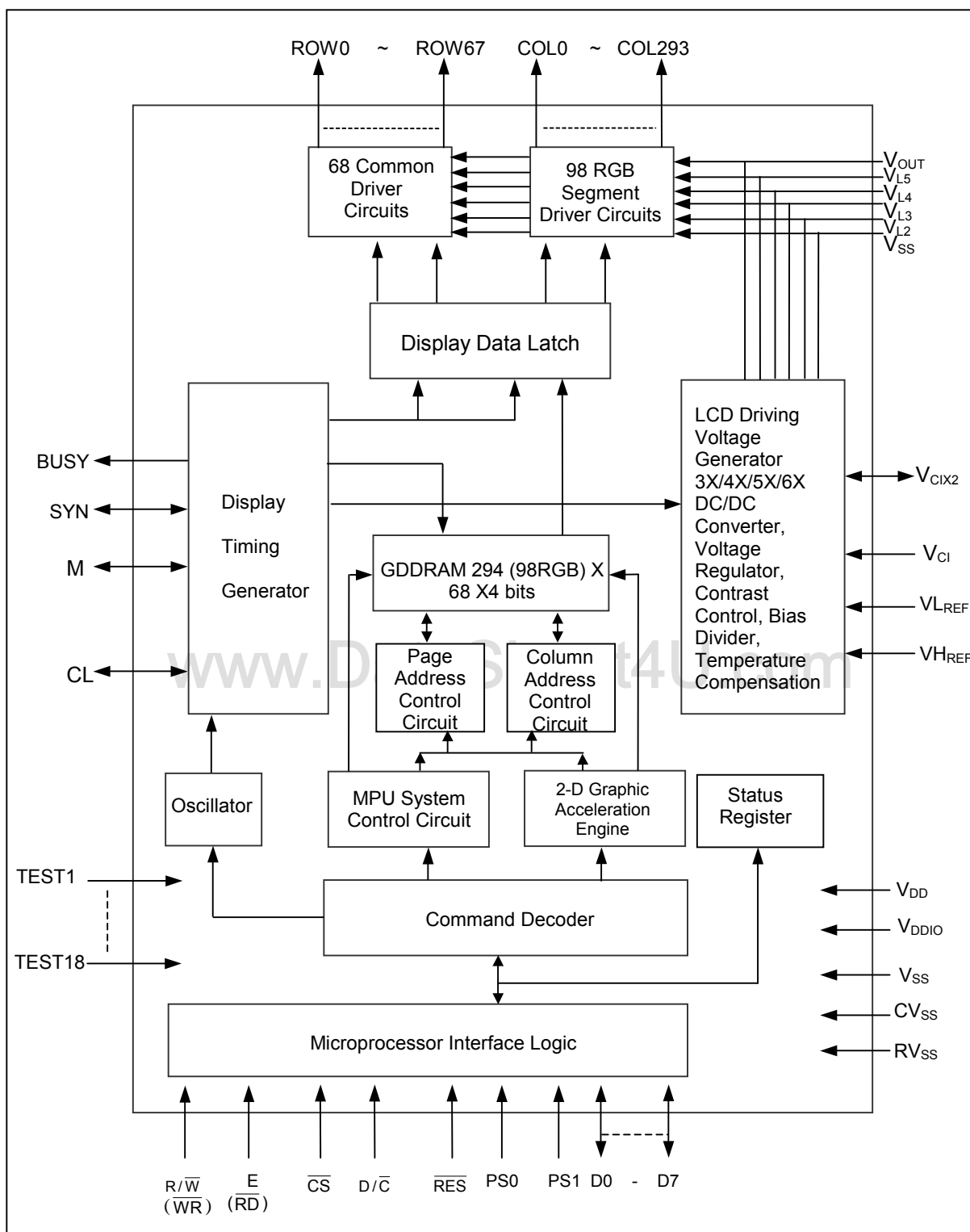
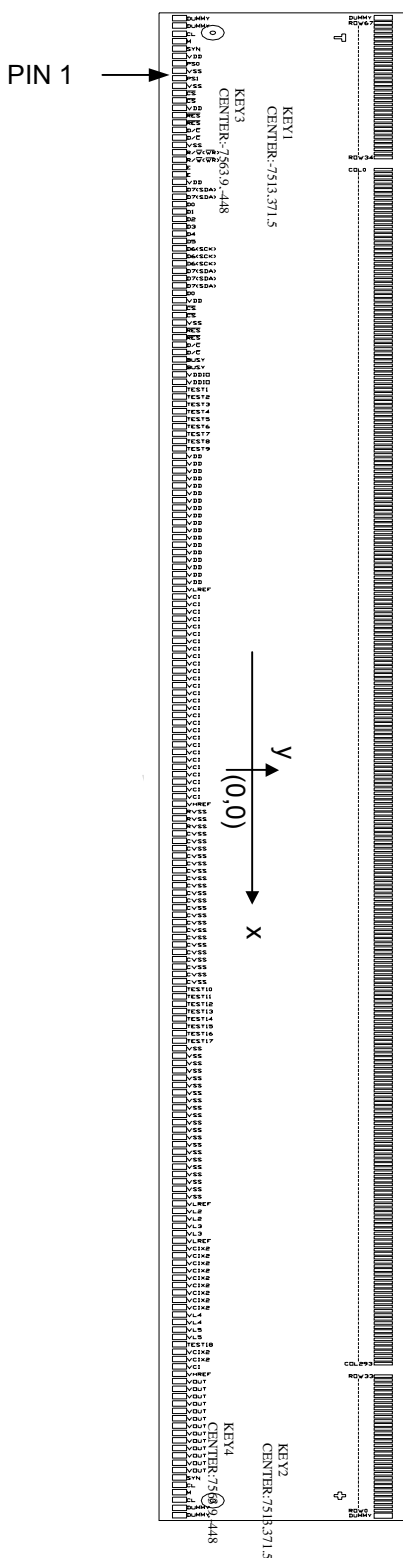

Figure 1 - SSD1788 Block Diagram

5 DIE PAD FLOOR PLAN



Note:

1. Diagram showing the die face up.
2. Coordinates are reference to center of the chip.
3. Unit of coordinates and Size of all alignment marks are in μm .
4. All alignment keys do not contain gold bump.

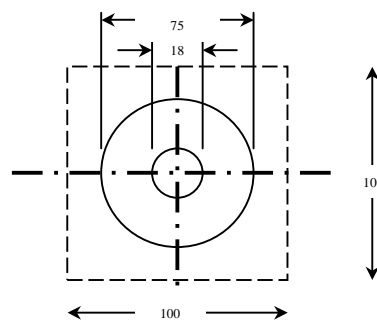
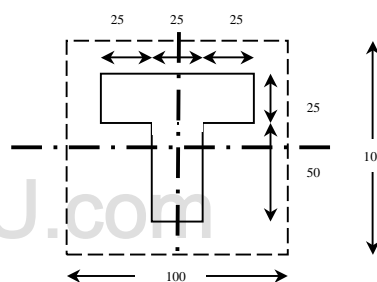
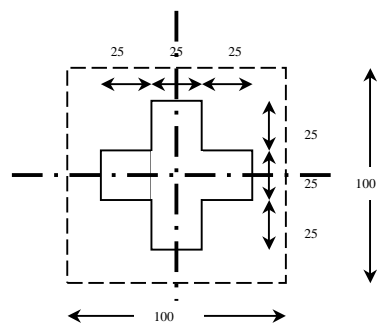

Die Size	15.68 x 1.65	mm^2
Die Thickness	457±25	μm
Typical Bump Height	15	μm
Bump Co-planarity (within die)	<3	μm

Figure 2 - SSD1788 Die Pad Floor Plan

Table 2 - SSD1788 Series Bump Die Pad Coordinates (Bump center)

Pad #	Signal	X-pos	Y-pos	Pad #	Signal	X-pos	Y-pos	Pad #	Signal	X-pos	Y-pos
1	DUMMY	-7714.5	-663	51	TEST1	-3891.3	-663	101	V _{Cl}	-76.3	-663
2	DUMMY	-7638.2	-663	52	TEST2	-3815	-663	102	V _{Cl}	0	-663
3	CL	-7553.7	-663	53	TEST3	-3738.7	-663	103	V _{Cl}	76.3	-663
4	M	-7477.4	-663	54	TEST4	-3662.4	-663	104	V _{Cl}	152.6	-663
5	SYN	-7401.1	-663	55	TEST5	-3586.1	-663	105	V _{Cl}	228.9	-663
6	V _{DD}	-7324.8	-663	56	TEST6	-3509.8	-663	106	V _{Cl}	305.2	-663
7	PS0	-7248.5	-663	57	TEST7	-3433.5	-663	107	VH _{REF}	381.5	-663
8	V _{SS}	-7172.2	-663	58	TEST8	-3357.2	-663	108	RV _{SS}	457.8	-663
9	PS1	-7095.9	-663	59	TEST9	-3280.9	-663	109	RV _{SS}	534.1	-663
10	V _{SS}	-7019.6	-663	60	V _{DD}	-3204.6	-663	110	RV _{SS}	610.4	-663
11	$\overline{\text{CS}}$	-6943.3	-663	61	V _{DD}	-3128.3	-663	111	CV _{SS}	686.7	-663
12	$\overline{\text{CS}}$	-6867	-663	62	V _{DD}	-3052	-663	112	CV _{SS}	763	-663
13	V _{DD}	-6790.7	-663	63	V _{DD}	-2975.7	-663	113	CV _{SS}	839.3	-663
14	$\overline{\text{RES}}$	-6714.4	-663	64	V _{DD}	-2899.4	-663	114	CV _{SS}	915.6	-663
15	$\overline{\text{RES}}$	-6638.1	-663	65	V _{DD}	-2823.1	-663	115	CV _{SS}	991.9	-663
16	D/C	-6561.8	-663	66	V _{DD}	-2746.8	-663	116	CV _{SS}	1068.2	-663
17	D/C	-6485.5	-663	67	V _{DD}	-2670.5	-663	117	CV _{SS}	1144.5	-663
18	V _{SS}	-6409.2	-663	68	V _{DD}	-2594.2	-663	118	CV _{SS}	1220.8	-663
19	R/W (WR)	-6332.9	-663	69	V _{DD}	-2517.9	-663	119	CV _{SS}	1297.1	-663
20	R/W (WR)	-6256.6	-663	70	V _{DD}	-2441.6	-663	120	CV _{SS}	1373.4	-663
21	E ($\overline{\text{RD}}$)	-6180.3	-663	71	V _{DD}	-2365.3	-663	121	CV _{SS}	1449.7	-663
22	E ($\overline{\text{RD}}$)	-6104	-663	72	V _{DD}	-2289	-663	122	CV _{SS}	1526	-663
23	V _{DD}	-6027.7	-663	73	V _{DD}	-2212.7	-663	123	CV _{SS}	1602.3	-663
24	D7 (SDA)	-5951.4	-663	74	V _{DD}	-2136.4	-663	124	CV _{SS}	1678.6	-663
25	D7 (SDA)	-5875.1	-663	75	V _{DD}	-2060.1	-663	125	CV _{SS}	1754.9	-663
26	D0	-5798.8	-663	76	V _{DD}	-1983.8	-663	126	CV _{SS}	1831.2	-663
27	D1	-5722.5	-663	77	V _{DD}	-1907.5	-663	127	CV _{SS}	1907.5	-663
28	D2	-5646.2	-663	78	VL _{REF}	-1831.2	-663	128	CV _{SS}	1983.8	-663
29	D3	-5569.9	-663	79	V _{Cl}	-1754.9	-663	129	CV _{SS}	2060.1	-663
30	D4	-5493.6	-663	80	V _{Cl}	-1678.6	-663	130	CV _{SS}	2136.4	-663
31	D5	-5417.3	-663	81	V _{Cl}	-1602.3	-663	131	CV _{SS}	2212.7	-663
32	D6 (SCK)	-5341	-663	82	V _{Cl}	-1526	-663	132	TEST10	2289	-663
33	D6 (SCK)	-5264.7	-663	83	V _{Cl}	-1449.7	-663	133	TEST11	2365.3	-663
34	D6 (SCK)	-5188.4	-663	84	V _{Cl}	-1373.4	-663	134	TEST12	2441.6	-663
35	D7 (SDA)	-5112.1	-663	85	V _{Cl}	-1297.1	-663	135	TEST13	2517.9	-663
36	D7 (SDA)	-5035.8	-663	86	V _{Cl}	-1220.8	-663	136	TEST14	2594.2	-663
37	D7 (SDA)	-4959.5	-663	87	V _{Cl}	-1144.5	-663	137	TEST15	2670.5	-663
38	D0	-4883.2	-663	88	V _{Cl}	-1068.2	-663	138	TEST16	2746.8	-663
39	V _{DD}	-4806.9	-663	89	V _{Cl}	-991.9	-663	139	TEST17	2823.1	-663
40	$\overline{\text{CS}}$	-4730.6	-663	90	V _{Cl}	-915.6	-663	140	V _{SS}	2899.4	-663
41	$\overline{\text{CS}}$	-4654.3	-663	91	V _{Cl}	-839.3	-663	141	V _{SS}	2975.7	-663
42	V _{SS}	-4578	-663	92	V _{Cl}	-763	-663	142	V _{SS}	3052	-663
43	$\overline{\text{RES}}$	-4501.7	-663	93	V _{Cl}	-686.7	-663	143	V _{SS}	3128.3	-663
44	$\overline{\text{RES}}$	-4425.4	-663	94	V _{Cl}	-610.4	-663	144	V _{SS}	3204.6	-663
45	D/C	-4349.1	-663	95	V _{Cl}	-534.1	-663	145	V _{SS}	3280.9	-663
46	D/C	-4272.8	-663	96	V _{Cl}	-457.8	-663	146	V _{SS}	3357.2	-663
47	BUSY	-4196.5	-663	97	V _{Cl}	-381.5	-663	147	V _{SS}	3433.5	-663
48	BUSY	-4120.2	-663	98	V _{Cl}	-305.2	-663	148	V _{SS}	3509.8	-663
49	V _{DDIO}	-4043.9	-663	99	V _{Cl}	-228.9	-663	149	V _{SS}	3586.1	-663
50	V _{DDIO}	-3967.6	-663	100	V _{Cl}	-152.6	-663	150	V _{SS}	3662.4	-663

Pad #	Signal	X-pos	Y-pos	Pad #	Signal	X-pos	Y-pos	Pad #	Pad Name	Signal	Color	X-pos	Y-pos
151	V _{SS}	3738.7	-663	201	CL	7553.7	-663	239	COL293	SEG97	B	6153	651
152	V _{SS}	3815	-663	202	DUMMY	7638.2	-663	240	COL292		G	6111	651
153	V _{SS}	3891.3	-663	203	DUMMY	7714.5	-663	241	COL291		R	6069	651
154	V _{SS}	3967.6	-663	204	DUMMY	7718.5	651	242	COL290	SEG96	B	6027	651
155	V _{SS}	4043.9	-663	205	ROW0	7665	651	243	COL289		G	5985	651
156	V _{SS}	4120.2	-663	206	ROW1	7623	651	244	COL288		R	5943	651
157	V _{SS}	4196.5	-663	207	ROW2	7581	651	245	COL287	SEG95	B	5901	651
158	V _{SS}	4272.8	-663	208	ROW3	7539	651	246	COL286		G	5859	651
159	V _{SS}	4349.1	-663	209	ROW4	7497	651	247	COL285		R	5817	651
160	V _{SS}	4425.4	-663	210	ROW5	7455	651	248	COL284	SEG94	B	5775	651
161	V _{LREF}	4501.7	-663	211	ROW6	7413	651	249	COL283		G	5733	651
162	V _{L2}	4578	-663	212	ROW7	7371	651	250	COL282		R	5691	651
163	V _{L2}	4654.3	-663	213	ROW8	7329	651	251	COL281	SEG93	B	5649	651
164	V _{L3}	4730.6	-663	214	ROW9	7287	651	252	COL280		G	5607	651
165	V _{L3}	4806.9	-663	215	ROW10	7245	651	253	COL279		R	5565	651
166	V _{LREF}	4883.2	-663	216	ROW11	7203	651	254	COL278	SEG92	B	5523	651
167	V _{CIX2}	4959.5	-663	217	ROW12	7161	651	255	COL277		G	5481	651
168	V _{CIX2}	5035.8	-663	218	ROW13	7119	651	256	COL276		R	5439	651
169	V _{CIX2}	5112.1	-663	219	ROW14	7077	651	257	COL275	SEG91	B	5397	651
170	V _{CIX2}	5188.4	-663	220	ROW15	7035	651	258	COL274		G	5355	651
171	V _{CIX2}	5264.7	-663	221	ROW16	6993	651	259	COL273		R	5313	651
172	V _{CIX2}	5341	-663	222	ROW17	6951	651	260	COL272	SEG90	B	5271	651
173	V _{CIX2}	5417.3	-663	223	ROW18	6909	651	261	COL271		G	5229	651
174	V _{CIX2}	5493.6	-663	224	ROW19	6867	651	262	COL270		R	5187	651
175	V _{CIX2}	5569.9	-663	225	ROW20	6825	651	263	COL269	SEG89	B	5145	651
176	V _{L4}	5646.2	-663	226	ROW21	6783	651	264	COL268		G	5103	651
177	V _{L4}	5722.5	-663	227	ROW22	6741	651	265	COL267		R	5061	651
178	V _{L5}	5798.8	-663	228	ROW23	6699	651	266	COL266	SEG88	B	5019	651
179	V _{L5}	5875.1	-663	229	ROW24	6657	651	267	COL265		G	4977	651
180	TEST18	5951.4	-663	230	ROW25	6615	651	268	COL264		R	4935	651
181	V _{CIX2}	6027.7	-663	231	ROW26	6573	651	269	COL263	SEG87	B	4893	651
182	V _{CIX2}	6104	-663	232	ROW27	6531	651	270	COL262		G	4851	651
183	V _{Cl}	6180.3	-663	233	ROW28	6489	651	271	COL261		R	4809	651
184	V _{HREF}	6256.6	-663	234	ROW29	6447	651	272	COL260	SEG86	B	4767	651
185	V _{OUT}	6332.9	-663	235	ROW30	6405	651	273	COL259		G	4725	651
186	V _{OUT}	6409.2	-663	236	ROW31	6363	651	274	COL258		R	4683	651
187	V _{OUT}	6485.5	-663	237	ROW32	6321	651	275	COL257	SEG85	B	4641	651
188	V _{OUT}	6561.8	-663	238	ROW33	6279	651	276	COL256		G	4599	651
189	V _{OUT}	6638.1	-663					277	COL255		R	4557	651
190	V _{OUT}	6714.4	-663					278	COL254	SEG84	B	4515	651
191	V _{OUT}	6790.7	-663					279	COL253		G	4473	651
192	V _{OUT}	6867	-663					280	COL252		R	4431	651
193	V _{OUT}	6943.3	-663					281	COL251	SEG83	B	4389	651
194	V _{OUT}	7019.6	-663					282	COL250		G	4347	651
195	V _{OUT}	7095.9	-663					283	COL249		R	4305	651
196	V _{OUT}	7172.2	-663					284	COL248	SEG82	B	4263	651
197	V _{OUT}	7248.5	-663					285	COL247		G	4221	651
198	SYN	7324.8	-663					286	COL246		R	4179	651
199	CL	7401.1	-663										
200	M	7477.4	-663										

Pad #	Pad Name	Signal	Color	X-pos	Y-pos	Pad #	Pad Name	Signal	Color	X-pos	Y-pos
287	COL245	SEG81	B	4137	651	335	COL197	SEG65	B	2121	651
288	COL244		G	4095	651	336	COL196		G	2079	651
289	COL243		R	4053	651	337	COL195		R	2037	651
290	COL242	SEG80	B	4011	651	338	COL194	SEG64	B	1995	651
291	COL241		G	3969	651	339	COL193		G	1953	651
292	COL240		R	3927	651	340	COL192		R	1911	651
293	COL239	SEG79	B	3885	651	341	COL191	SEG63	B	1869	651
294	COL238		G	3843	651	342	COL190		G	1827	651
295	COL237		R	3801	651	343	COL189		R	1785	651
296	COL236	SEG78	B	3759	651	344	COL188	SEG62	B	1743	651
297	COL235		G	3717	651	345	COL187		G	1701	651
298	COL234		R	3675	651	346	COL186		R	1659	651
299	COL233	SEG77	B	3633	651	347	COL185	SEG61	B	1617	651
300	COL232		G	3591	651	348	COL184		G	1575	651
301	COL231		R	3549	651	349	COL183		R	1533	651
302	COL230	SEG76	B	3507	651	350	COL182	SEG60	B	1491	651
303	COL229		G	3465	651	351	COL181		G	1449	651
304	COL228		R	3423	651	352	COL180		R	1407	651
305	COL227	SEG75	B	3381	651	353	COL179	SEG59	B	1365	651
306	COL226		G	3339	651	354	COL178		G	1323	651
307	COL225		R	3297	651	355	COL177		R	1281	651
308	COL224	SEG74	B	3255	651	356	COL176	SEG58	B	1239	651
309	COL223		G	3213	651	357	COL175		G	1197	651
310	COL222		R	3171	651	358	COL174		R	1155	651
311	COL221	SEG73	B	3129	651	359	COL173	SEG57	B	1113	651
312	COL220		G	3087	651	360	COL172		G	1071	651
313	COL219		R	3045	651	361	COL171		R	1029	651
314	COL218	SEG72	B	3003	651	362	COL170	SEG56	B	987	651
315	COL217		G	2961	651	363	COL169		G	945	651
316	COL216		R	2919	651	364	COL168		R	903	651
317	COL215	SEG71	B	2877	651	365	COL167	SEG55	B	861	651
318	COL214		G	2835	651	366	COL166		G	819	651
319	COL213		R	2793	651	367	COL165		R	777	651
320	COL212	SEG70	B	2751	651	368	COL164	SEG54	B	735	651
321	COL211		G	2709	651	369	COL163		G	693	651
322	COL210		R	2667	651	370	COL162		R	651	651
323	COL209	SEG69	B	2625	651	371	COL161	SEG53	B	609	651
324	COL208		G	2583	651	372	COL160		G	567	651
325	COL207		R	2541	651	373	COL159		R	525	651
326	COL206	SEG68	B	2499	651	374	COL158	SEG52	B	483	651
327	COL205		G	2457	651	375	COL157		G	441	651
328	COL204		R	2415	651	376	COL156		R	399	651
329	COL203	SEG67	B	2373	651	377	COL155	SEG51	B	357	651
330	COL202		G	2331	651	378	COL154		G	315	651
331	COL201		R	2289	651	379	COL153		R	273	651
332	COL200	SEG66	B	2247	651	380	COL152	SEG50	B	231	651
333	COL199		G	2205	651	381	COL151		G	189	651
334	COL198		R	2163	651	382	COL150		R	147	651

Pad #	Pad Name	Signal	Color	X-pos	Y-pos	Pad #	Pad Name	Signal	Color	X-pos	Y-pos
383	COL149	SEG49	B	105	651	431	COL101	SEG33	B	-1911	651
384	COL148		G	63	651	432	COL100		G	-1953	651
385	COL147		R	21	651	433	COL99		R	-1995	651
386	COL146	SEG48	B	-21	651	434	COL98	SEG32	B	-2037	651
387	COL145		G	-63	651	435	COL97		G	-2079	651
388	COL144		R	-105	651	436	COL96		R	-2121	651
389	COL143	SEG47	B	-147	651	437	COL95	SEG31	B	-2163	651
390	COL142		G	-189	651	438	COL94		G	-2205	651
391	COL141		R	-231	651	439	COL93		R	-2247	651
392	COL140	SEG46	B	-273	651	440	COL92	SEG30	B	-2289	651
393	COL139		G	-315	651	441	COL91		G	-2331	651
394	COL138		R	-357	651	442	COL90		R	-2373	651
395	COL137	SEG45	B	-399	651	443	COL89	SEG29	B	-2415	651
396	COL136		G	-441	651	444	COL88		G	-2457	651
397	COL135		R	-483	651	445	COL87		R	-2499	651
398	COL134	SEG44	B	-525	651	446	COL86	SEG28	B	-2541	651
399	COL133		G	-567	651	447	COL85		G	-2583	651
400	COL132		R	-609	651	448	COL84		R	-2625	651
401	COL131	SEG43	B	-651	651	449	COL83	SEG27	B	-2667	651
402	COL130		G	-693	651	450	COL82		G	-2709	651
403	COL129		R	-735	651	451	COL81		R	-2751	651
404	COL128	SEG42	B	-777	651	452	COL80	SEG26	B	-2793	651
405	COL127		G	-819	651	453	COL79		G	-2835	651
406	COL126		R	-861	651	454	COL78		R	-2877	651
407	COL125	SEG41	B	-903	651	455	COL77	SEG25	B	-2919	651
408	COL124		G	-945	651	456	COL76		G	-2961	651
409	COL123		R	-987	651	457	COL75		R	-3003	651
410	COL122	SEG40	B	-1029	651	458	COL74	SEG24	B	-3045	651
411	COL121		G	-1071	651	459	COL73		G	-3087	651
412	COL120		R	-1113	651	460	COL72		R	-3129	651
413	COL119	SEG39	B	-1155	651	461	COL71	SEG23	B	-3171	651
414	COL118		G	-1197	651	462	COL70		G	-3213	651
415	COL117		R	-1239	651	463	COL69		R	-3255	651
416	COL116	SEG38	B	-1281	651	464	COL68	SEG22	B	-3297	651
417	COL115		G	-1323	651	465	COL67		G	-3339	651
418	COL114		R	-1365	651	466	COL66		R	-3381	651
419	COL113	SEG37	B	-1407	651	467	COL65	SEG21	B	-3423	651
420	COL112		G	-1449	651	468	COL64		G	-3465	651
421	COL111		R	-1491	651	469	COL63		R	-3507	651
422	COL110	SEG36	B	-1533	651	470	COL62	SEG20	B	-3549	651
423	COL109		G	-1575	651	471	COL61		G	-3591	651
424	COL108		R	-1617	651	472	COL60		R	-3633	651
425	COL107	SEG35	B	-1659	651	473	COL59	SEG19	B	-3675	651
426	COL106		G	-1701	651	474	COL58		G	-3717	651
427	COL105		R	-1743	651	475	COL57		R	-3759	651
428	COL104	SEG34	B	-1785	651	476	COL56	SEG18	B	-3801	651
429	COL103		G	-1827	651	477	COL55		G	-3843	651
430	COL102		R	-1869	651	478	COL54		R	-3885	651

Pad #	Pad Name	Signal	Color	X-pos	Y-pos	Pad #	Pad Name	Signal	Color	X-pos	Y-pos
479	COL53	SEG17	B	-3927	651	527	COL5	SEG1	B	-5943	651
480	COL52		G	-3969	651	528	COL4		G	-5985	651
481	COL51		R	-4011	651	529	COL3		R	-6027	651
482	COL50	SEG16	B	-4053	651	530	COL2	SEG0	B	-6069	651
483	COL49		G	-4095	651	531	COL1		G	-6111	651
484	COL48		R	-4137	651	532	COL0		R	-6153	651
485	COL47	SEG15	B	-4179	651						
486	COL46		G	-4221	651						
487	COL45		R	-4263	651						
488	COL44	SEG14	B	-4305	651						
489	COL43		G	-4347	651						
490	COL42		R	-4389	651						
491	COL41	SEG13	B	-4431	651						
492	COL40		G	-4473	651						
493	COL39		R	-4515	651						
494	COL38	SEG12	B	-4557	651						
495	COL37		G	-4599	651						
496	COL36		R	-4641	651						
497	COL35	SEG11	B	-4683	651						
498	COL34		G	-4725	651						
499	COL33		R	-4767	651						
500	COL32	SEG10	B	-4809	651						
501	COL31		G	-4851	651						
502	COL30		R	-4893	651						
503	COL29	SEG9	B	-4935	651						
504	COL28		G	-4977	651						
505	COL27		R	-5019	651						
506	COL26	SEG8	B	-5061	651						
507	COL25		G	-5103	651						
508	COL24		R	-5145	651						
509	COL23	SEG7	B	-5187	651						
510	COL22		G	-5229	651						
511	COL21		R	-5271	651						
512	COL20	SEG6	B	-5313	651						
513	COL19		G	-5355	651						
514	COL18		R	-5397	651						
515	COL17	SEG5	B	-5439	651						
516	COL16		G	-5481	651						
517	COL15		R	-5523	651						
518	COL14	SEG4	B	-5565	651						
519	COL13		G	-5607	651						
520	COL12		R	-5649	651						
521	COL11	SEG3	B	-5691	651						
522	COL10		G	-5733	651						
523	COL9		R	-5775	651						
524	COL8	SEG2	B	-5817	651						
525	COL7		G	-5859	651						
526	COL6		R	-5901	651						

Pad #	Signal	X-pos	Y-pos
533	ROW34	-6279	651
534	ROW35	-6321	651
535	ROW36	-6363	651
536	ROW37	-6405	651
537	ROW38	-6447	651
538	ROW39	-6489	651
539	ROW40	-6531	651
540	ROW41	-6573	651
541	ROW42	-6615	651
542	ROW43	-6657	651
543	ROW44	-6699	651
544	ROW45	-6741	651
545	ROW46	-6783	651
546	ROW47	-6825	651
547	ROW48	-6867	651
548	ROW49	-6909	651
549	ROW50	-6951	651
550	ROW51	-6993	651
551	ROW52	-7035	651
552	ROW53	-7077	651
553	ROW54	-7119	651
554	ROW55	-7161	651
555	ROW56	-7203	651
556	ROW57	-7245	651
557	ROW58	-7287	651
558	ROW59	-7329	651
559	ROW60	-7371	651
560	ROW61	-7413	651
561	ROW62	-7455	651
562	ROW63	-7497	651
563	ROW64	-7539	651
564	ROW65	-7581	651
565	ROW66	-7623	651
566	ROW67	-7665	651
567	DUMMY	-7718.5	651

Bump Size

PAD#	X [um]	Y [um]	Pad pitch [um] (Min)
Pad 1-203	56	92	76.3
Pad 204	50	118	53.5
Pad 205 - 566	27	118	42
Pad 567	50	118	53.5

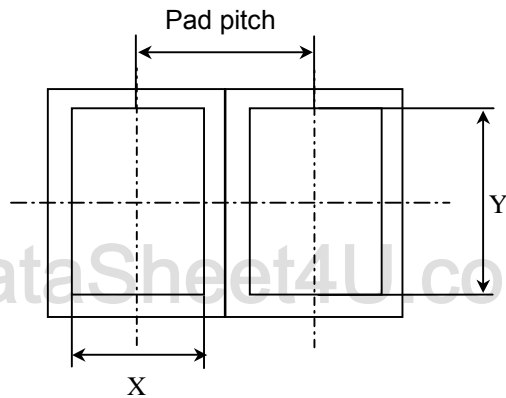

6 PIN DESCRIPTION

6.1 \overline{CS}

This pin is the chip selection input. The chip is enabled for MCU communication only when \overline{CS} is pulled low.

6.2 \overline{RES}

This pin is the reset signal input. Initialization of the chip is started once the reset pin is pulled low. The minimum pulse width for reset sequence is 10us.

6.3 D/\overline{C}

This pin is Data/Command control pin. When the pin is pulled high, the input at D7-D0 is treated as display data. When the pin is pulled low, the input at D7-D0 will be transferred to the command register.

6.4 R/\overline{W} (\overline{WR})

This pin is MCU interface input. When 6800 interface mode is selected, this pin will be used as Read/Write R/\overline{W} selection input. Read mode will be carried out when this pin is pulled high and write mode when this pin is pulled low.

When 8080 interface mode is selected, this pin is the Write (\overline{WR}) control signal input. Data write operation is initiated when this pin is pulled low and the chip is selected.

6.5 $E(\overline{RD})$

This pin is MCU interface input. When 6800 interface mode is selected, this pin will be used as the Enable (E) signal. Read/ write operation is initiated when this pin is pulled high and the chip is selected.

When 8080 interface mode is selected, this pin is the Read (\overline{RD}) control signal input. Data read operation is initiated when this pin is pulled low and the chip is selected.

6.6 PS0 – PS1

These pins are the bus interface mode selection input. Different bus interface can be selected changing the setting of these pins.

PS1	PS0	MPU Interface
L	H	8-bit 8080 parallel interface
H	H	8-bit 6800 parallel interface
H	L	3-lines serial peripheral interface (SPI) – 9 bits SPI
L	L	4-lines serial peripheral interface (SPI)

Note1: For serial applications, D0 – D5, R/\overline{W} (\overline{WR}), $E(\overline{RD})$ are recommended to connect V_{DD} .

Note2: Read back operation is only available in parallel mode

6.7 D7-D0

These pins are the 8-bit bi-directional data bus in parallel interface mode. D7 is the MSB while D0 is the LSB. When serial mode selected, D7 is the serial data input SDA and D6 is the serial clock input SCK.

6.8 V_{LREF}

This pin is the ground of operation amplifier V_{L4} and V_{L5} . It must connect to V_{SS} .

6.9 V_{HREF}

This pin is the power supply pin of the operation amplifier V_{L3} . It must connect to V_{OUT}

6.10 V_{CIX2}

This pin is internal reference pin. It must connect to V_{CI}

6.11 V_{DD}

This pin is the system power supply pin of the logic block.

6.12 V_{DDIO}

This pin is the system power supply pin of I/O buffer. Please refer to Figure on page 69 for connection example.

6.13 V_{CI}

This pin is the reference voltage input for internal DC-DC converter. The DC-DC converter output is equals to the multiple factor (3X, 4X, 5X or 6X) times of V_{CI} with respect to V_{SS}. The maximum output voltage will limit by the max. V_{OUT} characteristic.

Note: Voltage at this input pin must be larger than or equal to V_{DD}. (V_{CI} ≥ V_{DD})

6.14 V_{SS}

This pin is the ground of logic.

6.15 RV_{SS}

This pin is the ground of Vref.

6.16 CV_{SS}

This pin is the ground of analog.

6.17 V_{OUT}

This is the most positive voltage supply pin of the chip. It can be supplied externally or generated by the internal DC-DC converter. If the internal DC-DC converter generates the voltage level at V_{OUT}, the voltage level is used for internal referencing only. The voltage level at V_{OUT} pin is not used for driving external circuitry.

6.18 V_{L5}, V_{L4}, V_{L3} and V_{L2}

LCD driving voltages. They can be supplied externally or generated by the internal bias divider. They have the following relationship:

$$V_{OUT} > V_{L5} > V_{L4} > V_{L3} > V_{L2} > V_{SS}$$

	1 : a bias
V _{L5}	(a-1)/a * V _{out}
V _{L4}	(a-2)/a * V _{out}
V _{L3}	2/a * V _{out}
V _{L2}	1/a * V _{out}

Table 3 - V_{OUT} > V_{L5} > V_{L4} > V_{L3} > V_{L2} > V_{SS} Relationship

6.19 ROW0 – ROW67

These pins provide the driving signals, COMMON, to the LCD panel.

6.20 COL0 – COL293

These pins provide the LCD driving signals, SEGMENT, to the LCD panel. The Red, Green, Blue colors signal are sent out from the SEGMENT output at the same time. The output voltage level of these pins is V_{DD} during sleep mode or standby mode.

6.21 CL

This pin is the system clock I/O. This pin is the external clock input for the device, which is enabled by using extended command. It should be left open under normal operation. The internal oscillator will be used after power on reset.

6.22 M

This pin is used for cascade purpose only. It should be left open under normal operation.

6.23 SYN

This pin is used for cascade purpose only. It should be left open under normal operation.

6.24 BUSY

This pin will be high during RAM buffer read/write operation and during graphic commands executing. System programmer should read this pin (low is ready, high is busy) before sending next RAM buffer related command (e.g. RAM write – 5CH; RAM read – 5DH OR any graphic commands)

6.25 TEST1 ~ TEST18

These pins are used for internal only and should be left open, any connection is not allowed.

6.26 Dummy

This is a floating dummy pad without any internal circuitry connection.

www.DataSheet4U.com

7 FUNCTIONAL BLOCK DESCRIPTIONS

7.1 Microprocessor Interface Logic

The Microprocessor Interface unit consists of three functional blocks for driving the 6800-series parallel interface, 8080-series parallel interface, 3-lines serial peripheral interface and 4-lines serial peripheral interface. The selection of different interface is done by PS0 to PS1 pins. Please refer to the pin descriptions on page 14.

a) MPU Parallel 6800-series Interface

The parallel Interface consists of 8 bi-directional data pins (D7 – D0), $\overline{R/W}$, $\overline{D/C}$, E, \overline{CS} . $\overline{R/W}$ (\overline{WR}) input high indicates a read operation from the Graphical Display Data RAM (GDDRAM) or the status register. $\overline{R/W}$ input low indicates a write operation to Display Data RAM or Internal Command Registers depending on the status of $\overline{D/C}$ input. The E input serves as data latch signal (clock) when high provided that \overline{CS} is low. Please refer to Figure 19 & Figure 20 on page 57 to 58 for Parallel Interface Timing Diagram of 6800-series microprocessors. In order to match the operating frequency of the GDDRAM with that of the MCU, some pipeline processing is internally performed which requires the insertion of a dummy read before the first actual display data read. This is shown in the following diagram.

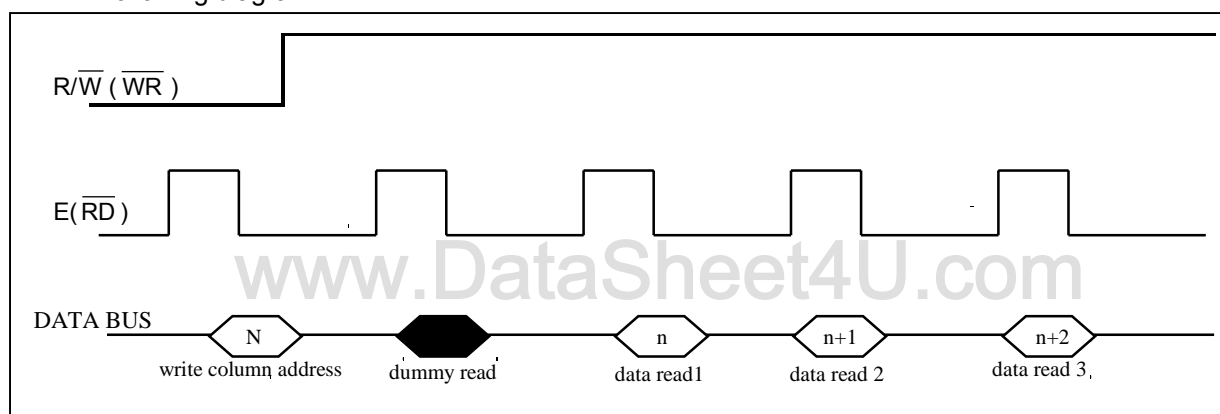

Figure 3 - Display Data

b) MPU Parallel 8080-series Interface

The parallel interface consists of 8 bi-directional data pins D7 – D0, \overline{RD} , \overline{WR} , $\overline{D/C}$, \overline{CS} . \overline{RD} input serves as data read latch signal (clock) when low provided that \overline{CS} is low. Whether reading the display data from GDDRAM or reading the status from the status register is controlled by $\overline{D/C}$. \overline{WR} input serves as data write latch signal (clock) when low provided that \overline{CS} is low. Whether writing the display data to the GDDRAM or writing the command to the command register is controlled by $\overline{D/C}$. A dummy read is also required before the first actual display data read for 8080-series interface.

c) MPU 4-lines Serial Peripheral Interface

The 4-lines serial peripheral Interface consists of serial clock SCK, serial data SDA, $\overline{D/C}$, \overline{CS} . SDA is shifted into 8-bit shift register on every rising edge of SCK in the order of data bit 7, data bit 6 data bit 0. $\overline{D/C}$ is sampled on every eighth clock to determine whether the data byte in the shift register is written to the Display Data RAM or command register at the same clock. Please refer to Figure 23 on page 61 for serial interface timing.

d) MPU 3-lines Serial Peripheral Interface

The operation is similar to 4-lines serial peripheral interface while D/\bar{C} is not used. There are altogether 9-bits will be shifted into the shift register on every ninth clock in sequence: D/\bar{C} bit, D7 to D0 bit. The D/\bar{C} bit (first bit of the sequential data) will determine the following data byte in the shift register is written to the Display Data RAM (D/\bar{C} bit = 1) or the command register (D/\bar{C} bit = 0).

	6800 – series Parallel Interface	8080 – series Parallel Interface	3-lines or 4-lines Serial peripheral Interface
Data Read	8-bits	8-bits	No
Data Write	8-bits	8-bits	8-bits
Command Read	Status only	Status only	No
Command Write	Yes	Yes	Yes

Table 4 - Data bus selection modes

www.DataSheet4U.com

7.2 Reset Circuit

This block is integrated into the Microprocessor Interface Logic which includes Power On Reset circuitry and the hardware reset pin, RES. Both of these having the same reset function. Once the $\overline{\text{RES}}$ pin receives a negative reset pulse, all internal circuitry will start to initialize. The minimum pulse width for completing the reset sequence is 10us. The status of the chip after reset is given by:

When $\overline{\text{RES}}$ input is low, the chip is initialized to the following:

- | | |
|--------------------------------------------|----------------------------|
| 1. Display ON/OFF: | Display is OFF |
| 2. Normal/Inverse Display: | Normal Display |
| 3. COM Scan Direction: | COM0 -> COM67 |
| 4. Internal Oscillator: | Disable |
| 5. Reference Voltage Generation Circuit: | Disable |
| 6. Voltage regulator and Voltage Follower: | Disable |
| 7. Booster level: | 6X |
| 8. Bias ratio: | 1/7(68 Mux) |
| 9. Multiplex ratio: | 68 Mux |
| 10. Contrast Level: | 32 |
| 11. Internal regulator gain: | 2.84 |
| 12. Average temperature gradient: | -0.2%/°C |
| 13. Partial display mode: | Disable |
| Start COM address: | 0 |
| End COM address: | 0 |
| 14. Area Scroll set | |
| Top block address: | 0 |
| Bottom block address: | 0 |
| Number of specified block: | 0 |
| Area scroll mode: | Whole screen scroll mode |
| 15. Scroll start set | |
| Start block address: | 0 |
| 16. Data Scan Direction | |
| Normal/inverse display of page address: | Normal |
| Normal/inverse display of column address: | Normal |
| Address-scan direction: | Column direction |
| RGB arrangement: | RGB |
| Gray-scale setup: | 8 gray-scale |
| 17. Start Page Address set: | 0 |
| 18. End Page Address set: | 0 |
| 19. Start Column address set: | 0 |
| 20. End Column address set: | 0 |
| 21. Select PWM/FRC | 2-bit PWM + 2 bit FRC mode |

7.3 Command Decoder

This module determines whether the input data is interpreted as data or command. Data is directed to this module based upon the input of the D/\bar{C} pin. If D/\bar{C} pin is high, data is written to Graphic Display data RAM (GDDRAM). If it is low, the input at D7 – D0 is interpreted as a Command and it will be decoded. The decoded command will be written to the corresponding command register.

7.4 Graphic Display Data RAM (GDDRAM)

The GDDRAM is a bit mapped static RAM holding the bit pattern to be displayed. The size of the RAM is $294 (98 \text{ RGB}) \times 68 \times 4 = 79,968$ bits. Figure 4 on page 21 is a description of the GDDRAM address map. For mechanical flexibility, re-mapping on both Segment and Common outputs can be selected by software. Please refer to the command “Data Output/Scan direction” in Table 5 on page 24 for detail description.

Four pages of display data form a RAM address block and stored in the GDDRAM. Each block will form the fundamental units of scrolling addresses. Various types of area scrolling can be performed by software program according to the command “Set area Scroll” and “Set Scroll Start” in Table 11 on page 39.

In order to ease the access of the red, green and blue color data; the 8-bits color data (Red: 3 bits, Green: 3 bits, Blue: 2 bits) is converted to 4-bits data (P10, P11, P12, P13). The 4-bits data are stored into the GDDRAM such that the data are located in the appropriate RAM locations according to the gray scale settings. Please refer to the description section of the command “Set Data Output/Scan Direction” on page 24.

www.DataSheet4U.com

7.5 LCD Driving Voltage Generator and Regulator

This module generates the LCD voltage needed for display output. It takes a single supply input and generates necessary bias voltages. It consists of:

1. 3X, 4X, 5X and 6X DC-DC voltage converter
2. Bias Divider - If the output op-amp buffer option in Set Power Control Register command is enabled, this circuit block will divide the regulator output (V_{OUT}) to give the LCD driving levels ($V_{L2} - V_{L5}$). The divider does not require external capacitors to reduce the external hardware and pin counts, power configuration of op-amp is shown on Figure 5 on page 22. Contrast Control -Software control of 64 voltage levels of LCD voltage.
3. Bias Ratio Selection circuitry – Software control of 1/4 to 1/8 bias ratio to match the characteristic of LCD panel.
4. Self adjust temperature compensation circuitry - Provide 4 different compensation grade selections to satisfy the various liquid crystal temperature grades. The grading can be selected by software control. Defaulted temperature coefficient (TC) value is $-0.2\%/^{\circ}\text{C}$.

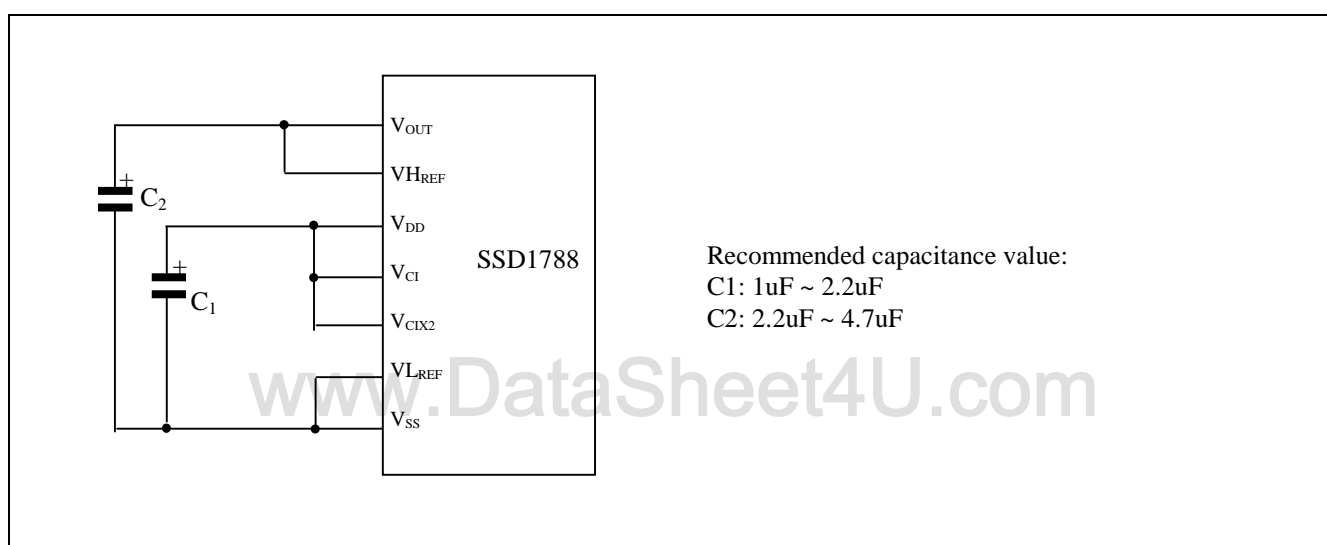

Figure 5 - SSD1788 Hardware Configurations

7.6 Oscillator Circuit

This module is an On-Chip low power RC oscillator circuitry (Figure 6). The oscillator generates the clock for the DC-DC voltage converter. This clock is also used in the Display Timing Generator.

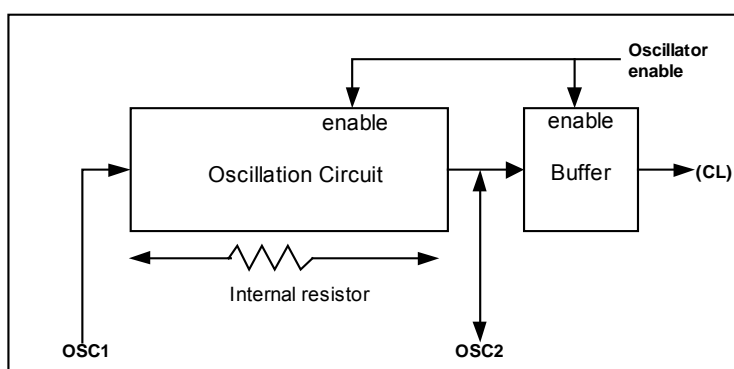

Figure 6 - Oscillator structural block diagram

7.7 Display Data Latch

This block is a series of latches carrying the display signal information. These latches hold the data, which will be fed to the HV Buffer Cell and Level Selector to output the required voltage level.

7.8 HV Buffer Cell (Level Shifter)

This block is embedded in the Segment/Common Driver Circuits. HV Buffer Cell works as a level shifter, which translates the low voltage output signal to the required driving voltage. The output is shifted out with reference to the internal FRM clock, which comes from the Display Timing Generator. The voltage levels are given by the level selector, which is synchronized with the internal M signal.

7.9 Level Selector

This block is embedded in the Segment/Common Driver circuits. Level Selector is a control of the display synchronization. Display voltage levels can be separated into two sets and used with different cycles. Synchronization is important since it selects the required LCD voltage level to the HV Buffer Cell, which in turn outputs the COM or SEG LCD waveform.

www.DataSheet4U.com

8 COMMAND TABLE

Table 5 - Command Table

D/C	Hex	D7	D6	D5	D4	D3	D2	D1	D0	Command	Description
0 1 1	15	0 X ₇ Y ₇	0 X ₆ Y ₆	0 X ₅ Y ₅	1 X ₄ Y ₄	0 X ₃ Y ₃	1 X ₂ Y ₂	0 X ₁ Y ₁	1 X ₀ Y ₀	Set Column Address	Set the start column address by X ₇ X ₆ X ₅ X ₄ X ₃ X ₂ X ₁ X ₀ Set the end column address by Y ₇ Y ₆ Y ₅ Y ₄ Y ₃ Y ₂ Y ₁ Y ₀ Column address = 00000000b (POR) In 8-levels gray scale mode, column address is in a range of 0~97. In 16-level gray scale mode, column address is in a range of 0~48.
0 1 1	75	0 X ₇ Y ₇	1 X ₆ Y ₆	1 X ₅ Y ₅	1 X ₄ Y ₄	0 X ₃ Y ₃	1 X ₂ Y ₂	0 X ₁ Y ₁	1 X ₀ Y ₀	Set Page Address	Set the start page address by X ₇ X ₆ X ₅ X ₄ X ₃ X ₂ X ₁ X ₀ Set the end page address by Y ₇ Y ₆ Y ₅ Y ₄ Y ₃ Y ₂ Y ₁ Y ₀ . Page address = 00000000b (POR)
0 1	BB	1 *	0 *	1 *	1 *	1 *	0 X ₂	1 X ₁	1 X ₀	Set COM Output Scan Direction	X ₂ X ₁ X ₀ ROW0...ROW33 ROW34...ROW67 0 0 0 COM0 ->COM33 COM34 ->COM67 (POR) 0 0 1 COM0 ->COM33 COM67 <-COM34 0 1 0 COM33<-COM0 COM34 ->COM67 0 1 1 COM33<-COM0 COM67 <-COM34
0 1 1 1	BC	1 * * *	0 * * *	1 * * *	1 * * *	1 * * *	1 P ₁₂ P ₂₂ P ₃₂	0 P ₁₁ P ₂₁ P ₃₁	0 P ₁₀ P ₂₀ P ₃₀	Set Data Output Scan Direction	a) Normal or Reverse page/column/scan directions P ₁₀ = 0: set page address to normal display (POR) P ₁₀ = 1: set page address to inverse display P ₁₁ = 0: set column address to normal rotation (POR) P ₁₁ = 1: set column address to inverse rotation P ₁₂ = 0: set scan direction to column scan (POR) P ₁₂ = 1: set scan direction to page scan Please refer to the Figure 7 & Figure 8 on page 35 & 36 respectively for detail description of column/page scan direction modes b) RGB color arrangement P ₂₂ , P ₂₁ , P ₂₀ : The control bits are used for setting the (RGB) color arrangement of segment output. , 000 is the POR value. Please refer to the Figure 10 on page 37 for detail mapping of the segment output. c) Gray-scale selection P ₃₂ P ₃₁ P ₃₀ Gray-scale modes 0 0 1 8-levels gray scale mode (POR) 0 1 0 16-levels gray scale mode (Type A) Please refer to the Table 9 on page 37 to Table 10 on page 37 for detail description of different gray-scale selection modes.

D/C	Hex	D7	D6	D5	D4	D3	D2	D1	D0	Command	Description
0 1 1 1 1 1 1 1 1	CE	1 * * * * * * * *	1 * * * * * * * *	0 * * * * * * * *	0 * * * * * * * *	1 X ₃₁ X ₃₂ : : X ₃₈ X ₃₉ : : X ₃₁₆ X ₃₁₇ : : X ₃₂₀	1 X ₂₁ X ₂₂ : : X ₂₈ X ₂₉ : : X ₂₁₆ X ₂₁₇ : : X ₂₂₀	1 X ₁₁ X ₁₂ : : X ₁₈ X ₁₉ : : X ₁₁₆ X ₁₁₇ : : X ₁₂₀	0 X ₀₁ X ₀₂ : : X ₀₈ X ₀₉ : : X ₀₁₆ X ₀₁₇ : : X ₀₂₀	Set Color Look Up Table (Gray-scale selection: P ₃₂ P ₃₂ P ₃₀ = 001)	N DB3 DB2 DB1DB0 color position 1 X _{3N} X _{2N} X _{1N} X _{0N} Intermediate red tone 000 2 X _{3N} X _{2N} X _{1N} X _{0N} Intermediate red tone 001 : : : 8 X _{3N} X _{2N} X _{1N} X _{0N} Intermediate red tone 111 9 X _{3N} X _{2N} X _{1N} X _{0N} Intermediate green tone 000 : : : 16 X _{3N} X _{2N} X _{1N} X _{0N} Intermediate green tone 111 17 X _{3N} X _{2N} X _{1N} X _{0N} Intermediate blue tone 00 : : : 20 X _{3N} X _{2N} X _{1N} X _{0N} Intermediate blue tone 11
0 1 1 1	CA	1 0 * 0	1 0 * 0	0 0 * 0	0 0 Y ₄ 0	1 0 Y ₃ 0	0 0 Y ₂ 0	1 0 Y ₁ 0	0 0 Y ₀ 0	Set Display Control	Driver duty selection Select driver duty from 1/8 to 1/68. As Y ₄ Y ₃ Y ₂ Y ₁ Y ₀ is increased from 00001b to 10000b, the number of display lines, N is increased at the same rating. To specify the Y ₄ Y ₃ Y ₂ Y ₁ Y ₀ . $Y_4 \sim Y_0 = \frac{N}{4} - 1$ A dummy byte should be sent before the command byte Y ₄ to Y ₀ . After the command byte is sent, an additional dummy byte should be sent to the device in order to finish the whole command.
0 1 1 1 1	AA	1 * * * *	0 * * * *	1 * * * *	0 X ₄ Y ₄ Z ₄ *	1 X ₃ Y ₃ Z ₃ *	0 X ₂ Y ₂ Z ₂ *	1 X ₁ Y ₁ Z ₁ P ₄₁	0 X ₀ Y ₀ Z ₀ P ₄₀	Set Area Scroll	a) Top Block Address X ₄ X ₃ X ₂ X ₁ X ₀ is used to specify the block address (1 block = 4 lines) at the top of the scrolling area. Top block address = 00000b (POR) b) Bottom Block Address Y ₄ Y ₃ Y ₂ Y ₁ Y ₀ is used to specify the block address (1 block = 4 lines) at the bottom of the scrolling area. Bottom block address = 00000b (POR) c) Number of specified Blocks The number of specified blocks = Number of (Top fixed area + Scroll area) blocks -1. If bottom scroll or whole screen scroll mode is chosen, the number of specified blocks is set to Z ₄ ~Z ₀ Number of specified blocks = 00000b (POR) d) Area Scroll Mode There are four types of area scroll. P ₄₁ P ₄₀ Types of Area Scroll 0 0 Center Screen Scroll 0 1 Top Screen Scroll 1 0 Bottom Screen Scroll 1 1 Whole Screen Scroll Type of area scroll = Whole Screen Scroll (POR)
0 1	AB	1 *	0 *	1 *	0 X ₄	1 X ₃	0 X ₂	1 X ₁	1 X ₀	Set Scroll Start	X ₄ X ₃ X ₂ X ₁ X ₀ specify the start block address (1 block = 4 lines) of area scrolling. Start block address = 00000b (POR)

D/C	Hex	D7	D6	D5	D4	D3	D2	D1	D0	Command	Description
0 1	20	0 *	0 *	1 *	0 *	0 X ₃	0 X ₂	0 X ₁	0 X ₀	Set Power Control Register	<p>X₀=0: turns off the reference voltage generator (POR) X₀=1: turns on the reference voltage generator X₁=0: turns off the internal regulator and voltage follower (POR) X₁=1: turns on the internal regulator and voltage follower Select booster level</p> <p>X₃ X₂ Boost level 0 0 3X 0 1 4X 1 0 5X 1 1 6X (POR)</p>
0 1 1	81	1 * *	0 * *	0 X ₅ *	0 X ₄ *	0 X ₃ *	0 X ₂ Y ₂	0 X ₁ Y ₁	1 X ₀ Y ₀	Set Contrast Level & Internal Regulator Resistor Ratio	<p>a) Select contrast level from 64 contrast steps Contrast increases (V₂ decreases) as X₅X₄X₃X₂X₁X₀ is increased from 000000b to 111111b. X₅X₄X₃X₂X₁X₀ = 000000b (POR)</p> <p>b) The internal regulator gain (1+R₂/R₁) V_{OUT} increases as Y₂Y₁Y₀ is increased from 000b to 111b. The factor, 1+R₂/R₁, is given by: Y₂Y₁Y₀ = 000: 2.84 (POR) Y₂Y₁Y₀ = 001: 3.71 Y₂Y₁Y₀ = 010: 4.57 Y₂Y₁Y₀ = 011: 5.44 Y₂Y₁Y₀ = 100: 6.30 Y₂Y₁Y₀ = 101: 7.16 Y₂Y₁Y₀ = 110: 8.03 Y₂Y₁Y₀ = 111: 8.89</p>
0	D6 - D7	1	1	0	1	0	1	1	X ₀	Increment / Decrement of the contrast set	<p>X₀=0: The contrast set of voltage regulator is incremented by 1 X₀=1: The contrast set of voltage regulator is decremented by 1</p>
0	A6 - A7	1	0	1	0	0	1	1	X ₀	Set Normal/Inverse Display	<p>X₀=0: normal display (POR) X₀=1: inverse display</p>
0 1 1	A8	1 * *	0 X ₆ Y ₆	1 X ₅ Y ₅	0 X ₄ Y ₄	1 X ₃ Y ₃	0 X ₂ Y ₂	0 X ₁ Y ₁	0 X ₀ Y ₀	Enter partial Display	<p>X₆X₅X₄X₃X₂X₁X₀: Start COM Address = 000000b (POR) Y₆Y₅Y₄Y₃Y₂Y₁Y₀: End COM Address = 000000b (POR)</p>
0	A9	1	0	1	0	1	0	0	1	Exit partial Display	Exit the "partial display mode" by executing the command 10101001b (POR)
0	AE - AF	1	0	1	0	1	1	1	X ₀	Set Display On/Off	<p>X₀=0: turns off LCD panel (POR) X₀=1: turns on LCD panel</p>
0	94 - 95	1	0	0	1	0	1	0	X ₀	Enter/Exit sleep mode	<p>X₀=0: exit the sleep mode. X₀=1: enter sleep mode. (POR)</p>
0	D1 - D3	1	1	0	1	0	0	X ₁	X ₀	Enable/disable internal oscillator	<p>X₁ X₀ Internal oscillator status 0 1 ON 1 0 OFF (POR)</p>

D/C	Hex	D7	D6	D5	D4	D3	D2	D1	D0	Command	Description
0 1	82	1 *	0 *	0 *	0 *	0 *	0 *	1 X ₁	0 X ₀	Set Temperature compensation coefficient	Average temperature gradients X ₁ X ₀ Average Temperature Gradient [%/oC] 0 0 -0.10 0 1 -0.15 1 0 -0.20(POR) 1 1 -0.25
0	25	0	0	1	0	0	1	0	1	NOP	Command result in No Operation The command should be issued after the execution of the Status Read command
0 1	5C	0 Y ₇₁	1 Y ₆₁	0 Y ₅₁	1 Y ₄₁	1 Y ₃₁	1 Y ₂₁	0 Y ₁₁	0 Y ₀₁	Write display data	Enter the "write display data mode " by executing the command 01011100b. The following byte is used to specify the data byte to be written to the GDDRAM directly. The bit should be stated at logic "1" during the display data is written to the GDDRAM.

www.DataSheet4U.com

Graphic command table

D/C	Hex	D7	D6	D5	D4	D3	D2	D1	D0	Command	Description
0 1 1 1 1 1 1	83	1 A ₇ B ₇ C ₇ D ₇ R ₃ *	0 A ₆ B ₆ C ₆ D ₆ R ₂ *	0 A ₅ B ₅ C ₅ D ₅ R ₁ *	0 A ₄ B ₄ C ₄ D ₄ R ₀ *	0 A ₃ B ₃ C ₃ D ₃ G ₃ B ₃	0 A ₂ B ₂ C ₂ D ₂ G ₂ B ₂	1 A ₁ B ₁ C ₁ D ₁ G ₁ B ₁	1 A ₀ B ₀ C ₀ D ₀ G ₀ B ₀	Draw Line	Enter the "Draw line mode" by executing the command 1000011. The following four bytes (A ₀ to A ₇ , B ₀ to B ₇ , C ₀ to C ₇ , D ₀ to D ₇) are used to specify the start coordinates of X address, start coordinates of Y address, end coordinates of X address and the end coordinates of Y address. The remaining two bytes are used to specify the color. <i>Remarks: A ≤ 97; B ≤ 67; C ≤ 97; D ≤ 67</i>
0 1	92	1 *	0 *	0 *	1 *	0 *	0 *	1 *	0 A ₀	Fill Enable/Disable	Enter the "Fill Enable/Disable mode" by executing the command 10010010. A ₀ =0: Filled color option is disabled (POR) A ₀ =1: Filled color option is enabled
0 1 1 1 1 1 1 1	84	1 A ₇ B ₇ C ₇ D ₇ R ₃ * R ₃ *	0 A ₆ B ₆ C ₆ D ₆ R ₂ * R ₂ *	0 A ₅ B ₅ C ₅ D ₅ R ₁ * R ₁ *	0 A ₄ B ₄ C ₄ D ₄ R ₀ * R ₀ *	0 A ₃ B ₃ C ₃ D ₃ G ₃ B ₃	1 A ₂ B ₂ C ₂ D ₂ G ₂ B ₂	0 A ₁ B ₁ C ₁ D ₁ G ₁ B ₁	0 A ₀ B ₀ C ₀ D ₀ G ₀ B ₀	Draw rectangle	Enter the "Draw rectangle mode" by executing the command 10000100. The following four bytes (A ₀ to A ₇ , B ₀ to B ₇ , C ₀ to C ₇ , D ₀ to D ₇) are used to specify the start coordinates of X address, start coordinates of Y address, end coordinates of X address and the end coordinates of Y address. The next two bytes are used to specify the color. The last two bytes are used to specify the fill color. <i>Remarks: A ≤ C; B ≤ D; C ≤ 97; D ≤ 67</i>
0 1 1 1 1 1 1	8A	1 A ₇ B ₇ C ₇ D ₇ E ₇ F ₇	0 A ₆ B ₆ C ₆ D ₆ E ₆ F ₆	0 A ₅ B ₅ C ₅ D ₅ E ₅ F ₅	0 A ₄ B ₄ C ₄ D ₄ E ₄ F ₄	1 A ₃ B ₃ C ₃ D ₃ E ₃ F ₃	0 A ₂ B ₂ C ₂ D ₂ E ₂ F ₂	1 A ₁ B ₁ C ₁ D ₁ E ₁ F ₁	0 A ₀ B ₀ C ₀ D ₀ E ₀ F ₀	Copy	Enter the "Copy mode" by executing the command. The following four bytes (A ₀ to A ₇ , B ₀ to B ₇ , C ₀ to C ₇ , D ₀ to D ₇) are used to specify the start coordinates of X address, start coordinates of Y address, end coordinates of X address and the end coordinates of Y address. The remaining two bytes (E ₀ to E ₇ , F ₀ to F ₇) are used to specify the new location of X coordinates and Y coordinates. <i>Remarks: A ≤ C; B ≤ D; C ≤ 97; D ≤ 67</i>
0 1 1 1 1	8C	1 A ₇ B ₇ C ₇ D ₇	0 A ₆ B ₆ C ₆ D ₆	0 A ₅ B ₅ C ₅ D ₅	0 A ₄ B ₄ C ₄ D ₄	1 A ₃ B ₃ C ₃ D ₃	1 A ₂ B ₂ C ₂ D ₂	0 A ₁ B ₁ C ₁ D ₁	0 A ₀ B ₀ C ₀ D ₀	Dim Window	Enter the "Dim Window mode" by executing the command 10001100. The following four bytes (A ₀ to A ₇ , B ₀ to B ₇ , C ₀ to C ₇ , D ₀ to D ₇) are used to specify the start coordinates of X address, start coordinates of Y address, end coordinates of X address and the end coordinates of Y address. The selected window area will be dimmed by 75% white. <i>Remarks: A ≤ C; B ≤ D; C ≤ 97; D ≤ 67</i>
0 1 1 1 1	8E	1 A ₇ B ₇ C ₇ D ₇	0 A ₆ B ₆ C ₆ D ₆	0 A ₅ B ₅ C ₅ D ₅	0 A ₄ B ₄ C ₄ D ₄	1 A ₃ B ₃ C ₃ D ₃	1 A ₂ B ₂ C ₂ D ₂	1 A ₁ B ₁ C ₁ D ₁	0 A ₀ B ₀ C ₀ D ₀	Clear Window	Enter the "Clear Window mode" by executing the command 10001110. The following four bytes (A ₀ to A ₇ , B ₀ to B ₇ , C ₀ to C ₇ , D ₀ to D ₇) are used to specify the start coordinates of X address, start coordinates of Y address, end coordinates of X address and the end coordinates of Y address. All pixels contrast will be set to 0. <i>Remarks: A ≤ C; B ≤ D; C ≤ 97; D ≤ 67</i>

Remarks: After executed the graphic command, waiting time is required for update GDDRAM content. (When V_{DD}=1.8~2.6V, waiting time = 250ns/pixel; When V_{DD}=2.6~3.6V, waiting time = 125ns/pixel)

Extended command table

D/C	Hex	D7	D6	D5	D4	D3	D2	D1	D0	Command	Description
0 1	FB	1 *	1 *	1 *	1 *	1 0	0 B ₂	1 B ₁	1 B ₀	Set biasing ratio	<p>Allow user to set bias from 1/ 4 to 1/8</p> <p>B₂B₁B₀ Bias ratio</p> <p>0 0 0 1/4 bias</p> <p>0 0 1 1/5 bias</p> <p>0 1 0 1/6 bias</p> <p>0 1 1 1/7 bias (POR)</p> <p>1 0 0 1/8 bias</p> <p>1 0 1 Reserved</p> <p>1 1 X Reserved</p>
0 1 1	F2	1 0 0	1 0 0	1 0 C ₀	1 0 N ₄	0 F ₃ N ₃	0 F ₂ N ₂	1 F ₁ N ₁	0 F ₀ N ₀	Set Frame frequency and N-line Inversion	<p>This command uses to change the frame frequency; set the N-line inversion and N-line inversion mode</p> <p>F₃F₂F₁F₀</p> <p>1 1 1 1 : 111Hz</p> <p>1 1 1 0 : 103.5Hz</p> <p>1 1 0 1 : 98Hz</p> <p>1 1 0 0 : 93Hz</p> <p>1 0 1 1 : 89 Hz</p> <p>1 0 1 0 : 85 Hz</p> <p>1 0 0 1 : 81.5 Hz</p> <p>1 0 0 0 : 78 Hz (POR)</p> <p>0 1 1 1 : 76.5 Hz</p> <p>0 1 1 0 : 73.5 Hz</p> <p>0 1 0 1 : 71 Hz</p> <p>0 1 0 0 : 68 Hz</p> <p>0 0 1 1 : 66.5 Hz</p> <p>0 0 1 0 : 64.5 Hz</p> <p>0 0 0 1 : 62.5 Hz</p> <p>0 0 0 0 : 60.5 Hz</p> <p>C₀ = 0 : The counter reset per N-line and each frame C₀ = 1 : The counter reset per N-line only</p> <p>The second byte data sets the n-line inversion register from 2 to 32 lines to reduce display crosstalk. Register values from 00001b to 11111b are mapped to 2 lines to 32 lines respectively. Value 00000b disables the N-line inversion. 00110 is the POR value.</p> <p>To avoid a fix polarity at some lines, it should be noted that the total number of mux should NOT be a multiple of the lines of inversion (n).</p>
0 1 1 1	F7	1 0 0 *	1 0 0 *	1 1 1 *	1 0 1 *	0 1 1 0	1 0 1 1	1 0 X ₁ 0	1 0 X ₀ 1	Select PWM/FRC	<p>4 bits PWM/FRC or 2 bits PWM + 2 bits FRC selection</p> <p>X₁X₀</p> <p>0 0 : 4 bits PWM</p> <p>0 1 : 4 bits FRC</p> <p>1 0 : 2 bits PWM + 2 bits FRC (POR)</p> <p>1 1 : Reserved</p>

D/C	Hex	D7	D6	D5	D4	D3	D2	D1	D0	Command	Description
0	F6	1	1	1	1	0	1	1	0	OTP setting	This command set the offset value of contrast $X_3X_2X_1X_0$ 0 0 0 0 : original contrast (POR) 0 0 0 1 : original contrast + 1 step 0 0 1 0 : original contrast + 2 steps 0 0 1 1 : original contrast + 3 steps 0 1 0 0 : original contrast + 4 steps 0 1 0 1 : original contrast + 5 steps 0 1 1 0 : original contrast + 6 steps 0 1 1 1 : original contrast + 7 steps 1 0 0 0 : original contrast - 8 steps 1 0 0 1 : original contrast - 7 steps 1 0 1 0 : original contrast - 6 steps 1 0 1 1 : original contrast - 5 steps 1 1 0 0 : original contrast - 4 steps 1 1 0 1 : original contrast - 3 steps 1 1 1 0 : original contrast - 2 steps 1 1 1 1 : original contrast - 1 step $Y_0 = 0$: Disable the OTP setting you have set $Y_0 = 1$: Enable the OTP setting you have set (POR)
1		0	0	0	1	X_3	X_2	X_1	X_0		
1		0	0	0	0	Y_0	0	1	0		
0	F8	1	1	1	1	1	0	0	0	OTP programming	This command start to program LCD driver with OTP offset value. Each bit can be programmed to 1 once. Detail of OTP programming procedure on page 47

www.DataSheet4U.com

Table 6 - Read Command Table

D/C	Hex	D7	D6	D5	D4	D3	D2	D1	D0	Command	Description
0 1 1	5D	0 0 Y ₇₁	1 0 Y ₆₁	0 0 Y ₅₁	1 0 Y ₄₁	1 0 Y ₃₁	1 0 Y ₂₁	0 0 Y ₁₁	1 0 Y ₀₁	Read display data	Enter the "read display data mode" by executing the command 01011100b. The next byte is a dummy data. The GDDRAM data will be read from the second byte. The GDDRAM column address pointer will be increased by one automatically after each data read (8-levels gray scale mode) OR after each 3-bytes data read. (16-levels gray scale mode). <i>Remarks: $R\overline{W} = 1$ when D7 to D0 is read</i>
0 0	5D	0 D ₇	1 D ₆	0 D ₅	1 D ₄	1 D ₃	1 D ₂	0 D ₁	1 D ₀	Status Register Read	D ₇ D ₆ = 00: Center Screen Scroll Mode D ₇ D ₆ = 01: Top Screen Scroll Mode D ₇ D ₆ = 10: Bottom Screen Scroll Mode D ₇ D ₆ = 11: Whole Screen Scroll Mode D ₄ = 0: Scan Direction is column direction D ₄ = 1: Scan Direction is page direction D ₃ = 0: Display is OFF D ₃ = 1: Display is ON D ₂ = 0: Sleep Mode is disabled D ₂ = 1: Sleep Mode is enabled D ₁ = 0: Display is Inverse D ₁ = 1: Display is Normal D ₀ = 0: Partial display is disabled D ₀ = 1: Partial display is enabled <i>Remarks: $R\overline{W} = 1$ when D7 to D0 is read</i>

Note: Command patterns other than that given in Command Table are prohibited. Otherwise, unexpected result will occur.

Remarks: "*" denote DON'T CARE bit

8.1 Data Read / Write

To read data from the GDDRAM, 5Dhex command should be executed then input High to $\overline{R/W}$ (\overline{WR}) pin and $\overline{D/C}$ pin for 6800-series parallel mode. Low to $\overline{E(RD)}$ pin and High to $\overline{D/C}$ pin for 8080-series parallel mode. No data read is provided for serial mode. In normal mode, GDDRAM column address pointer will be increased by one automatically after each data read in 8-levels gray scale mode OR after each 3-bytes data read in 16-levels gray scale mode. Also, a dummy read is required before the first data is read. See Figure 3 in Functional Description.

To write data to the GDDRAM, input Low to $\overline{R/W}$ (\overline{WR}) pin and High to $\overline{D/C}$ pin for 6800-series parallel mode. For serial interface, it will always be in write mode. GDDRAM column address pointer will be increased by one automatically after each data write in 8-levels gray scale mode OR each 3-bytes data write in 16-levels scale mode. The address will be reset to 0 in next data read/write operation is executed when it is 97.

www.DataSheet4U.com

9 COMMAND DESCRIPTIONS

9.1 Set Column Address (15 Hex)

This command specifies the 8-bit column address of the display data RAM. The start and the end column address are specified by this command. The driver supports up to 98 columns. As the addresses are incremented from the start column to the end column in the column direction scan, the page address is automatically incremented by 1. The column address is then returned to the start column. The column address will be increased by each data access after it is preset by the MCU. Start column < End column must be maintained.

RGB Alignment using 8-levels gray scale mode																						
LCD Read Direction		Column																				
		P11:0			0			1			2			3			96			97		
BLOCK	P10:0	P10:1	Color		R		G		B		R		G		B		R		G		B	
			D7	D4	D1	D7	D4	D1	D7	D4	D1	D7	D4	D1	D7	D4	D1	D7	D4	D1	D7	D4
Page		Data		D6	D3	D0	D6	D3	D0	D6	D3	D0	D6	D3	D0	D6	D3	D0	D6	D3	D0	
0	0	67																				
	1	66																				
	2	65																				
	3	64																				
1	4	63																				
	5	62																				
	6	61																				
	7	60																				
:	:	:																				
:	:	:																				
:	:	:																				
:	:	:																				
:	:	:																				
:	:	:																				
:	:	:																				
:	:	:																				
14	56	11																				
	57	10																				
	58	9																				
	59	8																				
15	60	7																				
	61	6																				
	62	5																				
	63	4																				
16	64	3																				
	65	2																				
	66	1																				
	67	0																				

SEGMENT OUTPUTS	COL0	COL1	COL2	COL3	COL4	COL5	COL6	COL7	COL8	COL9	COL10	COL11		COL288	COL289	COL290	COL291	COL292	COL293
-----------------	------	------	------	------	------	------	------	------	------	------	-------	-------	--	--------	--------	--------	--------	--------	--------

COMMON OUTPUTS	COM0	COM1	COM2	COM3	COM4	COM5	COM6	COM7	:	:	:	:	:	:	:	:	:	:	:	COM56	COM57	COM58	COM59	COM60	COM61	COM62	COM63	COM64	COM65	COM66	COM67
----------------	------	------	------	------	------	------	------	------	---	---	---	---	---	---	---	---	---	---	---	-------	-------	-------	-------	-------	-------	-------	-------	-------	-------	-------	-------

Table 7 - RAM arrangements of 8-levels gray scale mode

9.2 Set Page Address (75 Hex)

This command enters the page address from 0 to 67 to the RAM page register for read/write operations. The driver supports up to 68 lines. All in all, there are 68 pages. As the addresses are incremented from the start page to the end page in the page direction scan, the column address is incremented by 1. The page address is then returned to the start page. Start page < End page must be maintained.

9.3 Set COM Output Scan Direction (BB Hex)

This command sets the scan direction of the COM output allowing layout flexibility in LCD module assembly. Please refer to the Table 5 on Page 24 for detail mapping. In addition, the display will have immediate effect once this command is issued. That is, if this command is sent during normal display, the graphic display will have vertical flipping effect.

9.4 Set Data Output Scan Direction (BC Hex)

This command sets the DDRAM such that the MPU operates the display data in the internal RAM.

A. Normal or Inverse page/column/scan directions

The Data Scan direction can be set to either normal or inverse display page and column address scan direction. The column and the page direction are illustrated in the Figure 7 and Figure 8 on page 35 & 36, and Figure 9 on page 36 for example of Normal or Reverse page/column/ scan directions.

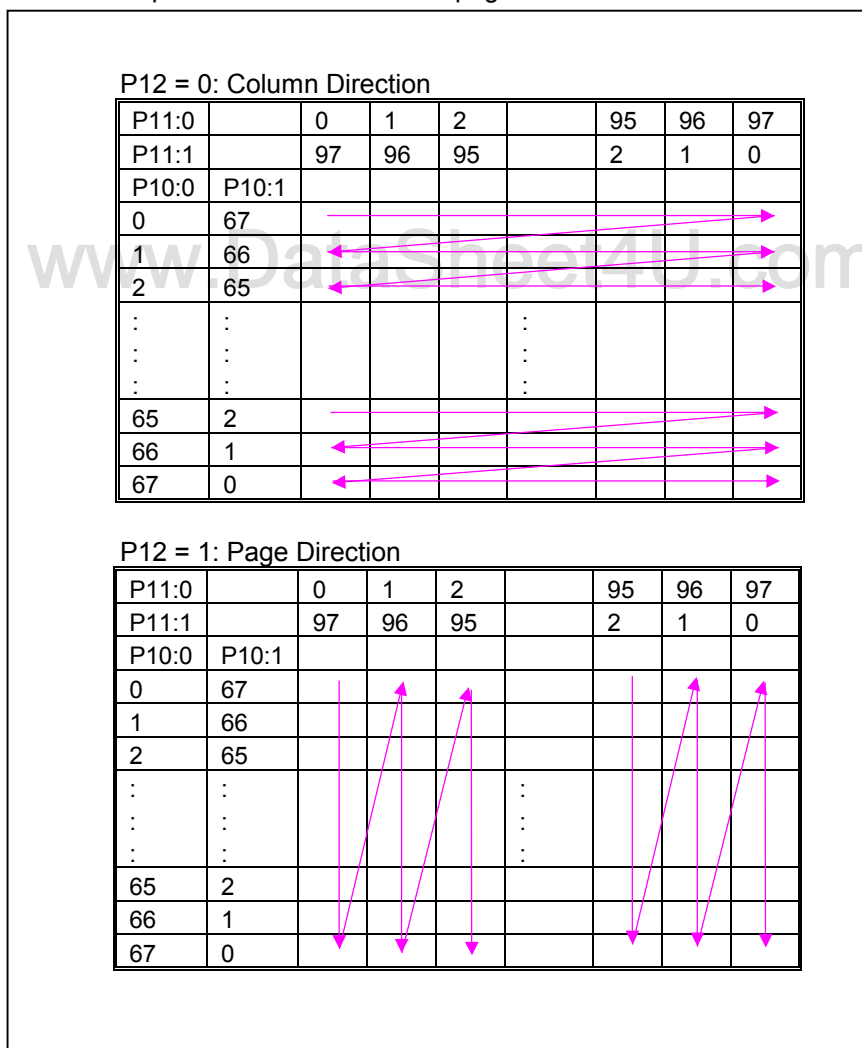

Figure 7 - column and page scan direction of 8-level gray scale mode

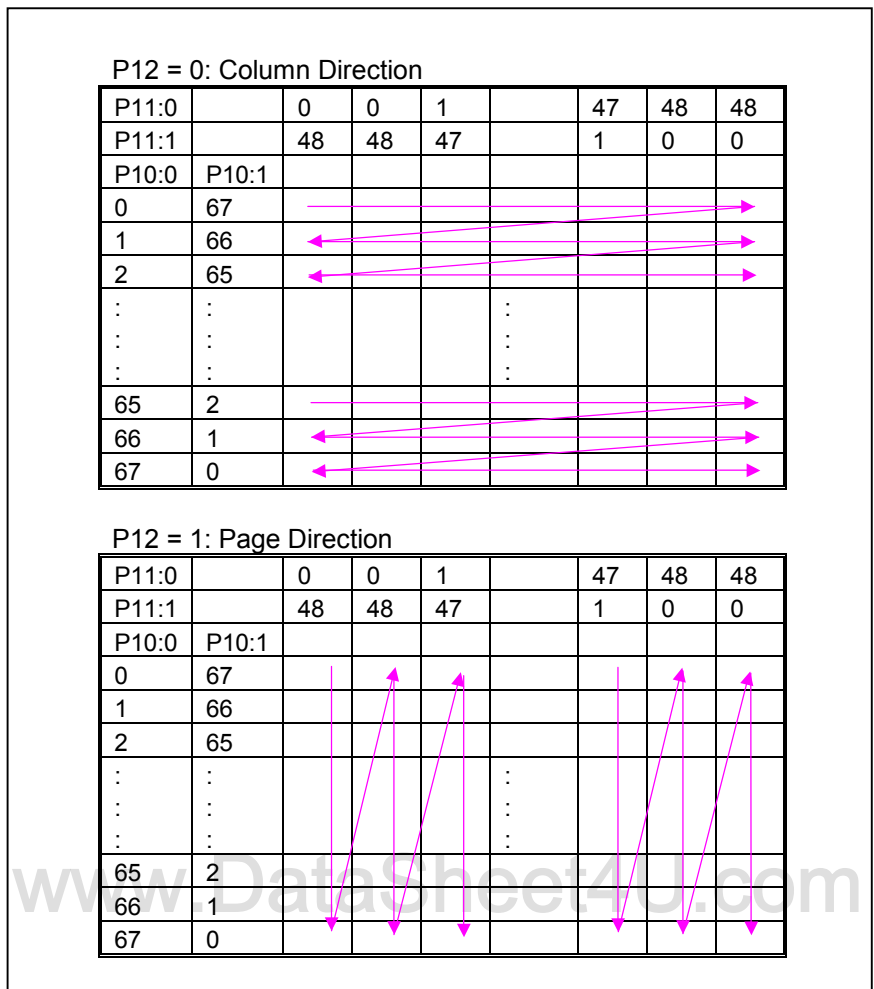

Figure 8 - column and page scan direction of 16-level gray scale mode

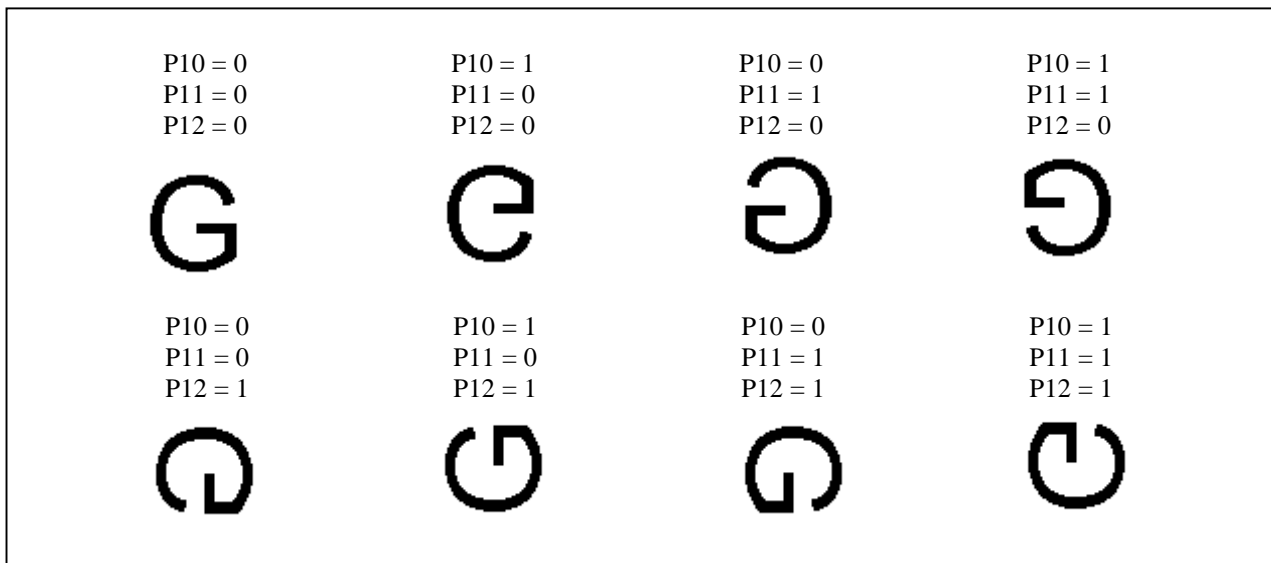

Figure 9 – Example of Normal or Reverse page/column/ scan directions

The parameters following the command set data output scan direction specifies the RGB arrangement and the selection of various gray-scale modes. Please find the information of the RGB arrangement and the gray scale mode in the following section.

B. RGB arrangement mode

The RGB arrangement mode can be selected according to the following table. Three selection bits will give eight combinations of the RGB arrangements. Each combination set will specify the Red, Green and Blue segment output arrangement in odd and even page.

P22, P21, P20	LINE	COL0	COL1	COL2	COL3	COL4	COL5	COL6	COL7	...	COL293
000	Even page	R	G	B	R	G	B	R	G	...	B
	Odd page	R	G	B	R	G	B	R	G	...	B
001	1	B	G	R	B	G	R	B	G	...	R
	2	B	G	R	B	G	R	B	G	...	R
010	1	R	G	B	B	G	R	R	G	...	R
	2	R	G	B	B	G	R	R	G	...	R
011	1	B	G	R	R	G	B	B	G	...	B
	2	B	G	R	R	G	B	B	G	...	B
100	1	R	G	B	R	G	B	R	G	...	B
	2	B	G	R	B	G	R	B	G	...	R
101	1	B	G	R	B	G	R	B	G	...	R
	2	R	G	B	R	G	B	R	G	...	B
110	1	R	G	B	B	G	R	R	G	...	R
	2	B	G	R	R	G	B	B	G	...	B
111	1	B	G	R	R	G	B	B	G	...	B
	2	R	G	B	B	G	R	R	G	...	R

Table 9 - RGB Arrangement modes

C. Gray scale mode

The gray scale mode can be selected according to the following table. Two types of gray scale mode such that the device can display between 256 colors or 4096 colors.

P32	P31	P30	Numbers of Gary-scale
0	0	1	8 gray-scale mode
0	1	0	16 gray-scale mode

Table 10 - Gray scale selection mode

R(D7, D6, D5)	Black (0, 0, 0)	(0,0,1)	(0,1,0)	(0,1,1)	(1,0,0)	(1,0,1)	(1,1,0)	(1,1,1)	Red
G(D4, D3, D2)	Black (0, 0, 0)	(0,0,1)	(0,1,0)	(0,1,1)	(1,0,0)	(1,0,1)	(1,1,0)	(1,1,1)	Green
B(D1, D0)	Black (0, 0)	(0,1)	(0,1)	(0,1)	(1,0)	(1,0)	(1,0)	(1,1)	Blue
		Any one of above			Any one of above				

Figure 10 - Examples: 8 gray-scale display arrangement

Description of different gray-scale display

8-gray-scale display:

Table 7 on page 33 shows the arrangement of the display data. The data D7, D6, D5, D4, D3, D2, D1, D0 (RRRGGGBB) is converted into 4-bits data (RRRRGGGGBBBB). The 4-bits data is then stored into the GDDRAM.

16-gray-scale display:

Table 8 on page 34 shows the arrangement of the display data. The data D7, D6, D5, D4, D3, D2, D1, D0 is encoded and write into the GDDRAM in three operation cycles.

D7, D6, D5, D4, D3, D2, D1, D0: R1, R1, R1, R1, G1, G1, G1, G1 (1ST write)

D7, D6, D5, D4, D3, D2, D1, D0: B1, B1, B1, B1, R2, R2, R2, R2 (2ND write)

D7, D6, D5, D4, D3, D2, D1, D0: G2, G2, G2, G2, B2, B2, B2, B2 (3RD write)

9.5 Set Color Look Up Table (CE Hex)

This command transforms the display data (R: 3 bits, G: 3 bits, B: 2 bits) into 4-bit data. The 4 bit data will then be stored into the GDDRAM by choosing colors to represent red, green and blue from 4096 colors. When the GDDRAM output the data, the red, green and blue data are converted back to 8 bit data (R: 3 bits, G: 3 bits, B: 2 bits). The Color Look-up Table must be set when using 8-levels gray scale mode.

9.6 Set Display Control (CA Hex)

This command is used to select the duty ratio of the IC. All available driving duty can be selected using this command. The driving duty can be changed from 1/8 to 1/68.

9.7 Set Area Scroll (AA Hex)

This command specifies the portion of screen for scrolling. The command sets the starting block address, finishing block address, number of specific blocks and the area scroll mode of the area scrolling. Please be noted that the starting block address should be smaller than the finishing block address.

The block address increment direction is started at 0th block such that the GDDRAM address corresponds to the top of the fixed area. Similarly, the block address decrement direction is started at the 16th block such that the GDDRAM address corresponds to the bottom fixed area. The remaining block address excluding the top and the bottom fixed areas are assigned to the scroll plus the background areas.

The set area scroll function is divided into four parts.

Part I -Specify the top block address of the scroll + the background areas. Specify the 0th block for the top screen scroll or the whole screen scroll. The scroll start block address is also set at this top block address until the scroll start set command is executed.

Part II – Specify the bottom address of the scroll + background areas. Specify the 16th block for the bottom or the whole screen scroll.

Part III – Specify number of scrolled blocks = number of (Top fixed area + scroll area) blocks –1. When the bottom scroll or whole screen scroll is chosen, the resulted value is identical to the value stated in part II.

Part IV

Specify the area scroll type. Altogether there are four types of area scroll. Please refer to Table 11 for detail.

P41	P40	Types of Area Scroll
0	0	Center Screen Scroll
0	1	Top Screen Scroll
1	0	Bottom Screen Scroll
1	1	Whole Screen Scroll

Table 11 - Area scrolling selection modes

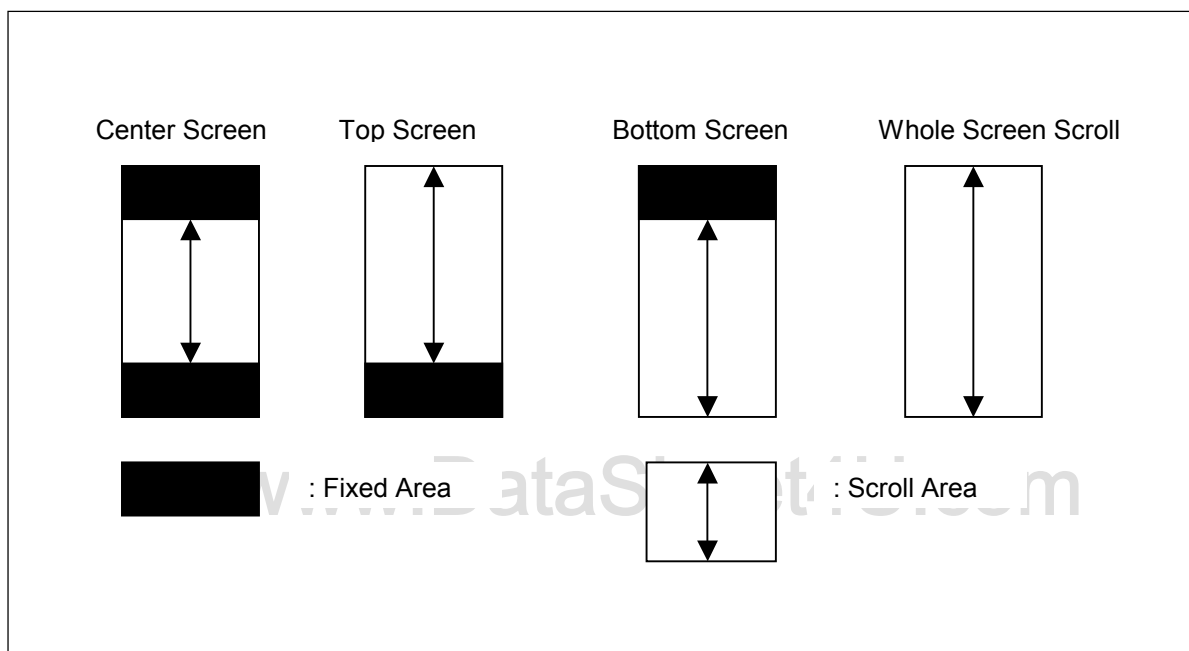

Figure 11 - Area scrolling selection modes

The area scroll function is executed by prompt in the set area scroll command following by changing the start block address by the set scroll start command. Figure 11 illustrates the operation model of the scrolling function.

Example: In the Center screen scroll of 1/48 duty (display range: 48 lines = 12 blocks)

Description	Command	Data
- Set Area Scroll	AAH	
- 8 lines (block 0 & block 1) are specified for the top fixed area - The Top Block Address = Number of the top fixed area = 8 / 4		02H
- 8 lines (block 15 & block 16) are specified for the bottom fixed area		
- 20 lines (block 10 to block 14) are specified the background areas - The Specified Bottom Block Address = Bottom Block Address + Number of Background area = 9 + (20 / 4) = 14 (0E Hex)		0EH
- 32 lines (block 2 to block 9) are specified the scroll area - Number of Specified Block = Top fixed area + Scroll Area - 1 = (8 / 4) + (32 / 4) - 1 = 9 (09 Hex)		09H
- Set area scroll mode – Center screen mode		00H
- Set Scroll start (Scroll range form 02H ~ 0EH)	ABH	02H

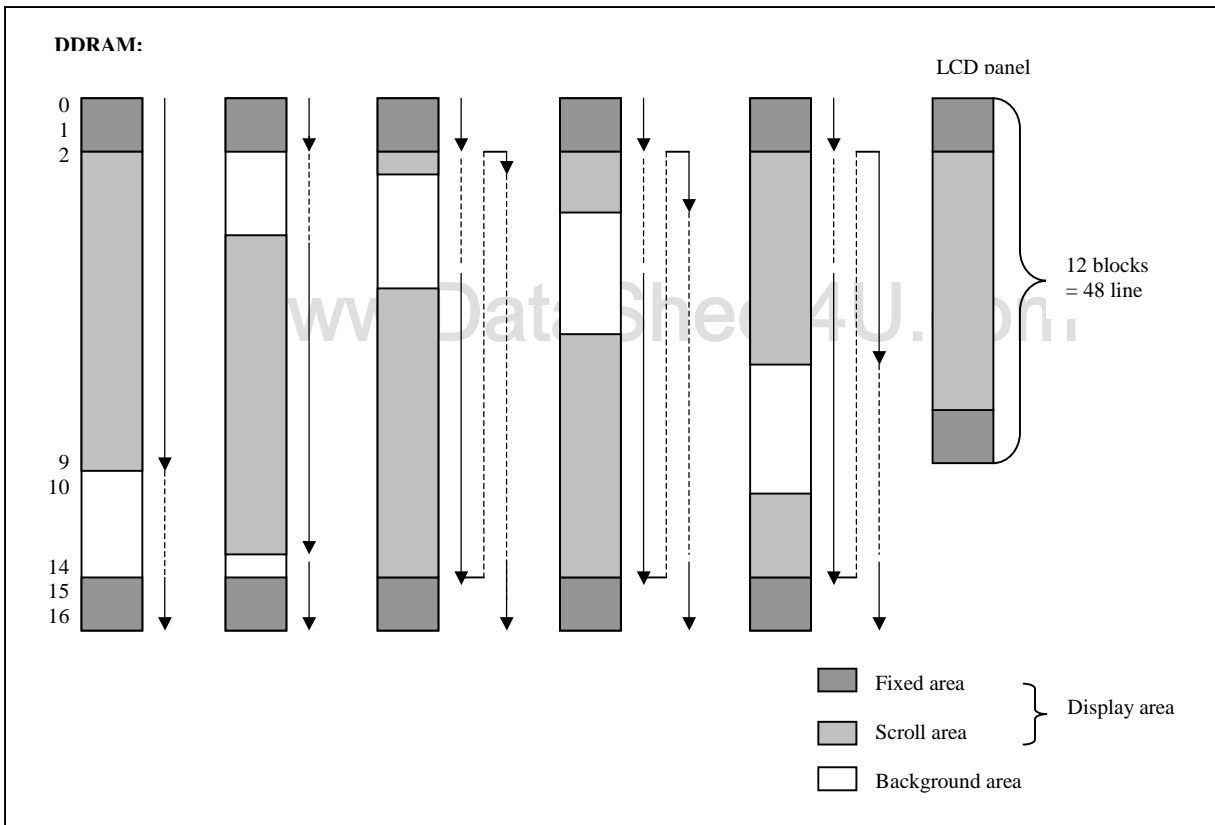

Figure 12 - GDDRAM updates for area scrolling

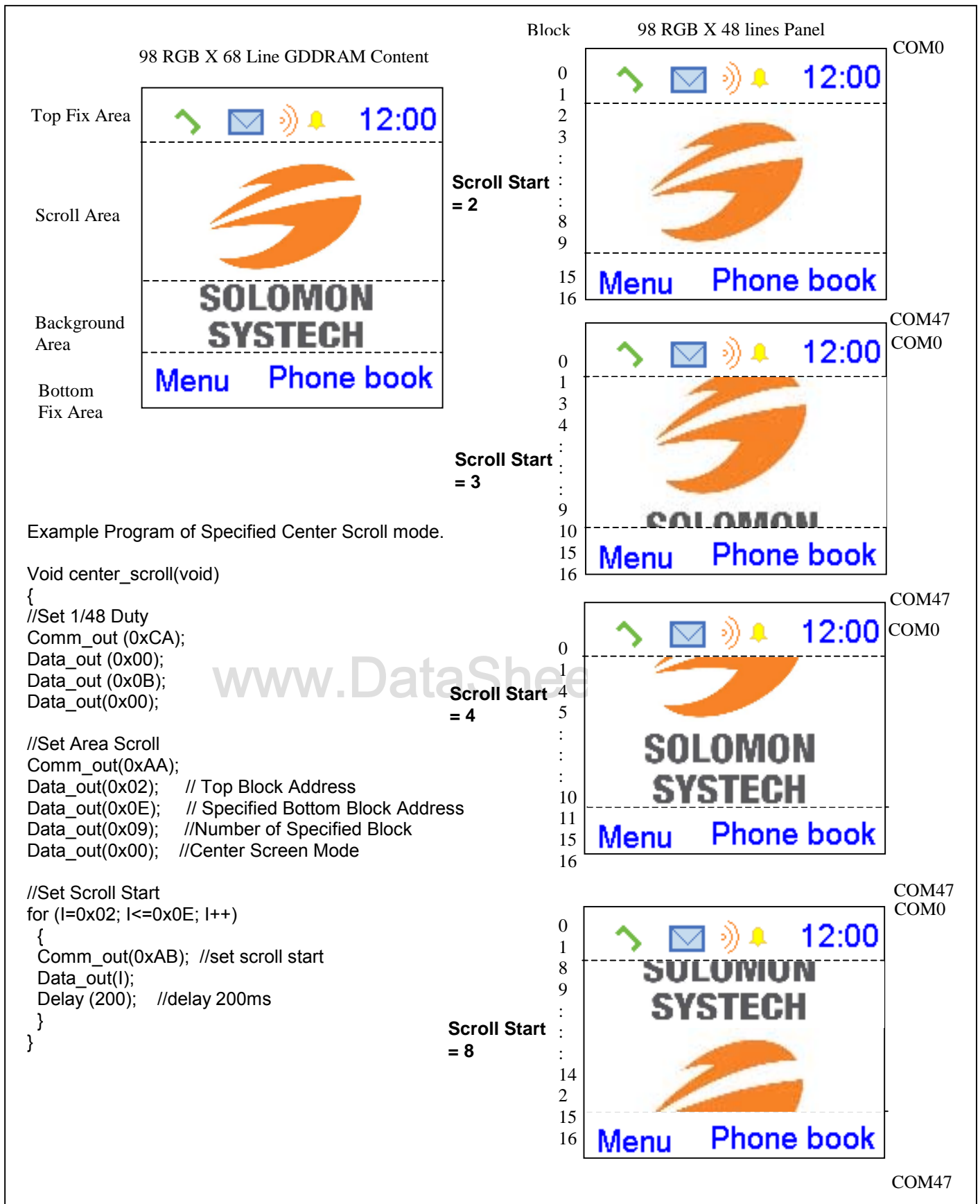

Figure 13 – Example of Specified Center Scroll Mode

9.8 Set Scroll Start (AB Hex)

This command specifies the starting block address of the area scrolling and then executes the area scroll by changing the start block address dynamically. Start block < End block must be maintained. Please be noted that the set scroll start command should be executed after the set area scroll command.

9.9 Set Power Control Register (20 Hex)

This command turns on/off the various power circuits associated with the chip. There are three power sub-circuits (reference voltage generator, internal regulator and voltage follower) could be turned on/off by this command. In addition, the configuration of the internal primary booster (3X/4X/5X/6X) can be selected by this command.

9.10 Set Contrast Level & Internal Regulator Ratio (81 Hex)

This command adjusts the contrast of the LCD panel by changing the LCD driving voltage, V_{OUT} , provided by the On-Chip power circuits. V_{OUT} is set with 64 steps (6-bit) in the contrast control register by a set of compound commands. Please refer to the Figure 14 for the contrast control process flow diagram.

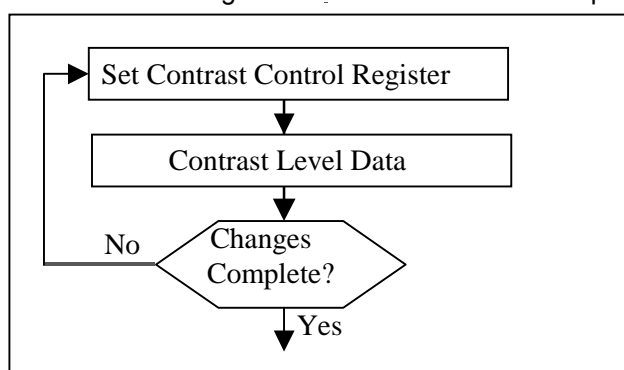

Figure 14 - Contrast Control Flow Set Segment Re-map

This command also sets the feedback gain of the internal regulator. There are altogether 8 internal regulator gains, which are used for the adjustment of V_{OUT} level. This command is to enable any one of the eight internal resistor (IRS) settings for different regulator gains when using internal regulator resistor network. The Contrast Control Voltage Range curves is referred to the following formula:

$$V_{out} = \left(1 + \frac{R_2}{R_1} \right) * V_{con}$$

, where $V_{ref} = 1.7V$

$$V_{con} = \left(1 - \frac{63 - \alpha}{210} \right) * V_{ref}$$

Remarks: $TC = -0.20\%/^{\circ}C$

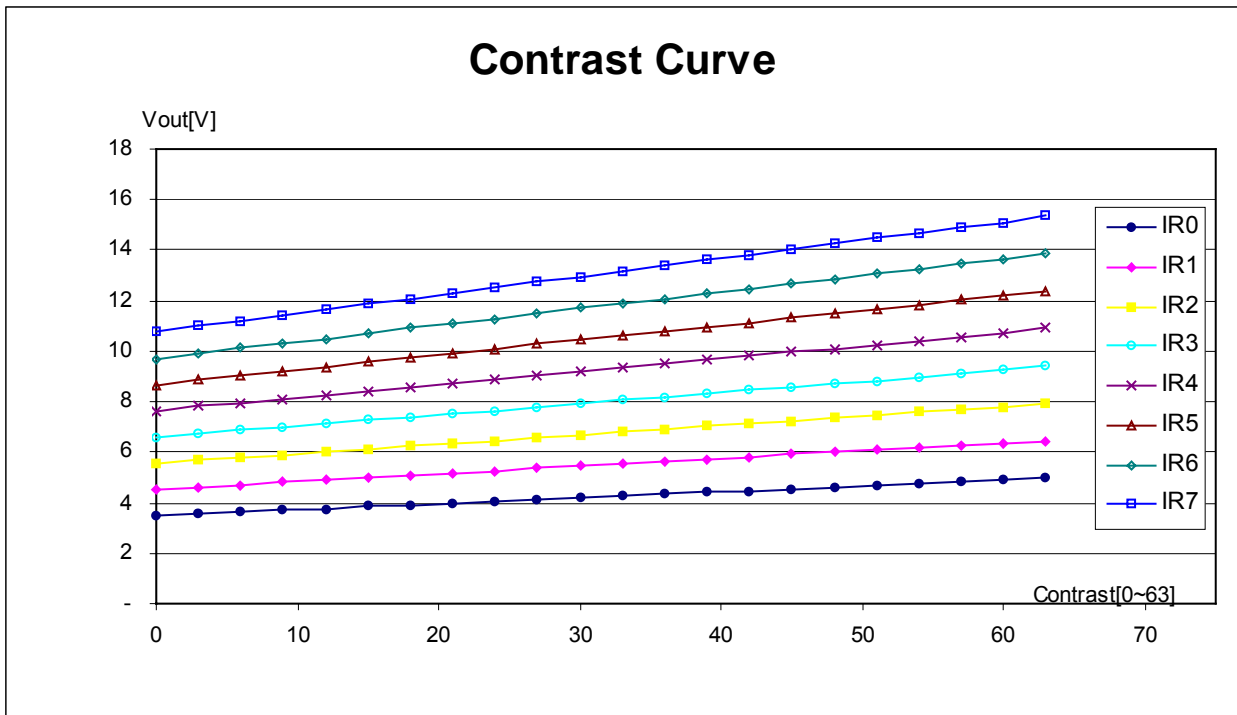

Figure 15 - Contrast Control Voltage Range Curve (VDD=2.7V; VCI=3V; Booster level = 6X; TC = -0.20%/°C)

Note: The Maximum operation voltage of V_{OUT} is 13.5V with panel load.

9.11 Set Increment/Decrement of the contrast set (D6/D7 Hex)

This command can increase the contrast step by +1 and decrease the contrast set by -1. It is the most convenient way to change the contrast of the display by programming.

9.12 Set Normal/Inverse Display (A6/A7 Hex)

For a normally white display panel, after the execution of Normal Display command, image data 000(RGB) indicates black pixel and image data FFF (RGB) indicate white pixel. For a normally black display panel, after the execution of Inverse Display command, image data 000(RGB) indicates Black pixel and image data FFF (RGB) indicate white pixel.

Example:

For a normal White display panel (Set Normal Display: A6 Hex):

RAM Content			Color
R	G	B	
F	F	F	White
0	0	0	Black
F	0	0	Red
0	F	0	Green
0	0	F	Blue

For a normal Black display panel (Set Normal Display: A7 Hex):

RAM Content			Color
R	G	B	
F	F	F	White
0	0	0	Black
F	0	0	Red
0	F	0	Green
0	0	F	Blue

9.13 Enter Partial Display (A8 Hex)

This command and the following parameters specify the display area of the partial display mode. The following figure shows the display and non-display area when the partial display mode is executed.

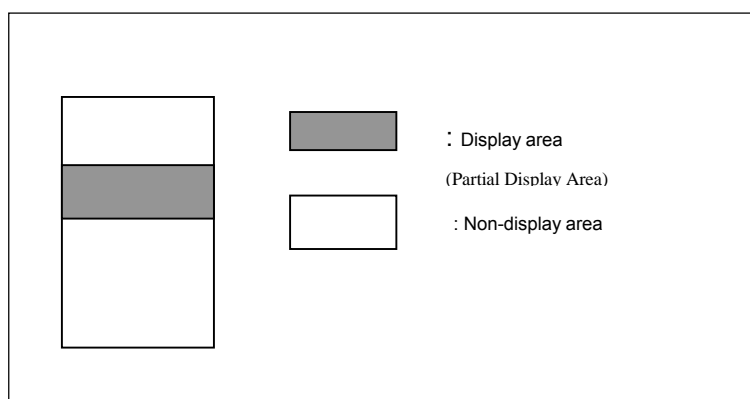

Figure 16 - Partial display mode

9.14 Exit Partial Display (A9 Hex)

This command exits the partial display mode.

9.15 Set Display On/Off (AE/AF Hex)

This command is used to turn the display on or off. When display off is issued with entire display is on, power save mode will be entered.

9.16 Enter/Exit sleep mode (94/95 Hex)

This command enter/exit the sleep mode.

9.17 Enable/Disable the internal oscillator (D1/D2 Hex)

This command enables or disables the internal oscillator. The internal oscillator is turned off after hardware or software reset.

9.18 Set Temperature compensation coefficient (82 Hex)

This command sets the average temperature gradients. Four sets of average temperature gradients can be selected. Please refer to the command table for detail description of the average temperature gradients. The default value of the temperature gradient is $-0.2\%/^{\circ}\text{C}$

9.19 NOP (25 Hex)

A command causing the chip takes No Operation.

9.20 Write display data mode (5C Hex)

This command is used to execute the write display data mode. The display data byte is directly written to the GDDRAM. Please be noted that the D/\bar{C} signal should be set to high during the display data is written to the GDDRAM.

9.21 Read display data mode (5D Hex)

This command is used to execute the read display data mode. The display data byte is directly read from the GDDRAM. Please be noted that the D/\bar{C} signal should be set to high during the display data is read from to the GDDRAM.

Graphic Command

9.22 Draw Line (83Hex)

Given the starting point (X1, Y1) and the ending point (X2, Y2), a line will be drawn with the color specified.

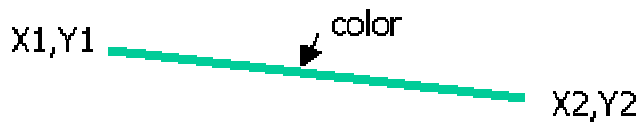

The following example illustrates the line drawing procedure.

1. Enter the "draw line mode" by execute the command 83H
2. Set the starting X-coordinates, X1. E.g., 00H.
3. Set the starting Y-coordinates, Y1. E.g., 00H.
4. Set the finishing X-coordinates, X2. E.g., 01H
5. Set the finishing Y-coordinates, Y2. E.g., 01H
6. Set the color to RGB = (0,1,0) e.g., 0FH following by 00H

Result: A color line will be drawn between coordinates (0,0) and (1,1)

Remarks: $X1 \leq 97$; $Y1 \leq 67$; $X2 \leq 97$; $Y2 \leq 67$

9.23 Fill Enable/Disable (92 Hex)

This command allows the fill color option to be enabled or disabled. This command is applicable to the Draw Rectangle feature. When the selection bit is "0", the fill color option is disabled. When the selection bit is "1", the fill color option is enabled.

9.24 Draw rectangle (84 Hex)

Given the starting point (X1, Y1) and the ending point (X2, Y2), specify the width and height of a rectangle that will be drawn with the color specified. Remarks: If fill color option is disabled, the enclosed area will not be filled.

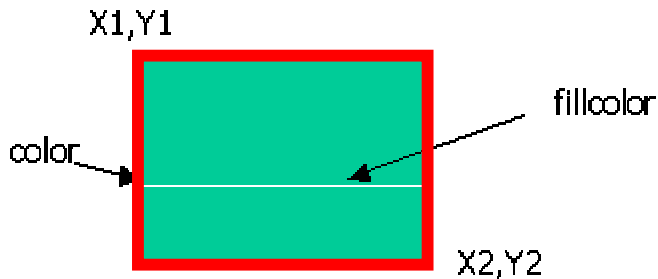

The following example illustrates the rectangle drawing procedure.

1. Enter the "draw rectangle mode" by execute the command 8AH
2. Set the starting X-coordinates, X1. E.g., 00H.
3. Set the starting Y-coordinates, Y1. E.g., 00H.
4. Set the finishing X-coordinates, X2. E.g., 02H
5. Set the finishing Y-coordinates, Y2. E.g., 02H
6. Set the color to RGB = (1,0,0) e.g., F0H following by 00H
7. Set the filled color to RGB = (0,1,0) e.g., 0FH following by 00H

Result: A filled color square will be drawn with the coordinates of the top left hand corner at (0,0) and the coordinates of the bottom right hand corner at (2,2)

Remarks: $X1 \leq X2$; $Y1 \leq Y2$; $X2 \leq 97$; $Y2 \leq 67$

9.25 Copy (8A Hex)

Copy the rectangular region defined by the starting point (X1, Y1) and the ending point (X2, Y2) to location (X3, Y3). There are two possible results with the command copy executed depending on the setting of the start point coordinates and end point coordinates.

The following example illustrates the copy procedure.

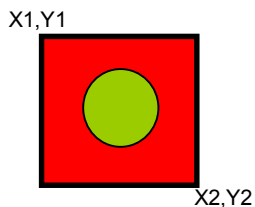

Case 1 – The overlap region will superimpose.

1. Enter the “copy mode” by execute the command 84H
2. Set the starting X-coordinates, X1. E.g., 00H.
3. Set the starting Y-coordinates, Y1. E.g., 00H.
4. Set the finishing X-coordinates, X2. E.g., 02H
5. Set the finishing Y-coordinates, Y2. E.g., 02H
6. Set the New X-coordinates, X3. E.g., 01H
7. Set the New Y-coordinates, Y3. E.g., 01H



Case 2 – The original content remains unchanged

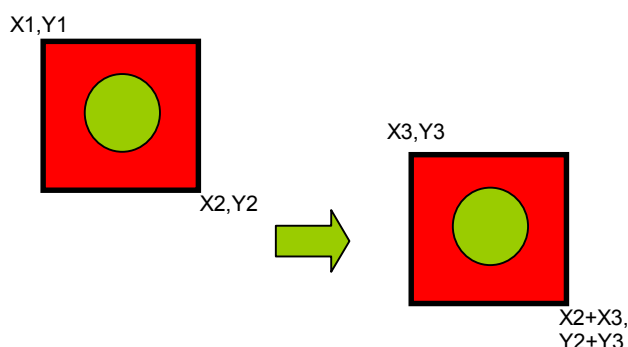

1. Enter the “copy mode” by execute the command 84H
2. Set the starting X-coordinates, X1. E.g., 00H.
3. Set the starting Y-coordinates, Y1. E.g., 00H.
4. Set the finishing X-coordinates, X2. E.g., 01H
5. Set the finishing Y-coordinates, Y2. E.g., 01H
6. Set the New X-coordinates, X3. E.g., 09H
7. Set the New Y-coordinates, Y3. E.g., 09H

Remarks: $X1 \leq X2$; $Y1 \leq Y2$; $X2 \leq 97$; $Y2 \leq 67$

9.26 Dim Window (8C Hex)

This command will dim the window area specify by starting point (X1, Y1) and the ending point (X2, Y2). After the execution of this command, the selected window area will be dimmed by 75% white. Additional execution of this command over the same window area will not change the data content.

Remarks: $X1 \leq X2$; $Y1 \leq Y2$; $X2 \leq 97$; $Y2 \leq 67$

9.27 Clear Window (8E Hex)

This command sets the window area specify by starting point (X1, Y1) and the ending point (X2, Y2) to clear the window display. The contrast of the window will be set to zero.

Remarks: $X1 \leq X2$; $Y1 \leq Y2$; $X2 \leq 97$; $Y2 \leq 67$

www.DataSheet4U.com

Extended Command

9.28 Set biasing ratio (FB Hex)

This command selects a suitable bias ratio (1/4 to 1/8) required for driving the particular LCD panel in use.

9.29 Set Frame Frequency (F2 Hex)

This command specifies the frame frequency so as to minimize the flickering due to the ac main frequency. The frequency is set to 78Hz after POR.

9.30 Set N-line inversion (F2 Hex)

Number of line inversion is set by this command for reducing crosstalk noise. 2 to 32-line inversion operations could be selected. At POR, this operation is set to 0110b (7 lines). It should be noted that the total number of mux should NOT be a multiple of the inversion number (n). Or else, some lines will not change their polarity during frame change.

9.31 Set N-line inversion Mode (F2 Hex)

This command specifies the N-line inversion mode. At POR, The polarity will toggle per N-line and each frame, otherwise, the polarity toggle per N-line only.

9.32 Select PWM/FRC (F7 Hex)

This command set the Pulse Width Modulation, Frame Rate Control or mix of FWM & FRC.

9.33 OTP setting and programming (F6/F8 Hex)

OTP (One Time Programming) is a method to adjust V_{OUT} . In order to eliminate the variations of LCD module in term of contrast level, OTP can be used to achieve the best contrast of every LCD modules.

OTP setting and programming should include two major steps. Find the OTP offset and OTP programming as following,

Step 1. Find OTP offset

- (1) Hardware Reset (sending an active low reset pulse to $\overline{\text{RES}}$ pin)
- (2) Send original initialization routines
- (3) Set and display any test patterns
- (4) Adjust the contrast value (C:0x81, D:0x00~0x3F, D: 0x00 ~ 0x07) until there is the best visual contrast
- (5) OTP setting steps = Contrast value of the best visual contrast - Contrast value of original initialization

Example 1:

Contrast value of original initialization = 0x20

Contrast value of the best original initialization = 0x24

OTP offset value = 0x24 - 0x20 = +4

OTP setting command should be (C: 0xF6, D: 0x14, D: 0x0A)

Example 2:

Contrast value of original initialization = 0x20

Contrast value of the best original initialization = 0x1B

OTP setting = 0x1B - 0x20 = -5

OTP setting command should be (C:0xF6, D: 0x1B, D: 0x0A)

Step 2. OTP programming

- (6) Hardware Reset (sending an active low reset pulse to $\overline{\text{RES}}$ pin)
- (7) Enable Oscillator (C: 0xD1) and Exit Sleep Mode (C: 0x94)
- (8) Connect an external V_{OUT} by closing SW1 (see diagram below)
- (9) Send OTP setting commands that we find in step 1 (C: 0xF6, D: 0x10~0x1F, D: 0x0A)
- (10) Send OTP programming command (C: 0xF8)
- (11) Wait at least 2 seconds
- (12) Disconnect the external V_{out} by opening SW1
- (13) Discharge the capacitor C by closing the switch SW2 and wait for 1 second
- (14) Hardware Reset
- (15) Verify the result by repeating step 1. (2) – (3)

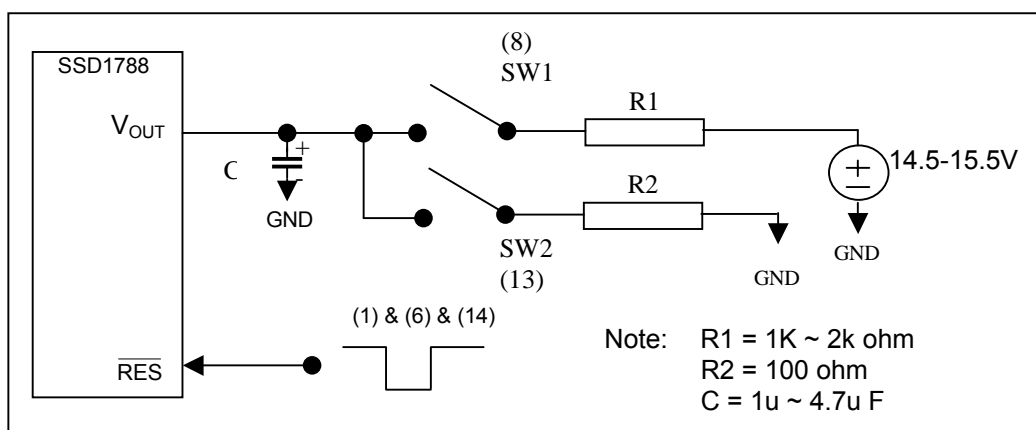

Figure 17 – OTP programming circuitry

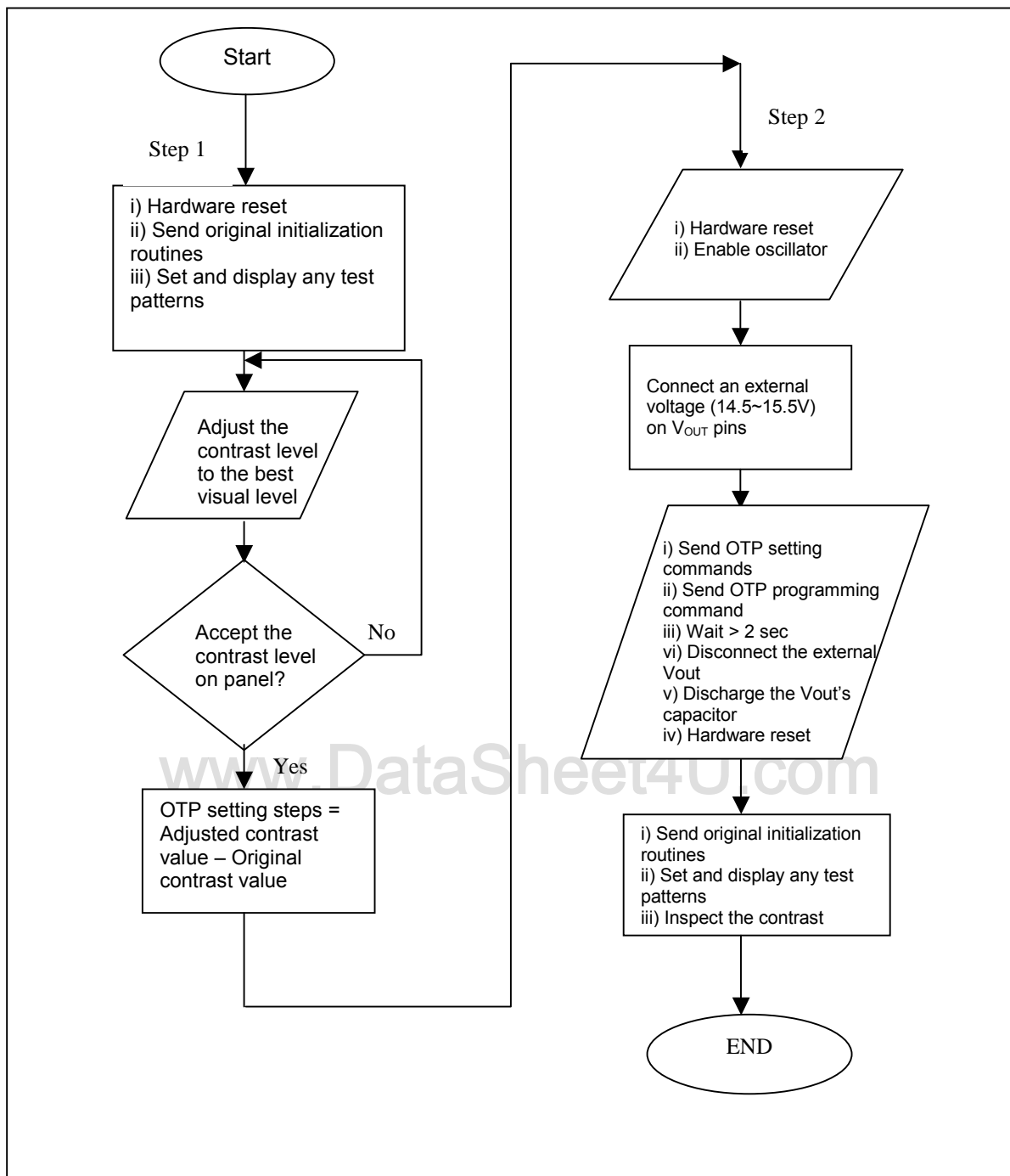

Figure 18 – Flow chart of OTP programming Procedure

OTP Example program

Find the OTP offset:

1. Hardware reset by sending an active low reset pulse to $\overline{\text{RES}}$ pin
2. COMMAND(0XD1); \\ Enable oscillator;
COMMAND(0X94); \\ exit sleep mode;
3. COMMAND(0X0B); \\ turn on the reference voltage generator, internal regulator and voltage follower; Select booster level.
4. COMMAND(0XCA) \\ Set Duty ratio
DATA(0X10) \\ 68Mux $[(68 / 4) - 1 = 16(\text{decimal}) / 10(\text{Hex})]$
COMMAND(0XF7) \\ Set PWM/FRC
DATA(0X28) \\ pure PWM
DATA(0X2C)
DATA(0X05)
COMMAND(0XFB) \\ Set Biasing ratio
DATA(0X3) \\ 1/7
5. COMMAND(0X81) \\ Set target gain and contrast.
DATA(0X14) \\ contrast = 20
DATA(0X05) \\ IR5 => gain = 7.16
6. \\ Set target display contents
COMMAND(0X15) \\ set column address
DATA(0x00) \\ set start column address at 0
DATA(0X61) \\ set end column address at 97
COMMAND(0X75) \\ set page address
DATA(0X00) \\ set start page address at 0
DATA(0X43) \\ set end page address at 67
COMMAND(0X5C) \\ write target content to GDDRAM
DATA(...)
COMMAND(0xAF) \\ display on
7. OTP offset calculation... target OTP offset value is +3

OTP programming:

8. Hardware reset by sending an active low reset pulse to $\overline{\text{RES}}$ pin
9. COMMAND(0XAB) \\ Enable Oscillator
10. COMMAND(0x94) \\ Exit Sleep Mode
11. Connect a external V_{OUT} (14.5V~15.5V)
12. COMMAND(0XF6) \\ Set OTP offset value to +3 (0011)
DATA(0X13) \\ 0001 $X_3X_2X_1X_0$, where $X_3X_2X_1X_0$ is the OTP offset value
DATA(0x0A) \\ Enable the OTP setting
13. COMMAND(0XF8) \\ Send the OTP programming command.
14. Wait at least 2 seconds for programming wait time.
15. Disconnect an external V_{out}
16. Discharge the V_{out} 's capacitor
17. Hardware reset by sending an active low reset pulse to $\overline{\text{RES}}$ pin

Verify the result:

18. After OTP programming, procedure 2 to 5 are repeated for inspection of the contrast on the panel.

Read Status Command

9.34 Status register read

This command will output the status of the device. The following parameters can be monitored by the status read register.

1. Various area scroll mode
2. Column scan direction
3. Page scan direction
4. Display ON/OFF
5. Sleep mode ON/OFF
6. Display Normal/Inverse
7. Partial display mode ON/OFF

www.DataSheet4U.com

10 MAXIMUM RATINGS

Table 12 - Maximum Ratings (Voltage Referenced to V_{SS})

Symbol	Parameter	Value	Unit
V_{DD}	Supply Voltage	-0.3 to +4.0	V
V_{OUT}		-0.3 to 15	V
V_{CI}	Input Voltage	$V_{SS}-0.3$ to 4.0	V
I	Current Drain Per Pin Excluding V_{DD} and V_{SS}	25	mA
T_A	Operating Temperature	-40 to +85	°C
T_{stg}	Storage Temperature	-65 to +150	°C
R_{on}	Input Resistance	1000	ohm

Maximum ratings are those values beyond which damages to the device may occur. Functional operation should be restricted to the limits in the Electrical Characteristics tables or Pin Description section

This device contains circuitry to protect the inputs against damage due to high static voltages or electric fields; however, it is advised that normal precautions to be taken to avoid application of any voltage higher than maximum rated voltages to this high impedance circuit. For proper operation it is recommended that V_{CI} and V_{out} be constrained to the range $V_{SS} < V_{DD} \leq V_{CI} < V_{OUT}$. Reliability of operation is enhanced if unused input is connected to an appropriate logic voltage level (e.g., either V_{SS} or V_{DD}). Unused outputs must be left open. This device may be light sensitive. Caution should be taken to avoid exposure of this device to any light source during normal operation. This device is not radiation protected.

www.DataSheet4U.com

11 DC CHARACTERISTICS

Table 13 - DC Characteristics

(Unless otherwise specified, Voltage Referenced to V_{SS} , $V_{DD} = 2.4$ to $3.6V$, $T_A = -40$ to $85^\circ C$)

Symbol	Parameter	Test Condition	Min	Typ	Max	Unit
V_{DD}	System power supply pins of the logic block Range	Recommend Operating Voltage Possible Operating Voltage	2.4	2.7	3.6	V
V_{DDIO}	System power supply pins of logic block Range	Recommend Operating Voltage Possible Operating Voltage	1.2	-	V_{DD}	V
V_{CI}	Booster Reference Supply Voltage Range	Recommend Operating Voltage Possible Operating Voltage	V_{DD}	-	3.6	V
I_{AC}	Access Mode Supply Current Drain (V_{DD} Pins)	$V_{DD} = 2.7V$, Voltage Generator On, 5X DC-DC, Write accessing, $T_{cyc} = 5MHz$, Typ. Osc. Freq., Display On, no panel attached.	-	400	1000	μA
I_{DP2}	Display Mode Supply Current Drain (V_{DD} Pins)	$V_{DD} = 2.775V$, $V_{OUT} = 10.3V$, Voltage Generator On, 5X DC-DC Converter Enabled, R/W(WR) Halt, Typ. Osc. Freq., Display On, no panel attached.	-	300	450	μA
I_{SLEEP}	Sleep Mode Supply Current Drain (V_{DD} Pins)	$V_{DD} = 2.775V$, LCD Driving Waveform Off, Oscillator Off, R/W(WR) halt.	-	2	5	μA
V_{OUT}	LCD Driving Voltage Generator Output (V_{out} Pin)	Display On, Voltage Generator Enabled, DC-DC Converter Enabled, Typ. Osc. Freq., Regulator Enabled, Divider Enabled.	5	-	13.5	V
	V_{OUT} Converter Efficiency	6X boost, no panel loading	93	99	-	%
V_{REF}	Internal Reference Voltage ($T = 25^\circ C$)	$TC0 = -0.10\%/^\circ C$	1.64	1.69	1.74	V
		$TC1 = -0.15\%/^\circ C$	1.64	1.69	1.74	V
		$TC2 = -0.20\%/^\circ C$ (POR)	1.65	1.70	1.75	V
		$TC3 = -0.25\%/^\circ C$	1.65	1.70	1.75	V
	Reference Voltage ($T = 25^\circ C$)	TC2	1.65	1.70	1.75	V
	Reference Voltage ($T = -20^\circ C$)	TC2	1.79	1.85	1.91	V
	Reference Voltage ($T = 70^\circ C$)	TC2	1.50	1.55	1.60	V
V_{OH1}	Logic High Output Voltage	$I_{out} = -100 A$	0.9* V_{DDIO}	-	V_{DDIO}	V
V_{OL1}	Logic Low Output Voltage	$I_{out} = 100 A$	0	-	$0.1 * V_{DDIO}$	V
V_{IH1}	Logic High Input voltage		0.8* V_{DDIO}	-	V_{DDIO}	V
V_{IL1}	Logic Low Input voltage		0	-	$0.2 * V_{DDIO}$	V
I_{OH}	Logic High Output Current Source	$V_{out} = V_{DD} - 0.4V$	50	-	-	μA
I_{OL}	Logic Low Output Current Drain	$V_{out} = 0.4V$	-	-	-50	μA
I_{OZ}	Logic Output Tri-state Current Drain Source		-1	-	1	μA
I_{IL}/I_{IH}	Logic Input Current		-1	-	1	μA
C_{IN}	Logic Pins Input Capacitance		-	5	7.5	pF
ΔV_{OUT}	Variation of V_{OUT} Output (V_{DD} is fixed)	Regulator Enabled, Internal Contrast Control Enabled, Set Contrast Control Register = 0	-2	0	2	%

Symbol	Parameter	Test Condition	Min	Typ	Max	Unit
TC0	Average Temperature Gradient Flat Temperature Coefficient	Voltage Regulator Enabled	0	-0.10	-0.12	%/°C
TC1	Temperature Coefficient 1		-0.12	-0.15	-0.17	%/°C
TC2	Temperature Coefficient 2 (POR)		-0.17	-0.20	-0.22	%/°C
TC3	Temperature Coefficient 3		-0.22	-0.25	-0.27	%/°C

The formula for the temperature coefficient is:

$$TC(\%) = \frac{V_{ref\ at\ 50^{\circ}C} - V_{ref\ at\ 0^{\circ}C}}{50^{\circ}C - 0^{\circ}C} \times \frac{1}{V_{ref\ at\ 25^{\circ}C}} \times 100\%$$

www.DataSheet4U.com

12 AC CHARACTERISTICS

Table 14 - AC Characteristics (Unless otherwise specified, Voltage Referenced to V_{SS} , $V_{DD} = 2.7V$, $T_A = 25^\circ C$)

Symbol	Parameter	Test Condition	Min	Typ	Max	Unit
Fosc	Oscillation Frequency of Display Timing Generator for: 68 MUX Mode	Internal Oscillator Enabled (default), $V_{DD} = 2.7V$	465.12	477.36	489.6	kHz
F _{FRM}	Frame Frequency for: 68 MUX Mode	b. 98 RGB x 68 Graphic Display Mode, Display ON, Internal Oscillator Disabled, External clock with freq., Fext, feeding to CL pin.	76	78	80	Hz

Remarks: Fext stands for the frequency value of external clock feeding to the CL pin
Fosc stands for the frequency value of internal oscillator

www.DataSheet4U.com

Table 15 – Parallel 6800-series Interface Timing Characteristics $(T_A = -40$ to 85°C , $V_{DD} = 2.6\text{V}$ to 3.6V , $V_{DDIO} = 1.2\text{V}$ to V_{DD})

Symbol	Parameter	Min	Typ	Max	Unit
t_{cycle}	Clock Cycle Time (write cycle)	130	-	-	ns
PW_{CSL}	Control Pulse Low Width	65	-	-	ns
PW_{CSH}	Control Pulse High Width	65	-	-	ns
t_{AS}	Address Setup Time	15	-	-	ns
t_{AH}	Address Hold Time	10	-	-	ns
t_{DSW}	Data Setup Time	10	-	-	ns
t_{DHW}	Data Hold Time	20	-	-	ns
t_{ACC}	Data Access Time	15	-	200	ns
t_{OH}	Output Hold time	20	-	60	ns

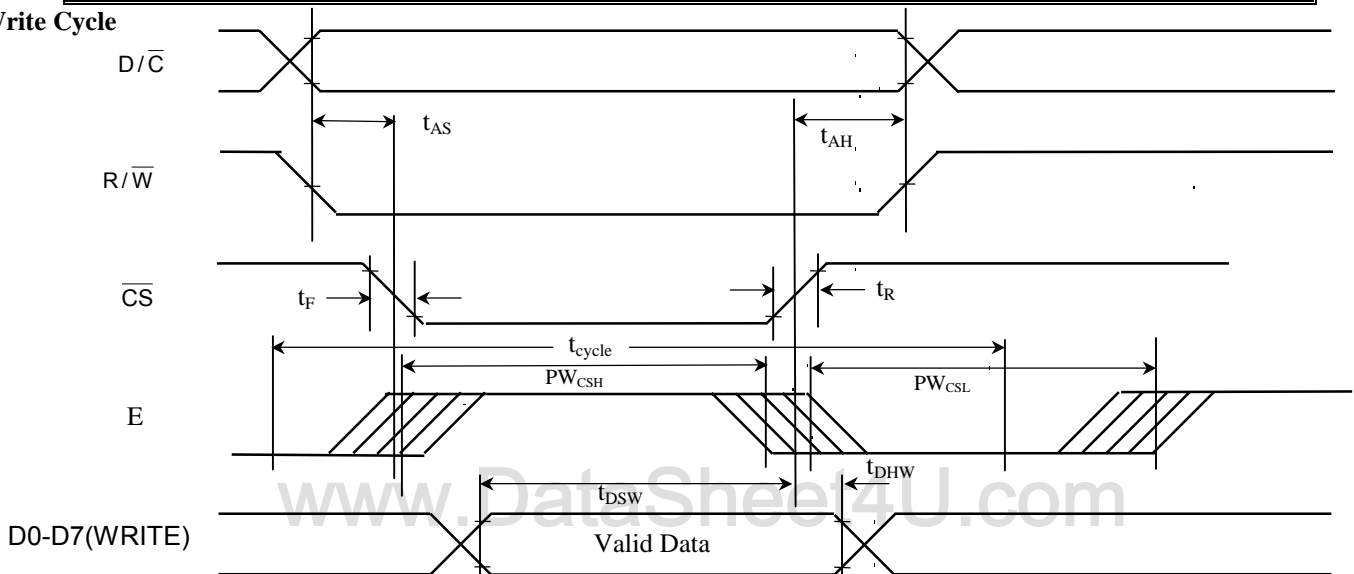
Write Cycle

The PW_{CSH} timing reference is 50% of the rising / falling edge of E or $\overline{\text{CS}}$ pin.

The t_{DSW} and t_{DHW} timing is reference to the 50% of rising / falling edge of E or $\overline{\text{CS}}$ pin.

Read Cycle**Figure 19 – Parallel 6800-series Interface Timing Characteristics (PS0 = H, PS1 = H)**

Table 16 – Parallel 8080-series Interface Timing Characteristics $(T_A = -40 \text{ to } 85^\circ\text{C}, V_{DD} = 2.6\text{V to } 3.6\text{V}, V_{DDIO} = 1.2\text{V to } V_{DD})$

Symbol	Parameter	Min	Typ	Max	Unit
t_{cycle}	Clock Cycle Time (write cycle)	130	-	-	ns
PW_{CSL}	Control Pulse Low Width	65	-	-	ns
PW_{CSH}	Control Pulse High Width	65	-	-	ns
t_{AS}	Address Setup Time	15	-	-	ns
t_{AH}	Address Hold Time	10	-	-	ns
t_{DSW}	Data Setup Time	10	-	-	ns
t_{DHW}	Data Hold Time	20	-	-	ns
t_{ACC}	Data Access Time	15	-	170	ns
t_{OH}	Output Hold time	20	-	60	ns

Write Cycle

The PW_{CSL} timing reference is 50% of the rising / falling edge of $\overline{\text{WR}}$ or $\overline{\text{CS}}$ pin.

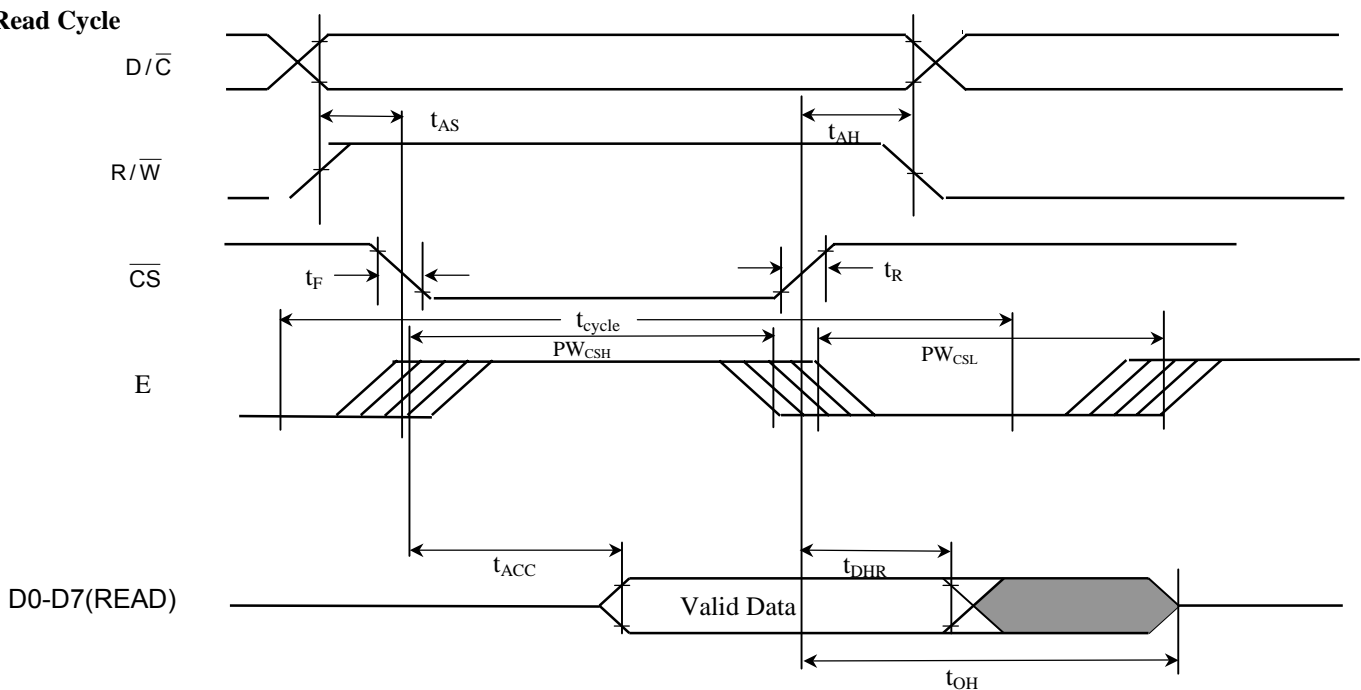
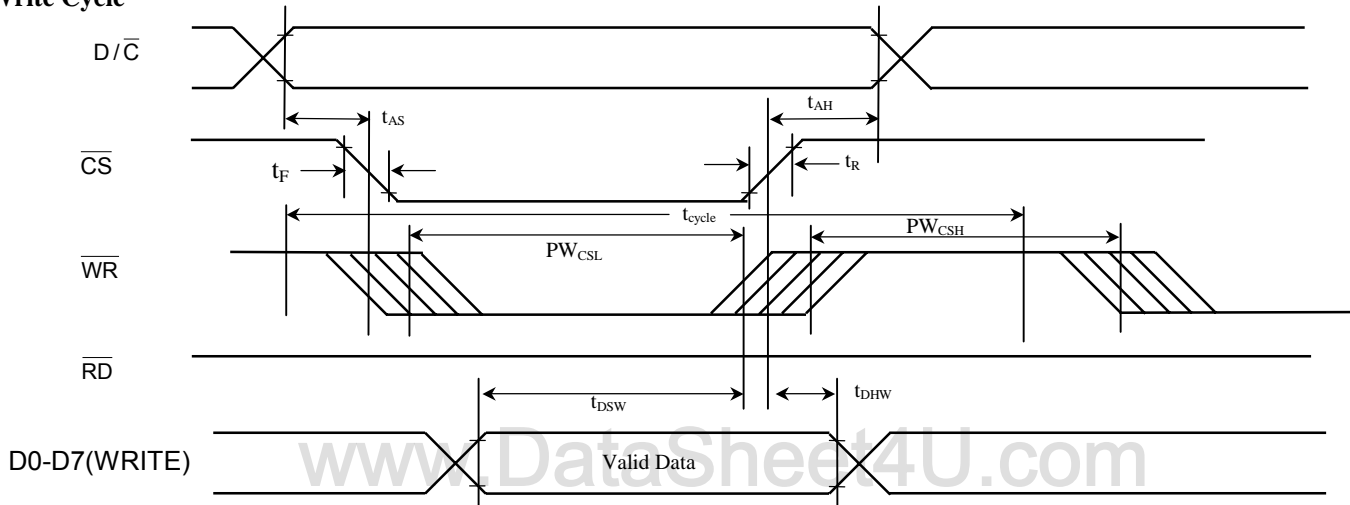
The t_{DSW} and t_{DHW} timing is reference to the 50% of rising / falling edge of $\overline{\text{WR}}$ or $\overline{\text{CS}}$ pin.

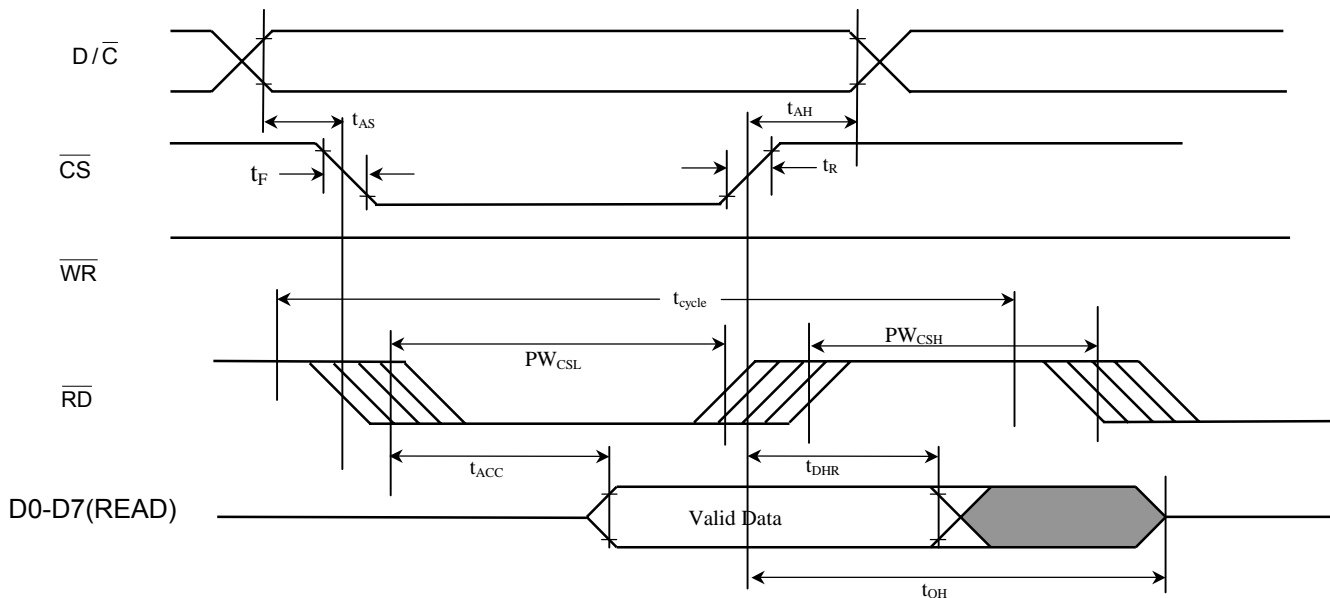
Read Cycle

The PW_{CSL} timing reference is 50% of the rising / falling edge of $\overline{\text{RD}}$ or $\overline{\text{CS}}$ pin.

The t_{DSW} and t_{DHW} timing is reference to the 50% of rising / falling edge of $\overline{\text{RD}}$ or $\overline{\text{CS}}$ pin.

Figure 20 – Parallel 8080-series Interface Timing Characteristics (PS0 = H, PS1 = L)

Table 17 – Parallel 6800-series Interface Timing Characteristics ($T_A = -40$ to 85°C , $V_{DD} = 2.4\text{V}$, $V_{DDIO} = 1.2\text{V}$ to V_{DD})

Symbol	Parameter	Min	Typ	Max	Unit
t_{cycle}	Clock Cycle Time (write cycle)	250	-	-	ns
PW_{CSL}	Control Pulse Low Width	125	-	-	ns
PW_{CSH}	Control Pulse High Width	125	-	-	ns
t_{AS}	Address Setup Time	15	-	-	ns
t_{AH}	Address Hold Time	10	-	-	ns
t_{DSW}	Data Setup Time	10	-	-	ns
t_{DHW}	Data Hold Time	20	-	-	ns
t_{ACC}	Data Access Time	15	-	170	ns
t_{OH}	Output Hold time	20	-	60	ns

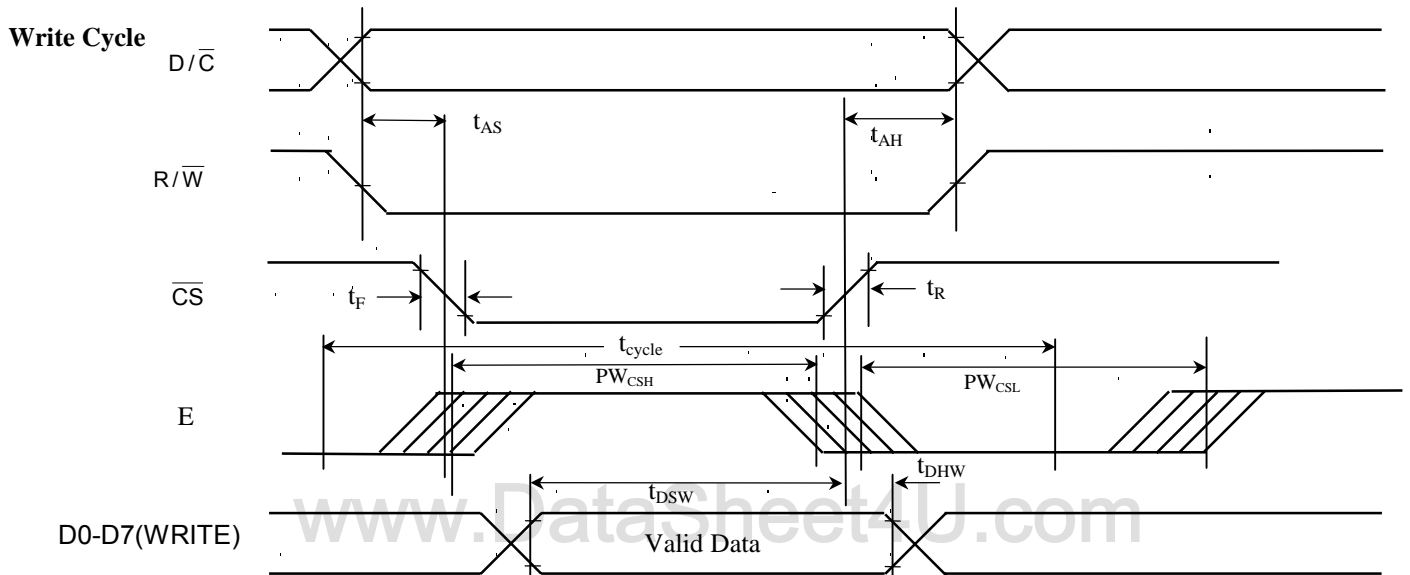

The PW_{CSH} timing reference is 50% of the rising / falling edge of E or \bar{CS} pin.

The t_{DSW} and t_{DHW} timing is reference to the 50% of rising / falling edge of E or \bar{CS} pin.

**Figure 21 – Parallel 6800-series Interface Timing Characteristics** ($PS0 = H$, $PS1 = H$)

Table 18 – Parallel 8080-series Interface Timing Characteristics ($T_A = -40$ to 85°C , $V_{DD} = 2.4\text{V}$, $V_{DDIO} = 1.2\text{V}$ to V_{DD})

Symbol	Parameter	Min	Typ	Max	Unit
t_{cycle}	Clock Cycle Time (write cycle)	250	-	-	ns
PW_{CSL}	Control Pulse Low Width	125	-	-	ns
PW_{CSH}	Control Pulse High Width	125	-	-	ns
t_{AS}	Address Setup Time	15	-	-	ns
t_{AH}	Address Hold Time	10	-	-	ns
t_{DSW}	Data Setup Time	10	-	-	ns
t_{DHW}	Data Hold Time	20	-	-	ns
t_{ACC}	Data Access Time	15	-	170	ns
t_{OH}	Output Hold time	20	-	60	ns

Write Cycle

The PW_{CSL} timing reference is 50% of the rising / falling edge of \overline{WR} or \overline{CS} pin.

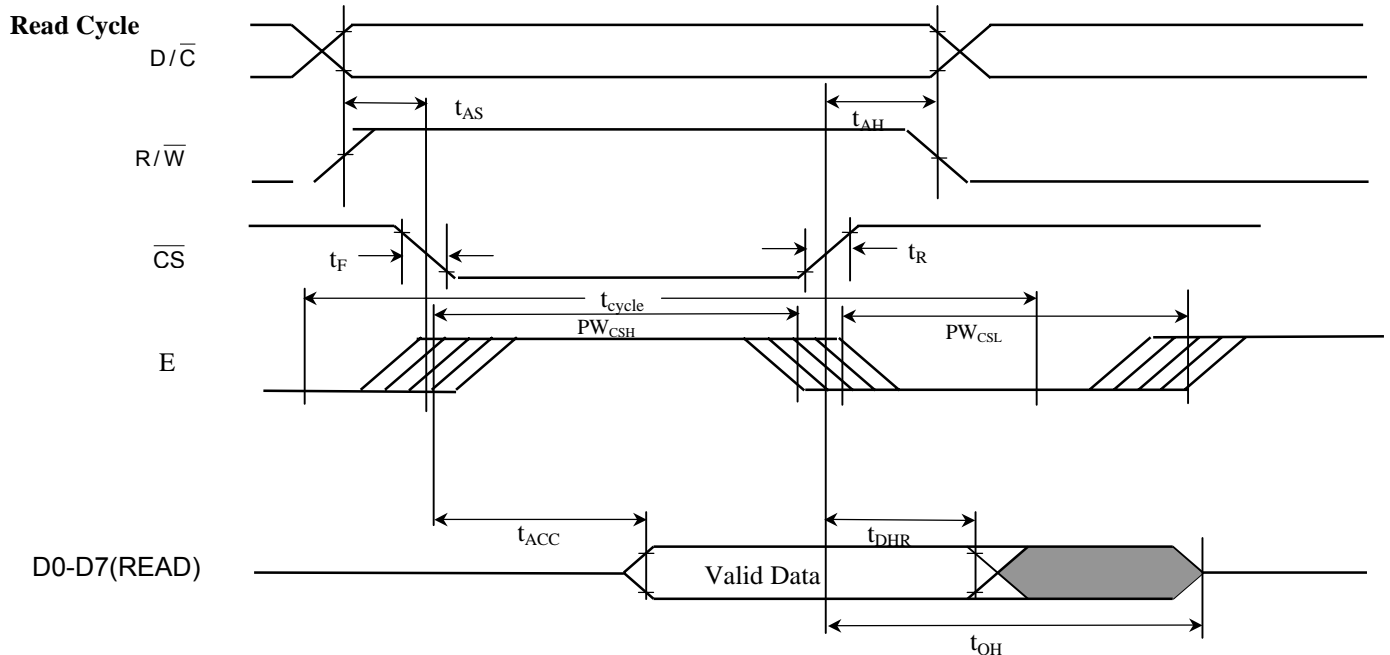
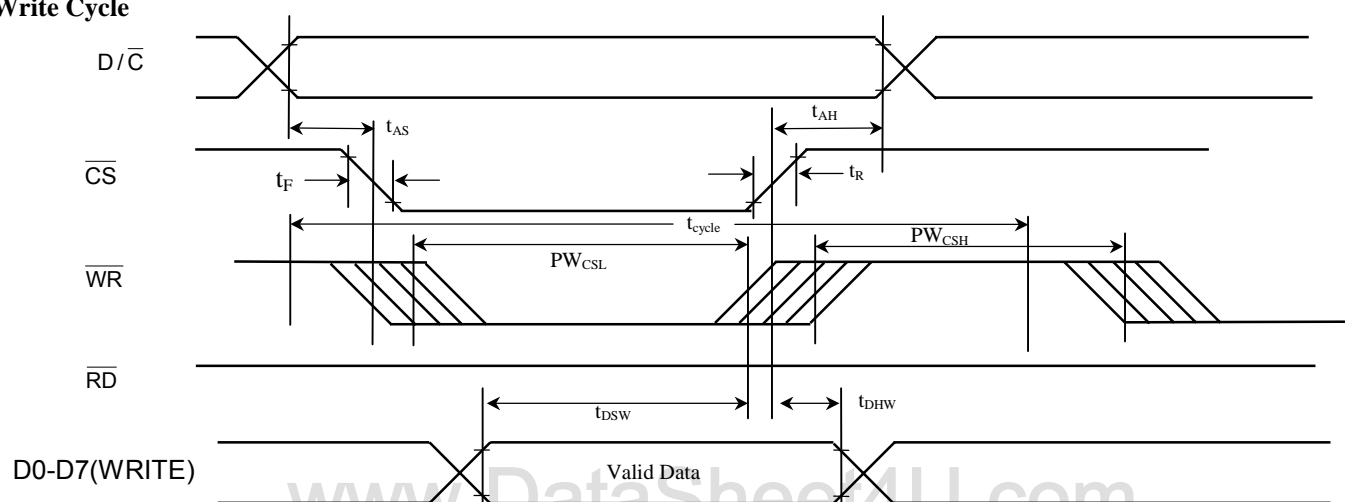
The t_{DSW} and t_{DHW} timing is reference to the 50% of rising / falling edge of \overline{WR} or \overline{CS} pin.

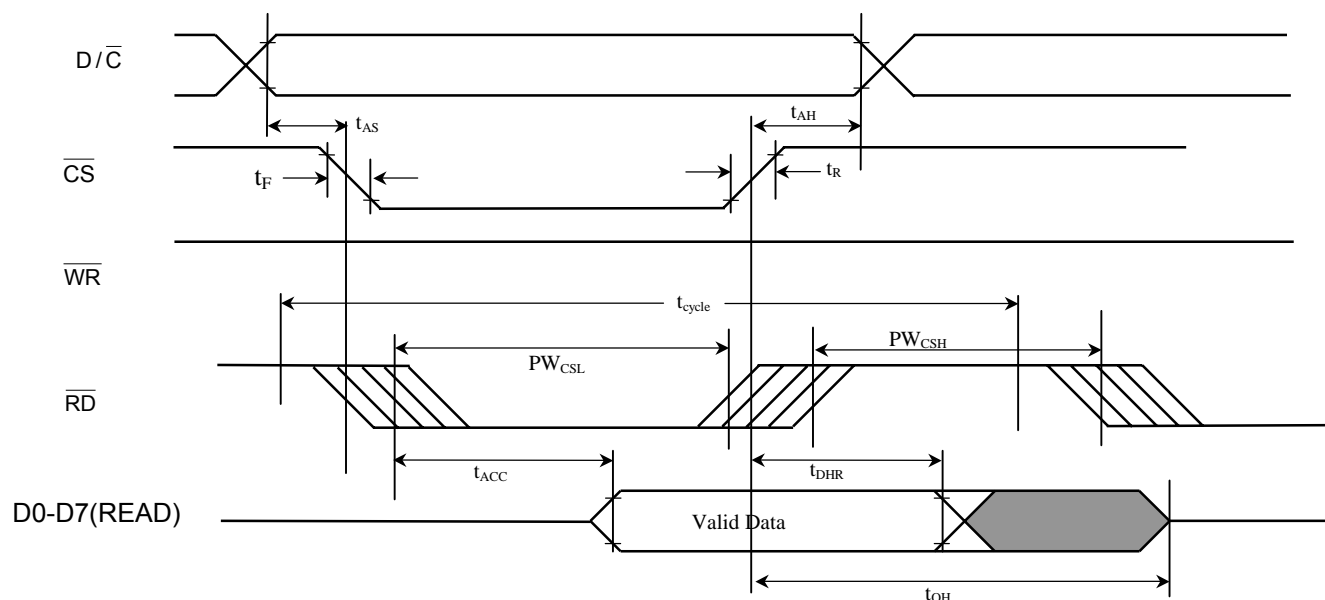
Read Cycle

The PW_{CSL} timing reference is 50% of the rising / falling edge of \overline{RD} or \overline{CS} pin.

The t_{DSW} and t_{DHW} timing is reference to the 50% of rising / falling edge of \overline{RD} or \overline{CS} pin.

Figure 22 – Parallel 8080-series Interface Timing Characteristics (PS0 = H, PS1 = L)

Table 19 – 4-Wires Serial Timing Characteristics ($T_A = -40$ to 85°C , $V_{DD} = 2.6\text{V}$ to 3.6V , $V_{DDIO} = 1.2\text{V}$ to V_{DD})

Symbol	Parameter	Min	Typ	Max	Unit
t_{cycle}	Clock Cycle Time	50	-	-	ns
f_{CLK}	Serial Clock Cycle Time SPI Clock tolerance = +/- 2 ppm	-	-	20	MHz
t_{AS}	Register select Setup Time	90	-	-	ns
t_{AH}	Register select Hold Time	20	-	-	ns
t_{CSS}	Chip Select Setup Time	10	-	-	ns
t_{CSH}	Chip Select Hold Time	30	-	-	ns
t_{DSW}	Write Data Setup Time	10	-	-	ns
t_{DHW}	Write Data Hold Time	10	-	-	ns
t_{CLKL}	Clock Low Time	15	-	-	ns
t_{CLKH}	Clock High Time	15	-	-	ns

**Figure 23 – 4-Wires Serial Timing Characteristics** ($PS0 = L$, $PS1 = L$)

Table 20 – 3-Wires Serial Timing Characteristics ($T_A = -40$ to 85°C , $V_{DD} = 2.6\text{V}$ to 3.6V , $V_{DDIO} = 1.2\text{V}$ to V_{DD})

Symbol	Parameter	Min	Typ	Max	Unit
t_{cycle}	Clock Cycle Time	50	-	-	ns
f_{CLK}	Serial Clock Cycle Time SPI Clock tolerance = +/- 2 ppm	-	-	20	MHz
t_{CSS}	Chip Select Setup Time	10	-	-	ns
t_{CSH}	Chip Select Hold Time	30	-	-	ns
t_{DSW}	Write Data Setup Time	10	-	-	ns
t_{OHW}	Write Data Hold Time	10	-	-	ns
t_{CLKL}	Clock Low Time	30	-	-	ns
t_{CLKH}	Clock High Time	30	-	-	ns

**Figure 24 – 3-Wires Serial Timing Characteristics (PS0 = L, PS1 =H)**

Table 21 – 4-Wires Serial Timing Characteristics ($T_A = -40$ to 85°C , $V_{DD} = 2.4\text{V}$, $V_{DDIO} = 1.2\text{V}$ to V_{DD})

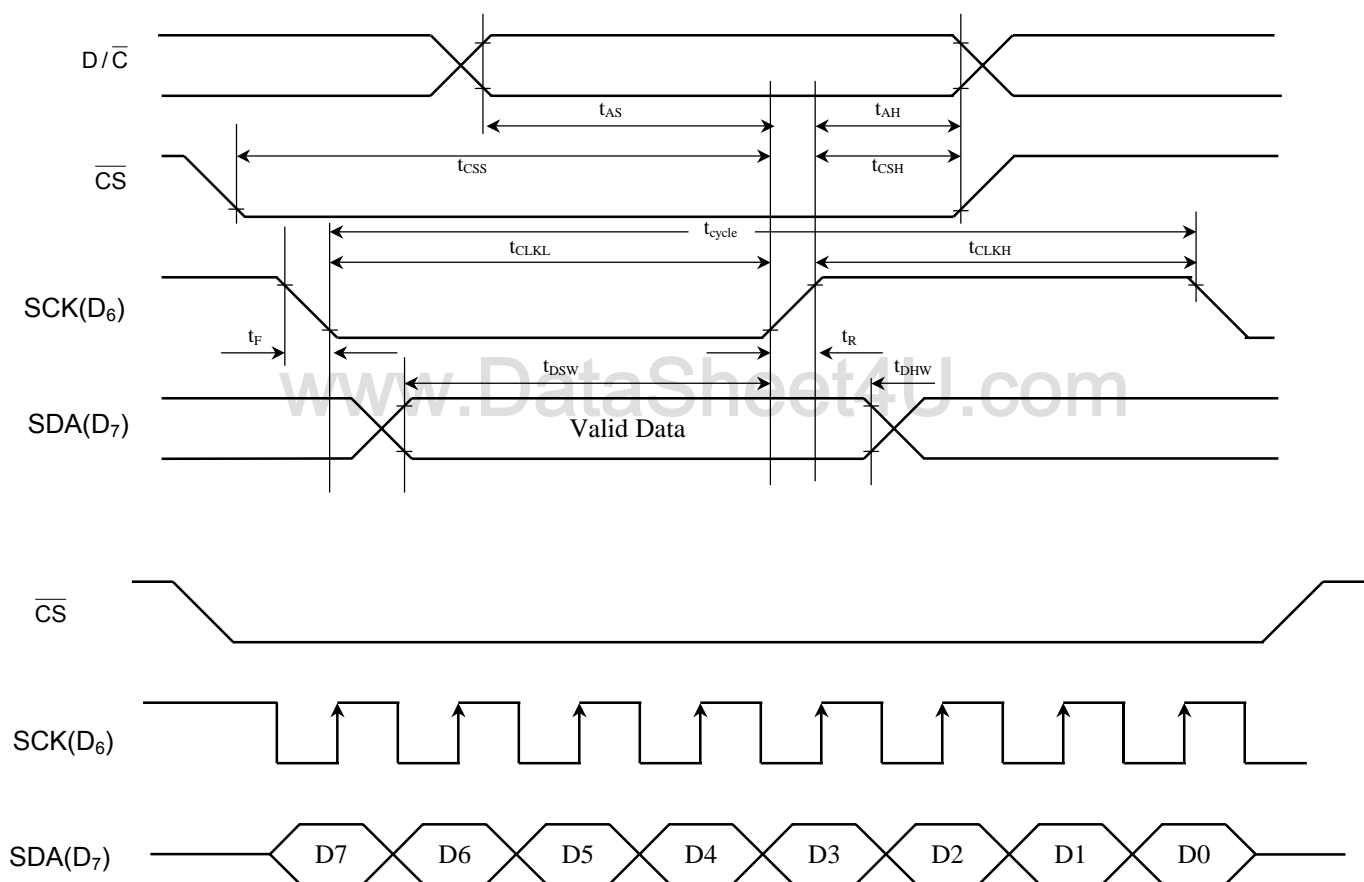
Symbol	Parameter	Min	Typ	Max	Unit																		
t_{cycle}	Clock Cycle Time	60	-	-	ns																		
f_{CLK}	Serial Clock Cycle Time SPI Clock tolerance = +/- 2 ppm	-	-	16.6	MHz																		
t_{AS}	Register select Setup Time	90	-	-	ns																		
t_{AH}	Register select Hold Time	20	-	-	ns																		
t_{CSS}	Chip Select Setup Time	10	-	-	ns																		
t_{CSH}	Chip Select Hold Time	30	-	-	ns																		
t_{DSW}	Write Data Setup Time	10	-	-	ns </tr <tr> <td>t_{DHW}</td> <td>Write Data Hold Time</td> <td>10</td> <td>-</td> <td>-</td> <td>ns</td> </tr> <tr> <td>t_{CLKL}</td> <td>Clock Low Time</td> <td>15</td> <td>-</td> <td>-</td> <td>ns</td> </tr> <tr> <td>t_{CLKH}</td> <td>Clock High Time</td> <td>15</td> <td>-</td> <td>-</td> <td>ns</td> </tr>	t_{DHW}	Write Data Hold Time	10	-	-	ns	t_{CLKL}	Clock Low Time	15	-	-	ns	t_{CLKH}	Clock High Time	15	-	-	ns
t_{DHW}	Write Data Hold Time	10	-	-	ns																		
t_{CLKL}	Clock Low Time	15	-	-	ns																		
t_{CLKH}	Clock High Time	15	-	-	ns																		

**Figure 25 – 4-Wires Serial Timing Characteristics** ($PS0 = L$, $PS1 = L$)

Table 22 – 3-Wires Serial Timing Characteristics ($T_A = -40$ to 85°C , $V_{DD} = 2.4\text{V}$, $V_{DDIO} = 1.2\text{V}$ to V_{DD})

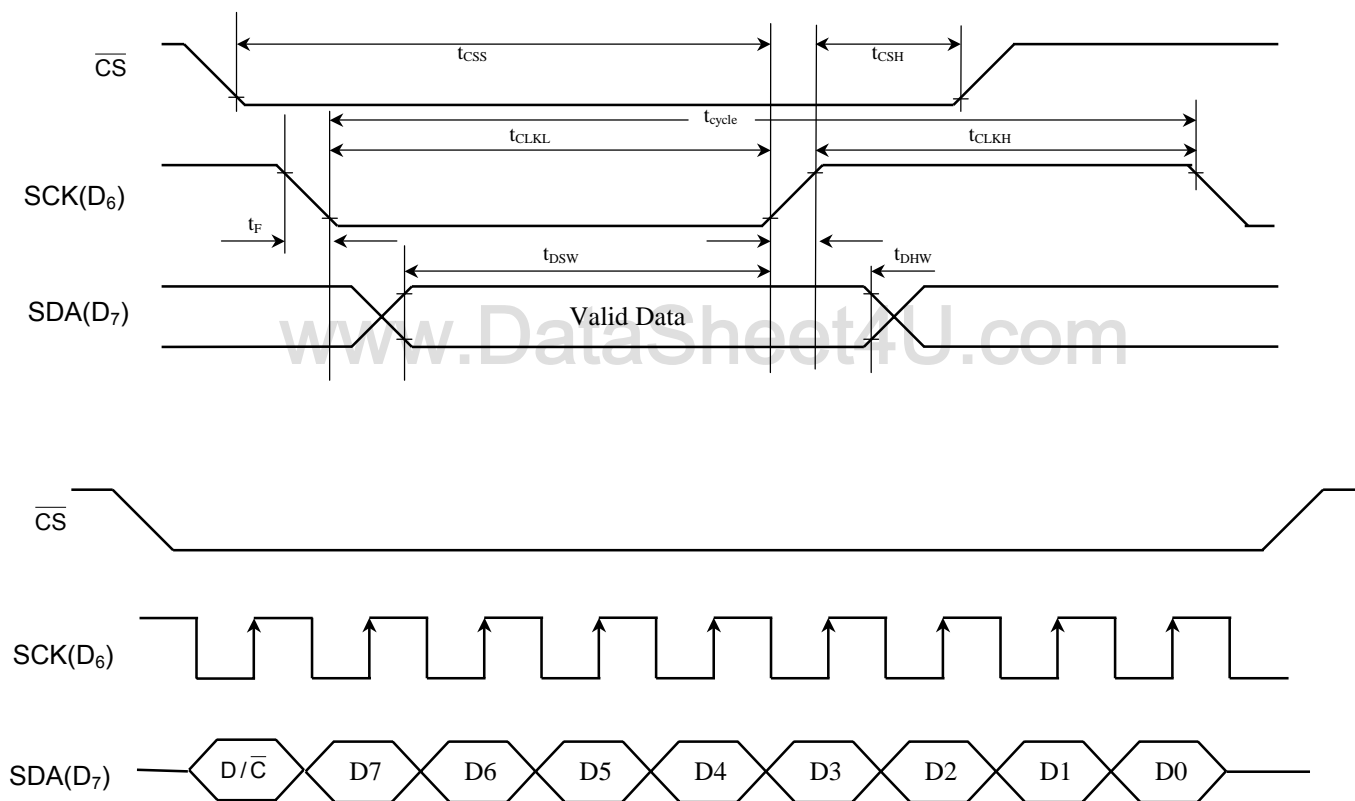
Symbol	Parameter	Min	Typ	Max	Unit
t_{cycle}	Clock Cycle Time	60	-	-	ns
f_{CLK}	Serial Clock Cycle Time SPI Clock tolerance = +/- 2 ppm	-	-	16.6	MHz
t_{CSS}	Chip Select Setup Time	10	-	-	ns
t_{CSH}	Chip Select Hold Time	30	-	-	ns
t_{DSW}	Write Data Setup Time	10	-	-	ns
t_{OHW}	Write Data Hold Time	10	-	-	ns
t_{CLKL}	Clock Low Time	30	-	-	ns
t_{CLKH}	Clock High Time	30	-	-	ns

**Figure 26 – 3- Wires Serial Timing Characteristics** (PS0 = L, PS1 =H)

Table 23 – Power Up/Down Timing Characteristics ($T_A = -40$ to 85°C , $V_{DD} = 2.4\text{V}$ to 3.6V , $V_{DDIO} = 1.2\text{V}$ to V_{DD})

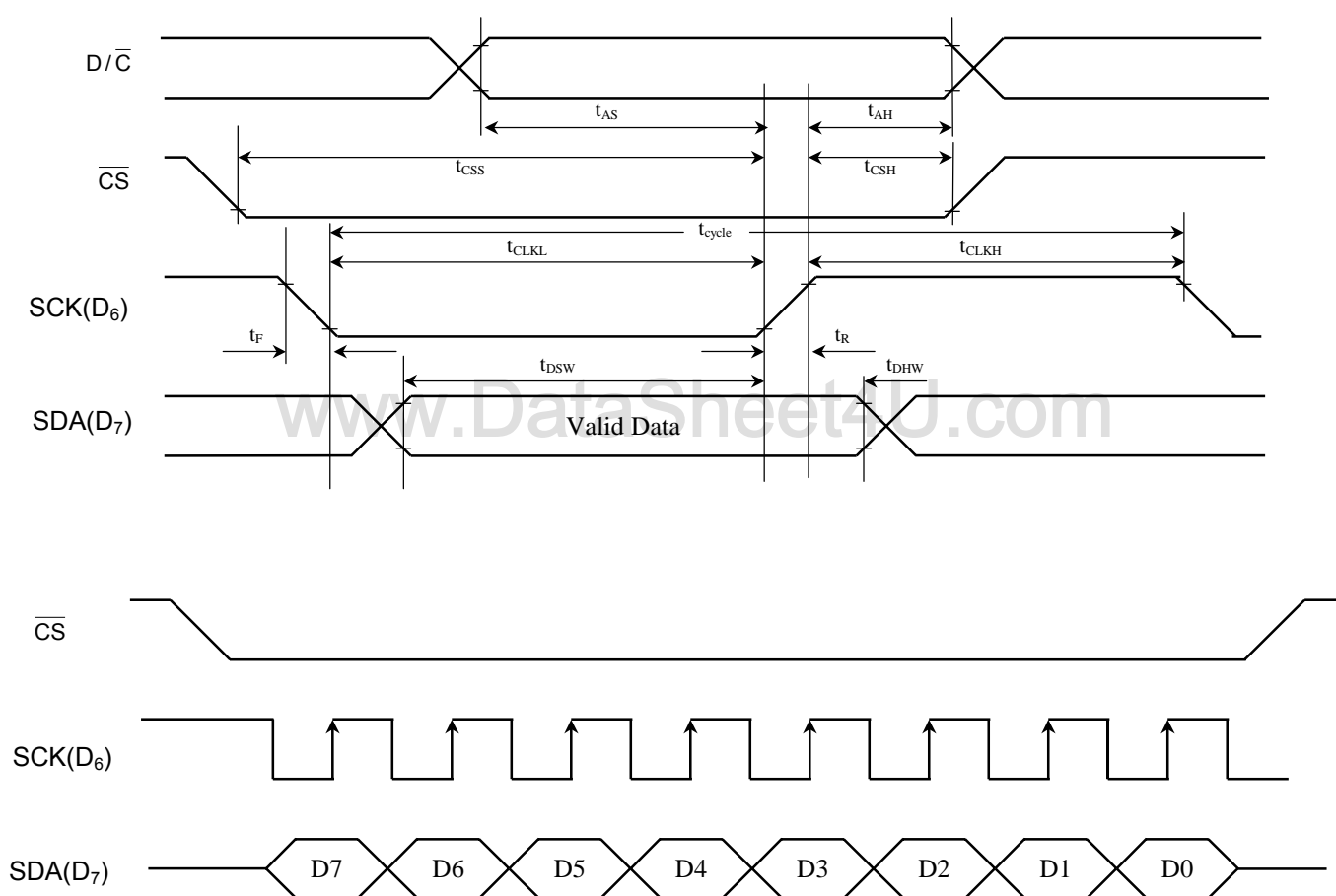
Symbol	Parameter	Min	Typ	Max	Unit
t_{PR}	Power rise time	-	-	30	μs
t_{PD}	Power delay time	-	-	30	μs
t_{STABLE}	Chip stable time	-	-	10	μs
t_{RES}	Reset pulse	10	-	-	μs
t_{READY}	Chip need time after hardware reset	-	-	1	μs

**Figure 27 – Power Up**

Symbol	Parameter	Min	Typ	Max	Unit
t_{CHARGE}	V_{OUT} Charge up wait time (charge up to 11.7V)	50	-	-	ms
t_{PDOWN}	Power Hold time	50	-	-	ms

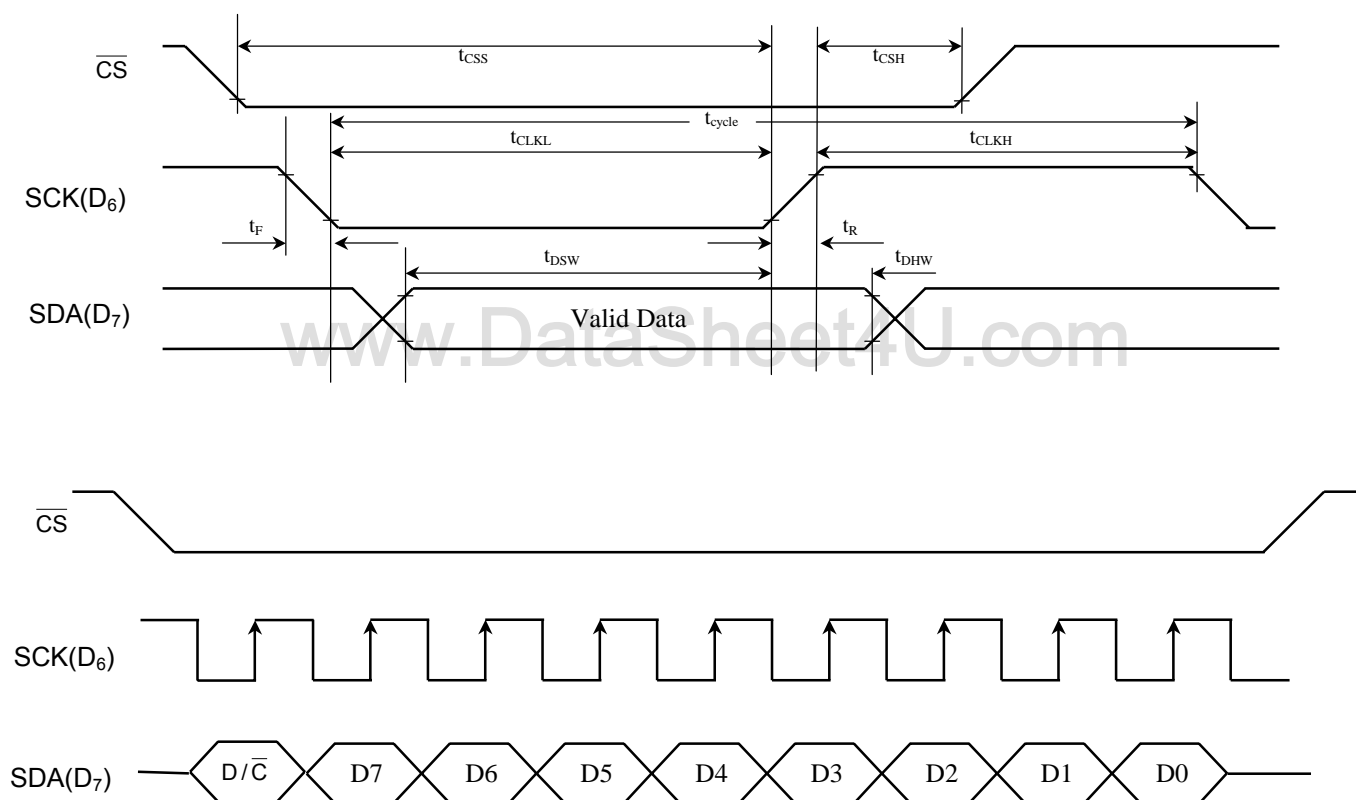
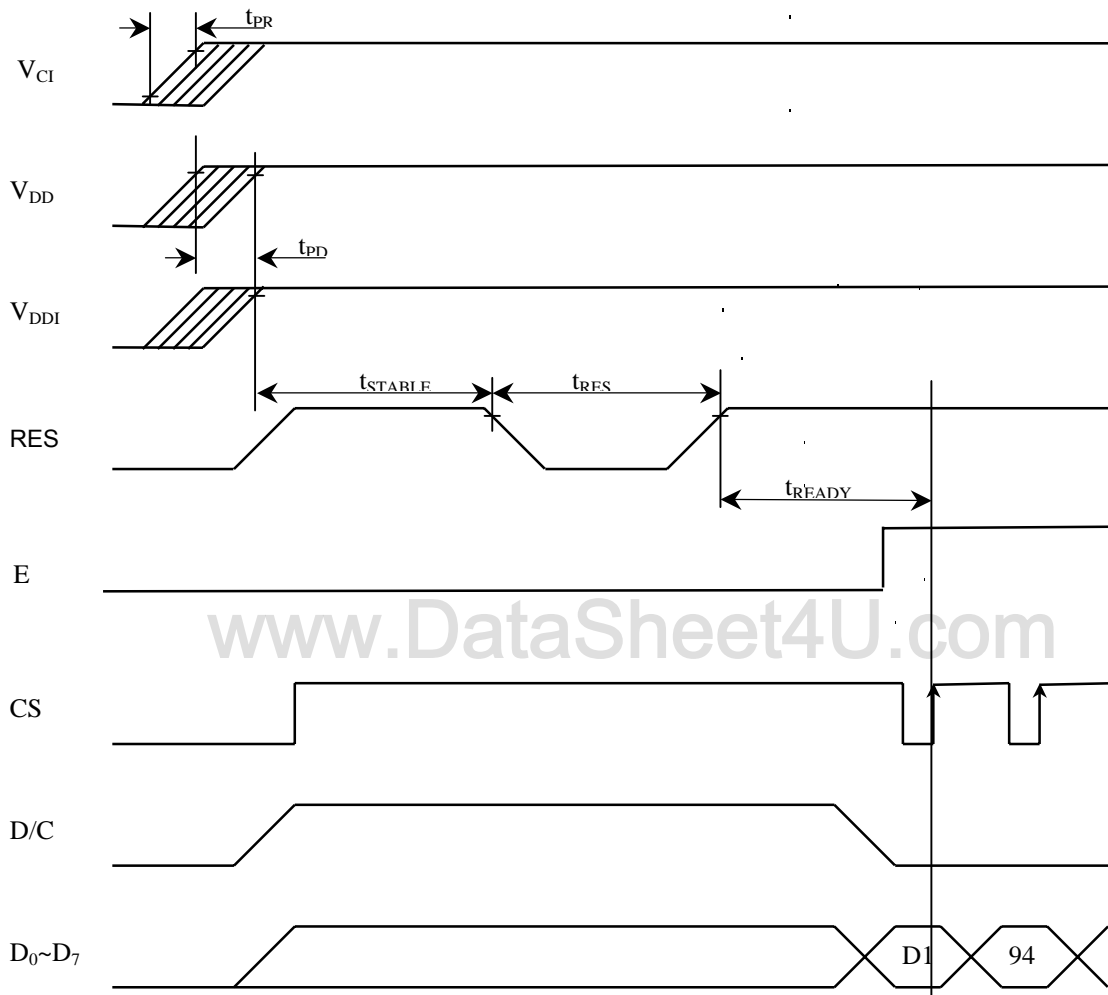
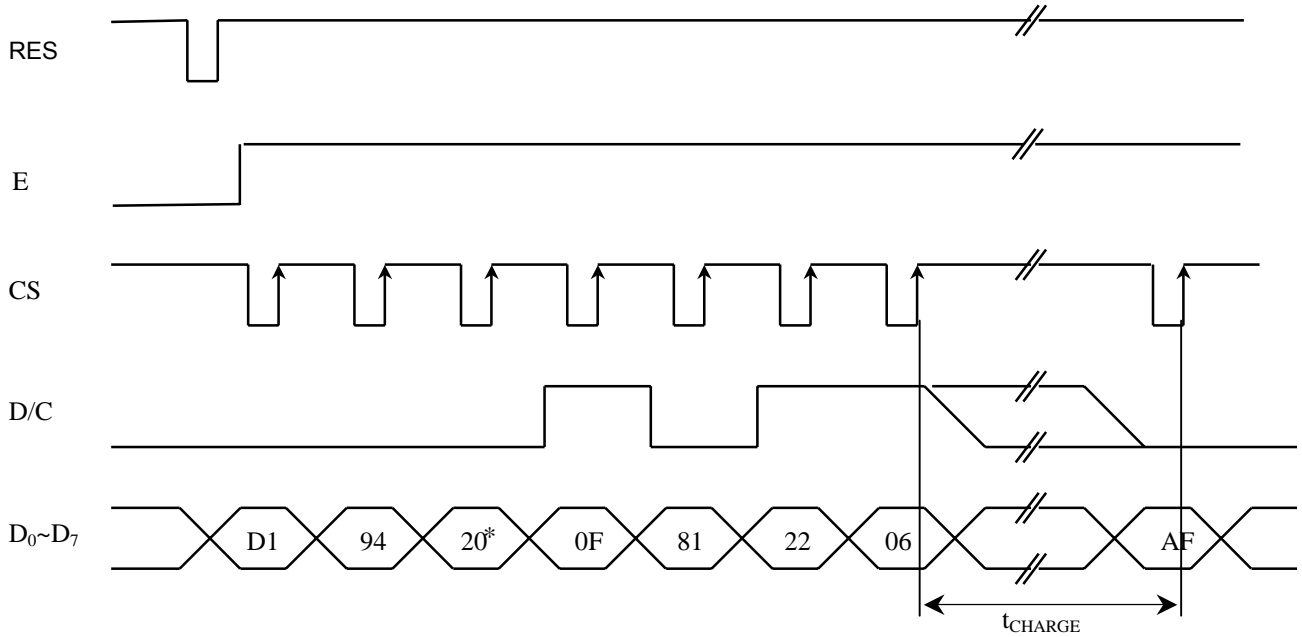
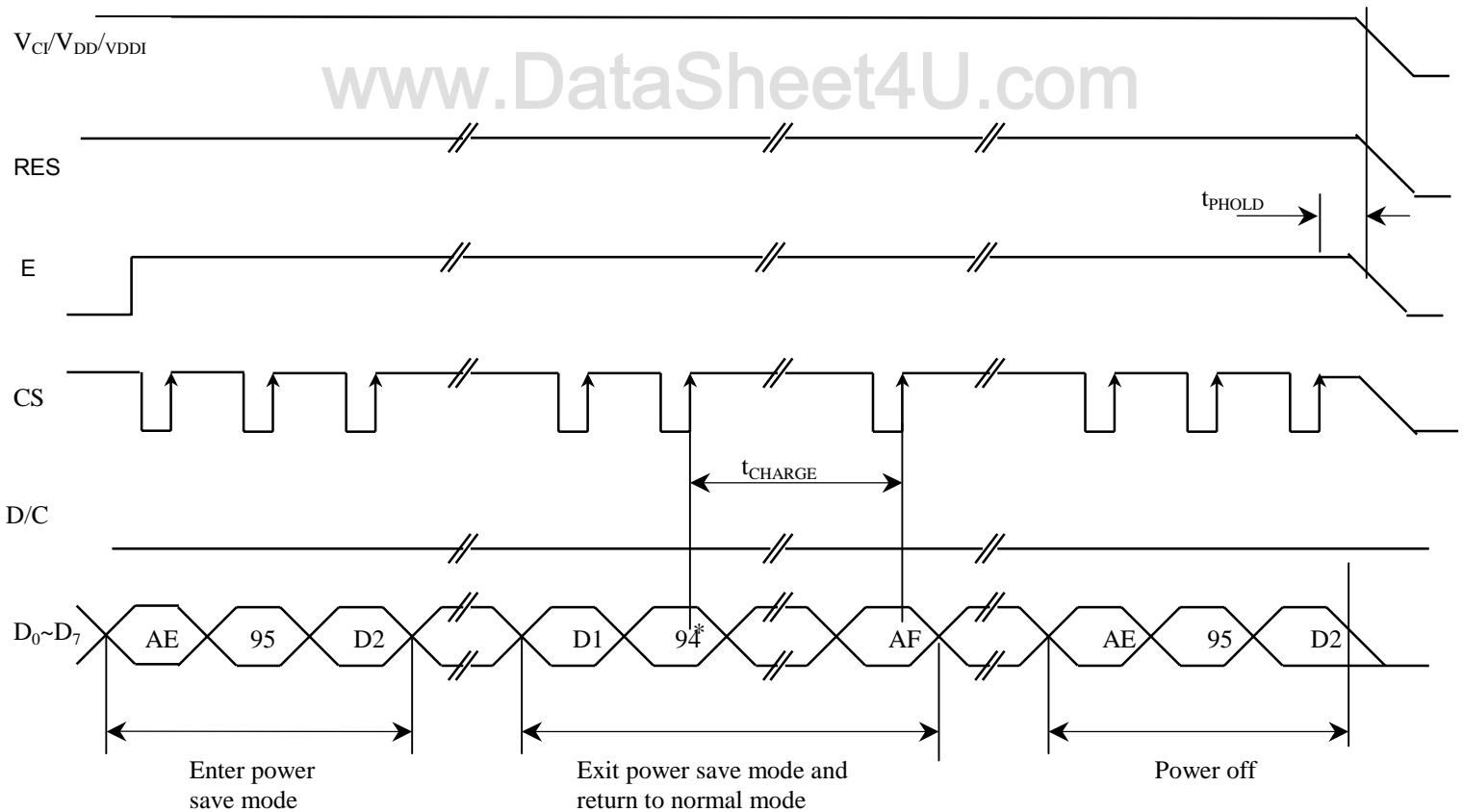

Figure 28 – Initial Code Timing Chart



- After enable Booster & Regulator circuitry, there has 200ms mask off period that is used to provide a wait time to charge up V_{OUT} capacitor. Within the mask off period, SEG doesn't have output waveform.

Figure 29 – Power save / power up / power off timing chart

13 APPLICATION EXAMPLES

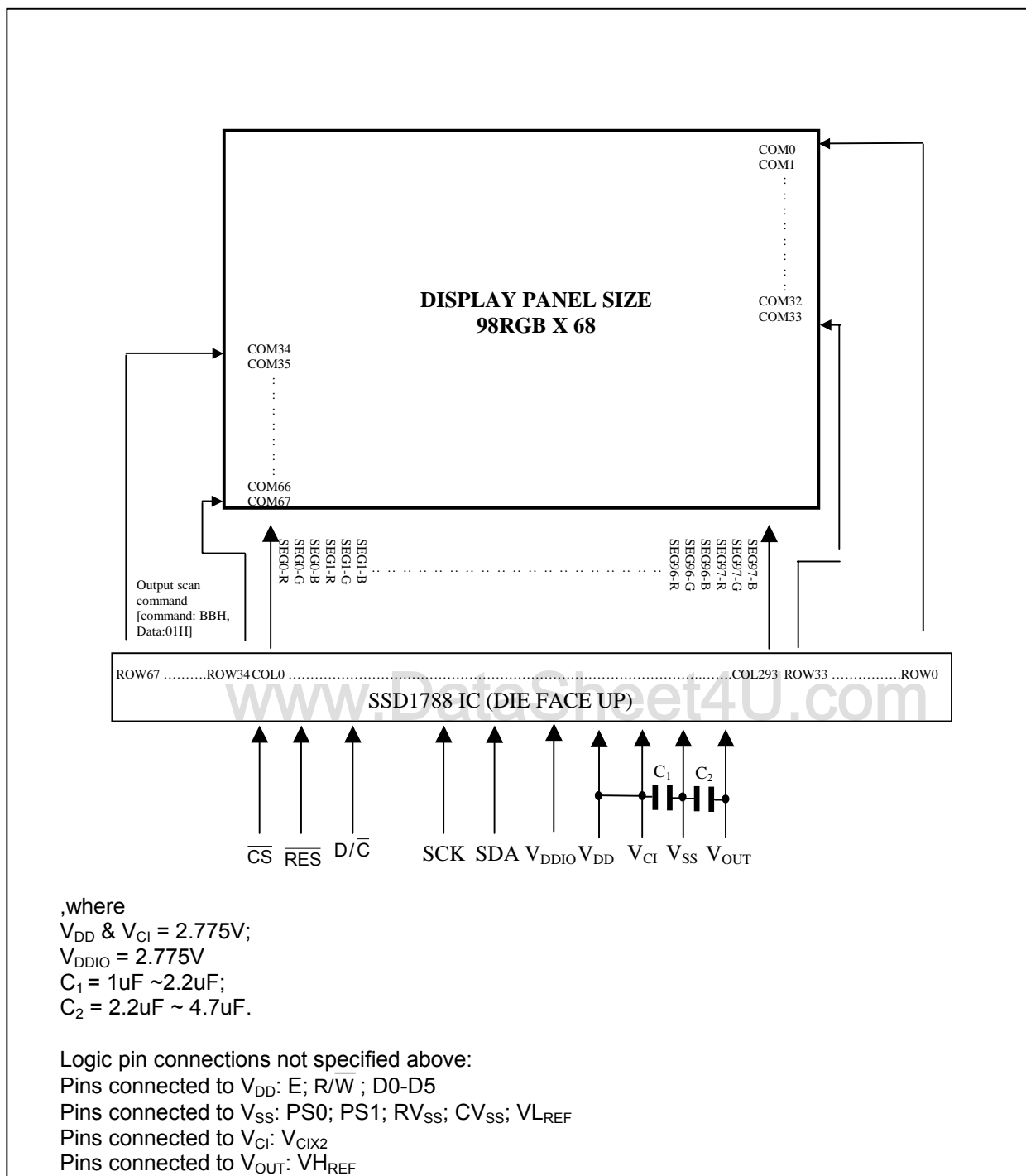

Figure 30 - Application Examples I (4-wires SPI mode)

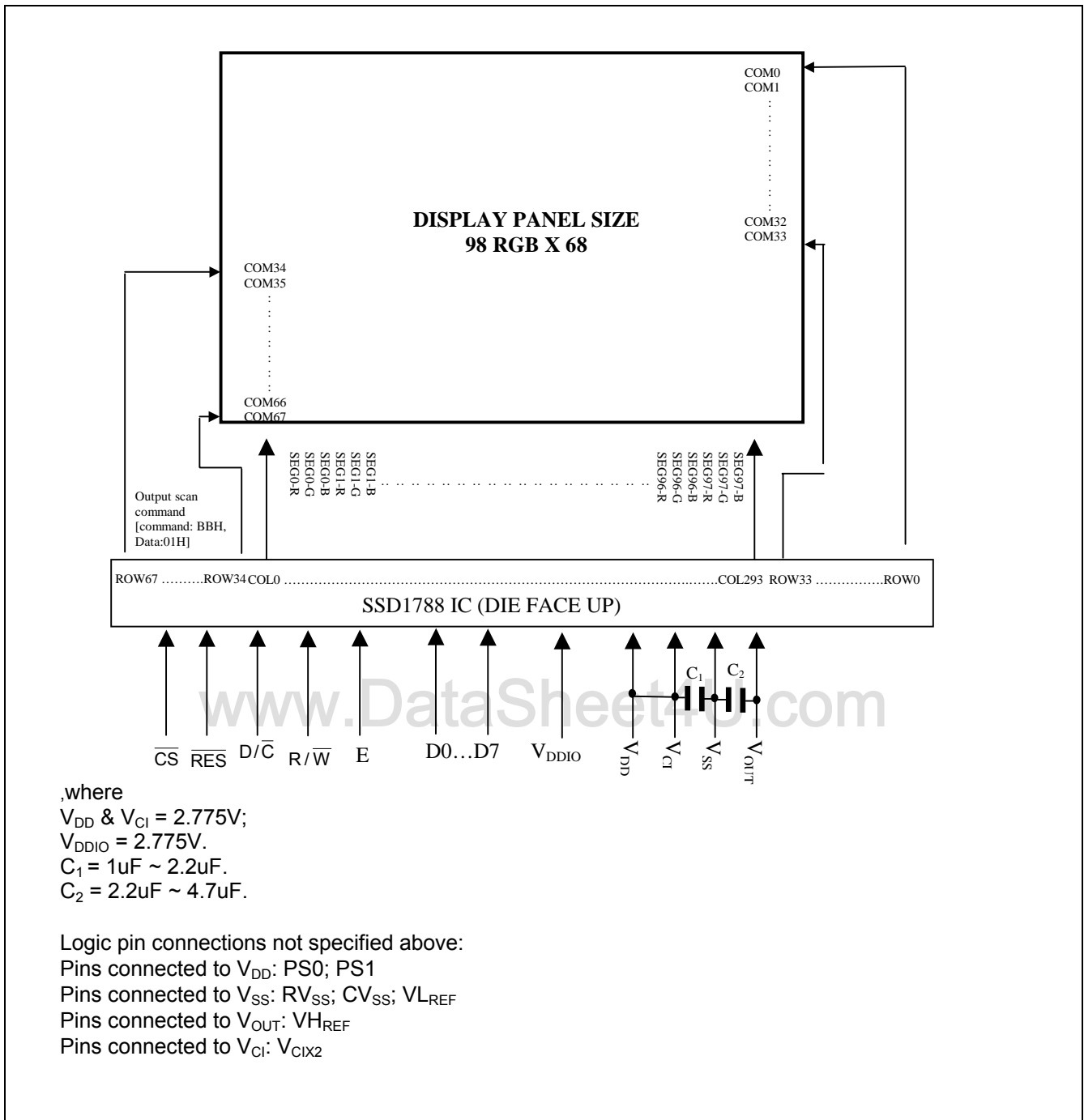

Figure 31 - Application Examples II (6800 PPI mode)

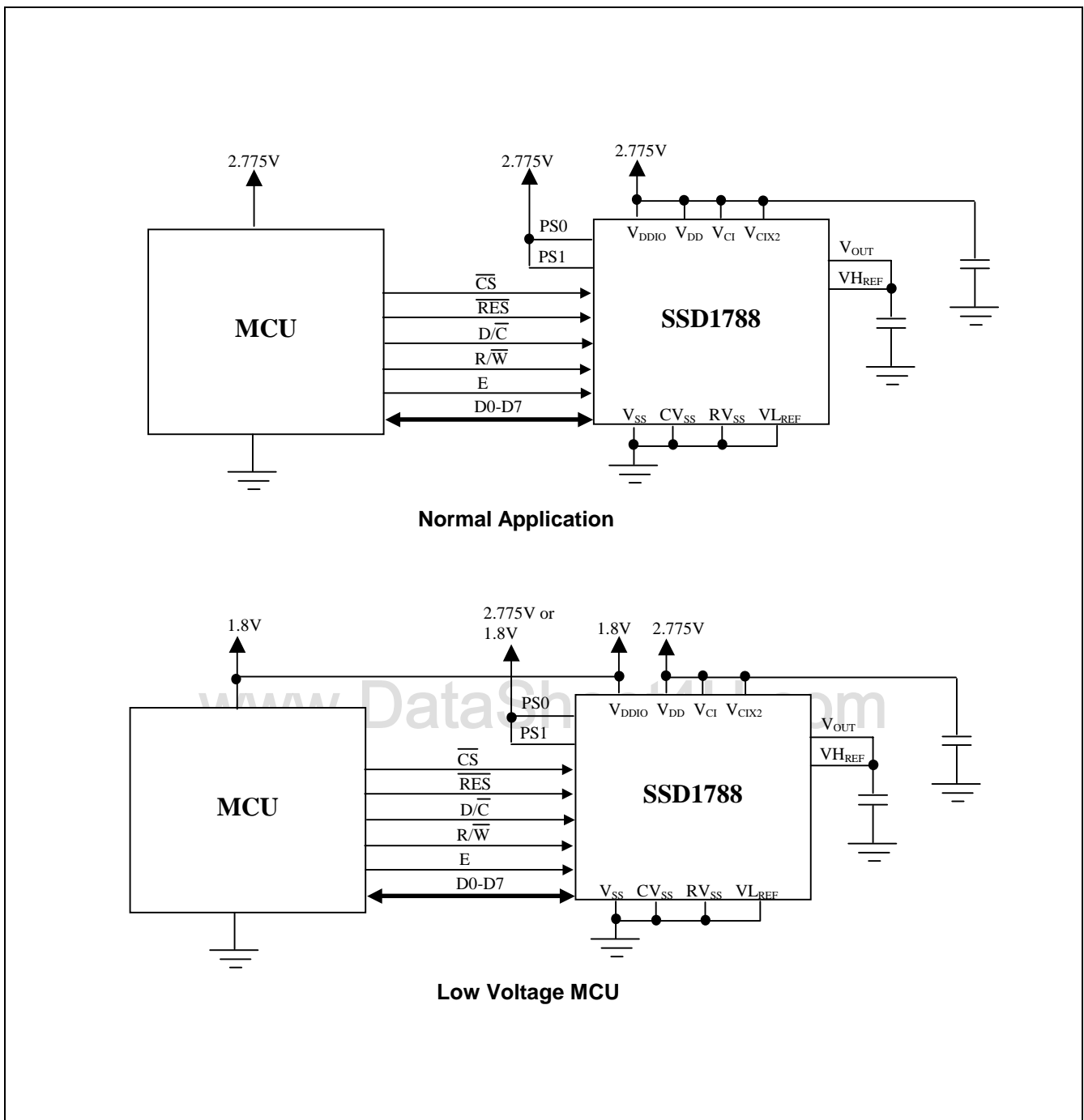
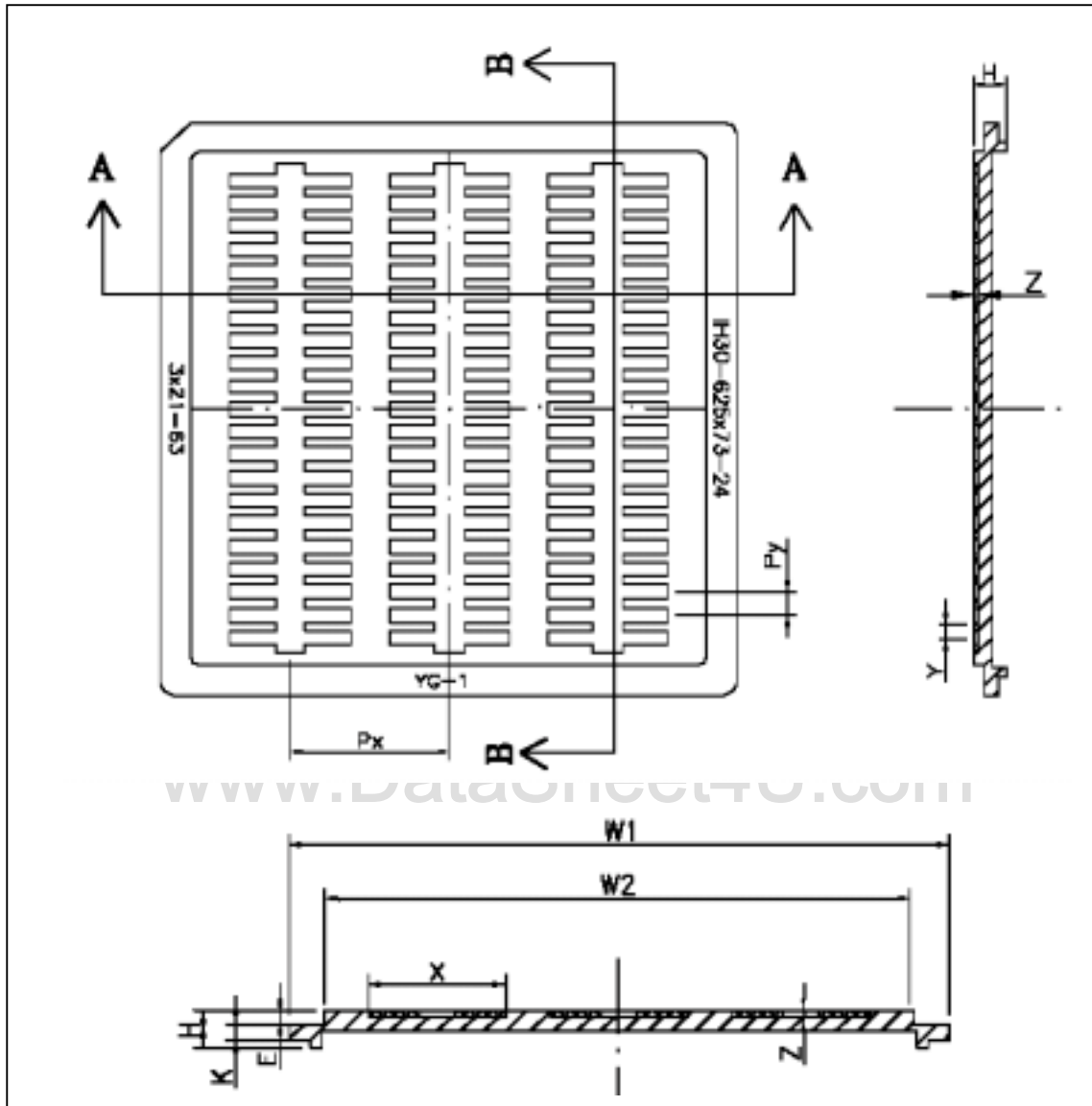

Figure 32 – Applications notes for V_{DD}/V_{DDIO} connection

14 PACKAGE INFORMATION

14.1 DIE TRAY DIMENSIONS



Spec	mm	(mil)
W1	76.0 ^{+0.2} _{-0.1}	(2992)
W2	68.0 ^{+0.2} _{-0.1}	(2677)
H	4.20 ± 0.1	(165)
E	1.60 ± 0.1	(63)
K	1.90 ± 0.1	(75)
Px	20.79 ± 0.1	(826)
Py	3.03 ± 0.1	(119)
X	15.88 ^{+0.1} ₋₀	(625)
Y	1.85 ^{+0.1} ₋₀	(73)
Z	0.62 ± 0.05	(24)
N	63	

www.DataSheet4U.com

Solomon Systech reserves the right to make changes without further notice to any products herein. Solomon Systech makes no warranty, representation or guarantee regarding the suitability of its products for any particular purpose, nor does Solomon Systech assume any liability arising out of the application or use of any product or circuit, and specifically disclaims any and all liability, including without limitation consequential or incidental damages. "Typical" parameters can and do vary in different applications. All operating parameters, including "Typicals" must be validated for each customer application by customer's technical experts. Solomon Systech does not convey any license under its patent rights nor the rights of others. Solomon Systech products are not designed, intended, or authorized for use as components in systems intended for surgical implant into the body, or other applications intended to support or sustain life, or for any other application in which the failure of the Solomon Systech product could create a situation where personal injury or death may occur. Should Buyer purchase or use Solomon Systech products for any such unintended or unauthorized application, Buyer shall indemnify and hold Solomon Systech and its offices, employees, subsidiaries, affiliates, and distributors harmless against all claims, costs, damages, and expenses, and reasonable attorney fees arising out of, directly or indirectly, any claim of personal injury or death associated with such unintended or unauthorized use, even if such claim alleges that Solomon Systech was negligent regarding the design or manufacture of the part

<http://www.solomon-systech.com>